

QUESTIONS**QUESTION (2015:1)**

(d) Ethene gas, $C_2H_4(g)$, reacts with bromine gas, $Br_2(g)$, as shown in the equation below.

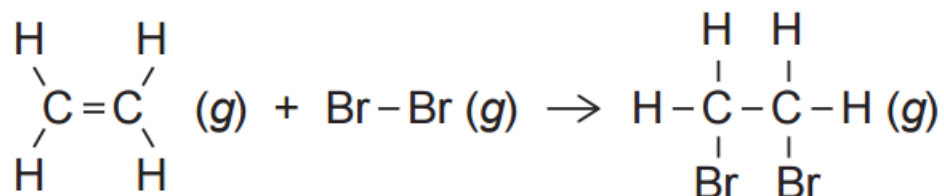

Calculate the enthalpy change, $\Delta_r H^\circ$, for the reaction between ethene and bromine gases, given the average bond enthalpies in the table below. Show your working and include appropriate units in your answer.

Bond	Average bond enthalpy/ kJ mol^{-1}
Br-Br	193
C-C	346
C=C	614
C-Br	285
C-H	414

QUESTION (2015:2)

(a) Hand warmers contain a supersaturated solution of sodium ethanoate which, when activated, crystallises and releases heat. Circle the term that best describes this reaction.

exothermic endothermic

Give a reason for your choice.

(b) (i) Glucose is made in plants during photosynthesis when carbon dioxide gas, $CO_2(g)$, and water, $H_2O(l)$, react to produce glucose, $C_6H_{12}O_6(aq)$, and oxygen gas, $O_2(g)$. The photosynthesis reaction can be represented by the following equation: $6CO_2(g) + 6H_2O(l) \rightarrow C_6H_{12}O_6(aq) + 6O_2(g)$ $\Delta_r H^\circ = 2803 \text{ kJ mol}^{-1}$

Circle the term that best describes this reaction.

exothermic endothermic

Give a reason for your choice.

(ii) Calculate how much energy is absorbed or released in the photosynthesis reaction if 19.8 g of carbon dioxide gas, $CO_2(g)$, reacts completely with excess water, $H_2O(l)$, to form glucose, $C_6H_{12}O_6(aq)$, and oxygen gas, $O_2(g)$. Show your working and include appropriate units in your answer. $M(CO_2) = 44.0 \text{ g mol}^{-1}$.

● CHEMISTRY

- (c) A small camp stove containing butane gas, $C_4H_{10}(g)$, is used to heat some water, as shown in the diagram below. A student measures the temperature change in the water and calculates that when 3.65 g of butane is combusted, 106 kJ of heat is released.

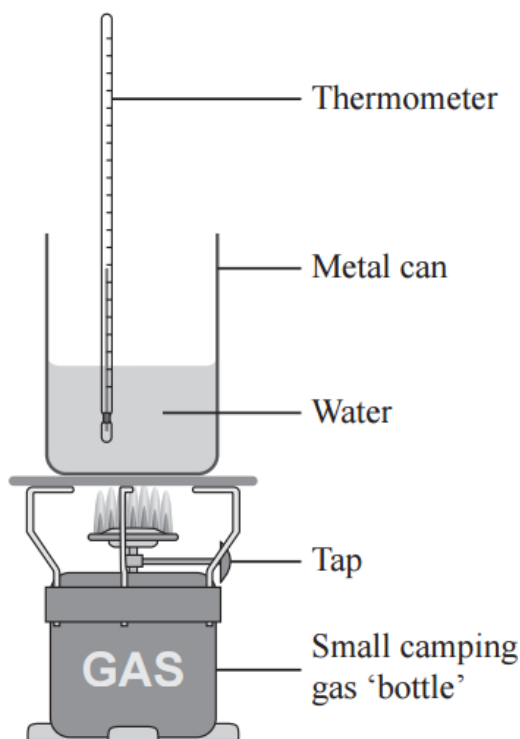

The reaction for the combustion of butane is shown in the equation below.

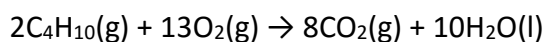

- Calculate the enthalpy change ($\Delta_r H$) for this reaction, based on the above measurements. $M(C_4H_{10}) = 58.0 \text{ g mol}^{-1}$.
- The accepted enthalpy change for the combustion reaction of butane gas, $C_4H_{10}(g)$, is $\Delta_r H = -5754 \text{ kJ mol}^{-1}$. Explain why the result you calculated in part (c)(i) is different to the accepted value. In your answer, you should include at least TWO reasons.
- Complete, including labels, the energy diagram for the combustion of butane gas showing reactants, products, and the change in enthalpy.

● CHEMISTRY

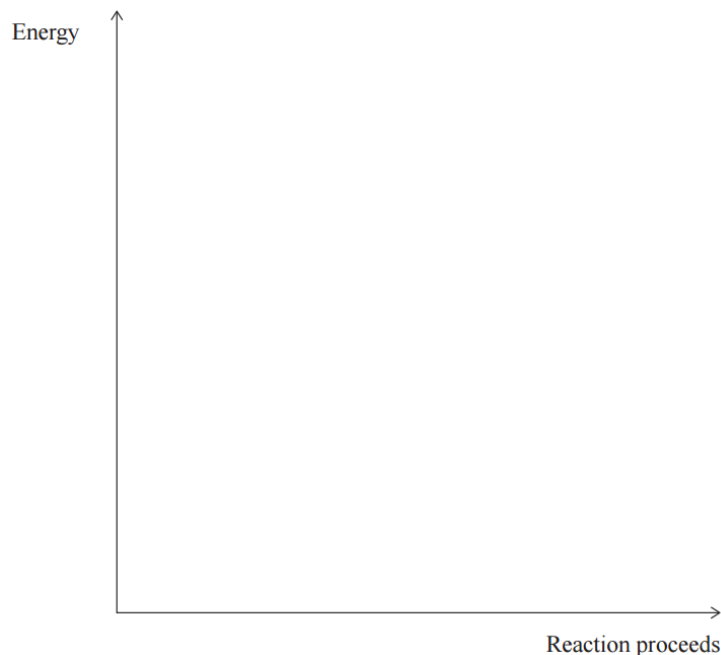

- (iv) Butane gas is a useful fuel because when it undergoes combustion, energy is released. Explain why energy is released in this reaction, in terms of making and breaking bonds. No calculations are required

QUESTION (2014:1)

- (d) Hydrogen gas, $\text{H}_2(g)$, reacts with oxygen gas, $\text{O}_2(g)$, as shown by the following equation

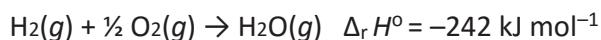

Given the average bond enthalpies in the table below, calculate the average bond enthalpy of the O – H bond in H_2O .

Bond	Average bond enthalpy / kJ mol^{-1}
H – H	436
O = O	498

QUESTION (2014:3)

- (a) (i) When solid sodium hydroxide is added to water, the temperature increases. Circle the term that best describes this reaction.

Exothermic Endothermic

Give a reason for your choice.

- (ii) The freezing of water to form ice can be represented by the following equation.

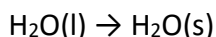

Circle the term that best describes this reaction.

Exothermic Endothermic

Explain your choice.

- (c) Methanol and ethanol can both be used as fuels. Their combustion reactions can be represented by the following equations:

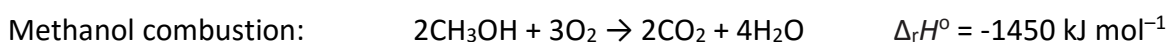

● CHEMISTRY

Ethanol combustion: $\text{C}_2\text{H}_5\text{OH} + 3\text{O}_2 \rightarrow 2\text{CO}_2 + 3\text{H}_2\text{O}$ $\Delta_r H^\circ = -1370 \text{ kJ mol}^{-1}$

Justify which fuel, methanol or ethanol, will produce more heat energy when 345 g of each fuel is combusted in excess oxygen.

$$M(\text{CH}_3\text{OH}) = 32.0 \text{ g mol}^{-1}$$

$$M(\text{C}_2\text{H}_5\text{OH}) = 46.0 \text{ g mol}^{-1}$$

QUESTION (2013:2)

- (c) Chlorine reacts with methane to form chloromethane and hydrogen chloride, as shown in the equation below.

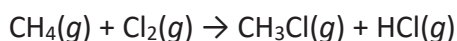

Use the following bond enthalpies to calculate $\Delta_r H^\circ$ for this reaction.

Bond	Bond enthalpy / kJ mol^{-1}
H – Cl	431
C – H	414
C – Cl	324
Cl – Cl	242

QUESTION (2013:3)

- (a) Dissolving ammonium nitrate in a beaker containing water can be represented by the following equation:

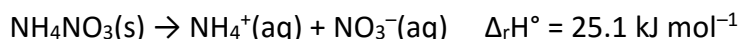

Circle the term below that best describes this process.

exothermic endothermic

Circle the description below that best describes what you would observe happening to the beaker during this process.

gets colder stays the same gets warmer

Explain your choices.

- (b) Glucose is an important source of energy in our diet. The equation below shows the combustion of glucose to form carbon dioxide and water.

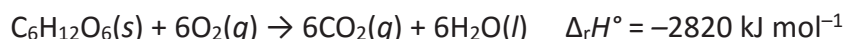

- (i) Circle the term below that best describes this process.

exothermic endothermic

Give a reason for your choice.

- (ii) Females who are moderately active need 9 800 kJ of energy per day.

Calculate the number of moles of glucose that would provide this daily energy requirement.

● CHEMISTRY

- (c) (i) Many portable BBQ and camping gas canisters contain butane, C_4H_{10} . Butane is a gas at room temperature, and has a boiling point of $-0.5^\circ C$. The gas canisters contain both gas and liquid butane. As the gaseous butane is used, some of the liquid evaporates.

Circle the term below that best describes this process.

exothermic endothermic

Give a reason for your choice, and use your knowledge of structure and bonding, and energy changes, to explain the changes occurring as the liquid evaporates.

- (ii) The equation below shows the combustion of butane.

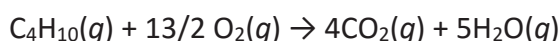

When 100 g of butane undergoes combustion, 4960 kJ of energy is released.

Calculate the enthalpy change when 1 mole of butane undergoes combustion.

$$M(C_4H_{10}) = 58.1 \text{ g mol}^{-1}.$$

- (d) The iron oxides Fe_3O_4 and Fe_2O_3 react with aluminium as shown below.

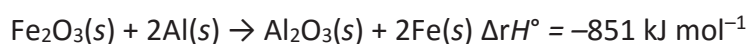
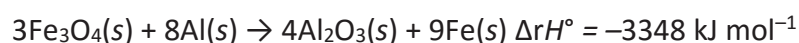

Justify which iron oxide, Fe_3O_4 or Fe_2O_3 , will produce more heat energy when 2.00 kg of iron is formed during the reaction with aluminium.

Your answer should include calculations of the heat energy produced for the given mass of iron formed. $M(Fe) = 55.9 \text{ g mol}^{-1}$.

QUESTION (2012:3)

- (a) Some Bunsen burners use methane gas, CH_4 , as a fuel. The reaction for the combustion of methane in a Bunsen burner is shown in Equation One below.

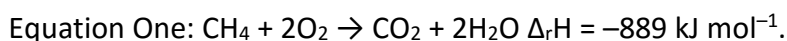

When this reaction occurs, bonds are broken and bonds are formed.

State which bonds are broken and which bonds are formed during the reaction.

Bonds broken:

Bonds formed:

- (b) Calculate the energy released when 128 g of methane is burnt.

$$M(CH_4) = 16.0 \text{ g mol}^{-1}.$$

- (c) The equation for water boiling at $100^\circ C$ is shown below in Equation Two.

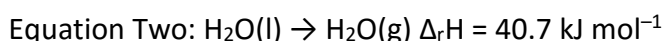

Explain why this equation is endothermic.

You should relate the energy changes that are occurring to the specific bonds being broken or formed.

- (d) A student heats 72.0 g of water to $100^\circ C$ using a Bunsen burner.

● CHEMISTRY

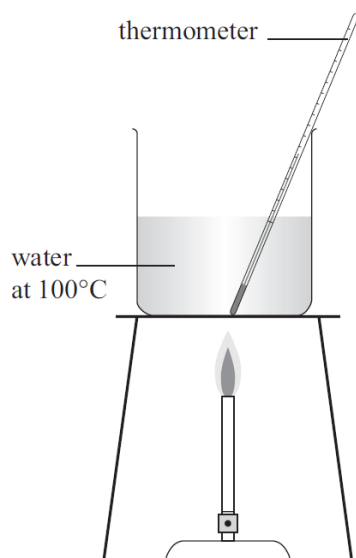

The student then boils the water.

Calculate the mass of methane gas, CH_4 , that would need to be combusted in a Bunsen burner to boil the 72.0 g of water.

$M(\text{H}_2\text{O}) = 18.0 \text{ g mol}^{-1}$.

In your answer you will need to:

- use **Equation Two** to determine the amount of energy required to boil the water
- use **Equation One** to determine the mass of methane needed to produce the required amount of energy
- assume that no energy is lost to the surrounding environment.

QUESTION (2011:4)

- (a) For each of the following, circle the correct word to indicate whether it is an exothermic or endothermic change.

Give a reason for your choice.

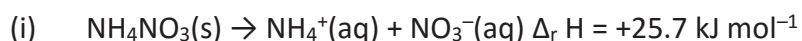

exothermic **endothermic**

Reason:

- (ii) Water vapour condensing, forming rain.

exothermic **endothermic**

Reason:

- (b) The overall reaction occurring in many disposable hand warmers can be represented by:

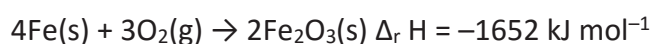

- (i) Calculate the energy released when 1.00 mol Fe_2O_3 is produced.
(ii) Calculate the mass of Fe that would be required to release 185 kJ of energy.

$M(\text{Fe}) = 55.9 \text{ g mol}^{-1}$.

● CHEMISTRY

- (iii) Many types of hand warmers are reusable. When these hand warmers are activated, heat is generated during the rapid crystallisation from liquid to solid. They can be “recharged” by putting them in a pot of boiling water for ten minutes.

Explain, in terms of thermochemical principles, how hand warmers can be recharged by heating.

- (c) Hydrogen and methane can be used as fuels.

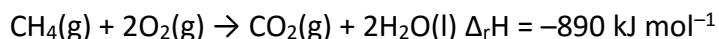
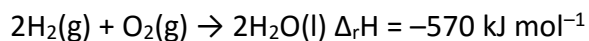

Determine which of the fuels, hydrogen or methane, provides the most energy per gram of fuel burned. Justify your answer with calculations.

$$M(\text{H}_2) = 2.00 \text{ g mol}^{-1} \quad M(\text{CH}_4) = 16.0 \text{ g mol}^{-1}$$

QUESTION (2010:3) (parts (a) and (c))

- (a) Classify the following reactions, by writing in the box below the word ‘**Exothermic**’ or ‘**Endothermic**’.

	Exothermic or Endothermic
$\text{C}_2\text{H}_4(\text{g}) + \text{H}_2\text{O}(\text{g}) \rightarrow \text{C}_2\text{H}_5\text{OH}(\text{g}) \quad \Delta_r\text{H} = -48.0 \text{ kJ mol}^{-1}$	
$\text{H}_2\text{O}(\text{g}) \rightarrow \text{H}_2\text{O}(\text{l})$	
$\text{CH}_4(\text{g}) + \text{H}_2\text{O}(\text{g}) \rightarrow \text{CO}(\text{g}) + 3\text{H}_2(\text{g})$ 206 kJ of energy is absorbed.	
When zinc powder reacts with copper sulfate solution, the temperature rises.	

● CHEMISTRY

- (c) When a 12.2 g sample of ammonia is burned, 275 kJ of energy is released.
Calculate the energy released for the reaction below, when four moles of ammonia are burned.

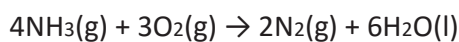

$$M(\text{NH}_3) = 17.0 \text{ g mol}^{-1}$$

QUESTION (2009:2)

- (a) For the reaction $4\text{NH}_3(\text{g}) + 5\text{O}_2(\text{g}) \rightleftharpoons 4\text{NO}(\text{g}) + 6\text{H}_2\text{O}(\text{g})$,
the enthalpy of reaction is $\Delta_r H = -950 \text{ kJ mol}^{-1}$.

The reverse reaction is $4\text{NO}(\text{g}) + 6\text{H}_2\text{O}(\text{g}) \rightleftharpoons 4\text{NH}_3(\text{g}) + 5\text{O}_2(\text{g})$

Two energy diagrams are shown below. One is for the forward reaction and one is for the same reaction in the reverse direction.

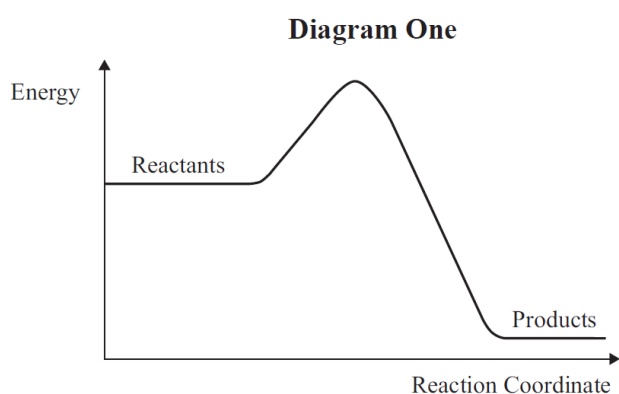

Exothermic or **Endothermic**

(circle one)

Forward or **Reverse**

(circle one)

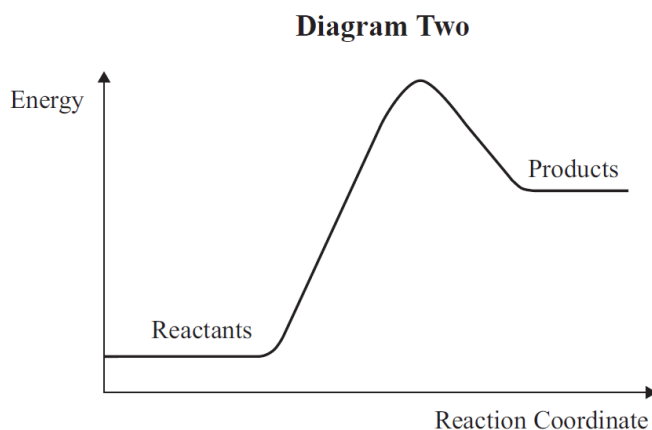

Exothermic or **Endothermic**

(circle one)

Forward or **Reverse**

(circle one)

- (i) For each diagram, **circle** the correct answer to indicate whether the diagram is for an **exothermic** reaction or an **endothermic** reaction.
- (ii) For each diagram, **circle** the correct answer to indicate whether the diagram is for the **forward** reaction or for the **reverse** reaction.
- (iii) On the diagrams for **both** reactions, also label the following:
- enthalpy of reaction, $\Delta_r H$
 - Activation Energy, E_a .
- (iv) Determine the value for the enthalpy of reaction ($\Delta_r H$) for the reaction shown in **Diagram Two**.
Explain how you determined this value.
- (b) The energy diagram below represents a reaction carried out at 20°C.

● CHEMISTRY

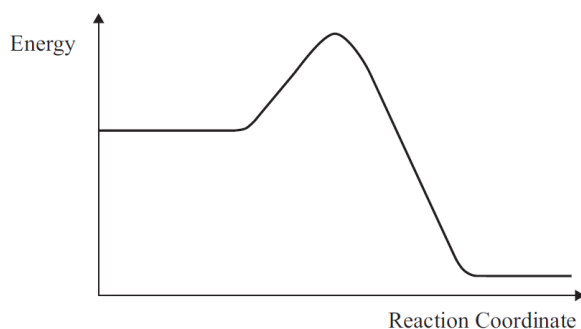

- (i) On the same axes, redraw the energy diagram to show the same reaction carried out at a higher temperature.
- (ii) Explain any changes to
- enthalpy of reaction, $\Delta_r H$
 - Activation Energy, E_a
 - energy of the reactants
 - energy of the products.
- (c) The equation for the reaction between calcium oxide, CaO, and water can be represented as
 $\text{CaO(s)} + \text{H}_2\text{O(l)} \rightarrow \text{Ca(OH)}_2\text{(aq)} \quad \Delta H = -82.0 \text{ kJ mol}^{-1}$
 $M(\text{CaO}) = 56.0 \text{ g mol}^{-1}$

Calculate the mass of calcium oxide required to release 287 kJ of energy.

QUESTION (2008: 5)

When an 18.4 g sample of ethanol is burned, 546 kJ of energy is released.

Determine the enthalpy change, $\Delta_r H$, for the reaction when one mole of ethanol is burned.

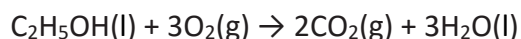

$$M(\text{C}_2\text{H}_5\text{OH}) = 46.0 \text{ g mol}^{-1}$$

QUESTION (2007:4)

- (a) Classify the following reactions as exothermic or endothermic by writing in the box the word that best represents each equation.

		Exothermic or Endothermic
(i)	$\text{NaOH(aq)} + \text{HCl(aq)} \rightarrow \text{NaCl(aq)} + \text{H}_2\text{O}$ A temperature increase occurs.	
(ii)	$\text{N}_2\text{(g)} \rightarrow 2\text{N(g)} \quad \Delta_r H = +934 \text{ kJ mol}^{-1}$	
(iii)	$\text{H}_2\text{(g)} + \text{I}_2\text{(g)} \rightarrow 2\text{HI(g)}$ A temperature decrease occurs.	
(iv)	$2\text{H}_2\text{(g)} + \text{CO(g)} \rightarrow \text{CH}_3\text{OH(g)} \quad \Delta_r H = -128 \text{ kJ mol}^{-1}$	

- (b) Dissolving of ammonium nitrate in water is an endothermic process.

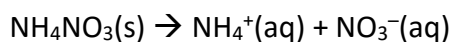

● CHEMISTRY

- (i) When 1.80 g of ammonium nitrate was dissolved in 50.0 g of water, the temperature decreased by 2.70°C. The heat capacity of water is 4.18 J g⁻¹ °C⁻¹. M(NH₄NO₃) = 80.0 g mol⁻¹
Calculate the enthalpy change when one mole of ammonium nitrate dissolves completely in water.
- (ii) Calculate the mass of ammonium nitrate that would be required to absorb 1.25 kJ of energy.

QUESTION (2007:6) (parts (b) & (c))

For the reaction $\text{N}_2(\text{g}) + 3\text{H}_2(\text{g}) \rightleftharpoons 2\text{NH}_3(\text{g})$,

the enthalpy of reaction $\Delta_r H = -92 \text{ kJ mol}^{-1}$, and the activation energy $E_a = +143 \text{ kJ mol}^{-1}$.

An energy diagram for this chemical reaction is shown below.

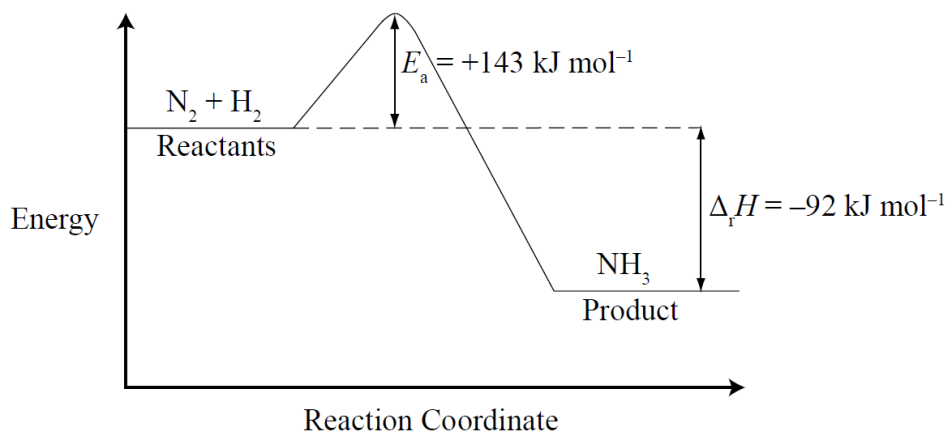

The reverse reaction is $2\text{NH}_3(\text{g}) \rightleftharpoons \text{N}_2(\text{g}) + 3\text{H}_2(\text{g})$

- (b) State the values for $\Delta_r H$ and E_a for this reverse reaction.

$\Delta_r H = \underline{\hspace{2cm}}$ kJ mol⁻¹

$E_a = \underline{\hspace{2cm}}$ kJ mol⁻¹

- (c) Draw the energy diagram below for this reverse reaction.

Label the diagram with the four labels from the key list.

KEY LIST: N₂ + H₂ NH₃ Δ_rH E_a

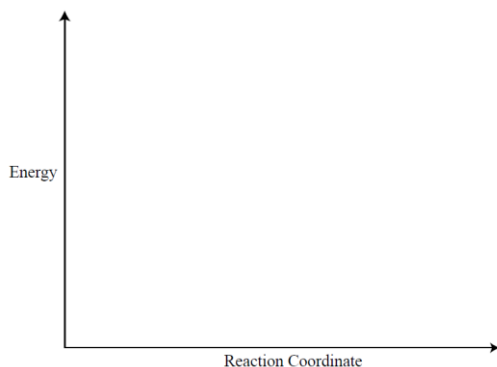

ANSWERS

QUESTION (2015:1)

(d) Ethene gas, $C_2H_4(g)$, reacts with bromine gas, $Br_2(g)$, as shown in the equation below.

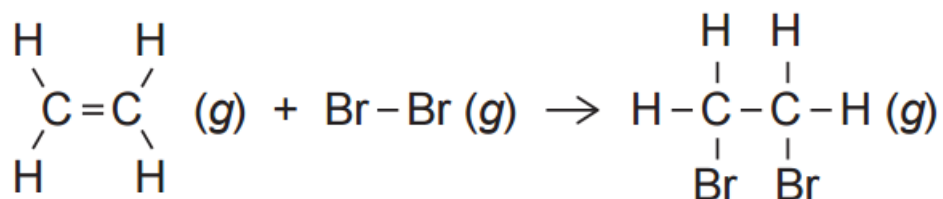

Calculate the enthalpy change, $\Delta_r H^\circ$, for the reaction between ethene and bromine gases, given the average bond enthalpies in the table below. Show your working and include appropriate units in your answer.

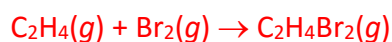

<u>Bonds broken</u>		<u>Bonds formed</u>	
C=C	614	C-C	346
Br-Br	<u>193</u>	C-Br	<u>2 × 285</u>
	807		916

$$\begin{aligned}
 \Delta_r H^\circ &= \Sigma \text{Bond energies (bonds broken)} - \Sigma \text{Bond energies (bonds formed)} \\
 &= 807 - 916 \quad (\text{or } 2463 - 2572) \\
 &= -109 \text{ kJ mol}^{-1}
 \end{aligned}$$

(Alternative calculation that includes the breaking and reforming of four C-H bonds will also be accepted to Excellence level.)

QUESTION (2015:2)

(b) Hand warmers contain a supersaturated solution of sodium ethanoate which, when activated, crystallises and releases heat. Circle the term that best describes this reaction.

exothermic endothermic

Give a reason for your choice.

Exothermic because the temperature of the solution increases / heat is released / particles slow down / bonds are formed

(b) (i) Glucose is made in plants during photosynthesis when carbon dioxide gas, $CO_2(g)$, and water, $H_2O(l)$, react to produce glucose, $C_6H_{12}O_6(aq)$, and oxygen gas, $O_2(g)$. The photosynthesis reaction can be represented by the following equation: $6CO_2(g) + 6H_2O(l) \rightarrow C_6H_{12}O_6(aq) + 6O_2(g)$ $\Delta_r H^\circ = 2803 \text{ kJ mol}^{-1}$

Circle the term that best describes this reaction.

exothermic endothermic

Give a reason for your choice.

Endothermic because the $\Delta_r H^\circ$ value is positive / it uses the sun's energy

● CHEMISTRY

- (ii) Calculate how much energy is absorbed or released in the photosynthesis reaction if 19.8 g of carbon dioxide gas, $\text{CO}_2(\text{g})$, reacts completely with excess water, $\text{H}_2\text{O}(\text{l})$, to form glucose, $\text{C}_6\text{H}_{12}\text{O}_6(\text{aq})$, and oxygen gas, $\text{O}_2(\text{g})$. Show your working and include appropriate units in your answer. $M(\text{CO}_2) = 44.0 \text{ g mol}^{-1}$.

$$n(\text{CO}_2) = m/M = 19.8/44.0$$

$$n(\text{CO}_2) = 0.450 \text{ mol}$$

Since 6 moles of CO_2 reacting requires 2803 kJ of energy

then 1 mole of CO_2 reacting requires $2803/6 = 467.2 \text{ kJ}$ of energy

and 0.450 moles of CO_2 requires $467.2 \times 0.450 = 210 \text{ kJ}$ of energy absorbed.

- (d) A small camp stove containing butane gas, $\text{C}_4\text{H}_{10}(\text{g})$, is used to heat some water, as shown in the diagram below. A student measures the temperature change in the water and calculates that when 3.65 g of butane is combusted, 106 kJ of heat is released.

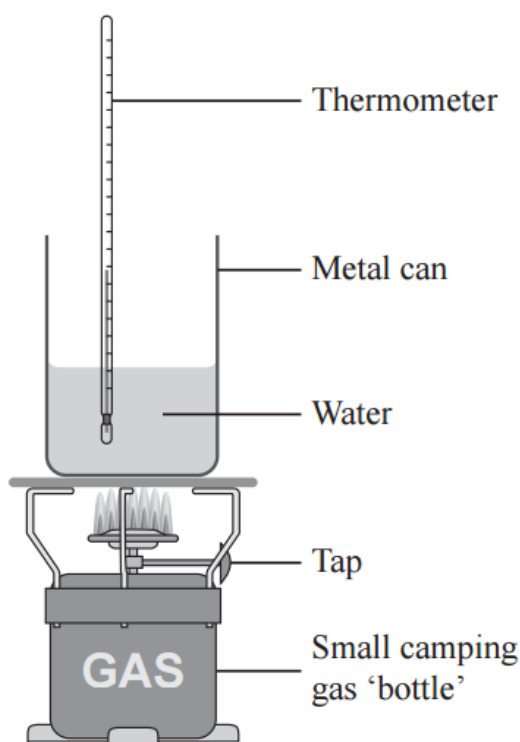

The reaction for the combustion of butane is shown in the equation below.

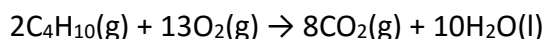

- (i) Calculate the enthalpy change ($\Delta_r H$) for this reaction, based on the above measurements. $M(\text{C}_4\text{H}_{10}) = 58.0 \text{ g mol}^{-1}$.
- $$n(\text{C}_4\text{H}_{10}) = 3.65/58.0 = 0.0629 \text{ mol}$$
- If 0.0629 moles of C_4H_{10} releases 106 kJ of energy
 Then 1 mole of C_4H_{10} releases $106/0.0629 = 1685 \text{ kJ}$ of energy
 And 2 moles of C_4H_{10} releases $1685 \times 2 = 3370 \text{ kJ}$ of energy (3368) ($\Delta_r H = -3370 \text{ kJ mol}^{-1}$)
- (ii) The accepted enthalpy change for the combustion reaction of butane gas, $\text{C}_4\text{H}_{10}(\text{g})$, is $\Delta_r H = -5754 \text{ kJ mol}^{-1}$. Explain why the result you calculated in part (c)(i) is different to the accepted value. In your answer, you should include at least TWO reasons.

● CHEMISTRY

The results from this experiment are less than the accepted results, due to errors in the experimental design. The errors could include:

1. Some energy is used to heat the metal can and the air surrounding the experiment / the experiment was not conducted in a closed system
2. Incomplete combustion of butane.
3. Some butane may have escaped before being ignited.
4. The butane in the gas canister was impure.
5. Some water evaporated
6. Some energy was converted to light and sound
7. Not carried out under standard conditions

Therefore, not all of the energy released by the combustion of butane was transferred to heating the water.

- (iii) Complete, including labels, the energy diagram for the combustion of butane gas showing reactants, products, and the change in enthalpy.

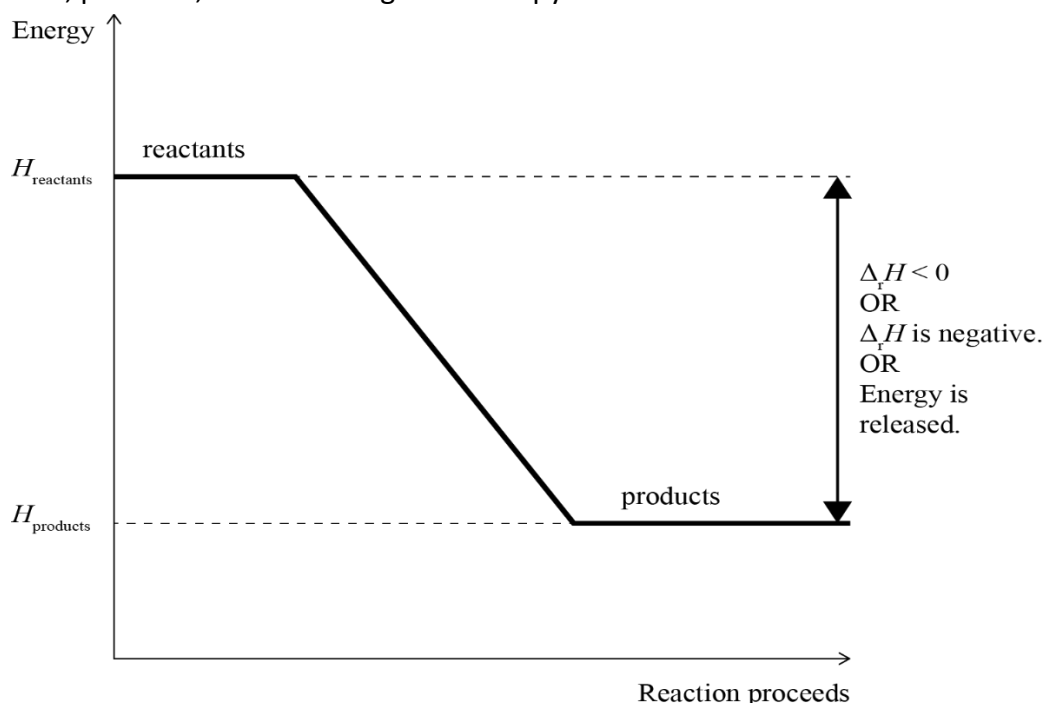

- (v) Butane gas is a useful fuel because when it undergoes combustion, energy is released. Explain why energy is released in this reaction, in terms of making and breaking bonds. No calculations are required.

When butane undergoes combustion, heat is released, so it is an exothermic reaction. Bond-making is an exothermic process / releases energy and bond-breaking is endothermic / requires energy. For the overall reaction in the combustion of butane to release energy, more energy is given out as bonds are made (when the products, CO_2 and H_2O are formed) than the energy being used to break the bonds (in the reactants, C_4H_{10} and O_2)

QUESTION (2014:1)

- (d) Hydrogen gas, $\text{H}_2(g)$, reacts with oxygen gas, $\text{O}_2(g)$, as shown by the following equation

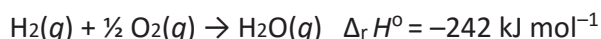

● CHEMISTRY

Given the average bond enthalpies in the table below, calculate the average bond enthalpy of the O – H bond in H₂O.

Bond	Average bond enthalpy / kJ mol ⁻¹
H – H	436
O = O	498

$$\Delta_r H^\circ = \Sigma(\text{bonds broken}) - \Sigma(\text{bonds formed})$$

Bonds broken

$$\text{H-H} = 436 \text{ and } \frac{1}{2} \times \text{O=O} = \frac{1}{2} \times 498$$

$$\text{Total} = 685 \text{ kJ}$$

Bonds formed

$$2 \times \text{O-H}$$

$$\Sigma(\text{bonds formed}) = \Sigma(\text{bonds broken}) - \Delta_r H^\circ = 685 - (-242) = 927 \text{ kJ}$$

$$2 \times \text{O-H} = 927 \text{ kJ and so O-H} = 464 \text{ (463.5) kJ mol}^{-1}$$

QUESTION (2014:3)

- (a) (i) When solid sodium hydroxide is added to water, the temperature increases. Circle the term that best describes this reaction.

Exothermic Endothermic

Give a reason for your choice.

Exothermic, as the temperature increases, which shows energy is being released.

- (ii) The freezing of water to form ice can be represented by the following equation.

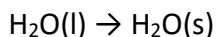

Circle the term that best describes this reaction.

Exothermic Endothermic

Explain your choice.

Exothermic, weak intermolecular attractions form between the water molecules, this releases energy.

- (c) Methanol and ethanol can both be used as fuels. Their combustion reactions can be represented by the following equations:

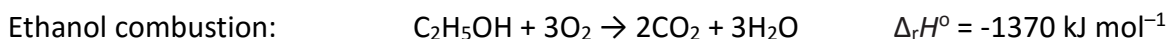
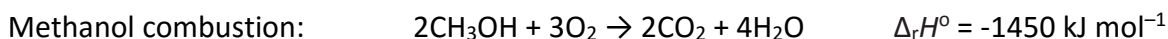

Justify which fuel, methanol or ethanol, will produce more heat energy when 345 g of each fuel is combusted in excess oxygen.

$$M(\text{CH}_3\text{OH}) = 32.0 \text{ g mol}^{-1}$$

$$M(\text{C}_2\text{H}_5\text{OH}) = 46.0 \text{ g mol}^{-1}$$

● CHEMISTRY

$$n(\text{CH}_3\text{OH}) = m / M = 345 / 32 = 10.78 \text{ mol}$$

$$n(\text{C}_2\text{H}_5\text{OH}) = m / M = 345 / 46 = 7.50 \text{ mol}$$

2 mol CH_3OH releases 1 450 kJ of energy

1 mol CH_3OH releases 725 kJ of energy

10.78 mol CH_3OH releases $725 \text{ kJ} \times 10.78 = 7\,816 \text{ kJ}$ of energy

1 mol $\text{C}_2\text{H}_5\text{OH}$ releases 1 370 kJ of energy

7.5 mol $\text{C}_2\text{H}_5\text{OH}$ releases $1\,370 \text{ kJ} \times 7.5 = 10\,275 \text{ kJ}$ of energy

Therefore $\text{C}_2\text{H}_5\text{OH}$ releases more energy when 345 g of fuel are combusted.

QUESTION (2013:2)

- (c) Chlorine reacts with methane to form chloromethane and hydrogen chloride, as shown in the equation below.

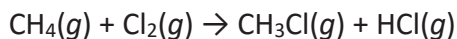

Use the following bond enthalpies to calculate $\Delta_r H^\circ$ for this reaction.

Bond	Bond enthalpy / kJ mol^{-1}
H – Cl	431
C – H	414
C – Cl	324
Cl – Cl	242

Bonds broken C-H x 1 & Cl-Cl x 1 $414 + 242 = 656$

Bonds formed C-Cl x 1 & H-Cl x 1 $-324 + -431 = -755$

$656 + -755 = -99.0 \text{ kJ mol}^{-1}$.

OR

Bonds broken C-H x 4 & Cl-Cl x 1 $1656 + 242 = 1898$

Bonds formed C-Cl x 1 & C-H x 3 H-Cl x 1 $-324 + -1242 + -431 = -1997$

$1898 + -1997 = -99.0 \text{ kJ mol}^{-1}$.

QUESTION (2013:3)

- (a) Dissolving ammonium nitrate in a beaker containing water can be represented by the following equation:

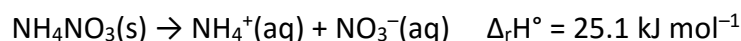

Circle the term below that best describes this process.

exothermic **endothermic**

Circle the description below that best describes what you would observe happening to the beaker during this process.

● CHEMISTRY

gets colder stays the same gets warmer

Explain your choices.

The process is endothermic since the enthalpy change ($\Delta_r H^\circ$) is positive, which indicates that energy is absorbed by the system as the ammonium nitrate dissolves. Since heat energy is absorbed by the system from the surroundings (water & beaker), the **water or beaker** will get cooler as they lose heat energy.

- (b) Glucose is an important source of energy in our diet. The equation below shows the combustion of glucose to form carbon dioxide and water.

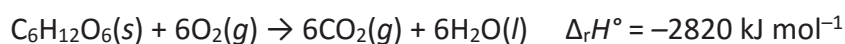

- (i) Circle the term below that best describes this process.

exothermic endothermic

Give a reason for your choice.

The reaction is exothermic because the enthalpy change ($\Delta_r H^\circ$) is negative; indicating that heat energy is produced during the reaction.

- (ii) Females who are moderately active need 9 800 kJ of energy per day.
Calculate the number of moles of glucose that would provide this daily energy requirement.

$$9800 \text{ kJ} / 2820 \text{ kJ mol}^{-1} = 3.48 \text{ mol}$$

- (c) (i) Many portable BBQ and camping gas canisters contain butane, C_4H_{10} . Butane is a gas at room temperature, and has a boiling point of -0.5°C . The gas canisters contain both gas and liquid butane. As the gaseous butane is used, some of the liquid evaporates.

Circle the term below that best describes this process.

exothermic **endothermic**

Give a reason for your choice, and use your knowledge of structure and bonding, and energy changes, to explain the changes occurring as the liquid evaporates.

Heat energy is needed to change the butane from a liquid to a gas; the energy is used to break the weak intermolecular forces between the butane molecules.

- (ii) The equation below shows the combustion of butane.

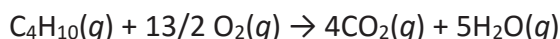

When 100 g of butane undergoes combustion, 4960 kJ of energy is released.

Calculate the enthalpy change when 1 mole of butane undergoes combustion.

$$M(\text{C}_4\text{H}_{10}) = 58.1 \text{ g mol}^{-1}$$

$$n(\text{C}_4\text{H}_{10}) = 100 \text{ g} / 58.1 \text{ g mol}^{-1}$$

$$= 1.7212 \text{ mol}$$

$$-4960 \text{ kJ} / 1.7212 \text{ mol} = -2882 \text{ kJ mol}^{-1}$$

- (d) The iron oxides Fe_3O_4 and Fe_2O_3 react with aluminium as shown below.

● CHEMISTRY

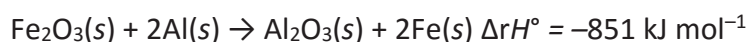
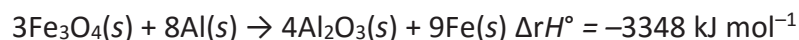

Justify which iron oxide, Fe_3O_4 or Fe_2O_3 , will produce more heat energy when 2.00 kg of iron is formed during the reaction with aluminium.

Your answer should include calculations of the heat energy produced for the given mass of iron formed.

$$M(\text{Fe}) = 55.9 \text{ g mol}^{-1}.$$

$$n(\text{Fe}) = 2000 \text{ g} / 55.9 \text{ g mol}^{-1} = 35.78 \text{ mol}$$

$$\text{Fe}_3\text{O}_4: 3348 \text{ kJ} / 9 = 372 \text{ kJ mol}^{-1}$$

$$372 \text{ kJ mol}^{-1} \times 35.78 \text{ mol} = 13\,310.16 \text{ kJ}$$

$$= 1.33 \times 10^4 \text{ kJ (produced / released)}$$

$$\text{Fe}_2\text{O}_3: 851 \text{ kJ} / 2 = 425.5 \text{ kJ mol}^{-1}$$

$$425.5 \text{ kJ mol}^{-1} \times 35.78 \text{ mol} = 15\,224.4 \text{ kJ}$$

$$= 1.52 \times 10^4 \text{ kJ (produced / released)}$$

Therefore Fe_2O_3 produces more heat energy when 2 kg iron is formed.

QUESTION (2012:3)

- (a) Some Bunsen burners use methane gas, CH_4 , as a fuel. The reaction for the combustion of methane in a Bunsen burner is shown in Equation One below.



When this reaction occurs, bonds are broken and bonds are formed.

State which bonds are broken and which bonds are formed during the reaction.

Bonds broken: **C–H and O=O**

Bonds formed: **C=O and O–H**

- (b) Calculate the energy released when 128 g of methane is burnt.

$$M(\text{CH}_4) = 16.0 \text{ g mol}^{-1}.$$

$$128 \text{ g} / 16.0 \text{ g mol}^{-1} = 8.00 \text{ mol}$$

$$8.00 \text{ mol} \times 889 \text{ kJ mol}^{-1} = 7112 \text{ kJ}$$

- (c) The equation for water boiling at 100°C is shown below in Equation Two.

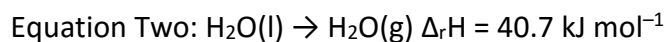

Explain why this equation is endothermic.

You should relate the energy changes that are occurring to the specific bonds being broken or formed.

The reaction is endothermic, as ΔH is positive and because the water is absorbing energy from the flame. During this reaction the weak intermolecular forces between water molecules are broken. Energy is needed to break these attractive forces so the reaction is endothermic.

● CHEMISTRY

(d) A student heats 72.0 g of water to 100°C using a Bunsen burner.

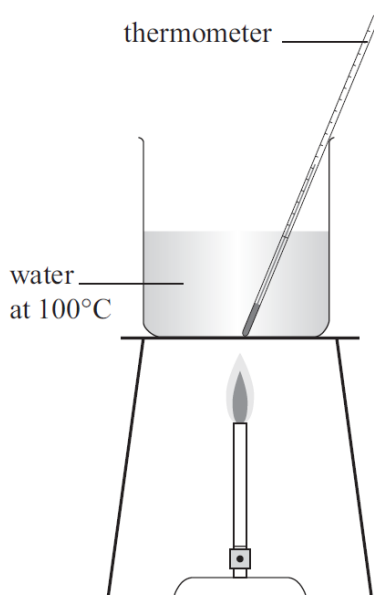

The student then boils the water.

Calculate the mass of methane gas, CH₄, that would need to be combusted in a Bunsen burner to boil the 72.0 g of water.

$M(\text{H}_2\text{O}) = 18.0 \text{ g mol}^{-1}$.

In your answer you will need to:

- use **Equation Two** to determine the amount of energy required to boil the water
- use **Equation One** to determine the mass of methane needed to produce the required amount of energy
- assume that no energy is lost to the surrounding environment.

$72.0 \text{ g} / 18.0 \text{ g mol}^{-1} = 4.00 \text{ mol}$ of water being boiled.

Energy required to do this $4.00 \text{ mol} \times 40.7 \text{ kJ mol}^{-1} = 162.8 \text{ kJ}$

This is the amount of energy that the combustion of methane in the Bunsen is required to produce.

$162.8 \text{ kJ} / 889 \text{ kJ mol}^{-1} = 0.183 \text{ mol}$ of methane to be combusted.

Mass of methane = $0.183 \text{ mol} \times 16.0 \text{ g mol}^{-1} = 2.93 \text{ g}$.

QUESTION (2011:4)

(a) For each of the following, circle the correct word to indicate whether it is an exothermic or endothermic change.

Give a reason for your choice.

(i) $\text{NH}_4\text{NO}_3(\text{s}) \rightarrow \text{NH}_4^+(\text{aq}) + \text{NO}_3^-(\text{aq}) \Delta_f H = +25.7 \text{ kJ mol}^{-1}$

exothermic **endothermic**

Reason: positive: value

(ii) Water vapour condensing, forming rain.

exothermic endothermic

● CHEMISTRY

Reason: **bonds form OR energy released**

(b) The overall reaction occurring in many disposable hand warmers can be represented by:

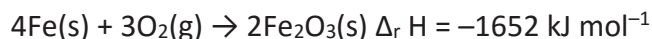

(i) Calculate the energy released when 1.00 mol Fe_2O_3 is produced.

$$1652 / 2.00 = 826 \text{ kJ mol}^{-1} \text{ (kJ)}$$

(ii) Calculate the mass of Fe that would be required to release 185 kJ of energy.

$$M(\text{Fe}) = 55.9 \text{ g mol}^{-1}$$

4 mol Fe releases 1652 kJ of energy so $(4 \times 185)/1652$ mol of Fe would be needed = 0.448 mol

$$m(\text{Fe}) = nM = 0.448 \text{ mol} \times 55.9 \text{ g mol}^{-1} = 25.0 \text{ g}$$

(iii) Many types of hand warmers are reusable. When these hand warmers are activated, heat is generated during the rapid crystallisation from liquid to solid. They can be “recharged” by putting them in a pot of boiling water for ten minutes.

Explain, in terms of thermochemical principles, how hand warmers can be recharged by heating.

Bonds broken OR Melting is endothermic

(c) Hydrogen and methane can be used as fuels.

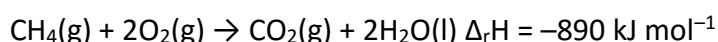
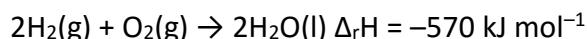

Determine which of the fuels, hydrogen or methane, provides the most energy per gram of fuel burned. Justify your answer with calculations.

$$M(\text{H}_2) = 2.00 \text{ g mol}^{-1} \quad M(\text{CH}_4) = 16.0 \text{ g mol}^{-1}$$

$$m(\text{H}_2) = nM = 2 \text{ mol} \times 2 \text{ g mol}^{-1} = 4 \text{ g}$$

$$n(\text{H}_2) \text{ in } 1 \text{ g} = m/M = \frac{1}{2} = 0.5 \text{ mol}$$

$$\text{Energy per mol } (\text{H}_2) = 570/2 = 285 \text{ kJ mol}^{-1}$$

$$\text{Energy per g } (\text{H}_2) = 285 \times 0.5 = 143 \text{ kJ g}^{-1}$$

$$m(\text{CH}_4) = nM = 1 \text{ mol} \times 16 \text{ g mol}^{-1} = 16 \text{ g}$$

$$n(\text{CH}_4) = m/M = 1/16 = 0.0625 \text{ mol}$$

$$\text{Energy per g } (\text{CH}_4) = 0.0625 \times 890 = 55.6 \text{ kJ g}^{-1}$$

H_2 provides the most energy per gram of fuel

QUESTION (2010:3) (parts (a) and (c))

(b) Classify the following reactions, by writing in the box below the word ‘**Exothermic**’ or ‘**Endothermic**’.

	Exothermic or Endothermic
$\text{C}_2\text{H}_4(g) + \text{H}_2\text{O}(g) \rightarrow \text{C}_2\text{H}_5\text{OH}(g) \quad \Delta_r H = -48.0 \text{ kJ mol}^{-1}$	exothermic
$\text{H}_2\text{O}(g) \rightarrow \text{H}_2\text{O}(l)$	exothermic
$\text{CH}_4(g) + \text{H}_2\text{O}(g) \rightarrow \text{CO}(g) + 3\text{H}_2(g)$ 206 kJ of energy is absorbed.	endothermic
When zinc powder reacts with copper sulfate solution, the temperature rises.	exothermic

● CHEMISTRY

- (c) When a 12.2 g sample of ammonia is burned, 275 kJ of energy is released.
Calculate the energy released for the reaction below, when four moles of ammonia are burned.

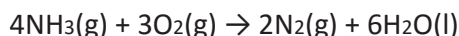

$$M(\text{NH}_3) = 17.0 \text{ g mol}^{-1}$$

$$n(\text{NH}_3) \text{ in } 12.2 \text{ g sample} = 12.2 / 17.0 = 0.718 \text{ mol (3s.f.)}$$

$$4 \text{ mol releases } 4 \times 275 / 0.718 = 1530 \text{ kJ (3s.f.)}$$

QUESTION (2009:2)

- (c) For the reaction $4\text{NH}_3(\text{g}) + 5\text{O}_2(\text{g}) \rightleftharpoons 4\text{NO}(\text{g}) + 6\text{H}_2\text{O}(\text{g})$,
the enthalpy of reaction is $\Delta_r H = -950 \text{ kJ mol}^{-1}$.

The reverse reaction is $4\text{NO}(\text{g}) + 6\text{H}_2\text{O}(\text{g}) \rightleftharpoons 4\text{NH}_3(\text{g}) + 5\text{O}_2(\text{g})$

Two energy diagrams are shown below. One is for the forward reaction and one is for the same reaction in the reverse direction.

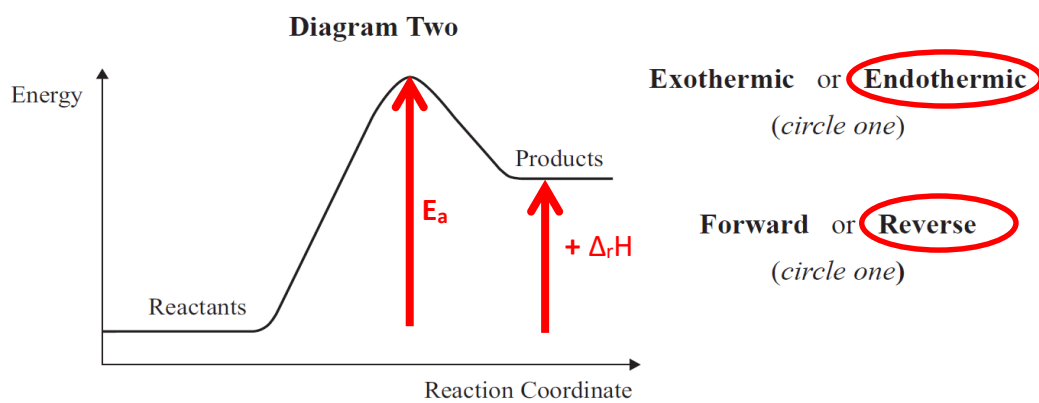
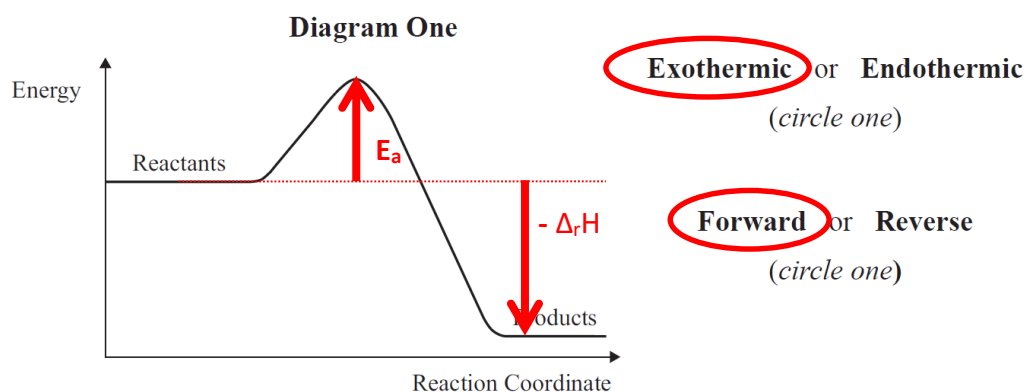

- (i) For each diagram, **circle** the correct answer to indicate whether the diagram is for an **exothermic** reaction or an **endothermic** reaction.
- (ii) For each diagram, **circle** the correct answer to indicate whether the diagram is for the **forward** reaction or for the **reverse** reaction.
- (iii) On the diagrams for **both** reactions, also label the following:

● CHEMISTRY

enthalpy of reaction, Δ_rH

Activation Energy, E_a .

- (iv) Determine the value for the enthalpy of reaction (Δ_rH) for the reaction shown in **Diagram Two**. Explain how you determined this value.

$$\Delta_rH = + 950 \text{ kJ mol}^{-1}$$

Because the same amount of energy is being gained / absorbed / taken in (it is an endothermic reaction) so the Δ_rH is positive.

- (d) The energy diagram below represents a reaction carried out at 20°C.

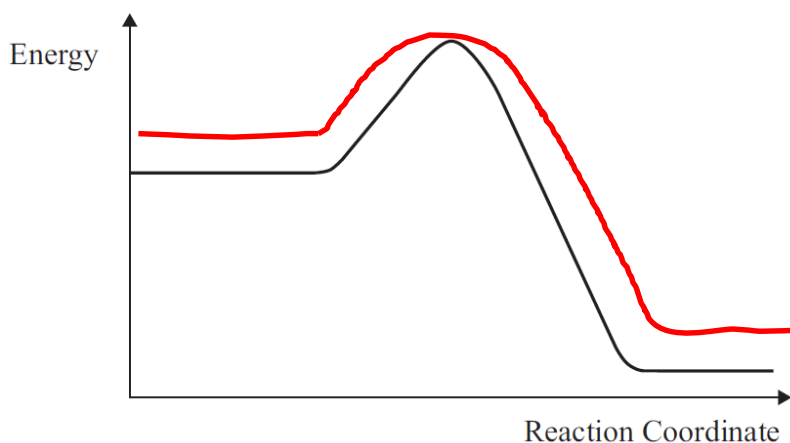

- (i) On the same axes, redraw the energy diagram to show the same reaction carried out at a higher temperature. Diagram redrawn showing the reactants and products having a higher energy, Δ_rH remains the same, with a smaller E_a .
- (ii) Explain any changes to
- enthalpy of reaction, Δ_rH
 - Activation Energy, E_a
 - energy of the reactants
 - energy of the products.

Explanation:

The energy of the reactants and products is higher because with increased temperature the particles have more (kinetic) energy.

The activation energy gap is reduced because the particles have more energy to start with so require less energy for effective / successful collisions.

The Δ_rH will remain the same, this is still the same reaction so regardless of what temperature / how much energy the reactants start with the same amount of energy is released.

- (c) The equation for the reaction between calcium oxide, CaO, and water can be represented as

● CHEMISTRY

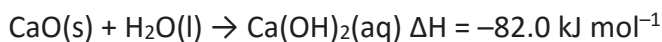

$$M(\text{CaO}) = 56.0 \text{ g mol}^{-1}$$

Calculate the mass of calcium oxide required to release 287 kJ of energy.

$$n(\text{CaO}) = 287 / 82.0 = 3.50$$

$$m(\text{CaO}) = 3.50 \times 56.0 = 196 \text{ g}$$

QUESTION (2008: 5)

When an 18.4 g sample of ethanol is burned, 546 kJ of energy is released.

Determine the enthalpy change, $\Delta_r H$, for the reaction when one mole of ethanol is burned.

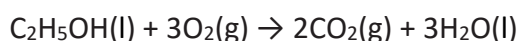

$$M(\text{C}_2\text{H}_5\text{OH}) = 46.0 \text{ g mol}^{-1}$$

$$n(\text{C}_2\text{H}_5\text{OH}) = 18.4/46.0 = 0.400 \text{ mol}$$

$$1 \text{ mol releases } 546/0.400 = 1365 \text{ kJ mol}^{-1}$$

$$\Delta H = -1365 \text{ kJ mol}^{-1}$$

QUESTION (2007:4)

- (a) Classify the following reactions as exothermic or endothermic by writing in the box the word that best represents each equation.

		Exothermic or Endothermic
(i)	$\text{NaOH(aq)} + \text{HCl(aq)} \rightarrow \text{NaCl(aq)} + \text{H}_2\text{O}$ A temperature increase occurs.	Exothermic
(ii)	$\text{N}_2\text{(g)} \rightarrow 2\text{N(g)}$ $\Delta_r H = +934 \text{ kJ mol}^{-1}$	Endothermic
(iii)	$\text{H}_2\text{(g)} + \text{I}_2\text{(g)} \rightarrow 2\text{HI(g)}$ A temperature decrease occurs.	Endothermic
(iv)	$2\text{H}_2\text{(g)} + \text{CO(g)} \rightarrow \text{CH}_3\text{OH(g)}$ $\Delta_r H = -128 \text{ kJ mol}^{-1}$	Exothermic

- (b) Dissolving of ammonium nitrate in water is an endothermic process.

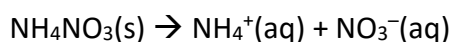

- (i) When 1.80 g of ammonium nitrate was dissolved in 50.0 g of water, the temperature decreased by 2.70°C. The heat capacity of water is 4.18 J g⁻¹ °C⁻¹. $M(\text{NH}_4\text{NO}_3) = 80.0 \text{ g mol}^{-1}$

Calculate the enthalpy change when one mole of ammonium nitrate dissolves completely in water.

$$50.0 \text{ g} \times 2.70^\circ\text{C} \times 4.18 \text{ J g}^{-1} \text{ }^\circ\text{C}^{-1} = 564.3 \text{ J}$$

$$n(\text{NH}_4\text{NO}_3) = 1.80 \text{ g} \div 80 \text{ g mol}^{-1} = 2.25 \times 10^{-2} \text{ mol}$$

Energy absorbed when 1 mol dissolves

● CHEMISTRY

$$= 564.3 \text{ J} \div 2.25 \times 10^{-2} \text{ mol} = 25\,080 \text{ J}$$

$$\Delta_r H = +25.1 \text{ kJ mol}^{-1}$$

- (ii) Calculate the mass of ammonium nitrate that would be required to absorb 1.25 kJ of energy

$$1.25/25.1 = 0.0498 \text{ mol}$$

$$0.0498 \text{ mol} \times 80.0 \text{ g mol}^{-1} = 3.98 \text{ g (or 3.99 g)}$$

(or other correct method)

QUESTION (2007:6)(parts (b) & (c))

For the reaction $\text{N}_2(\text{g}) + 3\text{H}_2(\text{g}) \rightleftharpoons 2\text{NH}_3(\text{g})$,

the enthalpy of reaction $\Delta_r H = -92 \text{ kJ mol}^{-1}$, and the activation energy $E_a = +143 \text{ kJ mol}^{-1}$.

An energy diagram for this chemical reaction is shown below.

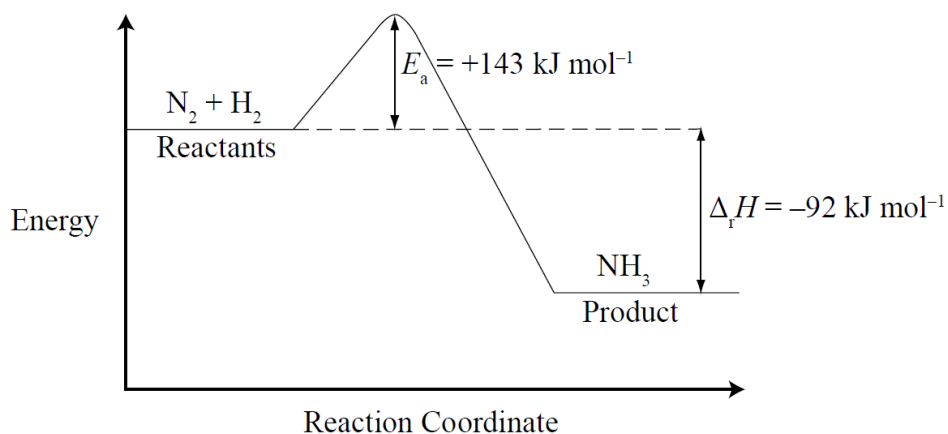

The reverse reaction is $2\text{NH}_3(\text{g}) \rightleftharpoons \text{N}_2(\text{g}) + 3\text{H}_2(\text{g})$

- (b) State the values for $\Delta_r H$ and E_a for this reverse reaction.

$$\Delta_r H = +92 \text{ kJ mol}^{-1}$$

$$E_a = +235 \text{ kJ mol}^{-1} \quad (143 + 92)$$

- (d) Draw the energy diagram below for this reverse reaction.

Label the diagram with the four labels from the key list.

KEY LIST: $\text{N}_2 + \text{H}_2$ NH_3 $\Delta_r H$ E_a

● CHEMISTRY

