

WORKSHOP PROCEEDINGS OF
THE 9TH INTERNATIONAL CONFERENCE ON
INTELLIGENT ENVIRONMENTS

Ambient Intelligence and Smart Environments

The Ambient Intelligence and Smart Environments (AISE) book series presents the latest research results in the theory and practice, analysis and design, implementation, application and experience of *Ambient Intelligence* (AmI) and *Smart Environments* (SmE).

Coordinating Series Editor:
Juan Carlos Augusto

Series Editors:
Emile Aarts, Hamid Aghajan, Michael Berger, Vic Callaghan, Diane Cook, Sajal Das,
Anind Dey, Sylvain Giroux, Pertti Huuskonen, Jadwiga Indulska, Achilles Kameas,
Peter Mikulecký, Daniel Shapiro, Toshiyo Tamura, Michael Weber

Volume 17

Recently published in this series

- Vol. 16. M. d'Angelantonio and J. Oates (Eds.), *Is Ambient Assisted Living the Panacea for Ageing Population?*
- Vol. 15. J. Mintz et al. (Eds.), *Touching the Future Technology for Autism? – Lessons from the HANDS Project*
- Vol. 14. M. Bhatt and H.W. Guesgen (Eds.), *Situational Awareness for Assistive Technologies*
- Vol. 13. J.A. Botía et al. (Eds.), *Workshop Proceedings of the 8th International Conference on Intelligent Environments*
- Vol. 12. T. Bosse (Ed.), *Agents and Ambient Intelligence – Achievements and Challenges in the Intersection of Agent Technology and Ambient Intelligence*
- Vol. 11. J.C. Augusto et al. (Eds.), *Handbook of Ambient Assisted Living – Technology for Healthcare, Rehabilitation and Well-being*
- Vol. 10. J.C. Augusto et al. (Eds.), *Workshop Proceedings of the 7th International Conference on Intelligent Environments*
- Vol. 9. B. Gottfried and H. Aghajan (Eds.), *Behaviour Monitoring and Interpretation – BMI – Well-Being*
- Vol. 8. R. López-Cózar et al. (Eds.), *Workshop Proceedings of the 6th International Conference on Intelligent Environments*
- Vol. 7. E. Mordini and P. de Hert (Eds.), *Ageing and Invisibility*
- Vol. 6. G. van den Broek et al. (Eds.), *AALIANCE Ambient Assisted Living Roadmap*
- Vol. 5. P. Čech et al. (Eds.), *Ambient Intelligence Perspectives II – Selected Papers from the Second International Ambient Intelligence Forum 2009*

ISSN 1875-4163 (print)
ISSN 1875-4171 (online)

Workshop Proceedings of the 9th International Conference on Intelligent Environments

Edited by

Juan A. Botía, *Universidad de Murcia, Spain*
Dimitris Charitos, *Kapodistrian University of Athens, Greece*

Workshop Organizers

Elena Antonopoulou, *National Technical University of Athens, Greece*
Juan Carlos Augusto, *Middlesex University, United Kingdom*
Nikolaos Avouris, *University of Patras, Greece*
Asier Aztiria, *University of Mondragon, Spain*
Alexandra Bounia, *University of Aegean, Greece*
Victor Callaghan, *Essex University, United Kingdom*
Pavel Čech, *University of Hradec Kralove, Czech Republic*
Jeannette Chin, *Anglia Ruskin University, United Kingdom*
Eleni Christopoulou, *University of Patras, Greece*
Diane J. Cook, *Washington State University, USA*
Faiyaz Doctor, *Coventry University, United Kingdom*
Paraskevi G. Fanou, *National Technical University of Athens, Greece*
John Garofalakis, *University of Patras, Greece*
Dimitris M. Hatzopoulos, *Architects Association of Thessaloniki, Greece*
Peter Mikulecký, *University of Hradec Kralove, Czech Republic*
Eleni N. Mitakou, *National Technical University of Athens, Greece*
Athina Papadopoulou, *Massachusetts Institute of Technology, USA*
Dimitris Papanikolaou, *Harvard Graduate School of Design, USA*
Carlos Ramos, *Polytechnic of Porto, Portugal*
Dimitrios Ringas, *Ionian University, Greece*
Maria Roussou, *University of Athens, Greece*
Theodora Vardouli, *Massachusetts Institute of Technology, USA*
Eirini Vouliouri, *National Technical University of Athens, Greece*
Minjuan Wang, *San Diego State University, USA*
Nikoleta Yiannoutsou, *University of Patras, Greece*
Efpraxia D. Zamani, *Athens University of Economics and Business, Greece*
Victor Zamudio, *Instituto Tecnológico de León, Mexico*

IOS
Press

Amsterdam • Berlin • Tokyo • Washington, DC

© 2013 The Author(s).

All rights reserved. No part of this book may be reproduced, stored in a retrieval system, or transmitted, in any form or by any means, without prior written permission from the publisher.

ISBN 978-1-61499-285-1 (print)

ISBN 978-1-61499-286-8 (online)

Library of Congress Control Number: 2013943313

Publisher

IOS Press BV

Nieuwe Hemweg 6B

1013 BG Amsterdam

Netherlands

fax: +31 20 687 0019

e-mail: order@iospress.nl

Distributor in the USA and Canada

IOS Press, Inc.

4502 Rachael Manor Drive

Fairfax, VA 22032

USA

fax: +1 703 323 3668

e-mail: iosbooks@iospress.com

LEGAL NOTICE

The publisher is not responsible for the use which might be made of the following information.

PRINTED IN THE NETHERLANDS

Preface

Humans have been embedding information into their environments or onto the objects that these environments consist of since the ancient years of mankind. Epigraphs and wall paintings are examples of such communication acts.

Information may be communicated to us within an environmental context through a variety of media and accordingly these may support human activities in different ways. For example, signs [1] may communicate secondary environmental information needed to make wayfinding decisions; they tell the user what is where and they also specify when and how an event is likely to occur. Signs, symbols, graphic representations or linguistic communication – spoken or written – are different forms of secondary spatial information sources which may be communicated through a medium to a user in an environment and thus enrich this environment with meaning, ultimately augmenting the experience afforded by this environment. Of course, this information enhances the overall information referring to this environment that the user has already acquired from sensory input, as a result of navigating and interacting, amongst the physical objects that the environments consists of.

Information and Communication Technologies (ICTs) and the new media they support have introduced many new ways of augmenting the experience of physical environments in order to communicate meaning and support several computer-mediated activities or interpersonal mediated communication, amongst individuals who occupy these spaces. Our contemporary urban environment is already filled with various media and appropriate display systems and artifacts¹ which communicate visual and/or auditory content to citizens. These environments may also incorporate systems which capture visual, auditory or other types of data regarding human activity or environmental phenomena, via appropriate sensing devices. Consequently, this input may be utilized for generating relevant actions by several types of effectors or for generating related sequences of multisensory digital representations. It can therefore be suggested [2] that the incorporation of ICT systems results in an electronic enhancement of our everyday urban environment and that our computer supported activities and communication with these environments, at a personal level, or with other citizens who exist and act within them, at a social level, is mediated by these systems. One of the most advanced forms of such systems is Intelligent Environments.

ICTs, whether mobile, wireless or embedded in persistent architectural forms, facilitate the collection and dissemination of data, infusing the physical expression of the environment with digital layers of content, thus contributing to the emergence of new hybridized spatial experiences as well as novel forms of interacting with computers and with other participating humans. These systems and the hybrid spatial experiences they afford, encourage encounters among users; both embodied and mediated, and influence community dynamics, giving rise to networks around common interests and collectives of affect. Sometimes, such groups, irrespective of how ephemeral, unstable and dispersed they may be, negotiate a new kind of engagement with the urban environment

¹Most of these representations are visual, i.e. large size prints, video projections, wall paintings, TV closed circuits, touch screens etc.

and civic life, suggesting thus an organizational paradigm that manages to surpass traditional vertical hierarchies of space and consequently of power and control [3].

It is therefore evident that the deployment of intelligent environment systems and applications has very significant consequences at a psychological, social, political and cultural level for all participants of these experiences as well as for the stake holders involved. Therefore, it is suggested that the processes of designing, developing and evaluating intelligent environments should also be seen from a multidisciplinary perspective in order to assure that these systems will be embedded in our everyday lives and environments in the best possible manner, by taking into account the needs, potential and expected impact that their use may have onto individuals, groups or communities of people. Such an interdisciplinary approach may lead to the creation of ergonomically efficient, aesthetically pleasing and functional Intelligent Environment systems. Accordingly, there is a need for new design practices and methodologies that may take into account the hybrid nature of the spatial experience afforded by these media, as well as the opportunities for socialisation and communication that they may offer. Examples of the disciplines that the production of Intelligent Environments may relate to are: cognitive psychology, environmental psychology, architectural and visual design, urban studies, design studies, social and cultural studies, museum studies, political communication, etc.

The need for a multidisciplinary approach is indeed one of the implicit aims for organizing a series of international workshops for the fifth time in the context of the Intelligent Environments Conference in 2013 which is held in Athens, Greece. This need was adequately accomplished as is evident in the very interesting and challenging international workshops which are included in the program and documented in these proceedings.

This is actually the 9th Intelligent Environments (IE) conference and it is organized by the School of Architecture – National Technical University of Athens (NTUA) and the Hellenic Open University (HOU). The workshops part of the 9th IE conference is organized by the Faculty of Communication and Media Studies of the National and Kapodistrian University of Athens and the Hellenic Open University. Previously, the Intelligent Environments Conference has been successfully organized in Colchester, UK (2005), Athens, Greece (2006), Ulm, Germany (2007), Seattle, USA (2008), Barcelona, Spain (2009), Kuala Lumpur, Malaysia (2010), and Nottingham Trent University, United Kingdom (2011).

The workshops part of the conference is organized with the aim of providing a forum for scientists, researchers and engineers from both industry and academia to discuss about topics related to intelligent environments, ubiquitous computing and ambient intelligence. This year we are pleased to include the following workshops:

- **AITAmI:** The 8th workshop on Artificial Intelligence Techniques for Ambient Intelligence aims at gathering researchers in a variety of AI subfields together with representatives of commercial interests to explore the technology and applications for ambient intelligence. The workshop is organized, once again, by Asier Aztiria (University of Mondragon, Spain), Juan Carlos Augusto (University of Middlesex, United Kingdom), and Diane Cook (Washington State University, USA).
- **ACIE:** The 1st International Workshop on Applications of Affective Computing in Intelligent Environments is organized by Faiyaz Doctor (Coventry University, United Kingdom) and Victor Zamudio (Instituto Tecnológico de

Len, Mexico). This workshop provides a forum to promote and demonstrate how recent development of unobtrusive physiological sensing can be used to capture emotive or physiological information to enhance IE based applications.

- **SOOW:** The Smart Offices and Other Workplaces Workshop is organized by Peter Mikulecky (University of Hradec Kralove, Czech Republic), Pavel Cech from the same university and Carlos Ramos (Polytechnic of Porto's Institute of Engineering, Portugal). This workshop fosters discussion on how ambient intelligence is useful for the development of intelligent workplaces devoted to support working activities.
- **CoT:** The 1st Cloud of Things Workshop is organized by Jeannette Chin (Anglia Ruskin University) and Victor Callaghan (University of Essex). The workshop will discuss on the synergy offered by the combination of the Internet of Things, Cloud Computing, Intelligent Environments and embedded computing.
- **MASIE:** The 1st Workshop on Museums As Intelligent Environments is organized by Nikolaos Avouris (University of Patras, Greece), Alexandra Bounia, Niloketa Yiannoutsou and Maria Roussou. The workshop invites researchers and practitioners of intelligent environments technologies with interest in applying them in museums and sites of culture as well as museologists, curators and museum educators who are interested in investigating and discussing the potential of such technologies for modern museums. The workshop is thus intended to act as a forum for cross-fertilization of ideas between museum experts and researchers of intelligent environments.
- **WOFIEE:** The 2nd Workshop on Future Intelligent Educational Environments is organized By Victor Callaghan (Essex University), Minjuan Wang (San Diego State University), and Juan Carlos Augusto (University of Middlesex, United Kingdom). The focus of the workshop is placed on how intelligent technologies can support the development of new educational technologies and environments around the world.
- **IECL:** The Workshop on Intelligent Environments for Creative Learning is organized by Elena Antonopoulou, Athina Papadopoulou, Theodora Vardouli and Eirini Vouliouri. It aims to bring together theoretical and technical work that explores ways in which intelligent environments can foster learning, enable user creativity, and develop individual and collective design intelligence.
- **SSC:** The 1st Sociable Smart City Workshop is organized by Eleni Christopoulou, Dimitrios Ringas and John Garofalakis. The focus of this workshop is on the social and cultural aspects of the smart city. In particular, the organisers seek to study how urban computing alters the city, the perception of people about the city, the communication among people and the social and cultural impact on the city and on city life. The goal of this workshop is to define what is a "sociable smart city" and how this vision can be realized.
- **IUIC:** The Workshop on Intelligent Users and Intelligent Cities is organized by Dimitris Hatzopoulos, Eleni Mitakou, Paraskevi Fanou and Efraxia Zamani. The main goal of the workshop is to firstly identify users of intelligent environments by giving them characteristics, and then recognize the parameters that establish the city as an intelligent environment, using among our main research instruments the representational arts.

- **CUI:** The 1st Workshop on Constructing Urban Intelligence is organized by Dimitris Papanikolaou (DDes candidate, Harvard GSD). This workshop explores models, methods, and problems of constructing ambient intelligence through human interaction and for this purpose it has invited designers, researchers, and practitioners across multiple disciplinary domains to submit papers with positions on this subject:

We would like to thank everybody who made these proceedings possible, once again for the IE'13. Firstly, we would like to thank each and every workshop's organizing committees. They are the main contributors of this event and without them these workshops would not have been possible. We would also like to thank the local staff who worked really hard to make this series of events a success and the Faculty of Law of the National and Kapodistrian University of Athens who provided significant support for accommodating the workshop activities. Of course we would like to give special thanks to the researchers, who do the hard work, achieve the advances, set the research agenda and then come to Intelligent Environments workshops to present and discuss their insights. We sincerely hope that the audience will find this set of scientific papers interesting and inspiring for their own work. This contribution is our main goal and we believe that succeeding in this effort will ultimately make Intelligent Environments occupy the place they deserve in academia, the industry and the society.

Juan A. Botía and Dimitris Charitos
General chairs of the IE'13 Workshops and Editors of the Book

References

- [1] R. Passini, *Wayfinding in Architecture*, Van Nostrand Reinhold, New York, 1992.
- [2] D. Charitos, "Precedents for the design of Locative Media as hybrid spatial communication interfaces for social interaction within the urban context", in: H. Isomaki (ed.), *Future Interaction Design II*, Springer Verlag, 2008.
- [3] D. Charitos, I. Theona, D. Dragona, C. Rizopoulos & M. Meimaris (eds.), *Subtle Revolutions: Proceedings of the 2nd International Hybrid City Conference*, Athens, 23–25 May 2013, National and Kapodistrian University of Athens, University Research Institute of Applied Communication, Athens, 2013.

Contents

Preface	v
<i>Juan A. Botía and Dimitris Charitos</i>	
8th Workshop on Artificial Intelligence Techniques for Ambient Intelligence (AITAmI'13)	
Introduction to the Proceedings of AITAmI'13	3
<i>Asier Aztiria, Juan C. Augusto and Diane J. Cook</i>	
Multilevel Wavelet Transform Based Sparsity Reduction for Compressive Sensing	4
<i>Zhengmao Ye and Habib Mohamadian</i>	
A Complex Event Processing Based Framework for Intelligent Environments	12
<i>Bilgin Avenoglu and P. Erhan Eren</i>	
Synergetic Tropisms: A Case Study for a Multi-Performative Design Concept	24
<i>Efthymia Kasimati and Eleanna Panagoulia</i>	
Cardiac Arrhythmia Classification Using KNN and Naive Bayes Classifiers Optimized with Differential Evolution (DE) and Particle Swarm Optimization (PSO)	36
<i>Christian Padilla-Navarro, Rosario Baltazar-Flores, David Cuesta-Frau, Arnulfo Alanis-Garza and Victor Zamudio-Rodríguez</i>	
A Generic Context-Aware Recommender Framework for M-Commerce	47
<i>Abdullah Abdullah and Xining Li</i>	
Towards a Component-Based Design of Adaptive, Context-Sensitive Services for Ubiquitous Systems	57
<i>Tomás Ruiz-López, Carlos Rodríguez-Domínguez, Manuel Noguera, María José Rodríguez and José Luis Garrido</i>	
Extraction of Association Rules in Between Socio-Demographics and Biochemistry Datasets of Schizophrenia Patients Using Multi-Objective Genetic Algorithms	69
<i>Buket Kaya and İbrahim Türkoğlu</i>	
Steps Toward End-to-End Personalized AAL Services	78
<i>Amedeo Cesta, Luca Coraci, Gabriella Cortellessa, Riccardo De Benedictis, Andrea Orlandini, Filippo Palumbo and Ales Stimec</i>	
Social Sub-Group Identification Using Social Graph and Semantic Analysis	90
<i>Bjørn Magnus Mathisen, Anders Kofod-Petersen, John McGovern, Thomas Vilarinho and Babak A. Farshchian</i>	

Emotion Analysis Through Physiological Measurements	97
<i>Adrian R. Aguiñaga, Miguel López Ramírez, Armulfo Alanís Garza, Rosario Baltazar and Victor M. Zamudio</i>	

1st International Workshop on Applications of Affective Computing in Intelligent Environments (ACIE'13)

Introduction to the Proceedings of ACIE 2013	109
<i>Faiyaz Doctor and Victor Zamudio</i>	
Social Awareness in Pervasive Communities for Collaborative Work	110
<i>Christopher Lima, Mário Antunes, Diogo Gomes and Rui Aguiar</i>	
Game Based Monitoring and Cognitive Therapy for Elderly	116
<i>Javier Navarro, Victor Zamudio, Faiyaz Doctor, Carlos Lino, Rosario Baltazar, Columba Martínez, Jaime Torres, Luis Bermúdez and Bertha Gutiérrez</i>	
Towards a Ground Truth Dataset for Affect Detection from Physiological Information	128
<i>Patrick Moratori, Christian Wagner, Robert Houghton, Victoria Shipp, Jaspreet Johal, Peter Welch and Shakir Ali</i>	

1st International Workshop on Constructing [Urban] Intelligence (CUI'13). This, Here, Now

Preface	139
<i>Dimitris Papanikolaou</i>	
Co-Modeling Urban Experience	141
<i>Hara Gavra</i>	
End-User No Longer – Rethinking the Design of Distributed Infrastructures Considering Users Participation Through Piezoelectric Technology	150
<i>Elena Vanz, Justyna Karakiewicz and Amnon Holland</i>	
Integrating Game Elements for Increasing Engagement and Enhancing User Experience in a Smart City Context	160
<i>Katerina Diamantaki, Charalampos Rizopoulos, Vasileios Tsetsos, Iouliani Theona, Dimitris Charitos and Nikos Kaimakamis</i>	
Privacy in Intelligent Environments: That Obscure Object of Desire	172
<i>Spyros Ampanavos and George Papoulias</i>	
Sen-Sys: Visualizing Real-Time User Displacement Patterns in Urban Environments	178
<i>Patricia Correa, Alejandra Romo and James Yamada</i>	

1st International Workshop on Cloud-of-Things (CoT'13)

Cloud-of-Things 2013 (CoT'13)	187
<i>Jeannette Chin and Vic Callaghan</i>	

Developing xReality Objects for Mixed-Reality Environments <i>Anasol Peña-Rios, Vic Callaghan, Michael Gardner and Mohammed J. Alhaddad</i>	190
An Internet-Connected World: Google's Platform Strategies to Network Industry <i>Chien-Ming Tung and Hsuan-Yi Wu</i>	201
A DIY Approach to the Internet of Things: A Smart Alarm Clock <i>Gary Scott and Jeannette Chin</i>	214
Genetic Algorithms and Differential Evolution Algorithms Applied to Cyclic Instability Problem in Intelligent Environments with Nomadics Agents <i>Alejandro Sosa, Victor Zamudio, Rosario Baltazar, Vic Callaghan and Efren Mezura</i>	222
Biopolis <i>Vasileios Anagnostopoulos, Emmanuel Sardis, Anastasios Doulamis and Theodora Varvarigou</i>	232
iForest: Exploring Crowd-Based Intelligence as a Means of Improving the Human-Computer Interface in the Cloud-of-Things <i>Idham Ananta, Vic Callaghan, Jeannette Chin, Matthew Ball, Jazi Eko Istiyanto, Susi Daryanti and Michael Gardner</i>	238
A Content-Aware Cloud Platform for Virtual Reality Web Advertising <i>Markos Zampoglou, Athanasios G. Malamos, Emmanuel Sardis, Anastasios Doulamis, Kostas Kapetanakis, Konstantinos Kontakis, Vrettos Moulos and George Vafiadis</i>	246
ViewPoint: An Augmented Reality Tool for Viewing and Understanding Deep Technology <i>Malek Alrashidi, Vic Callaghan, Micheal Gardner and Jennifer B. Elliott</i>	252
IF Alice Arrives, THEN Wonderhome Incites <i>Tiina Kymäläinen</i>	262
The Programmer and the Widow: Exploring the Effects of Total Immersion in Augmented Realities <i>Yu Huang and Hsuan-Yi Wu</i>	274
Talking Things <i>Yevgeniya Kovalchuk</i>	284
An Introduction to Genetic Profiling <i>Marc Davies and Vic Callaghan</i>	294
The Maker Fables <i>Vic Callaghan</i>	306
3rd International Workshop on Smart Offices and Other Workplaces (SOOW'13)	
Foreword to the Proceedings of the 3rd International Workshop on Smart Offices and Other Workplaces (SOOW'13) <i>Peter Mikulecky, Pavel Cech and Carlos Ramos</i>	317

Creating and Optimizing Client-Server Applications on Mobile Devices <i>Ricardo Anacleto, Nuno Luz, Ana Almeida, Lino Figueiredo and Paulo Novais</i>	318
Open Source Based Concept of Intelligent House <i>Miroslav Behan and Ondrej Krejcar</i>	330
Intelligent House – Smart Living and Smart Workplace in Practical Approach <i>Richard Cimler and Karel Mls</i>	338
A Multi-Agents Framework for Contextual and Affective Decision Making <i>Carlos Filipe Freitas, Goreti Marreiros, Ricardo Santos, João Barroso and Carlos Ramos</i>	347
Graphical Interfaces for Development Exploiting the Third Dimension Using Kinect <i>Raul A. Herrera-Acuña, Vasileios Argyriou and Sergio A. Velastin</i>	356
Visual Multi-Agent Argumentation Solver <i>Nuno Lopes, Ricardo Santos and Goreti Merreiros</i>	368
Intelligent Outdoor Spaces <i>Peter Mikulecky</i>	377
Simulation of Visitor Flow Management with Context-Based Information System <i>Kamila Olševičová and Richard Cimler</i>	386
Activities Recognition in Intelligent Office Environment <i>Saifullizam Puteh, Ahmad Lotfi and Caroline Langensiepen</i>	393
Mobile Monitoring System for Elder People Healthcare and AAL <i>Petr Suba and Petr Tucnik</i>	403
 2nd International Workshop on Future Intelligent Educational Environments (WOFIEE 2013)	
Introduction to the Proceedings of WOFIEE'13 <i>Juan C. Augusto, Vic Callaghan and Minjuan Wang</i>	417
A Mobile App for Adaptive Test in Intelligent Tutoring System Based on Competences <i>Miguel Badaracco, Jun Liu and Luis Martinez</i>	419
An Empirical Study on the Effects of Embodied Conversational Agents on User Retention Performance and Perception in a Simulated Mobile Environment <i>Ioannis Doumanis and Serengul Smith</i>	431
Artificial Intelligence in 3D Virtual Environments as Technological Support for Pedagogy <i>Noha Saleeb and Georgios Dafoulas</i>	443

Putting the Buzz Back into Computer Science Education <i>Vic Callaghan, Malcolm Lear, Anasol Peña-Rios, Victor Zamudio and Ping Zheng</i>	454
Towards Adjustable Autonomy in Adaptive Course Sequencing <i>Abdulkareem Alzahrani, Vic Callaghan and Michael Gardner</i>	466
Improving Communication and Presence in Online Telepresence Systems <i>Alfonso Torrejon, Vic Callaghan and Hani Hagrass</i>	478
1st International Workshop on Museums as Intelligent Environments (MASIE'13)	
Museums as Intelligent Environments <i>Nikolaos Avouris, Nikoleta Yiannoutsou, Alexandra Bounia and Maria Roussou</i>	491
Exploring the Effect of Diverse Technologies Incorporated in Virtual Museums on Visitors' Perceived Sense of Presence <i>Stella Sylaiou, Katerina Mania, Ioannis Paliokas, Vassilis Killintzis, Fotis Liarokapis and Petros Patias</i>	493
Improving Museum Visitors' Quality of Experience Through Intelligent Recommendations: A Visiting Style-Based Approach <i>Ioanna Lykourantzou, Xavier Claude, Yannick Naudet, Eric Tobias, Angeliki Antoniou, George Lepouras and Costas Vasilakis</i>	507
Playing in Museums by Constructing Your Game <i>Ines Di Loreto, Monica Divitini, Igoris Trimailovas and Micaela Mander</i>	519
Beyond Artificial Intelligence Markup Language (AIML) Rapid Prototyping of a Q&A System <i>Ioannis Doumanis and Serengul Smith</i>	530
From Personalization to Adaptivity – Creating Immersive Visits Through Interactive Digital Storytelling at the Acropolis Museum <i>Laia Pujol, Akrivi Katifori, Maria Vayanou, Maria Roussou, Manos Karvounis, Marialena Kyriakidi, Stamatia Eleftheratou and Yannis Ioannidis</i>	541
Keynote: Digital-Material Hybrid Objects and Augmented Spaces to Support the Social Experience of Heritage <i>Daniela Petrelli</i>	555
1st International Workshop on Intelligent Environment (f)or Creative Learning (IECL'13)	
Introduction to the Proceedings of IECL 2013 <i>Elena Antonopoulou, Athina Papadopoulou, Theodora Vardoulis and Eirini Vouliouri</i>	561
Spatial Aspects of Active Learning <i>İpek Kay and Mine Özkar</i>	562

Transitional Physicality: The Dadaist Legacy of Creativity in the Digital Age <i>Rodanthi Vardouli</i>	571
Matter and Knowledge Among Digital Communities <i>Maroula Bacharidou and Georgios Adamopoulos</i>	579
Restructuring Beginning Design Curriculums with Visual Calculation <i>Derek Ham</i>	588
Something About Craft <i>Guillermo Bernal</i>	598
Designing Design Heuristics: The Creative Crowd <i>Yaniv Turgeman</i>	604
1st International Workshop on Sociable Smart Cities (SSC'13)	
Introduction to the Proceedings of the Sociable Smart City 2013 Workshop <i>Eleni Christopoulou, Dimitrios Ringas and John Garofalakis</i>	615
A Proxemic Interactive Platform for Sociable Public Zones in the Smart City <i>Huilianing Jin, Bertrand David and René Chalon</i>	617
TRART: A System to Support Territorial Policies <i>Carla Binucci, Walter Didimo, Giuseppe Liotta, Fabrizio Montecchiani and Mariano Sartore</i>	629
Smart City Search: A User Survey <i>Richard Mietz and Kay Römer</i>	635
Pedestrian Navigation and Shortest Path: Preference Versus Distance <i>Iro Armeni and Konstantinos Chorianopoulos</i>	647
The Future of Local Memory Websites as Empowering Niches in Amsterdam <i>Mike de Kreek and Marijke Oosterbroek</i>	653
Helping Tourists to Plan Activities with Shared Urban Social Context <i>Andreas Komninos, Peter Barrie and Jeries Besharat</i>	663
Towards the Sociable Smart City <i>Eleni Christopoulou and Dimitrios Ringas</i>	673
Integrating Modern Mobile Devices in Emergency Event Reporting and Notification <i>Lambros Lambrinos and Karim Bechara</i>	678
'Soundwalk': An Embodied Auditory Experience in the Urban Environment <i>Katerina Talianni and Dimitris Charitos</i>	684
Keynote: Open UBI Oulu <i>Timo Ojala</i>	693
Keynote: Multiplayer Sensor-Based Games Used in Public Spaces <i>Irene Mavrommati</i>	695

1st International Workshop on Intelligent Users, Intelligent Cities (IU/IC'13)

Introduction to the Proceedings of IU/IC 2013 <i>Efpraxia D. Zamani, Eleni N. Mitakou, Paraskevi G. Fanou and Dimitris M. Hatzopoulos</i>	699
From Spectator to User, from Viewer to (Act)or <i>Eleni N. Mitakou, Paraskevi G. Fanou and Efpraxia D. Zamani</i>	700
Neo-Nomad: The Man of the Networks Revolution Era <i>Melina Philippou</i>	709
Precedents for Critically Designing Interaction with Computational Artifacts and Spaces <i>Efrosini Avrami and Dimitris Charitos</i>	722
Modeling Context and Fuzzy Personas Towards an Intelligent Future Internet Smart Home Paradigm <i>Phivos Mylonas, Giorgos Siolas, George Caridakis, Stefanos Kollias and Andreas-Georgios Stafylopatis</i>	732
Open Design Continuum (ODC) <i>Christos Gourdoukis and Spyros Efthymiou</i>	744
Spatiality of Athens' Digital Footprint: Limitations and Opportunities for "Intelligent" Urban Planning <i>Iro Bala and Eirini Moschouti</i>	752
Non Linearity – Text/Cyberspace/City <i>Ioanna Cheinoporou</i>	761
Scripting Cultures, Parametric Urbanism and Adaptive Ecologies <i>Marianna Charitonidou</i>	773
Subject Index	783
Author Index	787

This page intentionally left blank

8th Workshop on Artificial Intelligence Techniques for Ambient Intelligence (AITAmI'13)

Asier Aztiria (University of Mondragon, Spain)

Juan Carlos Augusto (Middlesex University, UK)

Diane J. Cook (Washington State University, USA)

This page intentionally left blank

Introduction to the Proceedings of AITAmI'13

Imagine a future where human environments respond to human preferences and needs. In this world, devices equipped with simple intelligence and the abilities to sense, communicate, and act will be unremarkable features of our world. We will expect the car to warn us of hazards, track our location and provide timely route advice. We will speak to simple machines and hold conversations with more complex systems, such as intelligent homes that will help us monitor conditions, track routine tasks, and program the behaviour of the heater, lights, garden watering and the entertainment centre. Analogous systems at work will make simple decisions in our stead ranging from scheduling meetings to negotiating for common services over the web. Such systems will also acquire, and adapt to our preferences over time. In sum, we will come to view simple software intelligence as an ambient feature of our environment.

Based on this vision, the workshop on Artificial Intelligence Techniques for Ambient Intelligence (AITAmI) was launched in 2006 co-located with the European Conference on Artificial Intelligence. Since 2009, this workshop is co-located with the International Conference on Intelligent Environments (IE). The previous editions of the workshop indicated a significant interest in research related to use of Artificial Intelligence techniques for Ambient Intelligence environments.

This workshop will provide the opportunity to understand latest developments and take action to shape the future of the area by gathering researchers in a variety of AI subfields together with representatives of commercial interests to explore the technology and applications for ambient intelligence.

The workshop organizers deeply thanks the Program Committee and attendees for their participation and interesting discussions.

Asier Aztiria, Juan C. Augusto, and Diane J. Cook
Co-chairs AITAmI'13

Multilevel Wavelet Transform Based Sparsity Reduction for Compressive Sensing

Zhengmao YE^{a,1} and Habib MOHAMADIAN^b

^a*Department of Electrical Engineering, Southern University, Baton Rouge, USA*

^b*College of Engineering, Southern University, Baton Rouge, USA*

Abstract. Compressive sensing has become a popular technique in broad areas of science and engineering for data analysis, which leads to numerous applications in signal and image processing. It exploits the sparseness and compressibility of the data in order to reduce the size. Wavelet analysis is one of leading techniques for compressive sensing. In 2D discrete wavelet transform, the digital image is decomposed with a set of basis functions. At each level, wavelet transform is applied to compute the lowpass outcome (approximation) and highpass outcomes (three details), each with a quarter size of the source image. For the subsequent levels, the lower level outcomes turn out to be the inputs of the higher level to conduct further wavelet decompositions recursively, so that another set of approximation and detail components is generated. Discrete wavelet transform and discrete wavelet packet transform differ in higher levels other than the first level of decomposition. From the second level, discrete wavelet transform applies the transform to the lowpass outcomes exclusively, while wavelet packet transform applies the transform to lowpass and highpass outcomes simultaneously. As the more comprehensive approach, wavelet packet transform is selected for scene image compression on cases of both the lower and higher dynamic range images. Quantitative measures are then introduced to compare the outcomes of two cases.

Keywords. Compressive Sensing, Discrete Wavelet Transform, Wavelet Packet Transform, Sparsity Reduction, Thresholding

1. Introduction

Wavelet analysis has a wide range of applications in math, engineering, computer science, and so on. The related topics cover continuous wavelet transform and discrete wavelet transform, decimated wavelet transform and non-decimated wavelet transform, as well as the multiresolution analysis. The notions of sparsity and thresholding are always emphasized. Different algorithms have been designed and applied, such as the famous Haar wavelets and Haar-Fisz transformation [1-3]. Some fundamental applications have appeared in literatures. An algorithm based on the wavelet-packet transform has been used for the analysis of harmonics in the power systems. It decomposes the voltage and current waveforms into frequency bands corresponding to the odd-harmonic components of the signal, so that spectral leakage due to the

¹ Corresponding Author. Dr. Zhengmao Ye, College of Engineering, Southern University, Baton Rouge, Louisiana 70813, USA; Email: zhengmao_ye@subr.edu.

imperfect frequency response of the existing wavelet filter bank is reduced. By comparing with the harmonic group, it is shown that wavelet analysis is a potential alternative for harmonic estimation in the power systems [4]. Fractional wavelet transform has been applied to extract largest analytical information from spectral bands. Absorption spectra of the pharmaceutical samples are processed by fractional wavelet transform. The coefficients obtained can be applied to construct principal component regression and partial least squares calibrations [5]. Wavelet transform has been also implemented on biometric pattern recognition and medical diagnosis successfully. In addition, by means of soft thresholding, discrete wavelet transform can be employed for image fusion of still and moving pictures [6-8]. In subband and wavelet image coding, size-limited subband decompositions is used to limit the number of samples. To reduce coding distortions at borders, the symmetric extension filter banks are introduced in the cyclic frequency domain framework. Enhancement to the filter bank is made at a tree-structured system level. The new filter banks can implement FIR (Finite Impulse Response) and IIR (Infinite Impulse Response) filters, even with irrational transfer functions. The condensed wavelet packet transform has superior compression performance over those existing biorthogonal wavelets and block transforms [9].

A novel compression scheme has been proposed with a tunable complexity-rate-distortion as the trade-off. As the images increase in size and resolution, better compression schemes with low complexity are required on-board. Satellite mission specifications expect higher performance in terms of rate-distortion. To comply with existing on-board devices, the wavelet transform is applied in association with a linear post processing. The post transform decomposes a small block of wavelet coefficients on a particular basis. The basis can be adaptively selected by the rate-distortion optimization scheme [10]. Multiresolution synthetic aperture radar (SAR) signal processing traditionally carried out in the Fourier domain has inherent limitations in context of the image formation at hierarchical scales. A generalized approach is presented to form multiresolution SAR images using biorthogonal shift invariant discrete wavelet transform. The inherent subband decomposition of wavelet packet transform is introduced to produce multiscale filtering without any approximations. Analytical results and sample imagery of diffuse backscatter are presented to validate the efficiency [11]. A compressive sensing coding paradigm is proposed for high packet loss transmission. 2D discrete wavelet transform (DWT) is applied for sparse representation. By fully exploiting the intra-scale and inter-scale correlation of multiscale DWT, two different recovery algorithms are developed for the low-frequency subband and high-frequency subbands of the decoder. It is more robust against lossy channels, while achieving higher rate-distortion, compared with conventional wavelet-based methods and coding schemes [12]. A study of the role of wavelet packet transform in sparsity reduction is conducted in this research to enhance the compressive sensing. Quantitative results are introduced and computed in order to compare the two cases [13].

2. Discrete Wavelet Packet Transform

Most digital images are essentially sparse, with zero and nearly zero components in the matrix form. After squeezing out zero and nearly zero elements, sparse representation

of digital images are formulated. Discrete wavelet transform (DWT) has the tight affinity with compressive sensing in fields of image processing. Hence, two dimensional DWT has been proposed for data compression.

In 2D wavelet transform, the decomposition of an image matrix $f(x, y)$ of the size M by N is calculated by (1) and (2):

$$w_{\varphi}(j_0, m, n) = \frac{1}{\sqrt{MN}} \sum_{x=0}^{M-1} \sum_{y=0}^{N-1} f(x, y) \varphi_{j_0, m, n}(x, y) \quad (1)$$

$$w_{\psi}^i(j, m, n) = \frac{1}{\sqrt{MN}} \sum_{x=0}^{M-1} \sum_{y=0}^{N-1} f(x, y) \psi_{j, m, n}^i(x, y) \quad (2)$$

where the $w_{\varphi}(j_0, m, n)$ function and $w_{\psi}^i(j, m, n)$ functions are calculated which represent the approximation component, three (horizontal, vertical and diagonal) detail components, respectively for scales $j \geq j_0$; $j_0 = 0, 1, 2, \dots, J-1$ and $m, n = 0, 1, 2, \dots, 2^j - 1, N+M=2^J$; i is the directional index where $i = \{H, V, D\}$ and j_0 is starting scale. The scaling function and wavelet functions are expressed as (3) and (4).

$$\varphi_{j, m, n}(x, y) = 2^{-j/2} \varphi(2^j x - m, 2^j y - n) \quad (3)$$

$$\psi_{j, m, n}^i(x, y) = 2^{-j/2} \psi^i(2^j x - m, 2^j y - n) \quad (4)$$

Haar wavelet is chosen whose basis has been formulated as an increasing power of two of the source data set. Three-level wavelet decomposition is scheduled and the corresponding bases can be reached easily. At the level one, the data has a basis of two. At the level two, the data has a basis of four. At the level three, the data has a basis of eight, and so on for higher level decomposition. In this case, at the first level of 2D decomposition, the source digital image is decomposed into four components: approximation, horizontal detail, vertical detail and diagonal detail, each with a quarter size of the original image. The wavelets include the scaling function and three wavelet functions along with the variations in horizontal, vertical and diagonal directions, serving as the lowpass filter and highpass filters, respectively. Four resulting image matrices are computed by taking the inner products of the source image matrix with the scaling and three wavelet coefficients.

At the second and third levels, the resulting approximation is always decomposed recursively into another subset of four components (approximation, horizontal detail, vertical detail and diagonal detail). From the compressive sensing point of view, regular DWT deals with solely the approximation component while disregarding the three detail components. Its role in compression is relatively limited since no further information on the detail components can be provided. Thus, wavelet packet transform is applied to process detail components in the same way as that of the approximation component. The quaternary tree structure is thus generated, where the Haar wavelet packet transform is in charge of applying the transform to both the lowpass and the highpass components across decomposition from the level one to level three of DWT. This process can be repeated recursively to the higher levels until satisfactory results can be retrieved via inverse discrete wavelet transform (IDWT).

After decomposition, hard thresholding is introduced and applied to the detail coefficients in three orientations (horizontal, diagonal and vertical) at all levels related. These coefficients are in conjunction with the predefined thresholding function. It will then provide a smooth reconstruction process. Image reconstruction is made after two steps of three-level decomposition and thresholding. The approximation components at three levels are kept unchanged. However, the revised detail components at three levels are all subject to hard thresholding. Then the approximated $f(x, y)$ is retrieved by the inverse discrete wavelet transform as (5).

$$f(x,y) = \frac{1}{\sqrt{MN}} \sum_m \sum_n w_\varphi(j_0,m,n) \varphi_{j_0,m,n}(x,y) + \frac{1}{\sqrt{MN}} \sum_{i=H,V,D} \sum_{j=j_0}^{\infty} \sum_m \sum_n w_\psi^i(j_0,m,n) \psi_{j_0,m,n}^i(x,y) \quad (5)$$

Based on schemes of the multilevel discrete wavelet packet transform, two case studies have been conducted for compressive sensing. The lower dynamic range image is selected in the first case and the higher dynamic range image is selected in the second case, respectively. The corresponding results are described in the following section.

3. Numerical Case Studies

Two digital images in the gray level have been selected with different dynamic ranges. The first one has a relatively lower dynamic range together with fewer objects in the scene (e.g. one dolphin in the scope). The second one has a relatively higher dynamic range together with more objects in the scene (e.g. plenty of vehicles and seagulls in the scope). Two opposite examples are chosen for a comparison purpose. From Figure 1 to Figure 5, some simulation results are illustrated. The decomposition results of the lower dynamic range image are shown in Figure 1 and Figure 2, respectively, where Figure 1 depicts the wavelet packet approximations at different decomposition levels as well as the source image; and Figure 2 depicts four decomposition components at the level one exclusively. The decomposition results of the higher dynamic range image are illustrated in Figure 3 and Figure 4, respectively, where Figure 3 depicts the wavelet packet approximations at different decomposition levels and the source image, and Figure 3 depicts the four decomposition components at the level one exclusively. Figure 5 depicts the two reconstructed images using compressive sensing based on the multilevel inverse wavelet transform.

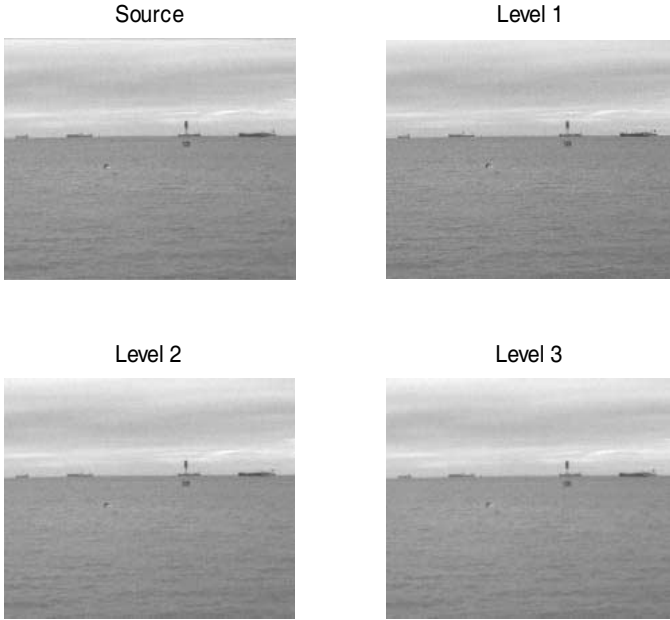

Figure 1. Wavelet Packet Approximations of Lower Dynamic Range Image

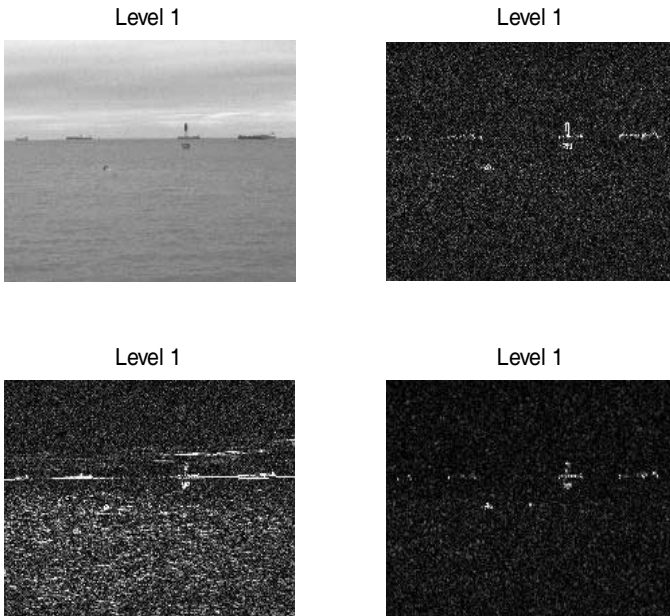

Figure 2. Decomposition at Level One of Lower Dynamic Range Image

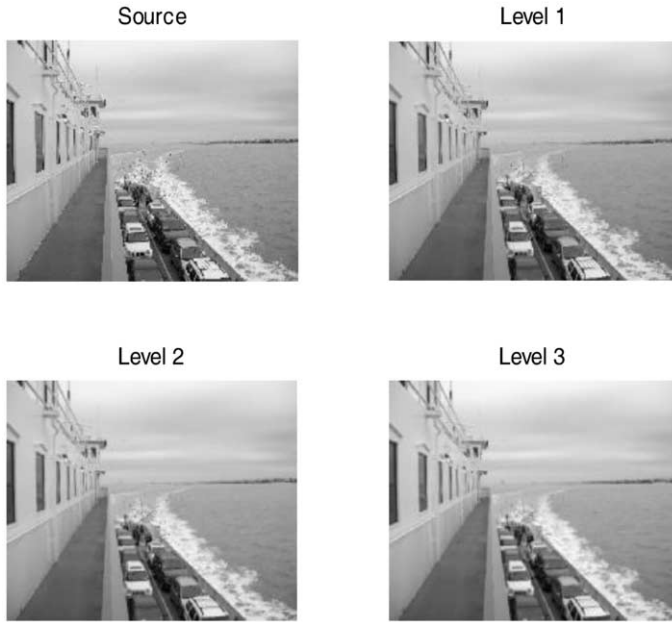

Figure 3. Wavelet Packet Approximations of Higher Dynamic Range Image

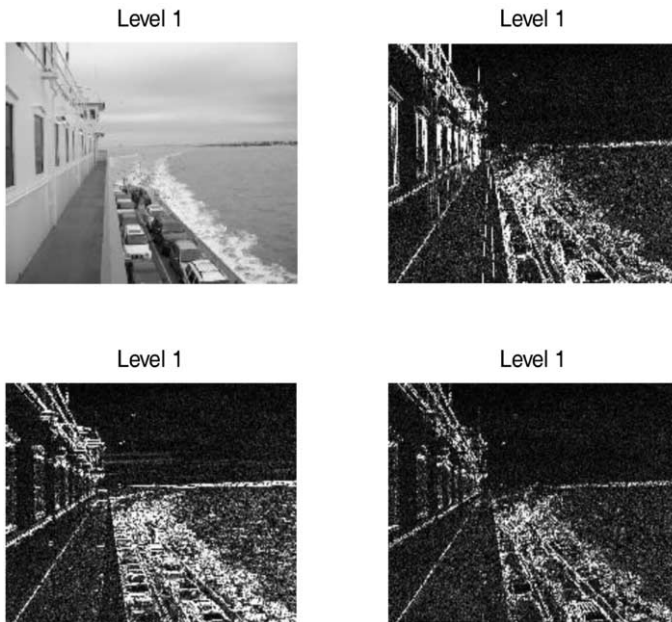

Figure 4. Decomposition at Level One of Higher Dynamic Range Image



Figure 5. Reconstruction Images after Wavelet Packet Decomposition

Comparing the reconstructed images with source images, there is almost no visual difference being observed, even though the lossy compression has been conducted in both cases. To further quantify the role of the discrete wavelet packet transform in scene image compression, define a couple of basic quantitative measures for the matter of simplicity: (1) Compression Ratio; and (2) Discrete Entropy; in order to evaluate the actual outcomes. Compression ratio is hereby defined as the ratio of the size of compressed image after reconstruction over that of the source image. On the other hand, for digital images, the occurrence of the gray level has been defined as co-occurrence matrix of relative frequencies, which is represented as the histogram. The occurrence probability distribution is thus computed based on the histogram. The discrete entropy is equal to the sum of products of the probability of the outcome times the logarithm of the inverse of probability of the outcome, with all the possible outcomes taking into account. It manifests the average uncertainty of the information source. Based on the proposed computation, the quantities are the two cases are obtained.

For the lower dynamic range image, the compression ratio is 70.07%. The discrete entropy of the source image is 6.4740 while the discrete entropy of the reconstructed image is 6.4014. For the higher dynamic range image, the compression ratio is 78.22%. The discrete entropy of the source image is 7.4105 while the discrete entropy of the reconstructed image is 7.3715. In terms of these results, it indicates that the larger compression ratio occurs along with the lower dynamic range image using multilevel wavelet packet transform. In each case, the information loss occurs using compressive sensing, since discrete entropies of reconstructed images are lower than those of source images. At the same time, lower discrete entropies are corresponding to smaller total number of the gray levels. Hence, less intrinsic information has been kept after wavelet packet transform and reconstruction. Sparsity reduction has been achieved in both cases.

4. Conclusions

Wavelet transform is powerful in image compression and restoration so as to reduce the size needed for the actual scene representation. It can also be applied to multiresolution analysis. In the special case studies for compressive sensing of two diverse sparsity level images, discrete wavelet packet transform has been introduced for multilevel

decomposition. In wavelet packet transform, a digital image has passed through both lowpass and highpass filters at each level rather than the lowpass filter itself in discrete wavelet transform, which covers more information. Thresholding is applied for better compression. As a tradeoff, representation complexity has been slightly reduced with the decrement in resolution, giving rise to lossy compression. From outcomes of two compressed digital images with the higher and lower dynamic ranges, respectively, it has been illustrated that wavelet packet transform based image compression leads to virtually no visual difference after thresholding and reconstruction. The density of the images after wavelet decomposition will be reduced in both cases. The higher compression ratio occurs in the lower dynamic range case than the higher dynamic range case. Using discrete entropy analysis, similar conclusions are made as well. The wavelet packet transform is effective in image compression while slight information loss is observed. It indicates that multilevel wavelet packet transform is fairly suitable for the general applications on the multi-dimensional compressive sensing.

References

- [1] R. Gonzalez, R. Woods, "Digital Image Processing", 3rd Edition, Prentice-Hall, 2007
- [2] R. Duda, P. Hart, D. Stork, "Pattern Classification", 2nd Edition, John Wiley & Sons, 2000
- [3] P. Fryzlewicz, "Wavelet Methods", Wiley Interdisciplinary Reviews: Computational Statistics, v 2, n 6, pp. 654-667, December 2010
- [4] J. Barros, R. Diego, "Analysis of Harmonics in Power Systems Using the Wavelet-Packet Transform", IEEE Transactions on Instrumentation and Measurement, v 57, n 1, pp. 63-69, January 2008
- [5] E. Dinc, F. Demirkaya, D. Baleanu, "New Approach for Simultaneous Spectral Analysis of A Complex Mixture Using the Fractional Wavelet Transform", Communications in Nonlinear Science and Numerical Simulation, v 15, n 4, pp. 812-818, April 2010
- [6] Z. Ye, Y. Ye, H. Yin, H. Mohamadian, "Integration of Wavelet Fusion and Adaptive Contrast Stretching for Object Recognition with Quantitative Information Assessment", International Journal on Graphics, Vision and Image Processing, ISSN 1687-398X, pp. 33-42, Vol. 8, Issue V, January 2009
- [7] Z. Ye, H. Mohamadian and Y. Ye, "Information Measures for Biometric Identification via 2D Discrete Wavelet Transform", Proceedings of 2007 IEEE International Conference on Automation Science and Engineering (CASE 2007), pp. 835-840, September 22-25, 2007, Scottsdale, Arizona, USA
- [8] Z. Ye, H. Cao, S. Iyengar and H. Mohamadian, "Medical and Biometric System Identification for Pattern Recognition and Data Fusion with Quantitative Measuring", Systems Engineering Approach to Medical Automation, Chapter Six, pp. 91-112, Artech House Publishers, ISBN 978-1-59693-164-0, October 2008
- [9] J. Lin and M. Smith, "New Perspectives and Improvements on the Symmetric Extension Filter Bank for Subband/Wavelet Image Compression", IEEE Transactions on Image Processing, v 17, n 2, pp. 177-189, February 2008
- [10] X. Delaunay, M. Chabert, V. Charvillat, G. Morin, "Satellite image Compression by Post-Transforms in the Wavelet Domain", Signal Processing, v 90, n 2, pp. 599-610, February 2010
- [11] C. Bhattacharya, and P. Mahapatra, "A Generalized Approach to Multiresolution Complex SAR Signal Processing", IEEE Transactions on Aerospace and Electronic Systems, Vol. 45, Issue 3, pp. 1089 - 1103, July 2009
- [12] C. Deng, W. Lin, B. Lee, C. Lau, "Robust Image Coding Based upon Compressive Sensing", IEEE Transactions on Multimedia, v 14, n 2, pp. 278-290, April 2012
- [13] D. MacKay, "Information Theory, Inference and Learning Algorithms", Cambridge University Press, 2003

A Complex Event Processing Based Framework for Intelligent Environments

Bilgin AVENOĞLU^{a,1} and P. Erhan EREN^a

^a*Informatics Institute, Middle East Technical University, Ankara, Turkey*

Abstract. The variety and volume of data produced by devices and sensors in Intelligent Environments (IEs) pose difficulties regarding their collection, analysis and delivery. More specifically, extraction of high level information valuable for the users requires specialized analysis techniques. In this study, we present a framework incorporating complex event processing (CEP) and publish-subscribe based messaging for addressing such needs. Within the framework, data are collected from heterogeneous data sources to go through CEP based analysis, and then the results are delivered to interested recipients. The components of the framework are loosely-coupled through the use of event driven architecture (EDA) in the form of a publish-subscribe messaging system. This enables the use of different CEP engines without requiring the modification of other components in the framework. Similarly, new data sources and delivery end-points can be as easily integrated into the framework. A real life prototype implementation is also provided for validation. The prototype includes various event producers such as electret microphone, light, temperature, motion, magnetic, optical sensors, RFID (Radio Frequency Identification) readers, smart phones, and other software systems, which are deployed in a classroom setting. End users receive relevant raw data and high level information according to their preferences, through the use of web and mobile applications. The results suggest the applicability of the framework for IEs. The prototype implementation in the classroom shows that using different event producers helps improve the analysis results and CEP is an appropriate method for data analysis in IEs.

Keywords. Intelligent environments; complex event processing; multi-modal sensors; event-driven architecture; publish-subscribe

Introduction

Advances in wireless networking and sensor technologies together with the miniaturization and reduction in power consumption of connected devices have facilitated the proliferation of IEs [1]. Deployment of these new technologies in real-life environments allows people to receive data about physical objects and conditions. Furthermore, the collection of such data enables situation awareness through the use of various analysis techniques.

Typically, high level information cannot be directly measured through the use of existing sensors; hence they need to be extracted by analyzing and combining low-level data from available sensors. While occasionally people are interested in only the low level data collected by sensors in an IE, in most cases the utility provided increases with the level of information. However, the sheer volume of the data is significant and

¹ Corresponding Author E-mail: bavenoglu@gmail.com

may hinder the extraction of valuable high level information, which calls for specialized solutions. In addition, heterogeneity of end-points in the environment causes additional complications.

To this effect, we present a framework allowing the collection of data from a set of multi-modal sensors, and the delivery of low-level data as well as high level information extracted through the utilization of the CEP approach. The components of the framework are tied together by using EDA in the form of a publish-subscribe based messaging system, enabling loose-coupling of system modules and heterogeneous end-points for data collection and information delivery purposes.

CEP is an event processing concept [2] dealing with multiple events under multiple logical conditions [3]. CEP can continuously process high-volume and high-speed data and deliver actionable information [4]. Its importance and applicability have been demonstrated in several application areas, including logistics, energy management, finance, and manufacturing processes [5], for the purposes of anomaly detection and extraction of high level information. Considering the requirements of IEs with a set of heterogeneous sensors generating a large volume of data, we have a similar need, and CEP appears as a preferable solution. As such, we intend to use CEP for extracting information according to different preferences and needs of users in an IE.

Collecting data from a set of multi-modal sensors and delivery of extracted information to heterogeneous end-points require a mechanism for establishing connections among them. In this context, EDA is a preferred approach, since it enables loose coupling among involved components by the employment of publish-subscribe type communication, where publishers and subscribers are unaware of each other [6]. In an IE, all interested parties, including data analysis modules, web applications, and mobile applications can subscribe to sensor events. As a result, they receive raw data or high-level information through the messaging system to be presented to users as customized deliveries according to their interests.

In addition to the conceptual design of the proposed framework, we also provide a real prototype implementation in order to evaluate the applicability of our approach. For this purpose, a classroom is chosen as the testbed environment, where different sensor modalities are deployed for data collection. Similarly, different end-points in the form of mobile and web applications are provided for users associated with the classroom. In addition, two different CEP engines are integrated for assessing their operations in a real setting, and demonstrating the modularity of the framework. While it is not intended to be a comprehensive evaluation, we present our findings in order to highlight the utility provided by the framework for IEs. In conjunction with this prototype, we also intend to demonstrate the benefit provided by the use of multi-modal sensors regarding the extraction of high level information.

In the remainder of the paper, Section 1 contains the background and selected studies related to designing and deploying IEs. In Section 2 we give the details of the conceptual architecture of the framework and discuss the building blocks used. Section 3 explains how we implement the prototype of the framework in a classroom. In Section 4 we evaluate the framework based on the collected data on this prototype. And, finally, Section 5 provides the conclusion.

1. Background

IEs have been the issue of active research in recent years. Research studies in this field have addressed issues regarding different environments such as hospitals/nursing rooms [4] [7], homes/rooms [8] [9] [10], cities (streets, bus stations) [11] and classrooms [12]. Besides this, various analysis methods have been utilized, including CEP [4] [13], semantic reasoning [9] and machine learning [10].

CEP is an approach used successfully in logistics, finance and business planning domains [14]. There are many success stories about using CEP, such as for improving operational efficiency in production line of a semiconductor producing company [15], enabling a telecommunication company to offer their customers real-time situation-based promotions [16], and detecting trade market abuses for an authority organization on financial services [17].

Using CEP for analyzing data in IEs is a fairly new concept. In [4], authors conduct a research in an RFID-enabled hospital for patient identification and monitoring, asset tracking, and patient-drug compliance. This study is mainly based on RFID sensor data, and their management for surgical procedures. Data are analyzed by the Drools CEP engine [2]. On the other hand, our study includes many different sensor types including smart phone sensors. Moreover, we use a messaging middleware for loosely coupled integration of components and sending push messages to user-level applications. We also test our framework in a classroom environment with two different CEP rule engines which emphasize the modularity of the framework.

In [10], authors design an intelligent room for human behavior detection and activity support. They use different sensors such as magnet sensors, micro-switches and RF-tags, attached to objects in the room. The goal is to detect humans' intentions and give them ambient sounds such as playing classical music according to identified intentions. They use ID4 learning algorithm off-line with test subjects for determining the rules. They generate rule sets by a programming language. Even though writing rule sets with a programming language can be enough for the intentions that they determine, CEP-based rule engines perform better when the number of rule sets and the amount of events produced are large. Moreover, the system collects data from RS-232c connector and Java-based software analyses the collected data and present data to graphic interface. One of the shortcomings is that there is no interface for end users to get sensor data from the system and the only interaction methods are voice messages and playing music. In order to provide flexibility in our proposed framework, we incorporate a messaging system allowing flexible messaging exchange among different entities in the environment.

Killeen et. al. [8], develop a smart home system for home security. The hardware used in this home is similar to the hardware we use in our study. They use RFID reader, infrared sensors, XBee radios, Arduino cellular module, web interface, temperature sensor, smoke/CO detector, buzzer, voice recorder, security camera, and a stepper motor. These are deployed as sensor nodes allowing a homeowner to monitor his home. All nodes communicate wirelessly with the base station, which includes an 8051 microcontroller, an Arduino board, a cellular shield and an Ethernet shield. The base station gets the messages and takes actions such as triggering an alarm and sending text messages. The rules for taking an action appear to be embedded in the microcontroller. For this reason adding a new sensor to the room or a new RFID tag to the system requires the reprogramming of the microcontroller. The Arduino board has a small web server with a page showing status information related to the sensor nodes and users can

access this page with a web browser. Also a browser-based Android application shows the web page from this web server. These applications refresh the page by pulling data from the web server. Compared to that study, our proposed framework is more flexible due to the capability of adding new sensors and new rules easily by writing few lines of code without the need of hardware reprogramming. Moreover, our system sends push-based messages when an event or a complex event occurs, and users can change the subscriptions according to their preferences.

2. Architecture

2.1. Framework Architecture

The proposed framework includes four main components. Figure 1 shows these components and the overall conceptual architecture. This framework allows different event producers to publish data. As such, sensors in the environment, users' smart phones, and other software systems publish messages to the messaging system, which are then collected by the data analysis component for high level information extraction. Subscribers such as high-level user applications or the CEP engine get the results of this data analysis, and consume them according to their requirements.

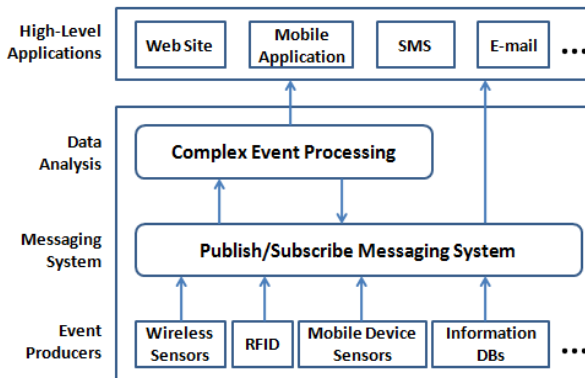

Figure 1. Conceptual Architecture

2.2. Event Producers

The framework incorporates different types and numbers of event producers such as sensors with wireless communication capabilities embedded into the environment, including RFID sensors, users' mobile phones or other information databases. Collecting events from various types of event producers helps increase the accuracy of the inferences. The only requirement for being an event producer is to be able to publish data to the topics in the messaging system by using the Java Message Service (JMS) API or RESTful services.

The event producers can send messages in different formats. For example, a context modeling approach such as key-value model, markup scheme models or ontology-based models are possible alternatives. In this framework, we use the key-value modeling approach because it is easy to manage key-value pairs [18].

2.3. Messaging System

The proposed framework is designed to support EDA, where the main benefit is loose coupling of components [6]. Loose coupling is important because there may be potentially many entities exchanging data and they may not be present at the same time [19]. Generally, a component publishes events and other components listen to these events, but they are unaware of each other [6]. Traditional request/response paradigm uses “pull-based” approach which requires listeners or clients to poll the server periodically [19], which results in the overloading of the server. In EDA, publish/subscribe paradigm is used incorporating a “push-based” approach which helps send messages as soon as they are available. In the proposed framework event producers send the messages immediately and the other interested parties such as CEP engine and mobile applications receive them asynchronously. Event producers are not aware of the parties receiving their messages.

2.4. Data Analysis

Different techniques are available for data analysis in IEs such as machine learning methods [10] and semantic rule-based systems [9]. In the proposed architecture we use the CEP approach. CEP deals with evaluating many correlated events and then taking an action [20]. CEP processes events for detecting meaningful events by using techniques such as detecting event patterns within many events, event correlation and event hierarchies. Moreover, CEP tries to find the relationships between events such as causality, membership and timing [21].

There can be different types of event producers generating data at different scales in IEs. Moreover, these event producers can produce a large amount of data, such as an electret microphone sensor. CEP can continuously process high-volume and high-speed data [4] [22] [23]. Besides this, performance of CEP engines has another advantage. CEP engines deal with the events within these large numbers of events only if there are rule statements related to these events in the engine, otherwise they discard the unrelated events.

2.5. High-Level User Applications

One of the purposes of the proposed framework is to infer high-level information from the raw data coming from different event producers and present them to the users according to their requirements. Users can subscribe to topics carrying raw data and high-level information in the messaging system, by using different application software such as web or smart phone applications. The framework can send messages to users at nearly runtime using push-based messaging. Users can select the topics they are interested in and subscribe to them. They can also remove their subscriptions whenever they want.

3. Implementation

In order to assess the applicability of the proposed framework, we develop a prototype in a classroom [24]. One of the goals is to extract high-level information from the sensors embedded in the classroom, such as “lecture started”, “break given”, “break ended”, “lecture ended”, “the lights are left open” and “the classroom is too cold”. Different users associated with the classroom utilize such information. Students can receive information about the status of the lecture. For example, if a student is late, he

can get information about the lecture (whether the lecture is started or delayed), while he is on his way. Similarly, administrative personnel can track the status of the classroom. If there is noise in the classroom after locking the door, they can be informed that the air-conditioner is left open or a sleepy cat is stuck in the classroom. Moreover, lecturers can get information from the framework such as how many students are in the classroom and what the room temperature is.

As part of the prototype deployment, in order to determine the events in the classroom, required sensors for these events and high-level useful information, we examine the daily events associated with the classroom. The daily schedule typically includes the following activities: 1) Administrative personnel unlocks the door of the classroom in the morning, 2) Students enter the classroom for attending a lecture, 3) Lecturer enters the classroom and the lecture starts, 4) Several breaks may be given during the lecture, 5) The lecture ends, the lecturer and the students leave the classroom, 6) For each lecture throughout the day, the above steps are repeated, 7) If there are no more lectures, administrative personnel checks the classroom and locks the doors. Even though these are the typical activities, there may be different situations throughout the day. A lecture may start late and may be extended or cancelled. The administrative personnel may forget opening or locking the door. Besides these activities, some automated decisions related to the classroom can be made. For example, to provide necessary lighting conditions, automated light and curtain control can be utilized.

Based on these observations we provide a prototype implementation of the proposed framework (Figure 2).

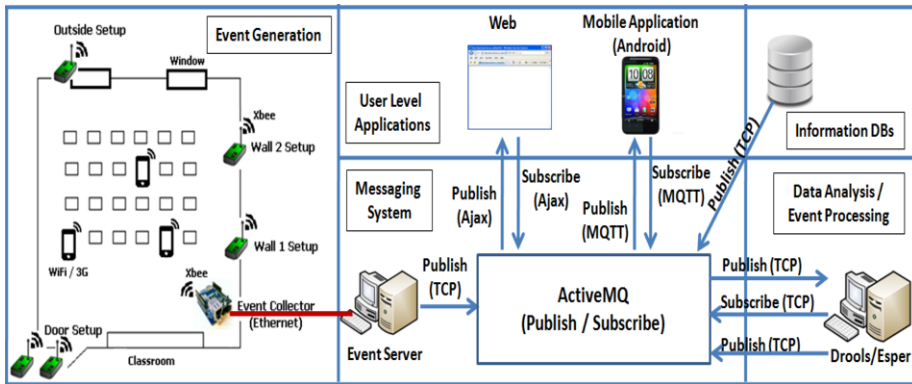

Figure 2. Prototype Framework Implementation.

3.1. Event Producers

We use different event producers in the classroom. Sensors in the classroom, students' smart phones and schedule information from a database are selected as the event producers. The sensors in the classroom and the events generated by these sensors are listed in Table 1. According to Figure 2 the following sensor sets are deployed: a) Wall 1 Setup: Electret Microphone, Light, Temperature; b) Wall 2 Setup: Motion, Light; c) Outside Setup: Light, Temperature; d) Door Setup: Infrared (two), Motion, Phototransistor (two), Hall Effect, RFID; e) Smart Phones: Accelerometer.

These sensor sets transmit messages to the collector node in the classroom with the help of XBee wireless modules supporting the IEEE 802.15.4 network protocol. Then, the collector node, which is connected to the LAN through Ethernet, sends these

messages by using TCP/IP to a server listening to them on a socket. The server then parses the messages and sends them to the appropriate topics in the messaging system.

We also develop an Android application to be used as an event producer, which gets accelerometer data from the phone and sends them to a topic in the messaging system through the REST interface. Student phones are required to connect to the internet by Wi-Fi or 3G. The Android application sends the accelerometer data only when it detects the movement of its user, hence reducing the number of messages.

The events required from other software systems such as lecture start and end times are recorded in a schedule database. A task scheduled in the Windows Task Scheduler runs a Java program every 15th, 30th, 39th and 40th of an hour. This program sends messages to a topic in the messaging system: “1 Minute Before The Lecture”, “Last Lecture”, “Lecture Start Time”, “15 Minutes Left Before The End of The Lecture”, and “Lecture End Time”.

Table 1. Sensors, Events and Values

Event Detected	Sensor Used	Value
Door state - Open/Closed	Hall Effect Sensor and Magnets on door.	0:Closed 1: Open
Door state - Open/Closed	Phototransistor	0:Closed 1: Open
Door state - Locked / Unlocked	Optical Detector(Phototransistor) inside the lock to sense door lock.	0:Unlocked 1:Locked
People passing through the door	Infrared proximity sensor in door threshold	1:Object Exists (5-150 cm)
People ID's	RFID Reader	16 Digit String
Ambient Temperature	Temperature Sensor inside/outside of the room	°C
Ambient Light Intensity	Photoresistor inside and outside of the room	0:Dark 1:Light
Noise level in the classroom	Electret Microphone inside the classroom	0:Silence 1:Noisy
Motion in the classroom	PIR Motion sensor in the classroom	1:Motion
Motion of the Students	Accelerometer sensor on the mobile phones	+2g , -2g

3.2. Messaging System

We use the Apache ActiveMQ open source messaging server as the publish-subscribe based JMS messaging system. Even though JMS supports sending and getting messages by using Java, ActiveMQ adds additional features such as guaranteed delivery, high availability, high performance and scalability. Besides this, ActiveMQ supports Ajax “which is an Asynchronous JavaScript and Xml mechanism for real time web applications” and Message Queuing Telemetry Transport (MQTT) which is a “machine-to-machine publish/subscribe messaging transport”. These two properties allow ActiveMQ to send messages as push-based to the recipient web and smart phone applications. All event producers have corresponding topics created beforehand in ActiveMQ and they publish messages to these topics as soon as an event occurs. A message includes a sensor measurement and an ID distinctly identifying the sensor.

3.3. Data Analysis

We use two different CEP enabled rule engines for data analysis: Drools and Esper. The reason for using two different rule engines is to demonstrate that the architecture enables the replacement of one engine with another one easily, without modifying other components, hence highlighting the advantage of using EDA. In addition, the ease of expressing complex rules in different languages is shown.

We identify the complex events deemed to be important for students and lecturers. Table 2 shows these complex events and the rules used to compose them. We

implement these complex rules in both the Drools and Esper languages. Figure 3 shows a sample code which represents the “Lecture Started” complex event in both the Drools and Esper languages. Both of these codes check the time of the lecture (whether it has passed), the door status (whether it is closed), the number of students in the classroom (there should be more than 6 students), and the location of the lecturer (whether he is in the classroom), for the “Lecture Started” complex event. When the event is detected, a message is sent to a topic in ActiveMQ, which end user applications can receive from. After detection, this complex event is also inserted into the CEP engine and other events which are “Break Ended” and “Lecture Ended” are retracted from the engine.

Different types of sensors and different rule sets can be used for inferring the same complex event. For example, while a rule set includes the electret sensor for the “Lecture Started” complex event, another rule set uses the light sensor instead. Because, both the noise level in the classroom, and light sensor near the blackboard denoting that the projector is running, provide clues about the “Lecture Started” complex event.

Besides complex events, we also compose some decision rules that can be automatically handled by actuators in the classroom. We currently do not implement the actuators but only write the rules in both Drools and Esper languages and the system sends messages when these events occur. These rules are listed in Table 3.

Table 2. Rules for Extracting High-level Information [24]

Code	Complex Event	Rules
CE-1	Lecture will be delayed	- Are most of the (30%) students in the classroom? - Is the inside temperature over 17°C - Is the door still locked when there is 1 minute left for lecture start time?
CE-2	Lecture Started	- Lecture start time has passed - Instructor is in the classroom - Most of the students are in the classroom (60%) - The door is closed
CE-3	Late Entrance	-Lecture starts -The door opens - IR and motion sensors detect activity
CE-4	Break given	- 30 to 90 minutes passed since the lecture started - OR 30-90 minutes passed since the last break - Door is open - People passing through the door - Phones send activity data.
CE-5	Break ended	- 5 to 30 minutes passed since the break. - Door is closed. - Phones do not send activity data.
CE-6	Lecture ended	- Less than 15 minutes remain for the lecture end or end time is passed - Door is open - People passing through the door - Instructor leaves the classroom - Most of the students leave the classroom (less than 30% remain)
CE-7	Lecture finished early	- Door is open - People passing through the door - More than 15 minutes remain before lecture finish time - Instructor leaves the classroom - Most of the students leave the classroom (less than 30% remain)
CE-8	Classroom check	- CE7 is deduced - The door is locked - The noise level is low after the door is locked. - There is no motion in classroom after the door is locked. - The light intensity is low in classroom.

Table 3. Automation Rules [24]

Code	Complex Event	Rules
AR-1	Open the curtains	- Photoresistor values are low in the classroom - Photoresistor values are high outside
AR-2	Turn on the lights	- Photoresistor values are low both in the classroom and outside
AR-3	Open the window	- Temperature values are high in the classroom - Outside temperature is lower, but above 19°C outside
AR-4	Run air conditioner	- Temperature values are high both in the classroom and outside

<pre> **** DROOLS **** Rule "LectureStarted" WHEN not(DroolsEvent(event == "LectureStarted") from entry-point DEFAULT) \$eventA: SensorEvent(sensorName=="Hall0") over window:length(1) from entry-point classroom SensorEvent(data == 1) from SevenA \$state: currentState(numberOfStudents >= 6, timeOfLecture == "ST", isInstructorThere == true) from entry-point DEFAULT THEN Main.sendToJMS("DROOLS:Lecture Started"); Main.addEventLectureStarted(); Main.retractEventBreakEnded(); Main.retractEventLectureEnded(); End </pre>	<pre> **** ESPER **** EsperCEPProvider.AddRule("SELECT * FROM pattern[every RFIDEvent -> SensorEvent] * WHERE ((SELECT COUNT(*) as DoorCloseEventNum * FROM SensorEvent(sensorName = 'Hall0', data = 1).win:length(1) = 1) * AND ((SELECT COUNT(*) * FROM EsperEvent(event='LectureStarted', eventValid=true).win:length(1)) != 1) * AND currentState_numberOfStudents >= 6 * AND currentState_timeOfLecture = 'ST' * AND currentState_isInstructorThere = true", New EsperCEPEventListener(RuleEnum.LECTURE_STARTED)); ----- Case LECTURE_STARTED: Main.sendToJMS("ESPER:Lecture Started"); EsperCEPProvider.addEventLectureStarted(); EsperCEPProvider.retractEventBreakEnded(); EsperCEPProvider.retractEventLectureEnded(); Break; </pre>
---	--

Figure 3. Rules for "Lecture Started" Complex Event in Drools and Esper Language

3.4. High-Level User Applications

One of the goals of this framework is to deliver information to users based on the collected and analyzed data. Therefore, we develop two different software applications for displaying push messages to users when events occur. The first one is an Ajax-based web application, and the second one is a smart phone application supporting MQTT. Students receive messages by using these software tools as soon as the rules for complex events are fired by the generated events in the environment.

Users can subscribe not only to topics where sensors send raw data, but also to high-level information messages produced by the CEP engine. For example, a user can simultaneously subscribe to both the temperature sensor topic for getting raw temperature data and the 'Lecture Delayed' complex event in order to receive this information when he is late. Also, new complex events can be created easily according to user requirements and preferences.

4. Evaluation

We evaluate the framework by examining the data collected from event producers. Figure 4 shows the data volume collected from event producers during a standard lecture which generally lasts 3 hours. Since the electret sensor produces a high number of events, we divide the total number of electret events by 4 for increasing the quality of the graphic. The door optic sensor, and the motion sensor located in the "Wall 2 Setup" as well as the phone accelerometer sensor also produce a large number of events compared to other sensors.

We also examine the data collected from the door optic sensor, electret sensor, motion sensors and infrared sensors. Figure 5 shows this comparison, denoting a lecture period between 14:30:00 and 14:39:33, a break period between 14:39:33 and 14:54:45, and again a lecture period between 14:54:45 and 15:04:26. In this figure "DoorOptic" shows the phototransistor sensor result located in the "Door Setup". This sensor produces "1" when the door is closed, and "0" when opened. We replace these numbers by 600 and 500 in the figure, respectively, for increasing the quality of the graphic. The electret sensor is located in the "Wall 1 Setup". There are two motion sensors in the classroom, "Motion0" in the "Door Setup" and "Motion1" in the "Wall 2 Setup". "Motion0" mostly detects motion when there is a break and students are walking in the classroom. This sensor also detects the motion of the lecturer during the lecture when he comes close to the door. "Motion1" is located on a wall in the middle of the classroom for detecting the students' movements. However, it detects high motion even during the lecture because students are not stationary even when they are

sitting. “Infrared0” and “Infrared1” sensors are located in the “Door Setup”. These sensors show whether the students go through the door. We use two infrared sensors because we need to understand whether a student is entering or leaving the classroom.

We propose that using multi-modal sensor analysis increase the probability of the correct inferences, and Figure 5 supports this claim. In Figure 5, the results from the electret sensor show that there is less noise in the classroom during the break. However, this is not always the case. Sometimes, many students may be talking during the break which in turn results in increased noise level. In Figure 5 this situation is visible between the times 14:45:18 and 14:47:24. For this reason, electret sensor cannot be used solely to detect a break. The door optic sensor clearly indicates the break in this case because it produces distinct values such as 0 and 1. However, sometimes students or lecturers leave the door ajar accidentally or intentionally for ventilation. Similarly, infrared sensors also cannot be the only indicator for a break. Some students can be late and they enter the classroom after the lecture started. These late entrances trigger the infrared sensors. Hence, if we examine many of these sensors together we can detect events with more accuracy. In Figure 5, the combination of the door optic sensor and two infrared sensors exactly identify the break. On the other hand, the electret sensor and the motion sensor in the “Door Setup” provide hints about the break. Besides this, the schedule information also helps detect these events. For example, a lecture generally starts at the 40th minute of an hour and a break is given at 30th minute of the next hour. These times can change according to the lecturer, and the schedule information also cannot be the sole indicator but helps obtain more accurate result.

We can also use the data collected from students’ smart phones for making inferences. Figure 6 shows the accelerometer data from a student’s smart phone. The time interval corresponds to the same time interval as Figure 5. This figure shows that the student stands up when the break is given and carries out some activities such as walking. Probably, he sits down twice for short periods of time, between 14:46 and 14:47 and between 14:48 and 14:49. Not all students behave the same, and some students prefer to spend the breaks sitting. However, the data collected from several students in the lecture help determine the break start and end times.

We count the number of detected complex events for a 3-hours lecture. The framework is able to detect one CE-2, one CE-6, two CE-4, two CE-5, one AR-5, and five CE-3 complex events throughout the lecture.

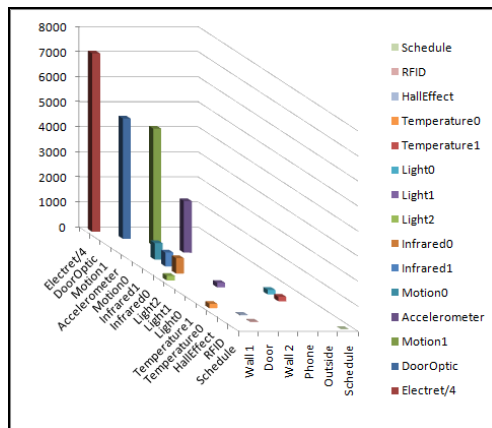

Figure 4. Volume of Data Collected from Event Producers

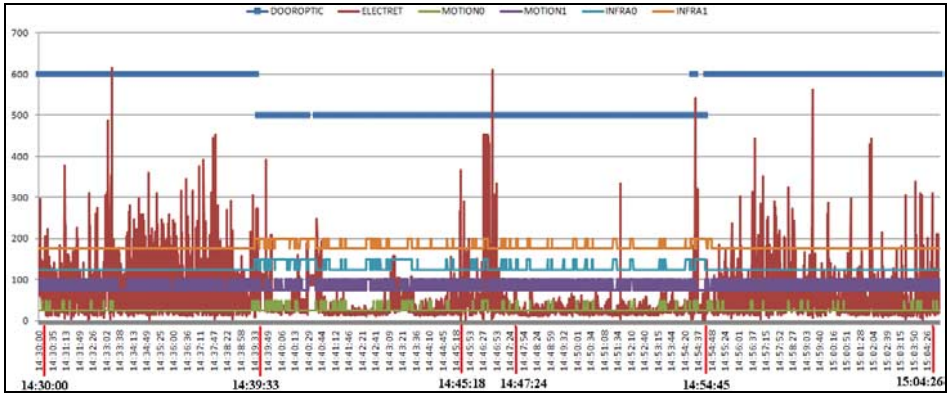

Figure 5. Comparison of Different Sensors for Detecting a Lecture Break

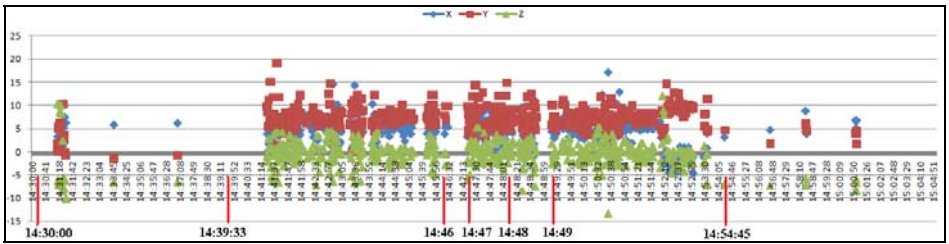

Figure 6. Accelerometer Data from a Smart Phone of a Student

5. Conclusion

In this study, we propose a framework for IEs, utilizing CEP based analysis and publish-subscribe messaging approach, in order to enable the collection of data from heterogeneous data sources as well as the delivery of extracted information to interested recipients. The framework supports collecting data from wireless sensors, smart phones and other information databases. The data produced by these devices are converted into events and EDA is used with publish-subscribe based messaging system enabling flexible messaging and modularity. The CEP-based data analysis component is used for extraction of high-level information from high-variety, high-volume and high speed data produced by the event producers. End user applications receive information as soon as the events occur, and users have the option of selecting the events they are interested in.

In addition, we provide a prototype implementation of this framework in a classroom environment, where complex events such as “Lecture Started” and “Break Given” are extracted. Results show that different types of sensors produce a large amount of data; hence CEP is an appropriate method for the analysis. In addition, the data collected in the experiments suggest that using different sensor modalities may help increase the accuracy of inferences. Implementing the framework in a classroom environment validates the applicability of the framework.

As future work, we plan to increase the number of experiments as well as the types and numbers of event producers in order to extend the analysis. In addition, we intend to deploy and test the prototype in environments other than the classroom setting.

References

- [1] D. Monekosso, P. Remagnino, and Y. Kuno, Eds., *Intelligent Environments*. Springer London, 2009.
- [2] The JBoss Drools Team, “Drools Fusion User Guide.” [Online]. Available: http://docs.jboss.org/drools/release/5.5.0.Final/drools-fusion-docs/html_single/index.html. [Accessed: 24-Feb-2013].
- [3] H. Taylor, A. Yochem, L. Phillips, and F. Martinez, *Event-Driven Architecture: How SOA Enables the Real-Time Enterprise*, 1st ed. Addison-Wesley Professional, 2009.
- [4] W. Yao, C.-H. Chu, and Z. Li, “Leveraging complex event processing for smart hospitals using RFID,” *Journal of Network and Computer Applications*, vol. 34, no. 3, pp. 799–810, 2010.
- [5] A. Buchmann and B. Koldehofe, “Complex Event Processing,” *it - Information Technology*, vol. 51, no. 5, pp. 241–242, Sep. 2009.
- [6] M. Bali, *Drools JBoss Rules 5.0 Developer’s Guide*. Packt Publishing, 2009.
- [7] T. Hori, Y. Nishida, and S. Murakami, “Pervasive sensor system for evidence-based nursing care support,” in *Proc. 2006 IEEE International Conf on Robotics and Automation.*, pp. 1680–1685.
- [8] P. Killeen, J. Monkus, E. Klessig, D. Hearn, J. Wu, and S. C. Smith, “Developing a Smart Home System,” in *International Conference on Embedded Systems and Applications*, 2011, pp. 148–152.
- [9] D. Bonino and F. Corno, “Rule-based intelligence for domotic environments,” *Automation in Construction*, vol. 19, no. 2, pp. 183–196, 2010.
- [10] Y. Nakauchi, K. Noguchi, P. Somwong, T. Matsubara, and A. Namatame, *Vivid room: human intention detection and activity support environment for ubiquitous autonomy*, vol. 2. Ieee, 2003, pp. 906–911.
- [11] F. Gil-Castineira, E. Costa-Montenegro, F. Gonzalez-Castano, C. López-Bravo, T. Ojala, and R. Bose, “Experiences inside the Ubiquitous Oulu Smart City,” *Computer*, vol. 44, no. 6, pp. 48–55, Jun. 2011.
- [12] M. Srivastava, R. Muntz, and M. Potkonjak, “Smart kindergarten,” in *Proceedings of the 7th annual international conference on Mobile computing and networking - MobiCom '01*, 2001, pp. 132–138.
- [13] D. Romero, G. Hermosillo, A. Taherkordi, R. Nzekwa, R. Rouvoy, and F. Eliassen, “RESTful integration of heterogeneous devices in pervasive environments,” in *Proceedings of the 10th IFIP WG 6.1 international conference on Distributed Applications and Interoperable Systems*, 2010, pp. 1–14.
- [14] R. von Ammon, C. Emmersberger, T. Greiner, F. Springer, and C. Wolff, “Event-Driven Business Process Management.” 28-Sep-2008.
- [15] P. VINCENT, “TUCON2011: STMicroelectronics and optimising manufacturing,” 2011. [Online]. Available: <http://www.thetibcoblog.com/2011/10/03/tucon2011-stmicroelectronics-and-optimising-manufacturing/>. [Accessed: 04-Mar-2013].
- [16] “Turkcell Launches Real-Time, Situation-Based Marketing Enabled by Progress Software,” 2011. [Online]. Available: <http://www.bloomberg.com/apps/news?pid=newsarchive&sid=a03HTx2Fwb.8>. [Accessed: 04-Mar-2013].
- [17] “FSA (Financial Services Authority) to Use Progress Apama to Power Real Time Market Surveillance and Market Abuse Detection System,” 2007. [Online]. Available: <http://www.progress.com/en/inthenews/fsa-financial-servi-6192007.html>. [Accessed: 04-Mar-2013].
- [18] T. Strang and C. Linnhoff-Popien, “A Context Modeling Survey,” *Graphical Models*, vol. Workshop o, no. 4, pp. 1–8, 2004.
- [19] G. Cugola and H. A. Jacobsen, “Using publish/subscribe middleware for mobile systems,” *ACM SIGMOBILE Mobile Computing and Communications Review*, vol. 6, no. 4, pp. 25–33, 2002.
- [20] B. M. Michelson, “Event-Driven Architecture Overview,” *Architecture*, p. 8, 2006.
- [21] Wikipedia, “Complex event processing.” [Online]. Available: http://en.wikipedia.org/wiki/Complex_event_processing. [Accessed: 01-Mar-2013].
- [22] Esper Team and EsperTech Inc., “Esper Performance-Related Information.” [Online]. Available: <http://esper.codehaus.org/esper/performance/performance.html>. [Accessed: 01-Mar-2013].
- [23] An Oracle White Paper, “Oracle Complex Event Processing Performance,” 2008.
- [24] M. Ö. Kaya, “A complex event processing framework implementation using heterogeneous devices in smart environments,” Middle East Technical University, 2012.

Synergetic Tropisms: A case study for a multi-performative design concept

Efthymia KASIMATI, Eleanna PANAGOULIA

*School of Architecture, Faculty of Engineering, Aristotle University of Thessaloniki
Thessaloniki, Greece*

Abstract. This paper proposes a framework for an integrated, computational design system, by the agency of interdisciplinarity. The proposed design concept is approached through the formation of a holistically structured unit that is organized as an information processing brain. Considering the before-mentioned aspect about interdisciplinarity, the paper will analyze a multi-performative organization, examining networked intelligence and the role of semi-autonomous systems in design. We demonstrate a design method that addresses a multi-disciplinary problem and integrates generative synthesis mechanisms and tools, in order to formulate an effective computational system. The design concept further investigates the correlation between these concepts to architecture and, hence, materiality and structure. In order to examine the implementation of these terms in architecture, we model a case study for a generative mechanism that enacts as open research. It addresses multi-performativity and complexity by performing various functions, such as task recognition and context-aware applications. A distributed system is employed, in which discrete mechanisms assemble a data flow network. This interaction network defines an intelligent mechanism, which is further examined as a design tool. The present paper brings about design technologies that integrate methods of computer-aided architecture; therefore our case study outlines techniques and applications of machine intelligence. Henceforth, it provides the unique chance to converge multiple disciplines that exchange information at all levels, from the analogue to digital and material realm.

Keywords. Complexity, adaptation, multi-performativity, interdisciplinarity

1. Introduction

Contemporary architecture is witnessing the emergence of distancing from deterministic schemas in design methods towards more complex scenarios. This implies design problems that cannot be solved by a linear chain of reasoning- derived, consecutive procedures. This shift requires the development of new ways to represent design methods and to address their different disciplines performance collectively.

This paper proposes a framework for an integrated, computational design system, implemented in the architectural realm. Interdisciplinarity is employed as a design strategy that organizes the information flow inwards a system. It is approached by the formation of a holistically structured unit that is organized as an information processing brain. This systematic approach is placed in the field of research by design, as it is about continuous reprogramming and reconsideration. The main objective of this framework is the construction of a system that gathers several attributes of artificial intelligence. It is built on the strengths of adaptive behavioral systems and context

awareness, in order to form a mechanism that processes information within a context. Adaptability and context-aware applications are used to build smart environments and conceive networked intelligence through information processing systems.

The articulation of the framework is demonstrated through a case study of a fictional example. Through this paper we will analyze a case of a multi-performative design method, examining the role of semi-autonomous systems in design, and holistic approaches in computational interdisciplinary systems. This entails the synthesis of a decision-making system that allows parallel processing of information. We address an intelligent systematic approach that forms an open-ended system, where discrete disciplines create networks of interaction that can self-organize, be shaped and driven by the intelligence of every discipline involved.

1.1. Case study

The implementation of these terms in architecture is examined through our case study for a generative mechanism that enacts as open research. It addresses multi-performativity and complexity by performing various functions, allying with the engagement of complex phenomena. The before mentioned interaction network articulates our design method, regarding a design process in terms of its being conducted by an intelligent mechanism. This mechanism is examined as a design tool, along a way to explore beyond pre-reminded representations, further integrated in a physical environment. Therefore, our case study outlines techniques and applications of machine intelligence. Our main objective is to depict a design method that addresses a multi-disciplinary problem and integrates generative synthesis mechanisms and tools, in order to formulate an effective computational design system.

1.2. Context dependency

Our process focuses in conceiving a design framework that entails a multi-performance, context-dependency case about a structural habitable organism. The proposed framework facilitates a performative bio-structure that incorporates self-reconfigurability and symbiotic performance. This case study outlines an attempt to examine the synergetic relationship between the architectural object and its environment, integrating various performance criteria, such as circumstantial, technological, social and environmental aspects. We form an integrative behavior-based process, which develops dynamic architectural systems, interrelated in their material, spatial, and environmental nature. We rather refer to artificial habitable ecosystems capable of intelligent responses than of computer-controlled conventional housing. This design process is giving the environment the ability to design itself, to be knowledgeable, and to have to autogenic existence. Thus, context dependency means that all principals are qualified by the context that acts as an operator to assign meaning to the metaphorical signals produced by the mechanisms. Context is defined here as any information that can be used to characterize the situation of an entity. The interactive process between the structure and its environment refers to context awareness, in a way that the structure both '*senses*' and '*reacts*' based on its environment. By means of the responsive ecosystem, the environment takes an active role, initiating to great or small degree changes as a result of various computations.

Hence, intelligence is an essential attribute of such systematic approaches, as it contributes to the system's adaptation to ever-changing contextual conditions. It is

based on a system's capacity to respond to the uncertain character of a construction context and to variable human needs. It adapts to sudden changes that invalidate the current model, therefore, we infer that the articulation adapts in an intelligent way, by continuous re-evaluation of its contextual interrelations. The proposed method, as it will be argued, employs a generative mechanism that shares the same or higher complexity level with its environment, in order for it to adapt. We work out adaptive scenarios that accept unpredictability and uncertainty, as operating modes and base on open-ended systems, porous to a number of real-time inputs.

2. Generative mechanism

At this point, our research should provide for a generative mechanism in order to express the difference and complexity of the proposed system. We refer to the formation of an integrative behavior-based process, which develops dynamic architectural systems, interrelated in their material, spatial, and environmental nature. In order to construct this generative system, we conscript a common approach in all interrelated fields that articulate our system. This approach calls for generic strategies that structure a flexible system, therefore, every agency correlated to our approach, shares same generic patterns in order to form coherent, synergetic relationships, in terms of interdisciplinarity. This generative system embraces two main policies, in order for it to acquire flexibility; computational and material-based design. For this reason, we propose the construction through a framework of designed anisotropy of a generative system in order to actualize the convergence of material, structure and form.

2.1. Computational design

Initially, we inherit policies of integrated computational design strategies and algorithmic descriptions, through a set of rules and mechanisms. As explained by P. Coates in [1], computational design strategies are proved beneficial, while they provide a link between process and a larger approach towards architecture. Computational processes are based upon enacting discrete behaviors, within a generative modeling environment. Moreover, they address complexity issues, allowing continuous reprogramming through manipulation of interrelated mechanisms. Through computer-aided design, complexity of the environment can be implemented in an intelligent, procedural manner. Computational design methods implement the use of algorithms in modeling, which are important in hypothesis testing and event simulation by transcription of information into a series of emergent situations, which respond each time to context stimuli. Computer acts as a translator, as the controller of the series of algorithmic procedures, as well as the provisory interface between the future user and the object (which will address real world issues).

2.2. Material-based design

Withal, a second material-based policy is suggested in order to address tectonic issues. We adopt a material-based computational design approach, under which the material itself is the component and the material system at the same time. We further examine the benefits of materiality incorporated in the design procedure generatively. Integrated material properties in computationally enabled form generation consist a flexible

system that is built up from the equivalent materiality features as its context, sharing the same genotype. The system incorporates nature strategies that refer to ergonomics, which is approximated by our systemic approach, through local material property variation. Under the terms of anisotropy and heterogeneity, we form a complete system of tailored, differentiated properties, through the control of the behavior of physical and mechanical properties. This results in highly efficient structures that embody inherent dynamical prospects, customized to their environment and tailored to support range of constraints.

3. Decomposition to subsystems

In the proposed project, the design concept is broken down into multiple single-disciplinary parts. We decompose our generative mechanism into separate parts, in order to examine them as independent domains and then recombine them to a whole interrelated procedure, adapted to its context. These separate domains, become a set of interrelated subsystems that can collectively produce a design solution. Each subsystem could also include nested smaller design systems, forming finally a high level view of the design system. Therefore we refer to a complexity that deals with the subdivision of tasks that converge into skillful solutions.

Two main subsystems are depicted, internal and external, in order to model and systematize our procedure. Postliminary, we will argue the full integration of these two subsystems, into a new ecosystem. The internal subsystem consists of a group of interrelated sub-mechanisms, describing procedures that formulate a collection of design parameters, rules or algorithms, represented within a computational environment, in order to control their correlations. The external subsystem corresponds to the context in which the above mechanisms develop. We depict this separation in order to understand sufficiently the conversion of the internal mechanisms towards a compound system that addresses adaptation. Context is regarded to contain the attributes of a complex, self-sustainable environment, from materiality features, to climate, structure and human factor. Since we are working at the design concept stage, the level of detail of the above attributes constitutes a simplification of reality. Subsequently, by dividing our system into discrete parts we approximate a top-down approach, under which, we set the main aspects and objectives of each discipline.

3.1. Internal subsystem

We now demonstrate the articulation of the internal subsystem. It corresponds to an allocation of discrete spatial mechanisms, based on the capacity to correspond to a generic arrangement. In order to understand these design mechanisms, we need to model them in a computational environment. We are concerned with structural and material-based computation in order to build a series of systemic representations that correspond to an adaptive, generic formation that expresses heterogeneity among the phases of each procedure. In this way, the assembled procedures will emancipate a fully adaptive generative mechanism. The internal subsystem consists of three design mechanisms that function together as a unit. These are; a growth protocol system, a material distribution mechanism and a structural system.

3.1.1. Protocol

In regards to the previous, the first mechanism to be analyzed is the formation of a protocol system. Considering the before-mentioned attributes about intelligence and adaptation, we continue in combining them into a growth system, which is the development protocol. We examine the potential of digital branching growth systems to be applied in the design process. This strategy derives from the phenomenon of tropism. Tropism indicates the environmental adaptation of a system, through its movement and growth, depending on external stimuli. The growth protocol forms a generic bifurcation system, which describes the development of every bottom-up branching structure, through a series of generations.

The modeling of the whole procedure has been simulated in 3D Studio Max Design, as presented in Figure 1, through a set of rules that control certain parameters, such as system's height, bifurcation type and generations (number of branches and nodes), angle and spread of the branches. Initially, the system operates within a state of a given number of nodal points (3 to 4). As the system starts developing, certain nodal points are activated creating additional branches according to a hierarchy that forms a relation of parent-child in the bifurcation process. The parameter manipulation ensures the infinite number of variations that can be produced from the algorithm. This protocol constructs an irregular arborescent structure. Unlike a regular tree structure, the branching components relocate and deform, satisfying multiple performance and objective requirements, such as adjacency, proportion and stability. The protocol responds to the general approach of an open-ended, decentralized system, through local, simultaneous accretion of various nodes. It forms a ceaseless procedure, as its architecture is based on the principles of random growth and incompleteness.

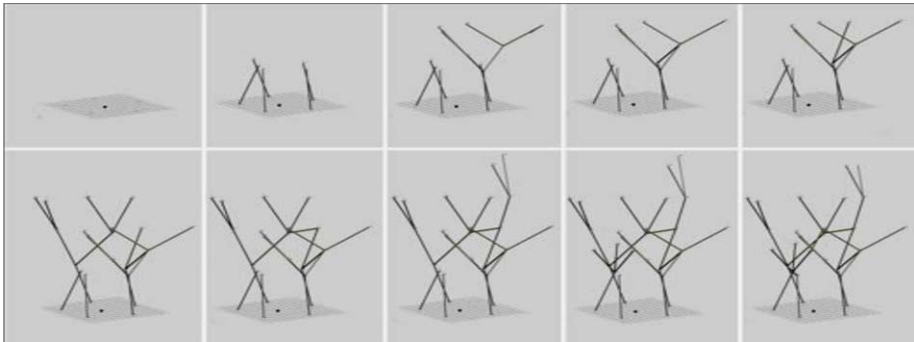

Figure 1. Stages of the development protocol.

3.1.2. Material distribution

The second set of design rules deals with the allocation of material distribution, addressing three interrelated factors. The first two answer to structural efficiency issues of the structure, such as stiffness and elasticity, while the last deals with spatial issues, such as porosity and lighting performance. This mechanism is based on simplified assumptions that aim in capturing the fundamental relationship between the geometrical shape of the structure and its structural and environmental performance.

Structural efficiency is provided by topology and structural optimization methods. These methods are mathematical approaches that optimize material layout within a given design space, for a given set of loads and boundary condition in order to output the best structure performance and material distribution. The calculations are carried out through finite element methods for the analysis of load, support and density regions. The modeling of this procedure is simulated in Topostruct software, as described in Figure 2. This method consists a mesh generation technique that operates with given material properties, load and support regions. Hence, material distribution is organized in the most ergonomic way, meaning that the system proposes the least amount of material, in order to achieve structural efficiency.

The important aspect about this method is that it can be applied in multiple potential cases, including heterogeneity as a potential policy. It is suitable for non-linear phenomena that include domains that change their attributes, such as boundaries, precision etc. At the same time, porosity and light performance of the structure are also assessed by material distribution. Surface thickness is assigned to curvature values, while transparency is assigned to light analysis values. They comprise secondary procedures that are calculated simultaneously along with the primary procedure, which refers to structural efficiency. What needs to be clarified here is that performance is also adhered from external parameters, such as context conditions and human interference. The benefits of this mechanism are its potential capacities in advance to adapt to every design concept case.

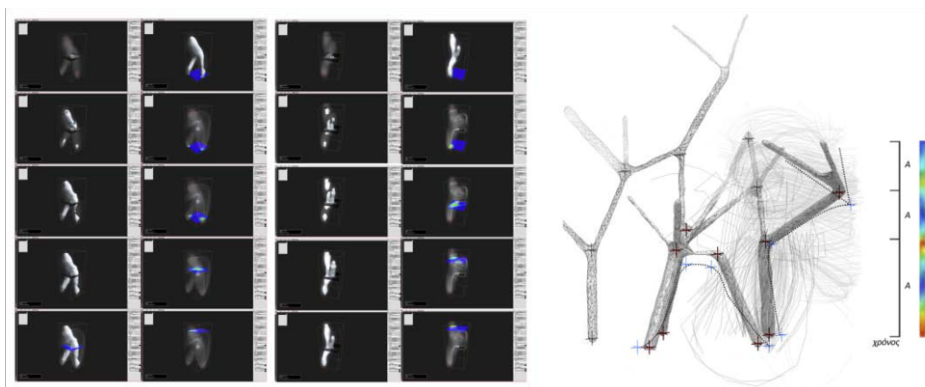

Figure 2. Topology optimization evaluations simulated in Topostruct software.

3.1.3. Structural system

At this point, our research focuses on the pursuit of structures that can embody dynamical prospects. We search for a generic microstructure that would enclose all the above strategies, concerning heterogeneity and adaptation in materiality prospect. We conclude on incorporating attributes of fibrous composite structures, as they introduce and exploit heterogeneity and anisotropy in both micro and macro level. As N. Oxman denotes [2], fibers represent physical line elements providing paths for transmitting, transferring and diffusing mechanical and chemical information into structures. They

form a generic structure commonly found to more complex meshworks that vary in the scalar factor and acquire good structural performance despite their light weight.

Possible structural behaviors of such a system include weaving and bundling of fibers, bifurcation and disconnection of threads. So, knitting and braiding practises are incorporated in the design process for the structural system. Knitted structures allow the formation of complex, generic patterns, as they refer to infinite procedures through local interventions on the system. As a result of their procedural development, they embody alterations along with their growth. This structural system addresses the terms of anisotropy and heterogeneity, as it composes by the same set of rules differentiated elements, such as membranes or elongated structural elements. In addition to that, knitted structures express a significant advantage in combining progressiveness with structural efficiency. We refer to the construction of monocoque structures, as a unified structural skin where surface and solid structures are fully integrated into one structural system. As a result, this structural system is proved to summon up all desired aspects, in order to be encountered in the whole generative mechanism.

3.1.4. Re-composition of internal subsystem

As opposed to decomposition of the internal subsystem, we proceed on a bottom-up approach, under which the discrete mechanisms are connected into a data flow network of simultaneous procedures. The internal system forms an interrelated set of rules allowing continuous feedbacks. It is defined by generations, through which the protocol system develops. Including all potential variations, the developing mechanism works in collaboration with the material distribution mechanism, as the second derives from structural considerations testing the required amount of material. According to Figure 3, material is distributed through local analysis of the knots, from the nodal points that are most loaded towards the edges. The structural optimization algorithm captures the local effects of the construction algorithm. The simulation is achieved by the set up of discrete particle systems at each nodal point of the construction and a non-homogenous distribution of particles that indicate the material density at each point, according to the load charges. These two mechanisms control the viability of the development.

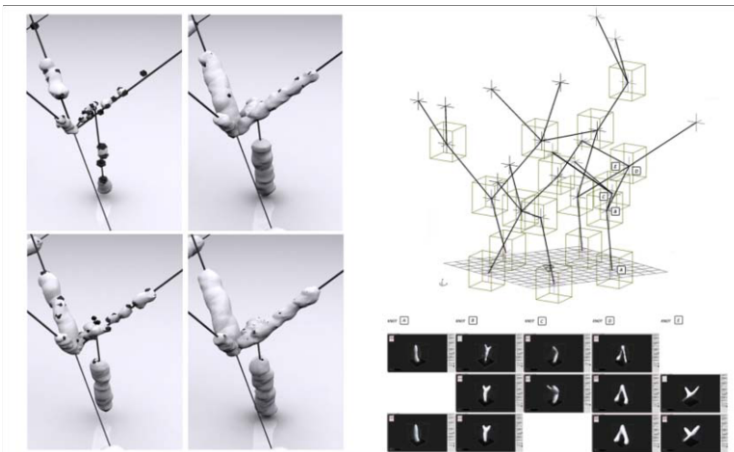

Figure 3. Material distribution mechanism.

As the construction protocol develops without pre-established programmed plan, each new added branch requires for evaluation in advance, of the whole already built structure. The evaluation method involves local intervention to the system in retrospect, as it can be locally reinforced, according to the system's growth. Thus, the heterogeneity, considering material distribution, emerges, according to the contingent stages of the growth protocol. This differentiation that derives from the non-homogenous material distribution is depicted in Figure 4.

At this point, we demonstrate the employment of the final mechanism and its correlation to the assembly. The third mechanism is related to the actualization of the above set of rules, through a complying set of internal rules, those of knitting and braiding systems. This mechanism receives relevant data from the whole system, in order to adapt the structure to the given conditions. As argued, knitted structures correspond to heterogeneity policies therefore; the 3D knitting procedure is integrated into the general algorithmic development, creating a 3D knitted structural meshwork. This meshwork is consisted of continuous braided elements, therefore it has the capacity to adapt to the bifurcation algorithmic protocol, as these elements can be separated, forming thinner elements and re-joined, forming thicker ones, according to their neighbor components and load charges. However, knitted structures respond partially to material thickness constraints, as they are driven by straightforward procedures, therefore they cannot fully adapt to evaluation and local reinforcements of the structure. For that reason, we propose a composite system of a knitted structural core and a surrounding skin of variable thickness. We finally proceed in a case of a composite monomaterial structure, which can be locally differentiated by modification of the material attributes.

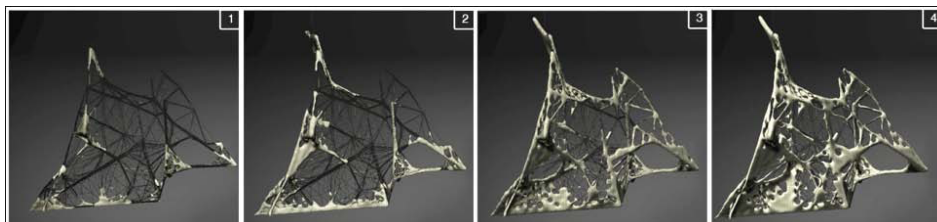

Figure 4. Different stages of material accumulation.

3.2. External subsystem

At this point, we address the external subsystem, which concerns applied methods interrelated with realistic conditions. Referring to a natural environment, it is important to provide a design that exploits energy and in situ materials in a sufficient way. In association to the general material-based policy that was brought up before, we search for a single material, defined by specific characteristics. These characteristics include implementation of fibrous structures, abundance on context and flexibility on application. For these reasons, we bring forth the use of fibrous, viscous, thermoplastic polymers that gather every prospect in developing unique properties in micro and macro scales, as they operate in a molecular state.

According to recent researches about novel materials [3], it is now possible to create new hybrid materials through synthesizing an organic-inorganic composite via molecular-level manipulation. Polylactide (PLA) is one of an important group of thermoplastics and has lately received much attention due to its flexibility and biodegradability. PLA composition is a complex process and includes a series of procedures and chemical reactions until it reaches the final stage. Briefly, this includes harvesting of natural, herbal raw material in abundance, dissolution, in order to collect useful substances (cellulose, starch, chitin), hydrolysis and fermentation for lactic acid composition and two stages of polymerization, to produce high molecular mass compound polymer. Finally, certain, additional, supportive elements are implemented to the final material, in order to adjust its mechanical and chemical properties. These additions are PHBHHx and titanium dioxide (TiO₂) that enhance structural performativity and allow the synthesis of a photocatalytic material for fission and degradation of atmospheric pollutants, as it is described in Figure 5.

The final addressed subject is the interference of human, as domain of uncertainty. Besides environmental stimulus, human corresponds to an additional stimulus element that affects the system's behavior. Several mechanisms congregate, so the structure acts as scaffold for human interaction. Bringing the concept around tropism to the forefront, growth is complied with human encounter, by adjusting its directional vectors. Furthermore the density of inhabitation is indicated by local structural adjustments. The construction system forms membranes, in order to incorporate inhabitation capacity, growing a protective skin, adjusted to the same rules of continuity along with the other procedures. The structure is emancipated from customary inhabitation; therefore it is a challenge that requires human desire for adaptation vice versa. It either compels the human body to crawl, or permits to be released, to stand defining different spatial qualities. At this point, it needs to be clarified that the proposed generative mechanism is about a multi-performative design platform rather than the design of a user interface platform. This means that personalization and customization of needs between the individuals are not involved in the system. The mechanism allows the dynamic insertion of human as an entity that affects the mode and density of the construction, subjected to collective constraints, such as accessibility and structural efficiency.

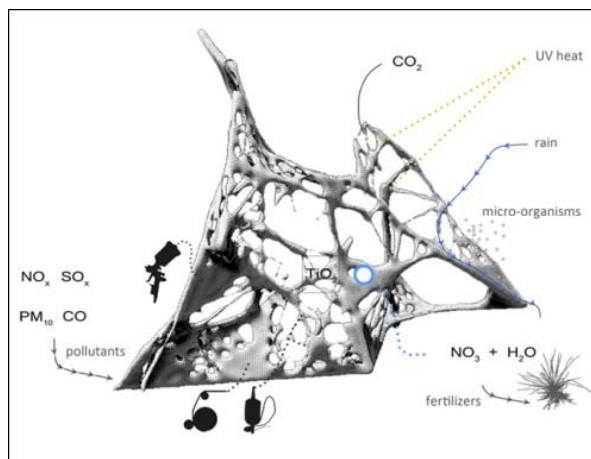

Figure 5. Diagram of ways of application on the structure and material's behavior.

3.3. System in operation

Our research should provide for a coherent way of production, inferring the development of machinery in collaboration, in order to transcribe algorithmic protocols into a material factum. We refer to adaptive technology, artificial apparatuses, which actualize the multiplicity of contextual and human behaviors, through a procedural, non-deterministic way of production. These artificial apparatuses follow a specific control process, which consist of: sensing, sampling, actuating, controlling tend to emphasize material responses. Our research should provide for a coherent way of production, inferring the development of machinery in collaboration, in order to transcribe algorithmic protocols into a material factum.

As the construction algorithm responds to internal and external data inputs, this segregation is also implemented to define a system of two supplementary machines, one external and one internal. This machinery pair is driven by corresponding machinery protocols, which lead to the system's convergence and to ever-emerging artificial biotopes. The external machine is equivalent to a containment device, a raw material collector and depository. It allocates a primary source of raw material, which is identified as the initial point of the construction. The internal machine's purpose is to build the structure in real time, through the synthesis of the structural material, by employing climbing technologies to freely move through the branches of the structure, as well as embedded material composition technology. It is about a complex articulation, sort of a medium scale computer-driven, 3D knitting machine, with the ability to sense the human factor and adapt its machinery protocol at every instant. The protocol executes simultaneous processes, by applying knitting and braiding procedures in an intelligent way, producing differentiated environments, according to the systems capacities. This mode of construction is not only emancipated from standard building procedures, but also makes it possible to reprogram construction even while it is under way, so it becomes possible to change the construction plan in real-time while the structure is being built. Multiple nozzles can work in unison to extend various parts of the structure in different directions and simultaneously compose the material, which is milled and applied in various ways. It may be pumped in premix paste form, or it may be sprayed or even form membranes, all these, carried out through the machine's sensitive nozzles. The machinery pair is responsible for the viability and variability of the structure.

4. Re-composition of design system

At this point, we continue in recomposing the design concept, as a whole interrelated unit that generates a solution to multi-performance issues and proves the overall performance on the design solutions. The proliferating, arborescent network breeds a symbiotic structure, grown in natural environments, which fill in for the necessary conditions for its existence. It is an adaptive landscape, a biotropism based on local growth procedures, which are they in a constant state of evolution. Due to the multi-objective nature of the system, the aim was not to produce a single optimal design solution but instead, a system that generates populations of valuable behaviors. The whole system converges momentarily to produce series of results. These results are unique outputs of the same procedure, defined as object-events, or rather objectiles. This mode of construction is not only emancipated from standard building procedures,

but also makes it possible to re-program construction even while it is under way, so it becomes possible to change the construction plan in real-time while the structure is being built.

Growth is affected by human interference and simultaneously, subjected to collective constraints, such as accessibility and structural efficiency. Sections by section, the composite materials of the structure undergo biodegradation in a short-term perspective, in order to avoid permanent occupation and any sense of individual ownership, as well as for environmental reasons. Therefore, the construction becomes part of the landscape. Its growth is artificial and synthetic, adopting the formlessness of nature, described as a plug-in inserted into the environment that gradually merges with it. The biodegraded biostructure is transformed into fertilizer, through decomposition of its fragile tissue, therefore a closed; recursive circuit is created between these biotopes. However, this decomposition does not characterize the overall biostructure homogeneously, due to differentiated growth potentialities and local reinforcements in order to carry out invasive inhabitation. This partial decay imprints every state of inhabitation and contextual resistance and is affiliated with terms of recursive incompleteness. It cannot be perceived in its totality, as the structure's maximum capacity state remains undiscovered in a regime of uncertainty.

The following outline in Figure 6 represents the proposed mechanism as a whole. The mechanisms are represented by continuous line circles of variable size, as well as a short name. Dashed line circles represent the formed systems. The outer circle indicates the overall system that includes the subsystems, forming a holistic unit. It is the generative mechanism. The overall system consists of three subsystems and their sub-mechanisms. The lines that link every system or mechanism are not arrows with specific trend, because all the mechanisms form an interactive network of bi-directional connections. External parameters (context, material resources, human) are represented as an equal separate subsystem.

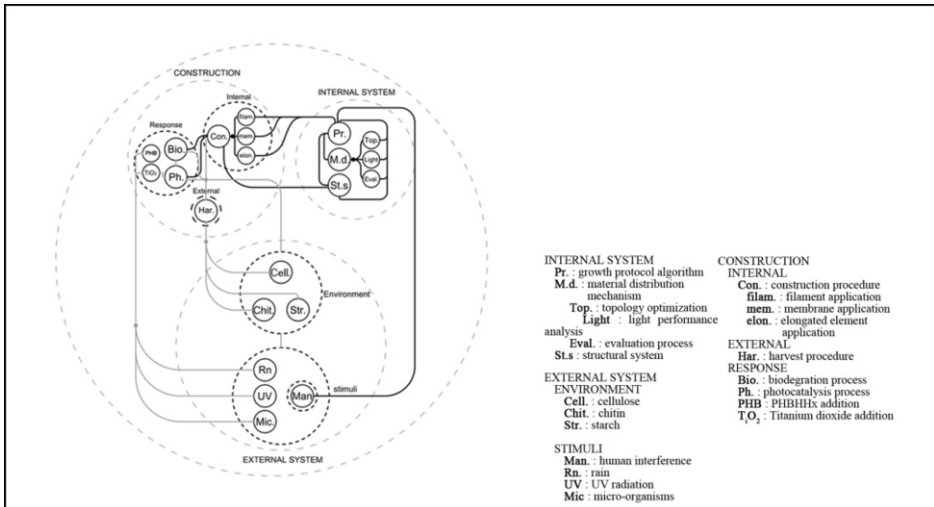

Figure 6. Generative mechanism diagram that represents the interrelation of the proposed subsystems.

5. Conclusion

The arousal of intelligent thinking in architecture establishes the convergence of different fields, such as biology, chemistry, physics, computation, new materialism, complexity and emergence theories. It is crucial that we invent non-linear strategies, which challenge emergent architecture, to facilitate symbiotic behaviors, as well as possibilities for adaptable re-combinations. Traditionally, we have a tendency to address an analytical problem-solving framework towards one single optimum solution. Through this paper it becomes apparent that processes of dynamic reconfigurations can be considerably extensive, providing a variety of growth models that respond to scenarios in a constant state of renegotiation.

Heading off previous thought and design that dealt with deterministic rigid schemas, new objects emerge out of this ecology of interaction by means of consecutive exchange of information at all levels. By introducing research in engineering materials both responsive and sustainable, as well as novel design systems, we address modes to produce an architecture programmed to respond to environmental changes, providing the opportunity to converge ecological thinking, social interaction and active materiality. Through this paper we bring about concepts that help us conceive the necessity of intelligent synergetic mechanisms in the formation of non-linear, interdisciplinary design methods.

6. Acknowledgments

The paper is based on our Diploma Design Project "Der Bau - To Ktisma", School of Architecture, Faculty of Engineering, Aristotle University of Thessaloniki, February 2013, supervised by assistant professors Vergopoulos Stavros, Tellios Anastasios.

References

- [1] P. Coates, *Programming. architecture*, Routledge, New York, 2010.
- [2] N. Oxman, *Material-based Design Computation*, Massachusetts Institute of Technology, June 2010.
- [3] C.S.Wu, In Situ Polymerization of Titanium Isopropoxide in Polycaprolactone: Properties and Characterization of the Hybrid Nanocomposites, Department of Chemical Engineering, Kao Yuan Institute of Technology, Kaohsiung County, 2003.

Cardiac Arrhythmia Classification Using KNN and Naive Bayes Classifiers Optimized with Differential Evolution (DE) and Particle Swarm Optimization (PSO)

Christian PADILLA-NAVARRO ^{a,1}, Rosario BALTAZAR-FLORES ^a,
David CUESTA-FRAU ^b, Arnulfo ALANIS-GARZA ^c and
Victor ZAMUDIO-RODRÍGUEZ ^a

^a *Division of Research and Postgraduate Studies, Leon Institute of Technology, Av. Tecnológico S/N Col. Industrial Julián de Obregón, 37290, León, Mexico*

^b *Technological Institute of Informatics, Polytechnic University of Valencia, Campus Alcoi, Plaza Ferrándiz y Carbonell, 2, 03801 Alcoi, Spain*

^c *Division of Research and Postgraduate Studies, Tijuana Institute of Technology, Blvd. Industrial y Av. ITR, Tijuana S/N, 22500, Mesa Otay, Tijuana, B.C, Mexico*

Abstract. In the present investigation we are looking for improve the features classification of a cardiac arrhythmias database using metaheuristics (Differential Evolution and Particle Swarm Optimization) and classifiers (KNN and Naive Bayes), with the purpose of select the main features and increase the percentage of classification. The classification percentage in some cases increased until 100% and the number of features was significantly reduced.

Keywords. ECG, Arrhythmia, Classifiers, KNN, Naive Bayes, Differential Evolution, PSO, Feature Reduction.

1. Introduction

Separate the data through different classes is the main function of the classifiers. Exist different applications of classifiers in ECG signals. In Nasiri [21] was performed the arrhythmia classification of EEG signals using Support Vector Machines (SVM) and Genetic Algorithms. In Abdeel-Badeeh [1] was applied the machine learning in a ECG diagnosis. Ramírez [24] propose a dynamic model of cardiac arrhythmia classification trough machine learning with user interface. In Mohamed [19] presented two methods for multiclass arrhythmia classification applying the Principal Component Analysis (PCA), the Fuzzy Support Vector Machine, and the Unbalanced Clustered. Kallas [12] showed the classification of multiclass arrhythmia through Support Vector Machines (SVM) mixed

¹e-mail: jocripana@ieee.org

with feature extraction through Principal Components Analysis (PCA) in ECG signals. In Thanapatay [34] proposed a new method for ECG classification using Principal Component Analysis (PCA) and Support Vector Machine (SVM). Rabee [25] presented the ECG signal classification using Support Vector Machine and based on the Multiresolution Wavelets analysis. In Shen [29] proposed a classification model using Support Vector Machine (SVM) and Independent Component Analysis and Zellmer [37] obtained the ECG signals classification based on continuous wavelet transform and Support Vector Machines (SVM).

The combination of classifiers with metaheuristics for feature selection on ECG signals is an efficient way to eliminate unnecessary data in the search of abnormal heartbeats. Martínez [17] proposes a classification model using intelligent ECG to detect heart problems using neural networks and Genetic Algorithms. In Melgani [18] was performed ECG signals classification with Support Vector Machine (SVM) algorithm applying PSO (Particle Swarm Optimization) and in Daamouche [5] they are looking for optimize the classification applying PSO algorithm, Support Vector Machines (SVM) and perform noise reduction in ECG signals through Wavelets.

In Fira [7] investigated the results of classification from the compression of ECG signals from different projection matrices. In Vaish [35] were investigated the loads of efficacy and computational efficiency of different algorithms used to recognize the emotional state through cardiovascular signals.

The ability to identify automatically ECG arrhythmia is important for clinical diagnosis and treatment. In Soman [31] have used machine learning systems, Oner, J48 and Naive Bayes to classify the data sets obtained from doctors databases. In Gao [8] was described a system for detecting cardiac arrhythmias in ECG signals, based on a bayesian artificial neural network (ANN) constructed by a logistic regression model and a BackPropagation algorithm.

2. Metaheuristics

In this work we applied several metaheuristics, Differential Evolution and Particle Swarm Optimization, mixed with a different classifiers, KNN and Naive Bayes, to find the best value in the percentage of classification.

2.1. Differential Evolution (DE)

In computer science, differential evolution (DE) is a method that optimizes a problem by iteratively trying to improve a candidate solution with regard to a given measure of quality. Such methods are commonly known as metaheuristics as they make few or no assumptions about the problem being optimized and can search very large spaces of candidate solutions. However, metaheuristics such as DE do not guarantee an optimal solution is ever found.

Differential Evolution is a small and simple mathematic model of a big and complex evolution process, this process is easy and efficient [6]. The first description of differential evolution was performed in 1995 by Price and Storn [23].

2.1.1. Population

Differential Evolution needs an initial population of a 4 individuals at least. Each individual have a vector, each vector contain a component that represent a dimension with values in the continue space, but can be used in the discrete space too.

2.1.2. Function of Adaptation

Given an individual, the adaptation function need to assign a real number, that reflects the level of adaptation to the individual problem.

2.1.3. Mutation

The mutation consists in the construction of noise random vectors **NP**, created from three random individuals, called *target vectors*. We could use different methods for the mutation process:

Using the equation OF/RAND/1:

$$temp\vec{E}_i = \vec{E}_j + F(\vec{E}_k - \vec{E}_l) \quad (1)$$

Using the equation OF/RANK:

$$temp\vec{E}_i = \vec{E}_i + F(\vec{E}_j - \vec{E}_k) \quad (2)$$

$$temp\vec{E}_i = \vec{E}_{BEST} + F(\vec{E}_{BEST} - \vec{E}_i) \quad (3)$$

Using the equation DE/CURRENT TO BEST/1:

$$temp\vec{E}_i = \vec{E}_i + F(\vec{E}_{BEST} - \vec{E}_i) + G(\vec{E}_k - \vec{E}_i) \quad (4)$$

Where $i \neq j \neq k \neq l$, F (and G for current to best) $\sim [0,2]$ is a basic parameter of input (constant in all time of the execution time), if F is less than 1 then shrinks and if F is more than 1 then grows.

2.1.4. Crosses

When we have the noise random vectors **NP**, the crosses is done randomly through the following equation:

$$tempE_i[j] = \begin{cases} tempE_i[j] & \text{if } r \leq CR \\ E_i[j] & \text{in other case} \end{cases} \quad (5)$$

Where $CR \sim [0,1]$ is a basic parameter of input (constant in all time of the execution time) and $r \sim [0,1]$ is a random number uniformly distributed.

2.1.5. Differential Evolution Algorithm to Classifier ECG Arrhythmias

Algorithm 1 Differential Evolution Algorithm.

- 1: Data input: $F \sim [0, 2]$, $CR[0, 1]$, size of the population, call functions, objective function-classifier-(1NN, 3NN, Naive Bayes), number of folds.
 - 2: Start a random population.
 - 3: Evaluate the first population.
 - 4: **while** (no finish call functions) **do**
 - 5: $tempE_i \leftarrow$ (see Equation of Mutation).
 - 6: Use sigmoid ($>1 \rightarrow 0$, $<1 \rightarrow 1$)
 - 7: **for** each coordinate j of the individual **do**
 - 8: $r \leftarrow$ uniformly distributed random number between 0 and 1.
 - 9: **if** $r \leq CR$ **then**
 - 10: $tempE_i[j] \leftarrow$ (see Crosses Equation)
 - 11: **end if**
 - 12: **end for**
 - 13: **if** $f(tempE_i)$ better $f(E_i)$ **then**
 - 14: $E_i \leftarrow tempE_i$.
 - 15: $f(E_i) \leftarrow f(tempE_i)$.
 - 16: **end if**
 - 17: **end while**
-

2.2. Particle Swarm Optimization (PSO)

PSO is a metaheuristic inspired in the social conduct of particles often applied for solving optimization problems. In 1995 Kennedy and Eberhart [14] developed the first algorithm. The algorithm can be used in continues or discrete functions. This proposal was an excellent optimization algorithm to continues no-linear math functions, but could be applied in binary too.

Basically, PSO works with a set of candidates solutions named *swarm*. Each member of the swarm is a *particle*, and this particle have a solution vector named *position*. Each particle knows the best position in the swarm o *best global*. If you defined subsets of particles in the swarm, each particle is named *neighbourhood*.

To update the velocities of the particles, we need to use the next equation:

$$v_{ij} = wv_i + \phi_1(GBest_i - x_i) + \phi_2(LBest_i - x_i) \quad (6)$$

Therefore, to realize the actualization of the value x_i we need to use a sigmoid, the equation is:

$$\overrightarrow{Sig}(V_{ij}) = \frac{1}{1 + \exp^{-v_{ij}}} \quad (7)$$

2.2.1. PSO Algorithm to Classifier ECG Arrhythmias

Algorithm 2 PSO Algorithm

```

1: Data input:  $\phi_1[0, 1]$ ,  $\phi_2[0, 1]$ , size of the population, call functions, objective function
   -classifier-(1NN, 3NN, 5NN, Naive Bayes), number of folds.
2: Start a random population and generate random velocities  $V[0, 1]$ .
3: Evaluate the first fitness of each individual, take the Best Individual and the Best Fitness
   (GBest) and save the first fitness of each individual (LBest).
4: while (no finish call functions) do
5:   for each particle  $i$  do
6:     for each member of the particle  $j$  do
7:       Update the velocities (Equation 6) and update the value of  $x_i$  (Equation 7).
8:     end for
9:     for each member of the particle  $j$  do
10:      Generate a random number  $r_{ij}[0, 1]$ .
11:      if  $r_{ij} < Sig(V_{ij})$  then
12:         $x_{ij} = 0$ 
13:      end if
14:      if  $r_{ij} > Sig(V_{ij})$  then
15:         $x_{ij} = 1$ 
16:      end if
17:    end for
18:    Evaluate the fitness of each individual (percentage of classification).
19:    Update the LBest.
20:    if  $f(x_i) > f(LBest_i)$  then
21:       $LBest_i = x_i$ 
22:    end if
23:  end for
24:  Find the best LBest
25:  if  $LBest > GBest$  then
26:     $GBest = LBest_i$ 
27:  end if
28: end while

```

3. Experimental Set-Up

3.1. Experimental Dataset

We need a experimental set to find the percentage of classification. In this research, the experimental dataset consisted of labelled ECG records from the [9] database. The experimental records were obtained from the MIT/BIH arrhythmia set. This set contains 48 recordings of 30 min duration. All the heartbeats were already labelled. However, the AAMI standard [4] recommends the consideration of the following heartbeat types: normal beat (labelled as N), Supraventricular ectopic beat (S), Ventricular ectopic beat

(V), Fusion beat (F), and unknown beat class (Q). Any of these types might be present in any record. A complete description of all the records is included in (see Table 1), showing the equivalence between the AAMI and MIT/BIH labels in the two first rows.

AAMI	N					S				V		F		Q	
MIT Code	N	L	R	e	j	A	a	J	S	V	E	F	f	P	Q
Class	1	2	3	34	11	8	4	7	9	5	10	6	38	12	13
	0000	1010	0111	1011	0101	0010	1000	0110	1100	0001	1101	1001	0100	0011	1110
100	2237					33				1					
101	1858					3									2
102	99									4		56		2026	
103	2080					2									
104	163									2		666		1378	18
105	2524									41					5
106	1505									520					
107										59				2076	
108	1738				1	4				16		2			
109		2490								38		2			
111		2121								1					
112	2535					2									
113	1787						6								
114	1818					10		2		43		4			
115	1951														
116	2300					1				109					
117	1532					1									
118			2164			96				16					
119	1541									444					
121	1859					1				1					
122	2474														
123	1513									3					
124			1529		5	2		29		47		5			
200	1742					30				825		2			
201	1623				10	30	97	1		198		2			
202	2059					36	19			19		1			
203	2527						2			444		1			4
205	2569					3				71		11			
207		1457	85			106				105	105				
208	1585								2	992		372			2
209	2619					383				1					
210	2421							22		194	1	10			
212	922		1824												
213	2639					25	3			220		362			
214		2001								256		1			2
215	3194					2				164		1			
217	244									162			260	1540	
219	2080					7				64		1			
220	1952					94									
221	2029									396					
222	2060				212	208		1							
223	2027			16		72	1			473		14			
228	1686					3				362					
230	2253									1					
231	314		1252			1				2					
232			396		1	1381									
233	2229					7				830		11			
234	2698							50		3					
TOTAL	74986	8069	7250	16	229	2543	150	83	2	7127	106	802	982	7020	33
The first row corresponds to the labels used according to the AAMI standard, and the second row lists the labels used in the MIT/BIH database.															
The third row corresponds to the numerical code of these last labels.															
The first column is the name of the records, whereas the others contain the number of heartbeats of each type.															

Table 1. Set of recordings of the MIT/BIH database used in the experiments.

3.2. Feature Extraction

Feature extraction consists in obtain the main features of the arrhythmia signal to classify after. For the feature extraction in this research, we took like a reference the extraction of Rodríguez-Sotelo [28]. The initial input feature vectors $x_j = \{x_{1j}, x_{2j}, \dots, x_{pj}\}$, with $p = 100$ were composed of:

$$x_{1j} = l_j - l_{j-1} \text{ (RR interval)}$$

$$x_{2j} = l_{j-1} - l_{j-2} \text{ (pre-RR interval)}$$

$$x_{3j} = l_{j+1} - l_j \text{ (post-RR interval)}$$

$$x_{4j} = x_{1j} - x_{2j}$$

$$x_{5j} = x_{3j} - x_{1j}$$

$$x_{6j} = \left(\frac{x_{3j}}{x_{1j}}\right)^2 + \left(\frac{x_{2j}}{x_{1j}}\right)^2 - \left(\frac{1}{3} \sum_{k=1}^3 x_{kj}^2 \log(x_{kj}^2)\right)$$

x_{7j} quantifies the morphological dissimilarity between current QRS-complex, and a linearly averaged QRS-complex of the last 10 complexes [32] by means of a dynamic time warping (DTW) approach.

$$x_{8j} = \left| \frac{\max\{QRS_j[t]\}}{\min\{QRS_j[t]\}} \right|$$

$$x_{9j} = \sum_{k=0}^{L_j} QRS_j[t]^2$$

x_{10j} to x_{19j} correspond to the Hermite coefficients.

4th-level coefficients of a Daubechies-2, (dB2), Wavelet heartbeat decomposition (A-Amplitude, D-Detail)

$$x_{20j} \text{ to } x_{25j} \leftarrow A_4$$

$$x_{26j} \text{ to } x_{31j} \leftarrow D_4$$

$$x_{32j} \text{ to } x_{42j} \leftarrow D_3$$

$$x_{43j} \text{ to } x_{58j} \leftarrow D_2$$

$$x_{59j} \text{ to } x_{90j} \leftarrow D_1$$

$$x_{91j} \text{ to } x_{95j} = \text{var}\{A_4, D_4, D_3, D_2, D_1\}$$

$$x_{95j} \text{ to } x_{100j} = \text{max}\{A_4, D_4, D_3, D_2, D_1\}$$

4. Experiments and Results

We made different experiments for the classification. In the case of PSO we used the next parameters: $\phi_1 = 0.3$, $\phi_2 = 0.5$ y $w=0.7$. In the case of Differential Evolution, the parameters were $F = 0.9$ and $cr = 0.5$.

First tests were with the classifiers 1NN, 3NN and Naive Bayes, without metaheuristics. We considered all characteristics to take an initial parameter and to can compare an improvement. Next, we test with the same classifiers, but with the PSO and with Differential Evolution Algorithms.

We can see the Medium of the Percentage of Classification obtained (see Table 2) and the Medium of the Number of Characteristics used in the classification (see Table 3).

Classifier	KNN (1NN)	KNN (3NN)	Naive Bayes	Naive Bayes	Naive Bayes
Population	5	5	5	5	10
Fold	2	2	2	10	10
Call Functions	20	20	20	20	50
without algorithm	94.11%	94.71%	9.72 %	9.93 %	9.93%
PSO	93.38%	94.59%	17.24 %	21.80 %	28.0%
Differential Evolution	93.94%	94.07%	19.50 %	17.46 %	15.75%

Table 2. Medium of Classification Percentage.

Classifier	KNN (1NN)	KNN (3NN)	Naive Bayes	Naive Bayes	Naive Bayes
Population	5	5	5	5	10
Fold	2	2	2	10	10
Call Functions	20	20	20	20	50
without algorithm	100	100	100	100	100
PSO	36.8	53.8	28.6	34.6	31.2
Differential Evolution	50	45.6	29.2	38.4	39.4

Table 3. Medium of Number of Characteristics Used in the Classification.

4.1. Weight of the Characteristics

Taking as 50 the maximum number of times that each feature could be chosen, these are the results for each characteristic:

Characteristic	Number of Times Selected	Characteristic	Number of Times Selected
1	19	26	22
2	18	27	21
3	24	28	22
4	24	29	19
5	20	30	21
6	19	31	22
7	29	32	15
8	24	33	16
9	22	34	20
10	14	35	20
11	12	36	20
12	22	37	23
13	19	38	27
14	14	39	18
15	19	40	19
16	19	41	22
17	27	42	20
18	21	43	22
19	19	44	21
20	18	45	19
21	20	46	18
22	20	47	13
23	19	48	21
24	23	49	22
25	28	50	20

Table 4. Weight of the Characteristics (1 to 50).

Characteristic	Number of Times Selected	Characteristic	Number of Times Selected
51	20	76	22
52	21	77	15
53	19	78	18
54	20	79	4
55	19	80	11
56	14	81	17
57	21	82	25
58	17	83	17
59	16	84	18
60	22	85	20
61	24	86	14
62	17	87	26
63	18	88	23
64	16	89	22
65	24	90	22
66	18	91	16
67	17	92	15
68	12	93	21
69	20	94	19
70	19	95	18
71	17	96	23
72	16	97	13
73	19	98	16
74	19	99	21
75	25	100	16

Table 5. Weight of the Characteristics (51 to 100).

4.2. Non Parametric Wilcoxon Signed-Rank

Using the non-parametric Wilcoxon Signed-Rank, and seeing the Table 2, we can observe that:

In the comparative of methods Without Algorithm (T^-) and PSO (T^+), because $T = \min(T^-, T^+) = (5, 10) = 5$ y $T_0 = 1$, we can't conclude that $T \leq T_0$, and we can't accept the alternative hypothesis H_A . Is not possible determined if the PSO Algorithm or the method without algorithm is more nearly to the right.

In the comparative of methods Without Algorithm (T^-) and Differential Evolution (T^+), because $T = \min(T^-, T^+) = (9, 6) = 6$ y $T_0 = 1$, we can't conclude that $T \leq T_0$, and we can't accept the alternative hypothesis H_A . Is not possible determined if the Differential Evolution Algorithm or the method without algorithm is more nearly to the right.

In the comparative of methods PSO (T^-) and Differential Evolution (T^+), because $T = \min(T^-, T^+) = (12, 3) = 3$ y $T_0 = 1$, we can't conclude that $T \leq T_0$, and we can't accept the alternative hypothesis H_A . Is not possible determined if the PSO Algorithm or the method Differential Evolution is more nearly to the right.

5. Conclusions

After performing different tests applying PSO and Differential Evolution mixed with KNN and Naive Bayes Classifiers, although the features reduction was excellent, and in some cases the increase in the classification rate becomes even higher than 100%, the statistical tests, non parametric signals Wilcoxon test, tell us that we can't determined

what algorithm is better PSO, AG or without algorithm, but feature reduction guarantee significant savings in time classification, which is essential in this topic.

As future work, we would propose a new classification algorithm, features reduction through principal component analysis, propose a new metaheuristic or improve the already proposed.

Acknowledgements

Thanks to Consejo Nacional de Ciencia y Tecnología (CONACyT), for their support to carry out this research, and thanks to the project 4573.12-P of DGEST.

References

- [1] Abdeel-Badeeh M. Salem, Kenneth Revett. Machine Learning in Electrocardiogram Diagnosis. International Multiconference on Computer Science and Information Technology, 978-83-60810-14-9:429-433, 2009.
- [2] Arruda J.E. , McGee H.A., Zhang H. , Stanny C.J. The Effects Of EEG Data Transformations On The Solution Accuracy Of Principal Component Analysis, *Psychophysiology* 48 (3) (2011) 370–376, <http://dx.doi.org/10.1111/j.1469-8986.2010.01067.x>.
- [3] Castells F. , Laguna P. , Sornmo L. , Bollmann A. , Roig J.M. , Principal Component Analysis In ECG Signal Processing. *EURASIP Journal of Applied Signal Process* 2007 (2007), 98–98.
- [4] De-Chazal P., O'Dwyer M. , Reilly R. Automatic Classification Of Heartbeats Using ECG Morphology And Heartbeat Interval Features, *IEEE Transaction on Biomedical Engineering* 1 (7) (2004) 1196–1206.
- [5] Daamouche Abdelhamid, Latifa Hamami. A Wavelet Optimization Approach For ECG Signal Classification. *Biomedical Signal Processing and Control*, 7:342–349, 2012.
- [6] Feoktistov, V. *Differential Evolution: In Search of Solutions*. Springer, 2006.
- [7] Fira Monica, Liviu Goras. On The Projection Matrices Influence In The Classification Of Compressed Sensed ECG Signals. *International Journal of Advanced Computer Science and Applications*, 3, 2012.
- [8] Gao Dayong , Michael Madden. Bayesianann Classifier For ECG Arrhythmia Diagnostic System: A comparison Dstudy. *IJCNN*, 2005.
- [9] Goldberger A.L., Amaral L.A.N., Glass L., Hausdorff J.M., Ivanov P.C., Mark R.G., Mietus J.E., Moody G.B., Peng C.K., Stanley H.E., PhysioBank, PhysioToolkit, and PhysioNet: components of a new research resource for complex physiologic signals, *Circulation* 101 (23) (2000) e215–e220, [circulation Electronic Pages: http://circ.ahajournals.org/cgi/content/full/101/23/e215](http://circ.ahajournals.org/cgi/content/full/101/23/e215).
- [10] Hayano J. , Sakakibara Y. , Yamada A., Yamada M., Mukai S., Fujinami T., Yokoyama K. , Watanabe Y., Takata K., Accuracy Of Assessment Of Cardiac Vagal Tone By Heart Rate Variability In Normal Subjects. *The American Journal of Cardiology* 67 (2)(1991) 199–204.
- [11] Hoya T. , Hori G. , Bakardjian H. , Nishimura T. , Suzuki T. , Miyawaki Y., Funase A. , Cao J. Classification Of Single Trial EEG Signals By A Combined Principal + Independent Component Analysis And Probabilistic Neural Network Approach. In: *International Symposium on Independent Component Analysis and Blind Signal Separation*, 2003.
- [12] Kallas Maya, Clovis Francis. Multi-class SVM Classification Combined With Kernel PCA Feature Extraction of ECG Signals. *International Conference on Telecommunications*, 978-1-4673-0747-5, 2012.
- [13] Karamchandani S., Desai U.B., Merchant S.N., Jindal G.D. Principal Component Analysis Based Back-Propagation Algorithm For Diagnosis Of Peripheral Arterial Occlusive Diseases. In: *CCECE, IEEE*, 2009, pp. 482–485.
- [14] Kennedy J. Particle Swarm Optimization Proceedings of the 1995. *IEEE international conference on neural networks, (ICNN95)*, 1995, 4, 1942-1948.
- [15] Liu H. , Yu L. Toward Integrating Feature Selection Algorithms For Classification And Clustering. *IEEE Transactions on Knowledge and Data Engineering* 17 (4) (2005) 491–502, <http://dx.doi.org/10.1109/TKDE.2005.66>.

- [16] Luo Z., Wu X., Guo S., Ye B. Diagnosis Of Breast Cancer Tumor Based On PCA And Fuzzy Support Vector Machine Classifier. *International Conference on Natural Computation* 4 (2008) 363–367, doi:<http://doi.ieeecomputersociety.org/10.1109/ICNC.2008.932>.
- [17] Martínez A.I., Rojas. Utilización de Sistemas Inteligentes Para La Detección De Problemas Del Corazón Mediante ECG, 2005.
- [18] Melgani Farid. Classification of Electrocardiogram Signals With Support Vector Machines And Particle Swarm Optimization. *IEEE Transactions On Information Technology In Biomedicine*, 12:5, 2008.
- [19] Mohamed Cherif Nait-Hamoud. Two Novel Methods for Multiclass ECG Arrhythmias Classification Based on PCA, Fuzzy Support Vector Machine and Unbalanced Clustering. *IEEE*, 978-1-4244-8611-3:140-145, 2010.
- [20] Monasterio V. , Laguna P. , Martinez J.P. Multilead Analysis Of T-Wave Alternans In The ECG Using Principal Component Analysis. *IEEE Transactions on Biomedical Engineering* 6 (7) (2009) 1880–1890.
- [21] Nasiri Jalal A., Mahmoud Naghibzadeh. ECG Arrhythmia Classification With Support Vector Machines and Genetic Algorithm. *Third UKSim European Symposium on Computer Modeling and Simulation*, 978-0-7695-3886-0:187–192, 2009.
- [22] Pagani R.G.N.D.N.F.M., Salmaso D. , Principal Component Analysis In Mild And Moderate Alzheimer's Diseasea Novel Approach To Clinical Diagnosis. *Psychiatry Research: Neuroimaging* 173 (2009) 8–14.
- [23] Kenneth V. Price, Rainer M. Storn, J. A. L. *Differential Evolution: A Practical Approach To Global Optimization*, 2005.
- [24] Ramírez López. Modelo de Clasificación Dinámico de Arritmias Cardiacas Mediante Aprendizaje de Máquina con Interfaz de Usuario. *Ciencia y Tecnología Neogranadina*, 16/002:56–95, 2006.
- [25] Rabea Ayman. ECG Signal Classification Using Support Vector Machine Based On Wavelet Multiresolution Analysis. *The 11th International Conference on Information Sciences, Signal Processing and their Applications: Special Sessions*, 978-1-4673-0382-8:1319–1323, 2012.
- [26] Rocchi L., Chiari L., Cappello A., Horak F.B. Identification Of Distinct Characteristics of Postural Sway In Parkinsons Disease: A Feature Selection Procedure Based On Principal Component Analysis. *Neuroscience Letters* 394 (2) (2006) 140–145.
- [27] Rodríguez-Sotelo J.L. , Delgado-Trejos E. , Peluffo-Ordoñez D.H., Cuesta-Frau D. , Castellanos-Domínguez C.G., Weighted-PCA For Unsupervised Classification Of Cardiac Arrhythmias. In: *Annual International Conference of the IEEE Engineering in Medicine and Biology Society (EMBC)*, 2010, pp. 1906–1909, <http://dx.doi.org/10.1109/iembs.2010.5627321>.
- [28] Rodríguez Sotelo J.L., Peluffo-Ordoñez D., Cuesta-Frau David, Castellanos-Domínguez G. Unsupervised Feature Relevance Analysis Applied To Improved ECG Heartbeat Clustering. 2012.
- [29] Shen Mi, Liping Wang. Multi-lead ECG Classification Based On Independent Component Analysis And Support Vector Machine. *3rd International Conference on Biomedical Engineering and Informatics (BMEI)*, 978-1-4244-6498-2:960–964, 2010.
- [30] Smith J.A., Drake R., Simpson A., Woodcock A, Pickles A., Custovic A. Dimensions Of Respiratory Symptoms In Preschool Children: Population-Based Birth Cohort Study. *American Journal of Respiratory Critical Care Medicine* 177 (12) (2008) 1358–1363.
- [31] Soman Thara. Classification Of Arrhythmia Using Machine Learning Techniques. *ICOSSE*, 2005.
- [32] Sornmo L. , Laguna P. *Bioelectrical Signal Processing In Cardiac And Neurological Applications*. Academic Press Series in Biomedical Engineering, Academic Press, 2005, ISBN 0124375529.
- [33] Tadevosyan-Ieyfer O., Dowd M., Mankoski R., Winklosky B., Putnam S., McGrath L. , Tager-flusberg H., Folstein S.E. A Principal Components Analysis Of The Autism Diagnostic Interview-Revised. *Journal of the American Academy of Child and Adolescent Psychiatry* 42 (7) (2003) 864–872, <http://dx.doi.org/10.1097/01.CHI.0000046870.56865.90>.
- [34] Thanapatay Dusit, Chaiwat S. ECG Beat Classification Method For ECG Printout With Principle Components Analysis and Support Vector Machines. *International Conference on Electronics and Information Engineering (ICEIC)*, 1:72–75, 2010.
- [35] Vaish Abhishek Dr. Performance Analysis Of Machine Learning Algorithms For Emotion State Recognition Through Physiological Signal. *Global Journal of Computer Science and Technology Neural and Artificial Intelligence*, 12, 2012.
- [36] Wilcoxon, Frank. *Individual Comparisons By Ranking Methods*.
- [37] Zellmer Erik, Fei Shang. Highly Accurate ECG Beat Classification Based On Continuous Wavelet Transformation And Multiple Support Vector Machine Classifiers. *IEEE*, 978-1-4244-4134-1, 2009.

A Generic Context-Aware Recommender Framework for M-commerce

Abdullah ABDULLAH^{a,1}, Xining LI^a

^a*School of Computer Science, University of Guelph, Canada*

Abstract. In this paper, we propose a generic Context Aware Recommendation framework for M-commerce applications. The core of the framework is a Multi-dimensional Contextual graph which can effectively represent various real-world objects and their relations. Once the graph is created, a Random Walk algorithm is applied to obtain a top-k recommendation list. Both products and services can be flexibly modeled into the framework, in addition to their related information such as ratings and QoS measures. As part of our ongoing work, the framework is aimed at presenting a comprehensive recommendation framework for Mobile users.

Keywords. M-commerce, Recommender systems, Random Walk

Introduction

Recent advances in wireless network technology offer new opportunities to better help nomadic users engage in various time-critical, goal-driven tasks. In fact, advances in hardware include various mobile devices such as tablets, mobile phones, smart phones, PDAs and Pocket PCs. On software side, accompanying all these mobile devices are different operating systems such as iOS, Android, Windows mobile. In telecommunication networks, there are several technologies including Wi-Fi, Bluetooth, infrared, GPRS, 3G and nowadays LTE/4G technologies [1][2]. As business is always at the top list of targets in our life, both industrials and researchers have been trying to develop business models that exploit these advances to better serve mobile users. As a result, a new business model has been emerged, called M-commerce. The model allows nomadic customers to explore, directly or indirectly, a complete commercial transaction using a mobile device [3]. In other words, it realizes the concept of anywhere/anytime business. Due to the wide spread of mobile devices and accompanying changes in customer behaviors, M-commerce is expected to grow incredibly in the next few years [4]. Different M-commerce applications have been recently appeared in the market; for instance, *mobile advertising*, *mobile couponing*, *mobile bargain hunting*, *mobile ticketing*, *mobile banking*, *mobile marketing and mobile auctioning*, etc. [5]. The main features of M-commerce are mobility, person-

¹Corresponding Author: Abdullah Abdullah, School of Computer Science, University of Guelph, Guelph, Canada, N1G 2W1; E-mail: aabdulla@uoguelph.ca.

ality, and flexibility, which make it more likely to become a major business model in near future.

Despite the promising future of M-commerce, the model still needs to overcome some critical limitations. Mobile handheld devices have different physical constraints such as small screen size, inconvenient input, poor network connectivity, limited battery capacity, besides limited storage and computing capabilities [6]. However some of these limitations are expected to diminish due to ongoing developments in both wireless and mobile devices technologies. In comparison with traditional desktop-based E-commerce applications, M-commerce applications can not adopt client/server E-commerce model. In this model, stable connectivity, transferring huge amounts of data and limited customer opportunities are considered main characteristics [7]. Specifically, due to the nature of mobile networks, it is nearly impossible to maintain a long and stable connection between a client mobile user and a remote server. Furthermore, in a typical desktop E-commerce scenario, a user manually explores and navigates through different websites in order to seek a better deal. Such a search task usually takes a long time and includes transferring a huge amount of data between both parties. In addition, the ever increasing number of products and services being provided on the Internet makes a commercial search task non trivial. Moreover, having different retailers provide their services on heterogeneous network platforms adds another burden in this context. Therefore, a sound M-commerce system must effectively overcome these obstacles.

On the other hand, personalization is another important feature that users increasingly require when seeking for a product or a service on the Internet. In many situations, a user may prefer to consult others opinions on a specific item to purchase or a place to visit, especially when he has no previous knowledge about. Another example is when a user seeks for the closest pizza shop that his friends recommend and so on. These and similar cases are usually handled by E-commerce recommender systems that exploit context-awareness. In the past few years, there have been several successful recommender systems designed for recommending specific types of items such as Netflix for movies, last.fm for songs and so on. On the context-aware recommender side, location based services (LBSs) are common examples. The idea is how a location context could be utilized when recommending places such as Museum and Tourist E-guides. Other contextual information may include any other social or physical information such as age, address, time-of-day, tastes, mobile device system etc. Recently, many context-aware recommender systems have been implemented. For example, Proximo [8] is a location-aware recommender system that shows museums and art galleries on a map in a user mobile device. Some researchers have focused on improving classical collaborative filtering algorithms, taking into account user contextual information [9]. Other frameworks used a reduction approach to convert a multidimensional contextual space into a traditional 2-dimensional one. Then classical recommendation methods can be easily applied to the reduced space [10]. Although, there are several context aware recommender systems in reality, it is still requires a lot of effort to design and build reliable and generic ones suitable for M-commerce applications.

In this paper, we propose a Generic Context-aware M-commerce Recommender System. Within different stages, the system utilizes various contextual information in order to provide a personalized list of recommendations to end user. At the end, the system can generate a user agent that can conduct a commercial transaction, on behalf, based on a user recommendation query. In fact, the system is generic in terms of types of recom-

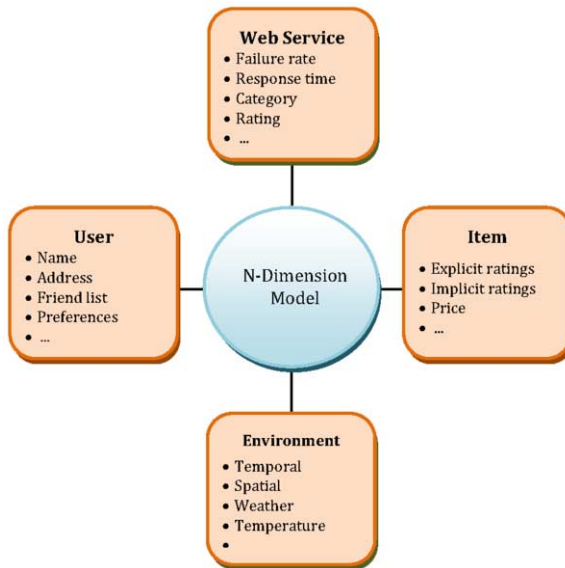

Figure 1. N-Dimensional Context Aware Model

mentation it can provide, types of objects it can recommend and types of contextual information it can handle. In other words, it can flexibly perform several recommendation approaches such as collaborative filtering, content-based filtering and etc. In terms of objects, it can recommend items such as movies and songs, as well as web services such as car rental and pizza ordering services. Finally, the contextual information, it handles, can be related to user profile, mobility conditions, user interaction history and even QoS of web services. The rest of the paper is organized as follows. Section 1 introduces the proposed M-commerce recommendation framework. Section 2 gives the problem formulation. In section 3 we describe how the contextual graph is created. Section 3.1 presents a Random Walk over the created graph. We conclude in Section 4.

1. Overview of the Proposed Framework

As we mentioned above, our goal is to design a generic recommendation framework for M-commerce. The framework should flexibly represent various dimensions of information related to different objects such as Users, Products or Items, and Web services, in addition to the working environment. In Figure 1, the main objects and some of their related information are illustrated. Due to this variety, such a framework must employ an effective multidimensional information model. Moreover, the model should not only ease information representation but also its processing.

A classical recommender system only deals with two dimensional space, i.e. User \times Item. However, in M-commerce, there is a necessity to incorporate other important dimensions such as time and location, etc. Therefore, in this work we propose a generic contextual recommendation framework that not only represents multidimensional infor-

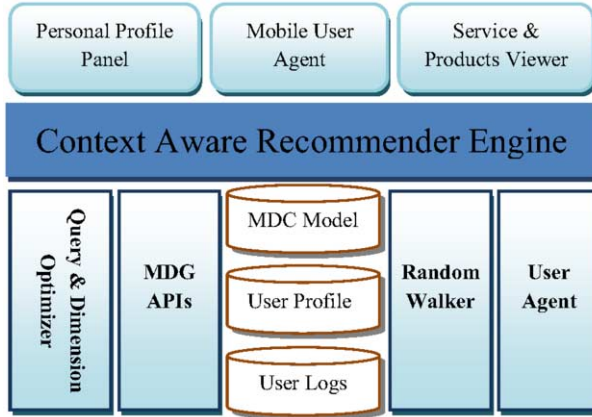

Figure 2. Context Aware Recommender for M-commerce

mation, but also responds flexibly and effectively to various mobile user M-commerce queries.

Imagine an M-commerce recommender system that can recommend different commercial transactions such as ordering items, renting, bidding, etc. Moreover, these transactions work on various items such as, books, cars, airline tickets, movies, songs, pizza and so on. In other words, the system ideally behaves as a broker between a mobile user and several commercial corporations that have electronic service portals, i.e. web services.

Figure 2 shows an overview of our framework. The core of the framework is a Multidimensional Contextual (MDC) graph structure, in which vertices and edges represent several objects and relationships respectively. For example, a vertex can represent a particular User, Movie or Web service, while a rating of a movie, number of accesses by a User for a Web service, or a friendship between two users can all be represented as edges. Other storage structures include User profile repositories and history logs. In the former, personal user information such as name, address, current location, list of preferences are stored; while in the later, user-system interactions are recorded. On the other hand, the framework contains four modules: *Query and Dimension optimizer*, *MDG APIs*, *Random walker* and *Interface user agent*. After receiving a mobile user query, Query and Dimension optimizer starts by analyzing it to extract a set of parameters necessary for later recommendations. For example, it can determine what information from user profile is required to be considered such as current location or permanent address. Since the framework is generic, it also determines the targeted dimensions according to users query. For instance, if a user is asking for recommending a car rental service, then the recommender should only consider objects such as User, Web service and their relations. That means there is no need to include a Movie object. This approach optimizes the recommendation process in terms of time and space, besides elevating accuracy level.

The next module is called MDC graph APIs. In this code module, a set of APIs are provided to create and maintain the graph. That includes add/remove/update operations on both vertices and edges. For instance, the system may perform a tour on the graph to infer friendship relations among users and then insert them into the graph accordingly.

Another example is when a user adds a new friend to his list or rate a particular item. Other APIs operate on sub-graphs. For instance, if a user requests a recommendation for movies, a certain API will initially construct the required MDC graph by concatenating two sub-graphs: User-User and Movie-Movie in a particular way, as we will explain in section 3. There could be also a certain API function responsible for setting up an initial query vector.

Once a MDC graph is created based on a user query, a Random Walk algorithm is performed, as it will be presented in section 3.1. The result of the Random Walker is a list of top-k recommendations according to users needs. In fact, it is possible to run the Random walker several time and with different parameters in order to fulfill different recommendation approaches. It is also possible to aggregate the results of several walks over the graph in order to obtain better results. Finally, the interface agent is responsible to communicate with user whenever he is online. Another possibility is to let the agent to call the recommended web service(s) on behalf of the user and then communicate the results. To maintain a higher privacy level, the agent can be sent to users mobile device, where it will be executed interactively as a set of web service calls.

In fact, the design of data structure, in which various contextual information are represented, is crucial to recommender systems. Therefore, in this paper, our main focus is on presenting a Contextual Graph-based model as a core part of the whole framework.

2. Problem Formulation

In this section, we define a Multi-Dimensional Contextual (MDC) graph which represents the core of our framework. Then, we give a definition of a Random Walk approach for computing Top-k recommendations for a given User Query.

Definition 1 (Multi-Dimensional Contextual Graph). A Multi-Dimensional Contextual Graph is defined as an undirected graph $G = (V, E)$, where V is a finite set of nodes obtained as the union of Ω sets such as $V = V_1 \cup V_2 \cup V_3 \cup \dots \cup V_\Omega$, $E \subseteq V \times V$ is a finite multi-set of edges. Each subset of V such as V_1 represents a particular type of vertices in the graph, for example V_1 is a User set, V_2 is an Item set, V_3 is a Location set, V_4 is a QoS set for Web services and so on. Let N be equal to $|V|$, the number of nodes in G .

In a movie recommendation task, various kinds of entities, such as USER, MOVIE, ACTOR, TAG, GENRE, TIME, can be modeled as different types of nodes in G . Specifically, V here is defined as $V = U \cup M \cup A \cup T \cup G$, where U is a set of users, M is a set on movies, A is a set of actors, T is a set of tags and G is a set of genres. All these information have been previously recorded into the system. Figure 3 illustrates a sample graph.

On the other hand, each edge in E corresponds to a link between two different nodes in G , connecting two nodes i and j with each other. Moreover, each edge has a weight value that represents not only the existence of relationship between both nodes but also its strength. For instance, for a user i and a movie j , there are two types of relations either an implicit binary usage patterns (seen vs. unseen) or a rating value such as from 1 to 5. Some entities may need another implicit way to capture their relation. For example in a Song listening service, a user may listen to a song multiple times. Therefore, an implicit usage pattern here can be represented by the number of listening times. Moreover, some edges are intuitively unweighted such as the one between a movie and an actor that he

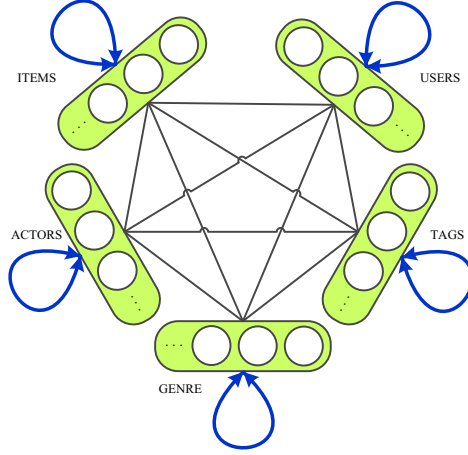

Figure 3. Multipartite graph for movie recommendation, showing five sub-graphs, their relations and self-transition links.

played in. In a generic recommendation system, the variety of relations between different types of entities must be effectively handled. Therefore, in our model we apply a normalization step in order to initially prepare the graph for further search processing. By including different contextual dimensions, our model utilizes not only the classical links between users and items, such as in collaborative filtering, but also links between other contextual entities modeled in the same graph.

Based on the definition of our Multi-Dimensional Contextual Graph, we now define the recommendation problem. Given a user recommendation query as a set of query nodes, we introduce the recommendation problem as a node ranking approach, based on common Random Walk algorithm over the graph.

Definition 2 (MDC graph-based Top-k Recommendation). For a given Multi-Dimensional Contextual Graph $G = (V, E)$, a recommendation query is given as $Q = (S, D_t, k)$, where S is a set of query nodes such as $S = \{q_1, \dots, q_{|S|}\} \subseteq V$, D_t is the target dimension and k is the number of recommended items for the query. The query node set S lists user provided information for his recommendation, while the target dimension D_t represents the type of nodes that the user is asking for. Now let Ψ be the set of all possible query node set S and Let V_t be the set of all target dimensions nodes $v \in V$. Now let $u : \Psi \times V_t \rightarrow R$ be a utility function that compute the benefit of target dimension nodes for a given query and R is a totally ordered set. For a given recommendation query $Q = (S, D_t, k)$, nodes $v \in V$ with the top-k highest utility scores $u(Q, v)$ are the final recommendation results.

The above formulation of our proposed recommendation approach provides a high level of flexibility in real-world recommendation environment. For instance, the traditional collaborative filtering recommendation problem of recommending items to users can be easily performed. Given a user $u \in U$, where U and I are the only dimensions under consideration, a query $Q = (S\{u\}, I, 10)$, and D_t is I , the results are the top 10 candidate items for the user u . Another possibility is to recommend to multiple users at a time. In this case, the query Q will be $Q = (S\{u_1, \dots, u_n\}, I, 10)$, where $u_1, \dots, u_n \in U$. When

other contextual dimensions, such as location and weather, are required to be considered during a recommendation process, a query Q can be formed as $Q = (S\{u, l, w\}, I, 10)$, where $l \in L$ and $w \in W$ (i.e. Location and Weather dimensions respectively).

3. Construction of MDC Graph

A random walk over G is a stochastic process in which the initial state is known, while the next state S is provided by a probability distribution [11] [12]. For our graph-based model, the distribution can be represented by constructing the transition probability matrix A , where the value of $A_{i,j}$ is the probability of moving from node i (at time n) to node j (at time $n+1$) as in the following:

$$A_{i,j} = P(S_{n+1} = j | S_n = i) \quad (1)$$

To illustrate how a transition matrix is created, we show a sample matrix that represents a multipartite network for a movie recommendation task, as in Figure 4. A complete transition matrix is initially created from a number of sub-matrices, each of which represents an individual entity such as Items, Movies, or Actors. In fact, the size of the matrix totally depends on how many entities involved in a recommendation process. For example, traditional collaborative filtering can be performed by only considering Users and Items, which results in a bipartite network. That means only two sub-matrices are needed to create the overall transition matrix. If a user wants to only consider a particular Actor in his query, then a tripartite network will be created from three sub-matrices and so on. Due to the high volume of raw recommendation data, a generic recommendation system should be able to provide a variety of recommendations by efficiently considering only related entities or dimensions.

Different types of weights in our multipartite network can be easily modeled in a corresponding transition matrix A . For instance, User-Movie sub-matrix contains ratings on a scale from 1 to 5; while tag counts for each user are stored in a User-Tag sub-matrix. On the other hand, edges in a Movie-Actor sub-network are represented as unary values, i.e. each actor j in a movie i is represented in the sub-matrix MA as $MA_{i,j} = 1$. After preparing all sub-matrices, we create the corresponding transposition sub-matrices. In order to conform to the following Random Walk search, the next step is to row-normalize all matrices. Given all sub-matrices and their transpositions, the transition probability matrix A can be created.

To allow the walk to stay in place, we add self-transition sub-matrices, i.e. identity matrices, to A . In Figure 4, User-User matrix, for instance, represents self-transition sub-matrix of all users. To control the effect of self-transition feature, a certain probability α is applied to all self-transition sub-matrices. Since A is initially designed to be a transition probability matrix, the final step is to row-normalize it. Therefore, all non-self-transition sub-matrices are row-normalized by the factor β :

$$\beta = \frac{1 - \alpha}{\delta - 1} \quad (2)$$

Where δ is the number of dimensions (i.e., the number of disjoint sets of entities or nodes). For example, in case of User, Movie, and Actor recommendation, δ is equal to 3.

	U	I	T	G	A
U	$\alpha * UU$	$\alpha * UI$	$\alpha * UT$	$\frac{(1-\alpha)*1}{4*} UG$	$\frac{(1-\alpha)*1}{4*} UA$
I	$\frac{(1-\alpha)*1}{4*} UI^T$	$\alpha * II$	$\frac{(1-\alpha)*1}{4*} IT$	$\frac{(1-\alpha)*1}{4*} IG$	$\frac{(1-\alpha)*1}{4*} IA$
T	$\frac{(1-\alpha)*1}{4*} UT^T$	$\frac{(1-\alpha)*1}{4*} IT^T$	$\alpha * TT$	$\frac{(1-\alpha)*1}{4*} TG$	$\frac{(1-\alpha)*1}{4*} TA$
G	$\frac{(1-\alpha)*1}{4*} UG^T$	$\frac{(1-\alpha)*1}{4*} IG^T$	$\frac{(1-\alpha)*1}{4*} TG^T$	$\alpha * GG$	$\frac{(1-\alpha)*1}{4*} GA$
A	$\frac{(1-\alpha)*1}{4*} UA^T$	$\frac{(1-\alpha)*1}{4*} IA^T$	$\frac{(1-\alpha)*1}{4*} TA^T$	$\frac{(1-\alpha)*1}{4*} GA^T$	$\alpha * AA$

Figure 4. A transition matrix for a movie multipartite network. UI sub-matrix contains user ratings, while UT and IT sub-matrices contain tag counts per user and per item respectively. All other sub-matrices are unary. Self-transition α is captured in UU, II, TT, GG, and AA sub-matrices. $\beta = \frac{1-\alpha}{4}$.

If user location dimension is added to the recommendation task, then δ becomes 4 and so on. This step ensures that all rows sum to 1. The size of A is significantly depends on how many dimensions, the system is dealing with, and the size of each. Therefore, given the number of dimensions δ provided by the system, and the number of elements in each dimension dn_i , such as the number of users and the number of movies, a dimension n of the square probability transition matrix $A_{n,n}$ can be calculated as:

$$n = \sum_{i=1}^{\delta} dn_i \quad (3)$$

The above multipartite model provides a flexible approach to include different types of dimensions (i.e., contexts) in various recommendation scenarios. By determining which dimensions are necessary for a current recommendation query, the system can utilize the transition probability matrix accordingly. However, major implementation issues face such a flexible context recommendation system in terms of scalability and performance, besides classical recommendation ones such as recommendation accuracy.

3.1. Random Walk over MDC Graph

Random Walk over a multipartite graph is a multistep approach that simulates navigating process from one part of the graph to another [12]. For instance, over a User-Item bipartite graph, the first step of a Random walk is to move from a set of User nodes to the corresponding set of Item nodes. Given a particular user initially selected, the result would be a new probability distribution over Items. The following is a pseudo code for a Random Walk algorithm:

Algorithm 1 Top-k Random Walk over MDCG

Input:

- $A_{n,n}$, a transition probability matrix.
- v_0 , an initial state query vector.
- N , a number of iterations or steps.
- k , a number of top recommendations required.

Output:

- v_N , the final state vector.

Procedure:

- 1: $t = 1$
 - 2: **repeat**
 - 3: Walk one step ahead
 - 4: $t = t + 1$
 - 5: **until** ($t = N$ **or** $v_\infty = v_\infty \times A_{n,n}$)
 - 6: Remove user already rated nodes
 - 7: Sort v_t in descending order
 - 8: Select Top-k elements
-

In Algorithm 1, the first input component is $A_{n,n}$, a complete row-normalized transition probability matrix. The second is an initial state query vector v_0 , which indicates user(s) selected to start the walk by setting the corresponding elements. As the vector is probability based, the following condition must apply:

$$\sum_{i=1}^n v_{0i} = 1 \quad (4)$$

The third variable of the input is N , which equals to how many steps are required. Two settings are available, manual and automatic. For the first, the system initially determined the value of N , while in automatic mode the walk continues until a convergence state is reached. The last parameter k means how many recommendations are required from the system. The algorithm then computes the next state vector by multiplying the previous one with the initial transition matrix, until the break condition is met. At the end and after t steps, the final state vector v_t will contain a new probability distribution over the original graph. After removing the items already rated by the user, we rank the resulted probabilities which considered final recommendations.

Note that, any combinations of several types of nodes can be included as query nodes in the state query vector v_0 . This can be achieved by assigning different weights, between $[0, 1]$, to each particular node, while they still sum up to one, as in Eq. (4). Therefore, various user requirements can be flexibly formed as queries for different recommendation tasks. Once the model is created, multiple recommendation scenarios could be easily applied. For instance, it is possible to recommend interesting new actors to the user by extracting their probabilities from the final vector v_0 , i.e. User \rightarrow Actor. Another recommendation task could be to retrieve a list of movies based on a certain actor(s) instead of a particular user. This refers to Actor \rightarrow Movie. Another interesting application is to provide a movie recommendation for a group of users such as friends at the same time. This could be achieved by activating all their corresponding elements in v_0 , either with equal or different weights. This represents User* \rightarrow Movie scenario.

4. Conclusion and Future Works

In this paper, we presented a generic Context Aware Recommendation framework for M-commerce applications. Its core is a Multidimensional Contextual graph. The graph can effectively represent various real-world objects and their relations. To get top-k recommendations, a Random Walk algorithm is then applied. In fact, the framework is generic in terms of types of recommendation, objects and contextual information it can handle. It is designed to flexibly perform several recommendation approaches such as collaborative filtering, content-based filtering and hybrid approaches. In terms of objects, it can recommend items such as movies and songs, as well as web services such as car rental and pizza ordering services. Finally, the contextual information include user profile, mobility conditions, user interaction history and even QoS of web services, etc. The framework is part of an ongoing work which is aimed at presenting a comprehensive recommendation framework for Mobile users.

References

- [1] S. Dekleva, J. Shim, U. Varshney, and G. Knoerzer, "Evolution and emerging issues in mobile wireless networks," *Commun. ACM*, vol. 50, pp. 38–43, June 2007.
- [2] N. M. Sadeh, *M-Commerce: Technologies, Services, and Business Models*. New York, NY, USA: John Wiley & Sons, Inc., 2002.
- [3] L. Bai, D. C. Chou, D. C. Yen, and B. Lin, "Mobile commerce: its market analyses," *Int. J. Mob. Commun.*, vol. 3, pp. 66–81, Dec. 2005.
- [4] J. Ankeny, "eMarketer: M-commerce sales leaped 81% in 2012." *Free Mobile Content Daily Newsletter*, 2013. <http://www.fiercemobilecontent.com/>; retrieved March 2013.
- [5] E. Ngai and A. Gunasekaran, "A review for mobile commerce research and applications," *Decision Support Systems*, vol. 43, no. 1, pp. 3 – 15, 2007.
- [6] R. Kowalczyk, P. Braun, I. Mueller, W. Rossak, B. Franczyk, and A. Speck, "Deploying mobile and intelligent agents in interconnected e-marketplaces," *Journal of Integrated Design and Process Science*, vol. 7, pp. 109–123, Aug. 2003.
- [7] W. Qiang and H. K. P. Hin, "Agent-based system for mobile commerce," in *Proceedings of the 16th International Parallel and Distributed Processing Symposium, IPDPS '02*, (Washington, DC, USA), pp. 56–, IEEE Computer Society, 2002.
- [8] E. Parle and A. Quigley, "Proximo, location-aware collaborative recommender," *School of Computer Science and Informatics, University College Dublin Ireland*, pp. 1251–1253, 2006.
- [9] G. Adomavicius and A. Tuzhilin, "Toward the next generation of recommender systems: a survey of the state-of-the-art and possible extensions," *Knowledge and Data Engineering, IEEE Transactions on*, vol. 17, no. 6, pp. 734–749, 2005.
- [10] B. Sarwar, G. Karypis, J. Konstan, and J. Riedl, "Item-based collaborative filtering recommendation algorithms," in *Proceedings of the 10th international conference on World Wide Web, WWW '01*, (New York, NY, USA), pp. 285–295, ACM, 2001.
- [11] M. Clements, A. P. de Vries, and M. J. Reinders, "Optimizing single term queries using a personalized markov random walk over the social graph," in *Workshop on Exploiting Semantic Annotations in Information Retrieval (ESAIR)*, 2008.
- [12] T. Bogers, "Movie recommendation using random walks over the contextual graph," in *CARS'10: Proceedings of the 2nd workshop on context-aware recommender systems*, 2010.

Towards a Component-based Design of Adaptive, Context-sensitive Services for Ubiquitous Systems

Tomás Ruiz-López^a, Carlos Rodríguez-Domínguez^a, Manuel Noguera^a,
María José Rodríguez^a and José Luis Garrido^a

^a*Software Engineering Department, University of Granada
Periodista Daniel Saucedo Aranda s/n, 18.071 Granada, Spain*

Abstract. Service design in the scope of Ubiquitous and Ambient Intelligence Systems is a complex task given the characteristics and requirements that must be usually addressed, and consequently the number of design decisions that need to be made. Existing methodologies provide guidance to this process from a general-purpose point of view, lacking support for specific features of this paradigm. In this paper, a novel approach to design dynamic, runtime adaptive services based on context information, called SCUBI, is proposed. It consists of a metamodel and a method to design services in terms of components, addressing the special characteristics of Ubiquitous Computing. The proposal is illustrated and validated through a case study of the design of a positioning service.

Keywords. SOA, components, context-awareness, ami, adaptation

1. Introduction

Design of services for Ubiquitous Computing is a difficult task given the number of decisions that need to be made. It typically involves the difficulties of designing services in the scope of Service-Oriented Architectures (SOA) [7], in addition to the challenges of designing and building adaptive [6] and context-aware systems [2].

Current approaches to the design of services [1,9] lack support to the specific features of Ubiquitous Computing (context-awareness, dynamicity, heterogeneity, etc.) [12], and provide general guidelines that usually are not enough for this paradigm. Although some approaches exist in the field of Ubiquitous Computing, they mainly focus on certain specific aspects, like the semantic definition of services [10] or the modeling of context [14], instead of providing a complete methodological support to the design process.

To try to address these shortcomings, in this paper, a Service Component design method for Ubiquitous Systems (SCUBI), together with a metamodel, is presented. It stems from our previous work in the Requirements Engineering stage with the proposal of a method to systematically deal with Non-Functional Requirements (NFR), called REUBI. The design method to be introduced in this paper aims to benefit from the results of the application of REUBI to derive a design model which meets the requirements. Nevertheless, it can be applied together with other requirements analysis techniques to

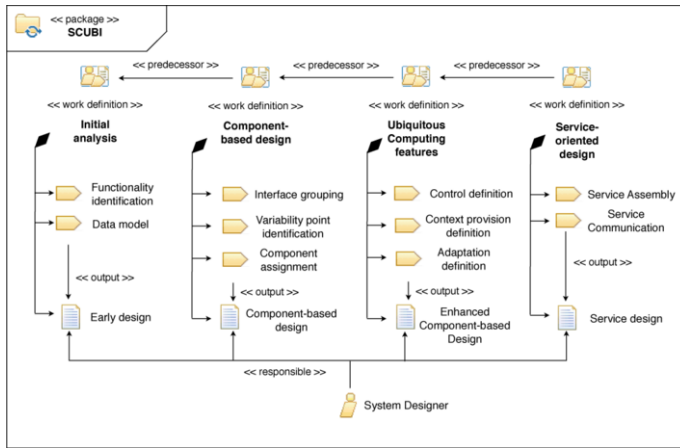

Figure 1. Summary of the stages of in the application of the SCUBI method, depicted as a SPEM diagram.

produce service designs. The objective is to obtain a design for services in terms of interchangeable and reusable components. The main features of this method are:

- Bottom-up approach to identify basic components, group them into more complex units and assemble them into services.
- UML compliance.
- Promotion of reuse, not only at service level, but at component level, as individual pieces are created as basic blocks that follows the principles of Component-based Software Engineering.
- Enablement of control of service parts, either by humans or by software agents.
- Incorporation of context changes to alter the behavior and structure of the services and their parts.
- Fine and coarse-grained adaptation of services.

The rest of this paper is structured as follows. Section 2 presents the main core of the proposal, consisting of a Service Component design method for Ubiquitous Systems. The proposal is illustrated through the case study of a positioning service in Section 3, and compared to existing approaches in Section 4. Finally, conclusions of this work and possible trends for future work are outlined in Section 5.

2. SCUBI: a Service Component Design Method for Ubiquitous Systems

In this section, the core of the proposal is introduced. It consists of a Service Component Design Method for Ubiquitous Systems (SCUBI). Figure 1 summarizes the activities in the application of the SCUBI method. The process consists of four parts: identification of the main functionality of the system, elaboration of a component based design, enhancement of this design to address features of Ubiquitous Systems, and creation of services in terms of components. It is an iterative and incremental process. In the following sections, each of the stages is described thoroughly.

2.1. Functionality identification

The first step in the SCUBI method consists of the *identification of the functionality* that needs to be provided within the system. In this sense, this activity is tightly related to the previous stage in a development process; specifically it stems from the results of the Requirements Engineering stage.

To this end, SCUBI recommends to start this process with the application of our previous work, a Requirements Engineering method for Ubiquitous Systems (REUBI) [12]. This goal-based method already addresses some of the main features of Ubiquitous and AmI Systems and its output is suitable to be employed by this method.

However, alternative options can be applied to perform this task. For instance, designers can make use of UML Use cases since Ubiquitous Systems are user-centric in nature and they are a good means to communicate with stakeholders. Another possibility is the use of UML Collaboration and Sequence diagrams, in order to obtain a more technical description of the functionality. A combination of both approaches (use cases for early identification, collaboration/sequence diagrams for late elaboration) may be the most suitable option.

The output of this stage should be a technical specification of the functionalities in terms of method signatures. It may be difficult to obtain a complete set of functionalities; therefore, designers should follow an iterative and augmentative refining process to complete this stage.

2.2. Data model

The other entry point to this method consists of the elaboration of a data model. This task is suitable to be performed in parallel to the previous task, as the discovery of new classes and datatypes may trigger the need of additional functionalities, and vice versa.

At the same time, this task can be divided into two subtasks. In the early iterations of this stage, the aim is to build an initial model of the datatypes that are needed in the system, what is oftentimes known as domain model. This model should be expressed in terms of a UML Class diagram.

Later in the development process, the domain model can be incrementally and iteratively refined with the incorporation of fine-grained information, such as the attributes of each class, in order to further describe the informational needs of the model.

The data model elaborated in this stage helps to eventually group functionalities into different interfaces, and ultimately, discover the necessary components and services, as exposed in the following sections.

2.3. Interface grouping

Once these functionalities have been identified, they need to be grouped into different interfaces in order to be assigned to components in later stages. The SCUBI metamodel (Figure 2) distinguishes three types of interfaces:

- **Functional interface:** contains a set of functionalities that can be exposed or invoked by a component or a service.
- **Control interface:** contains a set of methods to control a component or a service and alter its behavior (further details on Section 2.6).

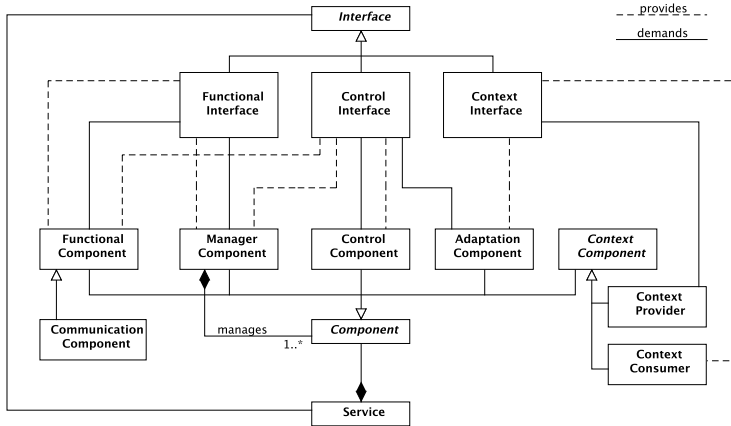

Figure 2. SCUBI Service Metamodel. For the sake of clarity, dashed lines between components and interfaces indicate interface provisioning, whereas full lines indicate interface demand.

- **Context interface:** contains a set of methods to exchange contextual information between a component or a service (further details on Section 2.7).

In this stage, the main focus is in the former. Functionalities, expressed in terms of methods, need to be grouped into functional interfaces according to some criterion. Typically, this task is done following the principles of the separation of concerns stated in the paradigm of Component-based Design. Some criteria to perform this grouping include the following:

- **Data-driven grouping:** operations dealing with the same set of data are subject to be grouped within the same interface. It oftentimes involves the presence of CRUD operations (*Create, Retrieve, Update, Delete*) over a certain datatype.
- **Use case-driven grouping:** operations involved in the same use case or performed by the same actor are subject to be included together in the same interface.
- **Category-driven grouping:** operations with the same purpose or intent (e.g. perform authentication of a user) may result included in the same interface.
- **NFR-driven grouping:** operations whose execution is intended to improve a certain NFR (e.g. improve security) are candidates to be included in the same interface.

At this point, designers have a set of interfaces modeling abstract behaviors within and exposed by the system.

2.4. Variability point identification

The heterogeneity of alternatives, specially from a technological viewpoint, existing in ubiquitous environments, each of them with different quality properties, makes difficult the adoption of a single option to perform certain tasks.

Moreover, a key feature of ubiquitous applications is the ability to react and adapt upon changes in the environment. In this regard, the possible variation points need to be

identified. A *variability point* is an interface in the design where multiple alternatives are possible to support a set of requirements, either functional or non-functional. This is the purpose of this task; given the set of identified interfaces modeling abstract behaviors, designers must select those that can accept different implementations with certain variations.

There are some criteria to help the discovery of the variability points. As a set of possible guidelines to their identification is composed of the following:

- **Sensing and actuation:** sensors and actuators are key devices in the scope of Ubiquitous Computing. Given the number of technological manufacturers and existing alternatives that can be found, is difficult to choose just one for a certain system. Thus, an interface modeling the behavior of this devices is a potential variability point.
- **User interaction:** Ubiquitous Computing claims the use of natural interfaces to interact with the system. Depending of the circumstances, numerous alternatives are possible, such as speech understanding and synthesis, or multimodal interaction. Interfaces modeling user interaction capabilities are subject to be variability points.
- **Information storage, provision and presentation:** in order to guarantee information persistence, storage mechanisms need to be incorporated. Depending on the storage capabilities of different devices, numerous alternatives exist, ranging from plain text to database management systems. Similarly, information can be retrieved and presented from different sources and in distinct ways (quantity, sorting, relevance, etc.)
- **Service communication:** there is a wide number of communication technologies, protocols or middleware solutions, which suggests that interfaces regarding communicational aspects are likely to be variability points.

2.5. Component assignment

The next step proposed by this method consists of an assignment of the identified interfaces to components that can implement them. In this regard, the SCUBI metamodel distinguishes different kinds of components:

- **Functional components:** these are the most basic components. They implement the functionalities expressed in the methods contained by interfaces. A specialization of these are *Communication components*, which implement functionalities by the remote invocation of operations in other devices. They can provide and demand several *functional interfaces*, and provide at most one *control interface*.
- **Control components:** they are intended to alter other components behavior by the application of certain actions on their structure (further details on Section 2.6). They can provide and demand *control interfaces*.
- **Context components:** their purpose is to deal with contextual changes. In this regard, two subtypes are distinguished: *Context providers*, which are sources of contextual information that may be useful for other entities in the system; and *Context consumers*, which are sinks of contextual information and use these data to eventually perform some actions based on them (further details on Section 2.7).

- **Adaptation components:** they aim to incorporate all the knowledge about adapting the structure of a service (further details on section 2.8). Adaptation components provide *context interfaces* and demand *control interfaces*.
- **Manager components:** they are aggregations of components, in such a way that they can select among different alternative components, or combine their results. They provide at most a *control interface*, and provide or demand different type of interfaces, depending on the components they contain.

The focus of this stage is centered on functional and manager components. Designers must take the identified functional interfaces and assign them to functional components that can provide them. It is important to note that each functional interface can be assigned to many functional components. It is up to the designers choice which of these components are suitable to be incorporated in the system. If REUBI has been applied previously in the development process, the evaluation procedure may have been useful to make this decision.

Afterwards, designers must consider the identified variability points. For each interface that has been marked as a variability point, a manager component must be created. This manager component both provide and demand such interface, and it acts as a proxy to the actual functional components that implement the corresponding functionalities. The responsibility of the manager component is to select among the alternatives or, combine their results, if possible. For this reason, designers need to decide how many functional components can be selected from the manager at the same time, as well as the procedure to combine results (e.g. join results, average, sum, etc.).

Another important aspect that must be considered in cases where multiple functional components can be selected is the interactions and side effects that may appear from this combination, from which can be distinguished [15] complementary (additional positive effects in the composition), orthogonal (no effects) or opposed (negative effects).

Finally, given the recursive structure, as depicted in Figure 2, the metamodel allows the creation of manager components in charge of selecting other manager components. This enables the possibility of changing the selection protocol to choose functional components, or the policy to combine their results.

2.6. Control definition

At this point, the design includes a set of interfaces that are implemented by a set of different components, and managed by higher level ones. The goal of this stage is to incorporate control mechanisms that can alter the behavior of each of these basic components.

In order to achieve this, control mechanisms need to be defined. In a first step, components that are subject to be controlled, i.e., those whose behavior or structure can be modified, are selected. For each one of them, a *control interface* must be defined. This interface needs to contain the necessary methods to indicate to the component the modifications that it accepts. Components with the same functional interface must share the same control interface in order to make their use as transparent as possible. *Manager components* must have a control interface, whereas *functional components* may or may not. In a second step, *control interfaces* must be assigned to *control components* which implement them.

Control may come from different sources. On the one hand, system managers can decide which functional components to select and fine tune them to address the needs of

the target deployment environment. On the other hand, it may come from other software units as a response to certain changes in the environment and the need to adapt to it to guarantee quality properties. This will be further discussed in the following sections.

2.7. Context provision definition

Context-awareness is a key feature of Ubiquitous Systems. For this reason, this stage aims to incorporate the influence of context on services to their design. In an initial step, designers must identify which contextual events [11] are relevant to the services and elaborate a small data model in terms of a UML Class diagram. If REUBI has been applied for the Requirements Engineering stage, designers already count on an initial context model which may be helpful to continue this task.

The next step consists of the definition of the corresponding *context interfaces* where contextual events will be notified. As a rule of thumb, a context interface should be created for each relevant event. If certain entities always respond to the same events, their corresponding interfaces can be merged into a single one to reduce their number.

Finally, these interfaces need to be implemented by components. As pointed in Section 2.5, *context components* can be either *providers* or *consumers*. For each context consumer, at least one context provider must exist. Context providers demand a context interface, whereas consumers provide it. Although it may look counter-intuitive, this is done in such a way that providers can invoke the methods of the consumer, making use of push-based notifications. If interfaces are assigned the other way around, it typically involved the adoption of a pull-based approach to check if there is a contextual change, which usually is not very efficient and can lead to the loss of some contextual changes.

2.8. Adaptation definition

Adaptation in Ubiquitous Computing consists of three steps: sensing the context, reasoning about the adaptation and performing the appropriate actions to modify the structure or behavior of the system, if any [6]. In the previous sections, the SCUBI method has considered how context is acquired, by means of context components, and how modifications in behavior or structure are applied, through control components.

In this step, *adaptation components* must be incorporated. An adaptation component provides, at least, a context interface, where it is notified when relevant context events occur. Also, it demands, at least, one control interface, where it can send a message to indicate the actions that need to be performed when an adaptation is triggered.

The design of this component depends on the complexity of the system. Designers must decide which techniques to be used among the available, ranging from rule-based techniques to case-based reasoning approaches. Each one of them presents different advantages and shortcomings; therefore, a careful study must be performed before making this decision.

Also, the granularity of the adaptation must be considered. The SCUBI method distinguishes two kinds of adaptations: fine-grained and coarse-grained. This is achieved by control interfaces and components. When the output of the adaptation process is directed to a control component in a functional component, we consider it a fine-grained adaptation, since it entails a concrete modification of a certain aspect of a component. On the other side, when control is applied to a manager component, we consider it to be

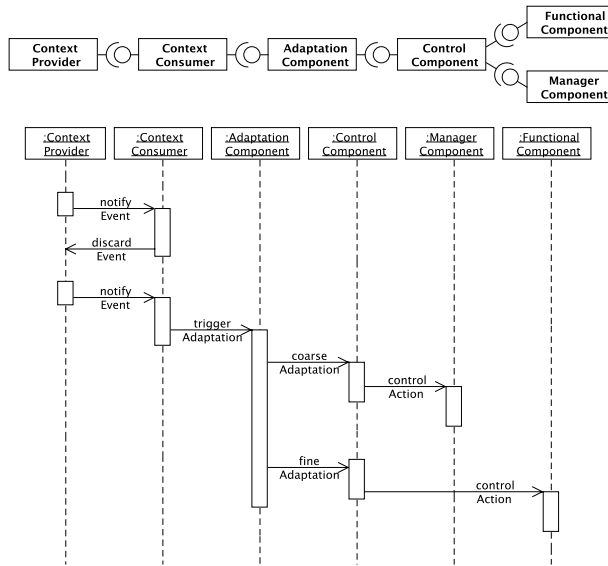

Figure 3. Component structure and interactions between them to perform an adaptation.

coarse-grained adaptation, because it usually involves addition, removal or substitution of other components.

Adaptation can occur at different times in the software lifecycle. SCUBI enables the possibility to adapt in design and deployment time, thanks to the use of compatible interfaces, but also in runtime, thanks to the incorporation of adaptation components.

A typical adaptation process in runtime is depicted in Figure 3, together with the component structure to carry out this task. When a contextual event happens, a context provider notifies the corresponding consumer. In this component, an initial filtering of this event is performed to discard irrelevant events. Then, the event is passed to the adaptation component, which triggers a reasoning process to decide which actions are necessary, if any. When a result has been obtained, it is indicated to the control component, which actually performs the corresponding actions on manager or functional components.

Finally, the actual adaptations need to be described. If the REUBI method has been applied previously, designers have a background about which variations are possible, when they have to be applied and how the application changes the system. Taking this information into account leads to the definition of adaptations.

2.9. Service assembly

When the basic components have been identified, they must be assembled into the corresponding services. Multiple assemblies are possible; for this reason, designers must take into account the characteristics of the Service-Oriented Architecture paradigm, such as separation of concerns, loose coupling or potential reuse of assets. Some of the criteria exposed in Section 2.3 can be used in this stage to group components into services.

Once services have been identified and built in terms of different components, the service interfaces must be defined. SCUBI services are subject to have the three types of

interfaces defined in Section 2.3. Designers must decide which of the internal interfaces provided by the components are going to be exposed as service interfaces, both for functional, control and context. In the simplest case, the service interface is the join of every component provided interfaces.

2.10. Service communication

Finally, when services have been identified, dependencies between them must be managed. Services need to communicate and coordinate with each other in order to perform some tasks. To this end, *communication components*, as described in Section 2.5, may be introduced in the service structure to deal with the aspects of discovery, coordination and communication between services.

Some important decisions need to be made in this stage. On the one hand, designers must decide how the coordination between services is going to be made. Different options, such as orchestration and choreography, are available. On the other hand, the discovery of services differs depending on the architectural style that is decided for SOA. Many alternatives are possible, such as matchmaking, broker-based or peer to peer [4]. In any case, these decisions should be encapsulated in the communication components, which can be easily replaced if the requirements change.

3. Case Study: Positioning Service

To illustrate the application of the SCUBI method, a case study of a positioning service has been chosen. The Requirements Engineering stage was shown in our previous work with the illustration of the REUBI method [12]. Therefore, this illustration stems from the results obtained during that requirements analysis to obtain the corresponding design for that service [13].

To begin the process, an initial discovery of the functionality and data model is performed. Regarding functionality, the main feature is *obtain a location*. If we elaborate on this a little further, in most cases it is necessary to *perform measurements* on signals and *compute a location* based on the received measurements. As for the datatypes, *measurements* and *locations* are the main entities that can be exchanged containing data.

The identified functionalities can be grouped into three functional interfaces, namely IPositioning, ISignalMeasurement and IPositionEstimation. Each one of them contain only a method performing the identified functionalities.

The next step consists of variability identification. According to the criteria exposed in Section 2.4, and the study of the bibliography related to positioning systems, many alternatives exist to perform signal measurements, as well as algorithms to estimate a position [13]. Thus, it entails that the last two interfaces can be marked as variability points. Also, since positioning can occur both indoors and outdoors, the IPositioning interface is a variability point.

Then, components are assigned to the corresponding interfaces. Three manager components are created to handle the variability points. To implement each interface, different functional components are introduced (Table 1).

The combination of indoor and outdoor positioning components is orthogonal, since there is no interaction between them. Their results can be combined by joining them.

Table 1. Summary of components and interfaces assigned.

Functional interface	Manager component	Functional Component	Comments
IPositioning	Positioning Manager	OutdoorPositioning, IndoorPositioning	Provides functionality to <i>obtain a location</i>
ISignal Measurement	Measurement Manager	WiFi, ZigBee, Bluetooth	Provides functionality to <i>perform measurements on signals.</i>
IPosition Estimation	Positioning Manager	k-NN, Probabilistic, NeuralNetworks	Provides functionality to <i>compute a location.</i>

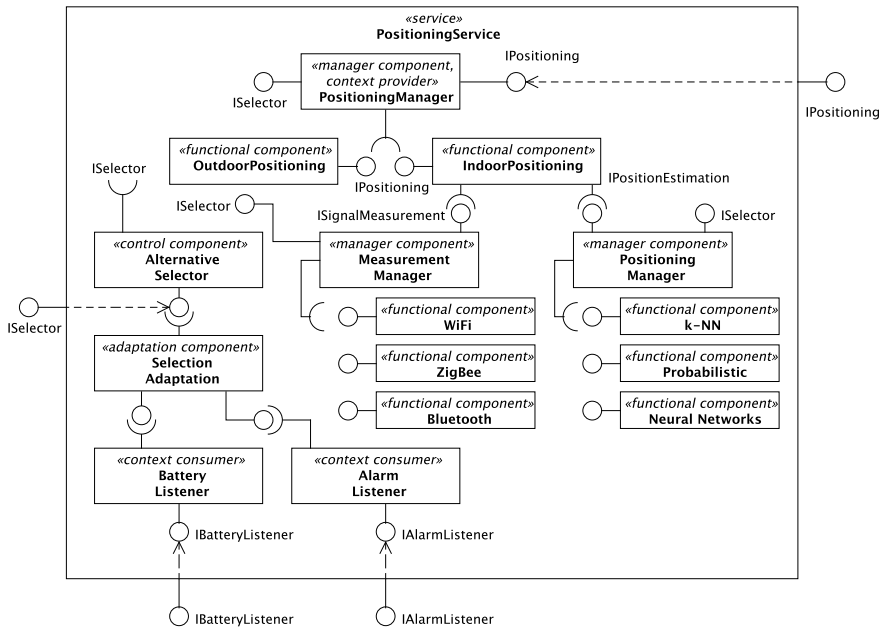

Figure 4. Assembly of different components into a positioning service.

Regarding the combination of signal measurement components, their interaction is complementary in the sense that employing more sources of data typically gives a higher accuracy and robustness for the system. Their results can be merged by joining them. Finally, the interactions among position estimation components can be different depending on the point of view; their combination is complementary in terms of improving the accuracy, but opposed in terms of degrading performance, since more computations need to be done. The policy to combine their results can be, for instance, the average between different results, weighted by the confidence on the position estimation algorithm.

For the sake of conciseness, control is only defined for manager components. A control interface, ISelector, is introduced. It only provides a method to specify which functional components are applied. It is implemented by a component, AlternativeSelector which gives the order to select among the alternatives.

Since location is an important feature of context, the IPositioning can be considered a context interface, and the components implementing it are context providers. At the

same time, according to the results of the requirements engineering stage, interesting contextual events include the activation of an alarm or the consumption of battery. To this end, the corresponding context consumers are incorporated.

Finally, all the identified components are assembled into a positioning service, as depicted in Figure 4.

4. Related Work

Several different methodologies for service analysis and design can be found on the bibliography [1] [9]. They aim to cover the whole lifecycle of service development, from specification to deployment. These approaches are general purpose and do not take into account the specific features of Ubiquitous Computing, such as context-awareness or adaptation, either during specification or design, as SCUBI does address. Moreover, the existing methodologies for SOA are broad and only provide certain guidelines about how to proceed in this process, as this paper has proposed.

Service Component Architecture (SCA) [3] is a software technology which aims to cover these problems by the provision of a framework that ease the composition of services by means of component interactions. This also lacks support of context-awareness and adaptation features that are necessary in the scope of our proposal. Some other approaches [5] are based in SCA with modifications to incorporate functional and structural interfaces. This approach is similar to what was exposed in the SCUBI method, where the structural interfaces correspond to control interfaces that enable fine-tuning of the structure of components. In this case, authors do not provide information about how adaptations are performed, and if context is addressed in this process.

Other works [10] focus on the semantic definition of services for AmI environments in OWL-S [8], with modifications to incorporate control interfaces to manage the NFR-related features of the services. SCUBI is intended to be applied after REUBI, which performs a systematic treatment of NFRs, and the adaptation mechanisms entail reconfiguration based on functional needs, but also to improve quality requirements. Finally, model-driven approaches exist [14], but are focused on detailed design from an implementation point of view. They provide details about how to deal with context, but focusing on context modeling and representation, rather than using it to adapt the service structure.

5. Conclusions and Future Work

This paper has proposed a new method to design services for Ubiquitous Systems following the principles of Component-based design, and incorporating mechanisms to support context-aware adaptation of such services.

Our contribution is twofold: on the one hand, SCUBI proposes a metamodel to indicate how services should be divided into different components, each one of them with a concrete, well-defined responsibility, allowing their reuse and exchange; on the other hand, a method is proposed to guide, step by step, in the process to design context-sensitive, adaptive systems. SCUBI aims to be applied after REUBI in order to take advantage of its benefits in the analysis of NFRs, and to incorporate them into the design

of services realizing the requirements. It also provides the benefits of the paradigms of Component-based Design and Service-Oriented Architecture, enhancing them to fulfill the needs of Ubiquitous Systems. The method provide guidance along the design process, but also leaves room to incorporate variations. Different techniques can be employed before the design, besides REUBI. Also, distinct context representations or reasoning techniques for adaptation, can be selected to be applied together this method.

Regarding future work, SCUBI and REUBI are part of a more general development methodology following the principles of model-driven engineering. In this respect, we are working on the elaboration of transformation rules to semi-automatically derive design models conforming the SCUBI metamodel, from requirements model conforming the REUBI metamodel. Besides that, SCUBI has been successfully applied to some developments, as the case study presented in this paper. However, more services have to be analyzed to study the advantages and drawbacks of the method and metamodel, and improve it to achieve quality-driven methodology to the development of Ubiquitous Systems.

References

- [1] A. Arsanjani: *Service-oriented modeling and architecture*, 2004. IBM developer works.
- [2] M. Baldauf, S. Dustdar, F. Rosenberg: *A Survey on Context-aware Systems*, 2007. International Journal of Ad Hoc and Ubiquitous Computing, vol. 2(4), pp. 263 – 277.
- [3] M. Beisiegel, H. Blohm, D. Booz, M. Edwards, O. Hurley, S. Ielceanu, A. Miller, A. Karmarkar, A. Malhotra, J. Marino: *SCA Service Component Architecture-assembly model specification*, 2007. Open Service Oriented Architecture.
- [4] T. Dillon, C. Wu, E. Chang: *Reference architectural styles for service-oriented computing*, 2007. Network and Parallel Computing, pp. 543 – 555.
- [5] V. Hourdin, J.Y. Tigli, S. Lavirotte, G. Rey, M. Riveill: *SLCA, Composite Services for Ubiquitous Computing*, 2008. Proc. of Int. Conference on Mobile Technology, Applications and Systems, pp. 11.
- [6] K. Kakousis, N. Paspallis, G. Papadopoulos: *A survey of software adaptation in mobile and ubiquitous computing*, 2010. Enterprise Information Systems, vol. 4(4), pp. 355 – 389.
- [7] C.M. MacKenzie, K. Laskey, F. McCabe, P.F. Brown, R. Metz, B.A. Hamilton: *Reference Model for Service Oriented Architecture 1.0*, 2006. OASIS Standard, vol. 12.
- [8] D. Martin, M. Burstein, J. Hobbs, O. Lassila, D. McDermott, S. McIlraith, S. Narayanan, M. Paolucci, B. Parsia, T. Payne: *OWL-S: Semantic markup for web services*, 2004. W3C Member submission, vol. 22.
- [9] M.P. Papazoglou, W.K. van den Heuvel: *Service-oriented design and development methodology*, 2006. International Journal of Web Engineering and Technology, vol. 2(4), pp. 412 – 442.
- [10] D. Preuveneers, Y. Berbers: *Semantic and syntactic modeling of component-based services for context-aware pervasive systems using OWL-S*, 2005. Proc. 1st Int. Workshop on Managing Context Information in Mobile and Pervasive Environments, pp. 30 – 39.
- [11] C. Rodríguez-Domínguez, K. Bengehazi, M. Noguera, M. Bermúdez-Edo, J.L. Garrido: *Dynamic ontology-based redefinition of events intended to support the communication of complex information in ubiquitous computing*, 2010. Network Protocols and Algorithms, vol. 2(3), pp. 85 – 99.
- [12] T. Ruiz-López, M. Noguera, M.J. Rodríguez, J.L. Garrido, L. Chung: *REUBI: a Requirements Engineering Method for Ubiquitous Systems*, 2012. Science of Computer Programming (in press).
- [13] T. Ruiz-López, C. Rodríguez-Domínguez, M. Noguera, J.L. Garrido: *Towards a Reusable Design of a Positioning System for AAL Environments*, 2012. Evaluating AAL Systems through Competitive Benchmarking, Indoor Localization and Tracking, pp. 65 – 70.
- [14] E. Serral, P. Valderas, V. Pelechano: *Towards the model driven development of context-aware pervasive systems*, 2010. Pervasive and Mobile Computing, vol. 6(2), pp. 254 – 280.
- [15] E. Wohlstadter, S. Tai, T. Mikalsen, I. Rouvellou, P. Devanbu: *GlueQoS: Middleware to sweeten quality-of-service policy interactions*, 2004. Proc. 26th Int. Conference on Software Engineering, pp. 189 – 199.

Extraction of Association Rules in between Socio-demographics and Biochemistry Datasets of Schizophrenia Patients using Multi-Objective Genetic Algorithms

Buket KAYA^a and İbrahim TÜRKOĞLU^b

^aOrganized Industry Area Vocational School of Mines, Fırat University, Elazığ, Turkey, bkaya@firat.edu.tr

^bDepartment of Software Engineering, Fırat University, Elazığ, Turkey

Abstract. This paper presents a method for extracting automatically association rules via multi-objective genetic algorithms. The paper also proposes a novel objective measure to quantify the comprehensibility of the rules. The other objectives of the rules are average support value and average confidence value. We experimentally evaluate our approach on socio-demographics and biochemistry datasets of schizophrenia patients and demonstrate that our algorithm encourages us to improve and apply this strategy in many real-world applications.

Keywords. Data Mining, Association Rules, Multi-Objective Genetic Algorithms

Introduction

The interest in medical decision-making has been gaining momentum in recent years. Nowadays enormous amounts of information are collected continuously by monitoring physiological parameters of patients. The growing amount of data has made manual analysis by medical experts a tedious task and sometimes impossible. Many hidden and potentially useful relationships may be not recognized by the analyst. The explosive growth of data requires an automated way to extract useful knowledge. One of the possible approaches to this problem is by means of data mining or knowledge discovery from databases.

Association rule mining is one of the most studied tasks in data mining community and is an active research area. Association rules are typically useful for medical problems which have been massively applied particularly in the area of medical diagnosis. Such rules can be verified by medical experts and may provide better understanding of the problem in-hand. Numerous techniques have been applied to association rule mining problem over the past few decades, such as Apriori, FP-growth, quantitative association rules and evolutionary algorithms [1-4]. Among these

approaches, evolutionary algorithms have been emerged as a promising technique in dealing with the increasing challenge of data mining in medical domain [4].

The paper proposes a novel method to extract automatically comprehensible association rules in a given database. For this purpose, more quality rules are found emphasizing on similarity, average support and average confidence. In doing so, multi-objective genetic algorithms are utilized. As apart from the studies in the literature [11-16], our method introduces a new comprehensibility concept and applies on database for extracting the effective association rules. The proposed method is validated upon socio-demographics and biochemistry datasets of Schizophrenia patients from Firat University Hospital. Experimental results show that our method produces comprehensible rules with high support and confidence value for the medical datasets.

The rest of the paper is organized as follows: Section 1 describes multi-objective optimization. Section 2 presents our multi-objective genetic algorithm based method for extracting association rules, including the encoding method, objectives, selection and genetic operators. In Section 3, we experimentally evaluate our approach. Finally, we conclude our work in Section 4.

1. Multi-Objective Optimization

Contrary to single objective optimization problem, multi-objective optimization problem deals with simultaneous optimization of several incommensurable and often competing objectives such as performance and cost. For example, when the design of a complex hardware is considered, it is required for the cost of such systems to be minimized while the maximum performance is expected. If there is more than one objective criterion as in the example mentioned above, some of them can be considered as constraints in the problem. For example, while trying to optimize a system for large performance in low cost, the size of the system must not exceed given dimensions as a separate optimization criterion. By this way, a multi-objective optimization problem can be formalized as follows [5]:

Definition 1: A multi-objective optimization problem includes, in general, a set of a parameters (called decision variables), a set of b objective functions, and a set of c constraints; objective functions and constraints are functions of the decision variables. The optimization goal is expressed as:

$$\begin{aligned} \min/\max \quad & y = f(x) = (f_1(x), f_2(x), \dots, f_b(x)) \\ \text{constraints} \quad & e(x) = (e_1(x), e_2(x), \dots, e_c(x)) \leq 0 \\ \text{where} \quad & x = (x_1, x_2, \dots, x_d) \in X \\ & y = (y_1, y_2, \dots, y_b) \in Y \end{aligned}$$

where x is the decision vector, y is the objective vector, X denotes the decision space, and Y is called the objective space; the constraints $e(x) \leq 0$ determine the set of feasible solutions.

Let us consider the above definition and assume that the two objectives performance (f_1) and cheapness (f_2), the inverse of cost, are to be maximized under size constraints (e_1). Then, an optimal design might be an architecture which achieves maximum performance at minimal cost and does not violate the size limitations. If such a solution exists, we actually only have to solve a single-objective optimization problem. The optimal solution for either objective is also the optimal for the other objective. However, what makes multi-objective optimization problems difficult is the common situation when individual optima corresponding to the distinct objective functions are sufficiently different.

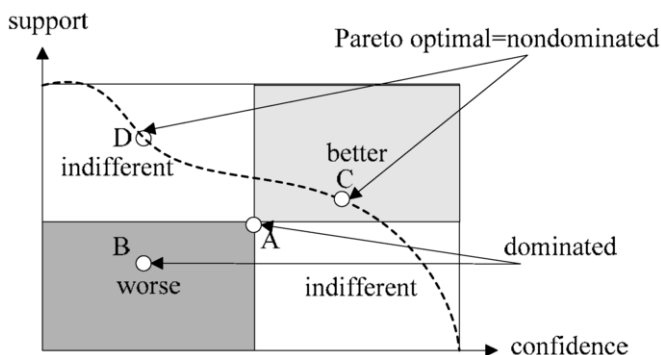

Figure 1. The concept of Pareto optimality

In Figure 1, we considered the values of support and confidence of fuzzy rules as objective functions. In this regard, a solution defined by corresponding decision vector can be *better* than, *worse*, or *equal* to, but also *indifferent* from another solution with respect to the objective values as shown in Figure 1. Better means a solution is not worse in any objective and at least better in one objective than another. For example, while the solution represented by point B is worse than the solution represented by point A, the solution with C is better than that of A. However, it cannot be said that C is better than D or vice versa. This is because one objective value of each point is higher than the other one. Using this concept, an optimal solution can be defined as: *a solution which is not dominated by any other solution in the search space*. Such a solution is called *Pareto optimal*, and the entire set of optimal trade-offs is called the *Pareto-optimal set*, which is represented as dotted line in Figure 1.

In such an optimization problem, the objectives are conflicting and cannot be optimized simultaneously. Instead a satisfactory trade-off has to be found. Therefore, it is necessary to have a decision making process in which preference information is used in selecting an appropriate trade-off.

2. Design of Sets of Rule Based on Multi-Objective Genetic Algorithms

A Genetic Algorithm (GA) is a search and optimization methodology from the field of evolutionary computation that was invented by Holland [6]. A GA is based on the Darwin's natural selection principle of the survival of the fittest, and is widely used for hard problems in engineering and computer science. A GA is a population-based method where each individual of the population represents a candidate solution for the target problem. This population of solutions is evolved throughout several generations, starting from a randomly generated one, in general. During each generation of the evolutionary process, each individual of the population is evaluated by a fitness function, which measures how good the solution represented by the individual is for the target problem. From a given generation to another, some parent individuals (usually those having the highest fitness) produce "offsprings", i.e., new individuals that inherit some features from their parents, whereas others (with low fitness) are discarded, following Darwin's principle of natural selection. The selection of the parents is based on a probabilistic process, biased by their fitness value. Following this procedure, it is expected that, on average, the fitness of the population will not decrease every consecutive generation. The generation of new offsprings, from the selected parents of the current generation, is accomplished by means of genetic operators. This process is iteratively repeated until a satisfactory solution is found or some stop criterion is reached, such as the maximum number of generations.

We use a well-known high-performance multi-objective genetic algorithm called NSGA II [7] to find a large number of a set of rules with respect to three objectives, which will be discussed in the objectives subsection.

2.1. Individuals Representation

Due to nature itself of the problem to solve, that is, the fact that the value of attributes are taken from continuous domain, we use real codification to represent the individuals. An individual in our method is an association rule where each gene represents the minimum and maximum values of intervals of each attribute that belongs to such rule.

The filed weight (w_i) is a real-valued variable taking values in the range $[0..1]$. This variable indicates whether or not the potential attribute is present in the corresponding rule. More precisely, when w_i is smaller than a user-defined threshold (called *Limit*) the attribute will not be appeared in the related rule. Therefore, the greater the value of the threshold *Limit*, the smaller is the probability that the corresponding attribute will be included in related rule.

l_i and u_i are the limits of the intervals corresponding to the attribute A_i . The field r_i is also real valued variable in the range $[0..1]$. This part in each individual is used to determine whether the candidate rule is included in set or not.

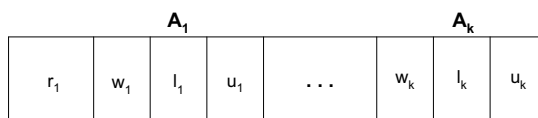

Figure 2. Representation of an individual

Note that the above encoding is quite flexible with respect to the length and number of the rules. A traditional GA is very limited in this aspect, since it can only cope with fixed-length rule. In our approach, although each individual has a fixed length, the genes are interpreted (based on the value of the weight w_i) in such a way that the individual phenotype (the rule) has a variable length. The start of the first population consists of generating, arbitrarily, a fixed number of individuals during the evolution.

2.2. Objectives and Selection

The fitness of a set of rules in our method is assessed on the basis of *similarity*, *average support* and *average confidence*.

Average Support: The aim of this objective is to find the value of average support of the rules in candidate set. The support value of a rule indicates the number of records that belong to the rule that represent to the individual. If the number of rules in the set is low and their average support value is high, this means that these rules strong rules and they cover most of database. However, in some database like medical data, some instances are rarely occurred. In this case, if the user give a suitable minimum support for the database to be mined, these rare but potentially important instances are eliminated. In order to overcome such a problem and to remove the necessity for the user to pre-specify minimum support value, we employed average support objective for designing an autonomous rule mining.

Accuracy: The power of the association rule is directly related to the confidence value. Larger confidence value means that association between items in rule is strong. However, sometimes the rules with small confidence value may be interested to the user. Average confidence value consider the average of the all the rules in the set of rule instead of only one rule. So, the rules with small confidence value is sometimes included into the desired rule set.

Comprehensibility: This objective value of a set of association rules depends on the total number of items in the rules and the similarity between items present in the rules. For a good set of rules, it is expected that the total number of items in rules should be low and these items should be different from each other. So, the redundant items are removed from the rules. This means that if a set of rules has items in a little number, it is assumed that the complexity of that rule set becomes lower.

The following example demonstrates the comprehensibility of 4 rules found in a set with 5 items. The comprehensibility of a set of rules is computed as follows:

$$\text{Comprehensibility} = \frac{n - \sum_{i=1}^n d(i)}{n}$$

where, $d(i)$ is the percentage of appearance of i -th attribute in the set of rule and n is the total attribute number in the database. As an example, the percentage of appearance of the attribute A_1 for the set of rule in Table 1, $d(A_1)$, is 0.5. In the worst case, the comprehensibility becomes zero. The closer the value of this objective to one, the more comprehensibility is that set.

Table 1. An example set with 4 rules

	A₁	A₂	A₃	A₄	A₅
1	1	0	1	0	1
2	0	1	0	0	1
3	0	0	1	1	0
4	1	0	1	1	1

2.3. Genetic Operators

For the developed method, the usual one-point crossover operator is stochastically applied with a predefined probability, using two individuals of the selected pool. The crossover point is a percentage of the length of the individual that defines the starting point from where the crossover breaks the string. We use arithmetic crossover method in the experiments [8]. The employed method works as follows:

Consider two chromosomes $C_1 = (c_1^1, \dots, c_n^1)$ and $C_2 = (c_1^2, \dots, c_n^2)$. Applying the crossover operator on C_1 and C_2 generates two offspring $H_1 = (h_1^1, \dots, h_i^1, \dots, h_n^1)$ and $H_2 = (h_1^2, \dots, h_i^2, \dots, h_n^2)$, where for $i=1$ to n , $h_i^1 = \lambda c_i^1 + (1 - \lambda)c_i^2$ and $h_i^2 = \lambda c_i^2 + (1 - \lambda)c_i^1$.

In our experiments, λ varies with respect to the produced number of generations, as non-uniform arithmetical crossover.

The mutation operator is used to foster more exploration of the search space and to avoid unrecoverable loss of genetic material that leads to premature convergence to some local minima. In general, mutation is implemented by changing the value of a specific position of an individual with a given probability, denominated mutation probability. We developed three mutation operators tailored for our genome representation:

Shift the starting location towards the right: The value in the starting location of a randomly selected gene is increased by one.

Shift the starting location towards the left: The value in the starting location of a randomly selected gene is decreased by one.

Random-changing: The mutation produces a small integer number that is then added to or subtracted from the current content of any of length, weight or starting location. This is implemented in such a way that the lower and upper bounds the domain of the field are never exceeded.

To sum up, the process employed in this study can be summarized by the following algorithm,

The Algorithm:

Input: Population size N ; Maximum number of generations G ; Crossover probability p_c ; Mutation rate p_m .

Output: Nondominated set

```

P:=Initialize (P)
while the termination criterion is not satisfied do
C:=Select From (P)
Cl:=Genetic Operators (C)
P:=Replace (PUCl)
end while
return (P)

```

First, an initial population P is generated in Step 1. Pairs of parent solutions are chosen from the current population P in Step 3. The set of the selected pairs of parent solutions is denoted by C in Step 3. Crossover and mutation operations are applied to each pair in C to generate the offspring population C^l in Step 4. The next population is constructed by choosing good solutions from the merged population PUC^l . The pareto-dominance relation and a crowding measure are used to evaluate each solution in the current population P in Step 3 and the merged population PUC^l in Step 5. Elitism is implemented in Step 5 by choosing good solutions as members in the next population from the merged solution PUC^l .

3. Experimental Results

In this section, we present some experiments that have been carried out to test the efficiency and effectiveness of the proposed approach. All of the experiments were conducted on a Pentium C2D, 1.83GHz CPU with 1 GB of memory and running Windows Vista. As experimental data, we used two data sets with many numerical attributes: Socio-demographics and Biochemistry Datasets of Schizophrenia Patients from Firat University Hospital. We iterated the whole 10-CV procedure [9] ten times using different data partitions into ten subsets. Further, in all the experiments conducted in this study, the process started with a population of 200 individuals. As the termination criteria, the maximum number of generations has been fixed at 3000. Finally, while crossover probability is chosen to be 0.8 and the mutation rate of 0.3 was used for each kind of mutation.

The first experiment has been conducted to demonstrate the relationship between the average support and comprehensibility. As shown in Figure 3, as the comprehensibility of the set of rule found increases, average support values raises too. This is an expected result because the comprehensibility is partially propositional to the number of rules in the set of rule. As mentioned in Section 2.B, if the rules in a set consist of possibly different items, the larger number of rules normally increases the comprehensibility. However, this larger number is restricted with average support value. This is because as the number of the rules in the set increases, the average support value of the set decreases. These objectives are conflicting as suitable to the nature of multi-objective genetic algorithms.

The next experiment demonstrates the average confidence values of the sets of rule found on the previous experiments. In this experiment, the comprehensibility value is

same with the previous one. It should be noted that the values of the average confidence in this second experiment are independent from the comprehensibility value.

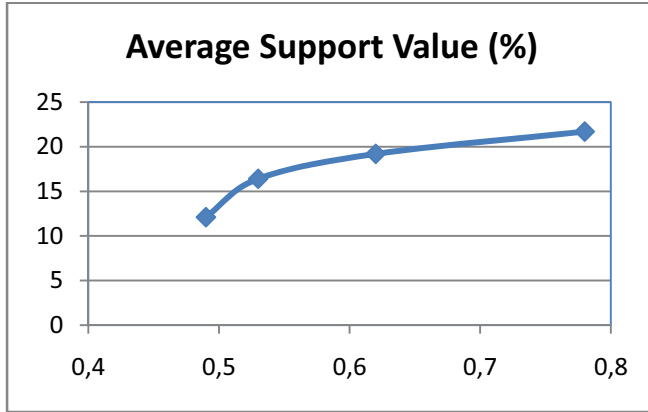

Figure 3. Average support and comprehensibility values of four sets of rule

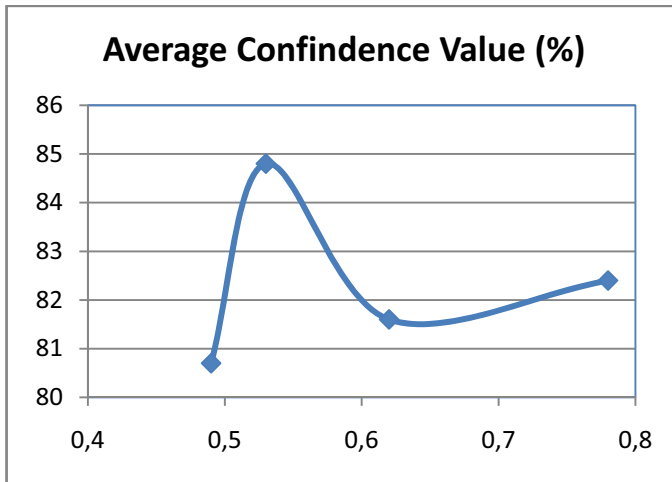

Figure 4. Average confidence and comprehensibility values of four sets of rule

4. Discussion and Conclusions

In this paper, we have explored the use of multi-objective genetic algorithms for designing autonomous rule mining. We also contributed to the ongoing research by proposing the multi-objective GA based method for mining efficient association rules with respect to the new defined criteria. These criteria are comprehensibility, average confidence value and average support value. To evaluate our method, we have conducted some experiments. The results have shown that our algorithm is effective, efficiency and promising.

The experiments conducted on real data sets illustrated that multi-objective GA is more appropriate and can be used more effectively to achieve nondominated solutions than the classical algorithms described in the literature. The results of two data sets are consistent and hence encouraging. In the future, we are planning to investigate the possibility of applying different objectives to association rule mining problem and to develop and improve different corresponding algorithms for this purpose.

References

- [1] Agrawal A., and Srikant R., "Fast algorithms for mining association rules in large databases". In Jorge B. Bocca, Matthias Jarke, and Carlo Zaniolo, editors, Proceedings of the 20th International Conference on Very Large Data Bases, VLDB, pages 487-499, Santiago, Chile, September 1994.
- [2] Jiawei Han, Jian Pei, Yiwen Yin, and Runying Mao. "Mining frequent patterns without candidate generation". *Data Mining and Knowledge Discovery* 8:53-87, 2004.
- [3] R. Srikant and R. Agrawal, "Mining quantitative association rules in large relational tables," *Proceedings of ACM SIGMOD*, Montreal, Canada, pp.1-12, 1996.
- [4] Tan K.C., Yu Q., Heng C.M. and Lee T.H., "Evolutionary computing for knowledge discovery in medical diagnosis", *Artificial Intelligence in Medicine*, Vol. 27, 129-154, 2003.
- [5] Zitzler, E. and Thiele, L., "Multiobjective Evolutionary Algorithms: A Comparative Case Study and the Strength Pareto Approach," *IEEE Transaction on Evolutionary Computation*, Vol.3, No.4, pp.257-271, 1999.
- [6] Holland, J.H., 1975. *Adaptation in Natural and Artificial Systems*. Ann Arbor, MI: Univ. Mich. Press.
- [7] Deb, K. et al., "A fast and elitist multi-objective genetic algorithm: NSGA II", *IEEE Trans. Evolutionary Computation*, 6, 182-197, 2002.
- [8] Herrera, F. et al., 1998. Tackling real-coded genetic algorithms: operators and tools for behavioural analysis. *Artificial Intelligence Review*, 12, 265-319.
- [9] Elomaa T., and Rousu J., "General and Efficient Multisplitting of Numerical Attributes", *Machine Learning*, 36: 201-244, 1999.
- [10] Narukawa K., Nojima Y. and Ishibuchi H., "Modification of Evolutionary Multiobjective Optimization Algorithms for Multiobjective Design of Fuzzy Rule-Based Classification Systems", *IEEE International Conference on Fuzzy Systems*, 809-814, 2005.
- [11] Dehuri S., Patnaik S., Ghosh A. and Mall R., "Application of elitist multi-objective genetic algorithm for classification rule generation", *Applied Soft Computing*, 8(1): 477-487, January 2008.
- [12] Yan X., Zhang C. and Zhang S., "Genetic algorithm-based strategy for identifying association rules without specifying actual minimum support", *Expert Systems with Applications*, 36(2) part:2, pp.3066-3076, March 2009.
- [13] Kaya, M., Alhajj, R., Polat, F. and Arslan, A., "Efficient Automated Mining of Fuzzy Association Rules," *Proceedings of the International Conference on Database and Expert Systems with Applications*, 2002.
- [14] B. Minaei-Bidgoli, R. Barmaki, M. Nasiri., "Mining numerical association rules via multi-objective genetic algorithms", *Information Sciences*, Volume 233, 1 June 2013, Pages 15-24
- [15] Kaya M., "Autonomous classifiers with understandable rule using multi-objective genetic algorithms, *Expert Systems with Applications*, Volume 37, Issue 4, pp.3489-3494, April 2010.
- [16] Silberschatz, A. and Tuzhulin, A., "What makes patterns interesting in knowledge discovery systems", *IEEE Transactions on Knowledge and Data Engineering*, 8:6, pp.970-974, 1996.

Steps Toward End-to-End Personalized AAL Services

Amedeo Cesta ^{a,1}, Luca Coraci ^a, Gabriella Cortellessa ^a, Riccardo De Benedictis ^a,
Andrea Orlandini ^a, Filippo Palumbo ^b and Ales Stimec ^c

^a *CNR – National Research Council of Italy, ISTC, Rome, Italy*

^b *CNR – National Research Council of Italy, ISTI, Pisa, Italy*

^c *XLAB, Ljubljana, Slovenia*

Abstract. In Ambient Assisted Living research and development, a significant effort has been dedicated to issues like gathering continuous information at home, standardizing formats in order to create environments more easily, extracting further information from raw data using different techniques to reconstruct context. An aspect relatively less developed but also important is the design of personalized end-to-end services for technology users being them either primary (older people) or secondary (medical doctors, caregiver, relatives). This paper explores an effort, internal to the EU project GIRAFFPLUS, for designing such services starting from a state-of-the-art continuous data gathering infrastructure. The paper presents the general project idea, the current choices for the middleware infrastructure and the pursued direction for a set of services personalized to different classes of users.

Keywords. Ambient Assisted Living, Personalized Interactive Services, Long-term Data Monitoring, Older People Support.

Introduction

In recent years there is an increasing attention of the topic of “prolonging independent living”. Several initiatives all over the world have focused attention on the problem of the aging population (see [16] and many others) and funding programs have been triggered like the Ambient Assisted Living (AAL), promoted by the European Commission in the FP7 research areas, more specifically, in the “AAL Joint Program”. The general aim is the one of promoting a healthier society constituting a main social and economic challenge. In fact, most elderly people aim at remaining in their homes as long as possible as this is in general conducive of a richer social life and paramount to maintaining established habits. To adhere to this wish is also positive from an economic perspective as the cost of care at home is almost always much less than the cost of residential care.

Several issues need to be addressed in order to prolong independent living. One is early detection of possible deterioration of health so that problems can be remediated in an early stage and timely involvement of health care providers and family can be assured. A second issue is to provide adaptive support which can offer services to assist in coping with age-related impairments. Third, ways of supporting preventive medicine must be

¹Corresponding Author: Amedeo Cesta, ISTC-CNR, Via San Martino della Battaglia 44, Roma (Italy); E-mail: amedeo.cesta@istc.cnr.it.

found as it has been increasingly recognized that preventive medicine can contribute to promoting a healthy lifestyle and delay the onset of age-related illnesses. Observing the current efforts in the AAL projects, and the trends in the “internet of things” [12,3], an amount of R&D effort exists on issues like the gathering of continuous information at home, the standardization of formats in order to create environments more easily, the extraction of further information from raw data using different techniques to reconstruct context, etc. This paper aims to underscore one further aspect for research in the area: the need for personalizing services starting from the data and arriving to serve real needs of users. In particular elaborating on current work in an EU project called GIRAFFPLUS we will underscore the relevance of producing a comprehensive approach toward end-users.

Plan of the Paper. The paper first discusses additional motivations and related work in Section 1 then introduces the GIRAFFPLUS project broad idea in Section 2. Section 3 describes the system architecture and the basic data support services, while Section 4 presents the interactive and personalization services, trying to demonstrate how such services create a needed glue for adapting the technology to the users. A concluding section ends the paper.

1. Motivations and Context

Evolving access to information and to computing resources into an utility is a big target in the current ICT research fields. As stated in [4], the computing facilities of large enterprises are evolving into an utility. This is true for AAL systems especially when integrated with Healthcare Information Systems (HIS), which should become far more portable from one site to another in order to limit development and maintenance costs. Reusing legacy software, developing mediation systems, component-based architectures, or implementing client adaptation through proxies are common situations in this context. This kind of applications use intermediate software that resides on top of the operating systems and communication protocols to perform the following functions: hiding distribution (i.e. the fact that an application is usually made up of many interconnected parts running in distributed locations), hiding heterogeneity (i.e. various hardware components, operating systems and communication protocols that are used by the different parts of an application), providing uniform and standard high-level interfaces (so that applications can easily interoperate and be reused, ported, and composed), supplying a set of common services to perform various general purpose functions, in order to avoid duplicating efforts and to facilitate collaboration between applications. This intermediate software layer have come to be known under the generic name of middleware. Using middleware has many benefits, most of which derive from abstraction: hiding low-level details, providing language and platform independence, reusing expertise and possibly code, easing application evolution. As a consequence, the application development cost is reduced, while quality (since most efforts may be devoted to application specific problems), portability and interoperability are increased [10].

The current effort in the GIRAFFPLUS project is in designing and implementing personalized services for end users on top of a state-of-the-art continuous data-gathering infrastructure. The GIRAFFPLUS project aims to develop and evaluate a complete system able to collect elderlys daily behavior and physiological measures from distributed sensors in living environments as well as to organize the gathered information so as to provide customizable visualization and monitoring services for both primary and secondary users. In this regard, a Data Visualization, Personalization and Interaction Service (DVPIS) has been realized to manage interaction with the different actors in such

AAL scenario. In particular, two different instances of the DVPIS have been provided: one for use “outside the home” (DVPIS@Office), and another dedicated to the primary user (DVPIS@Home). The benefit pursued by the GIRAFFPLUS system is twofold: primary users can access the information on their own health condition, enabling them to better manage their health and lifestyle; secondary users are supported by a flexible and efficient monitoring tool while taking care of old persons (relatives/patients).

Related Projects. As said before, the European Commission is promoting many different research initiatives on Ambient Intelligence, particularly focusing on multi-sensorial environments and distributed ICT services. Among others, the UNIVERSAAL [18] project can be considered the major representative of such effort. In fact, it is an FP7 project aiming to standardize an open platform and reference specification for AAL. In particular, UNIVERSAAL is working to the consolidation of other relevant projects results like SOPRANO [17], MPOWER [13], PERSONA [19], OASIS [15], VAALID [2], AALIANCE [1]. Furthermore, projects have focused their efforts in generating more specific AAL technologies. For instance, the telepresence robot called Giraff is currently under evaluation in the ExCITE project [5] while high-level automated reasoning services for supporting end users have been proposed, e.g., in RoboCare [6] and PEIS [14], constituting a relevant example of research initiatives whose main objective is to infer semantic information from raw sensorial data collected in ambient intelligence environments. All the above research activities provide a technological context as a building block for the GIRAFFPLUS project.

2. The GIRAFFPLUS General Idea

The GIRAFFPLUS project’s (<http://www.giraffplus.eu/>) focal points are the following:

- to develop and thoroughly evaluate a complete system able to collect elderly people’s daily behavior and physiological measures from distributed sensors, to perform context recognition and long-term trend analysis;
- to organize the gathered information so as to provide customizable visualization and monitoring services for caregivers;
- to foster social interaction between primary users (elderly) and secondary users (formal and informal caregivers). In broad terms, secondary users can virtually enter the home for a visit or to respond to an event generated by the system, while primary users can request a virtual visit at any time.

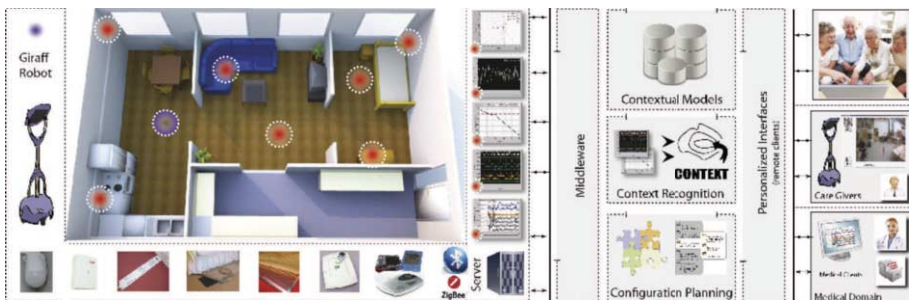

Figure 1. The GIRAFFPLUS complete idea.

The Figure 1 graphically illustrates the main components of the system (described in detail in [7]). The GIRAFFPLUS system includes a network of sensors (red dots in the figure) constituted by both physiological as well as environmental sensors that measure both the physical status of the primary user, e.g. the blood pressure, and detect the environmental condition of the home living environment, e.g. whether somebody occupies a chair, falls down or moves inside a room. The data from these sensors are interpreted by an intelligent system (called the Context Recognition), in terms of activities, health and wellbeing: e.g. the person is exercising or the person is going to bed, or a fall has occurred. Then, these activities can also trigger alarms or reminders to the primary user or his/her caregivers, or be analyzed off line and over time by a healthcare professional. The system should automatically adapt to perform specific services such as checking the persons night activities. Personalized interfaces for primary and secondary users are developed to access and analyze the information from the context recognition system for different purposes and over different time scales. An important feature of the system is an infrastructure (the Configuration Planning) for adding and removing new sensors seamlessly and to automatically configure the system for different services given the available sensors. The above features provide an adaptive support which facilitates timely involvement of caregivers and allows monitoring relevant parameters only when needed. There is also a telepresence robot, called Giraff, which can be moved around in the home by somebody connected to it over Internet, e.g. a caregiver. The Giraff robot is a mobile communication platform, equipped with video camera, display, microphone and speakers, and a touch screen. It helps the user to maintain his/her social contacts.

Secondary users of the systems are family, friends, informal and formal care givers and health professionals. They access the system via a PC. We envision two main kinds of secondary users of the system: relatives/friends that connect with the Giraff robot and medical personnel that examine trends of collected data. The first kind of users, besides the ability to communicate with the Giraff robot, can also see significant information about what has happened in the home, for instance activities that the elderly has done and physiological parameters that have been measured. Medical personnel see the information collected off-line and can analyze trends in the data, for instance a decline of physical activities during a longer period of time.

One of the peculiar objective of the project is the design and development of a system capable of allowing the personalization of the secondary users interface as well as the selection of what information is supposed to be monitored in agreement with the primary users. Another additional important feature of the system that we are investigating is to empower the elderly enabling the access to the information elaborated by the system through an interface present in the home. Then, the elderly can have also the possibility to see in that interface which secondary users may access the different kind of information. Finally, the system can also rise alarms and send warnings, for instance, in case of falls or in case of abnormal physiological parameters.

In the project, particular emphasis is also put on user evaluation outside the laboratories. In fact, the GIRAFFPLUS system will be installed and evaluated in 15 homes of elderly people distributed in three European countries, i.e., Italy, Spain and Sweden. In particular, the concept of "useworthiness" is central in order to assure that the GIRAFFPLUS system provides services that are easy and worth using. Then, these evaluations will drive further the development of the system.

3. The GIRAFFPLUS Architecture

This section describes the general architecture of the GIRAFFPLUS system. In particular, we present the specification of the system in terms of components, functionalities and interfaces among components. Also, here it is described how the components are integrated and interfaced with the rest of the system. Figure 2 depicts an abstract component diagram of the GIRAFFPLUS system. In particular, three main components can be identified: (a) the Physical Environment and Software Infrastructure, (b) the Middleware Infrastructure and (c) the Service Layer.

The *Physical Environment and Software Infrastructure* coupled with the *Middleware Infrastructure* (see Fig. 2) represent the basic level of functionalities of the GIRAFFPLUS system. Indeed, all the data services are grounded on the functionalities of this part of the system and these modules that are also in charge of providing the common and interoperable communication service. In particular, the *Middleware Infrastructure*

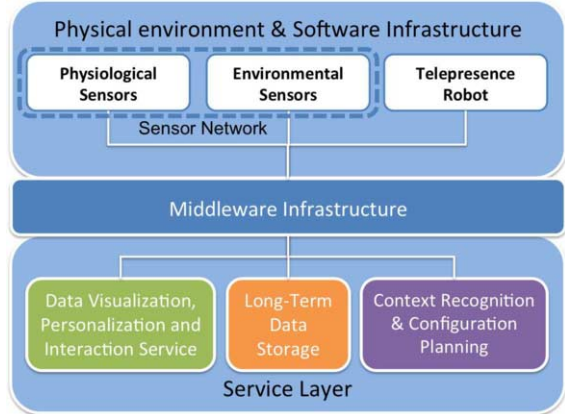

Figure 2.: The GIRAFFPLUS components.

constitutes a gateway shared among all the system components. Then, the *Sensor Network*, composed by both *Physiological and Environmental sensors*, gathers the information generated in the home environment as well as provides the (possibly pre-processed) collected data. Finally, the *Telepresence Robot* provides the GIRAFFPLUS social interaction functionalities enabling remote access in the environment through a Pilot software embedded in the visualization and interaction services (see Sec. 4). The *Long-Term Data Storage* component (see again Fig. 2) is responsible for providing a general database service for all the data generated by parts of the system and providing data access functionalities. Specifically, the main role of this component is to manage a database containing all the data collected through the *Middleware Infrastructure* and generated by the *Sensors Network* (see section 3.2). The *Context Recognition and Configuration Planning* (bottom-right in Fig. 2) is the component responsible for context/activity recognition and system configuration planning, i.e., two high-level reasoning systems in charge of (respectively) implementing the monitoring activities by means of context/activity recognition [20] and providing suitable configuration settings for the *Sensors Network* according to the requested monitoring activities [11]². Finally, the *Data Visualization, Personalization and Interaction Service* (bottom-left in Fig. 2) is the part of the system responsible for creating user-oriented service. A broad way to summarize the module is to provide different end-users with suitable interaction modalities for the available services. In Section 4, a more thorough presentation of this module is provided.

²The description of the Context Recognition and Configuration Planning components is out of the scope of the present paper. The reader may refer to [7] for further details.

3.1. AAL Middleware for GIRAFFPLUS

In the GIRAFFPLUS system, a crucial role is played by the Middleware Infrastructure as it provides the central connection point that is shared by all the components according to the needed information exchanges. In fact, given the inner context-aware nature of GIRAFFPLUS system, the presence of a pervasive solution that provides any kind of information about the interaction between the user and the surrounding environment become a key aspect for its effectiveness. The sensors, the services, and the components integrated in the GIRAFFPLUS system need a software infrastructure, which is based on a middleware that hides heterogeneity and distribution of the computational resources in the environment. Moreover, the integration of such components is demanding, especially if we consider that the system is composed of different services written in different languages and it may need to be accessible by a number of remote healthcare centers which may use different protocols. To this aim, an AAL middleware solution well suited to the GIRAFFPLUS context is proposed.

The fragmentation in this sector is still high, but there are initiatives working to build converging solutions. Service interoperability is a key point to build an ecosystem of applications that helps the growth of an AAL consumer market. In this regards, several European projects have intensely worked to the definition and standardization of a common platform for AAL, on top of which to develop intelligent software applications for the end users (see the *Related Projects* section). In this regard, the final objective of the GIRAFFPLUS project is to design and develop a system compliant to the results of the most promising research projects in this field, i.e., universAAL [18].

It was the intention of this work to be aligned to the universAAL results, to reuse the Open Source software released by universAAL as much as possible, and to share the use cases based on the teleoperated robot system in order to enrich the universAAL platform with the technological requirements deriving from the GIRAFFPLUS project. The concrete architecture currently selected by universAAL is based on the Java/OSGi platform and it is aligned with the reference platform selected by GIRAFFPLUS.

Middleware Architecture. Within the proposed AAL ecosystem, hardware as well as software components can be able to share their capabilities. In the GIRAFFPLUS space, the proposed platform facilitates the sharing of two types of capabilities: Service (description, discovery and control of components) and Context (data based on shared models). Therefore, connecting components to the platform is equivalent to using the brokerage mechanism of the middleware in these two areas for interacting with other components in the system. The concrete middleware architecture is made up of two layers: a core middleware API layer and a communication layer that includes a publish/subscribe connector and a RESTful connector (Figure 3).

A generic service built upon the middleware can discover which sensors are present in the environment and other services together with their functionalities using methods from the middleware API layer. The underlying layer fulfills these requests exploiting

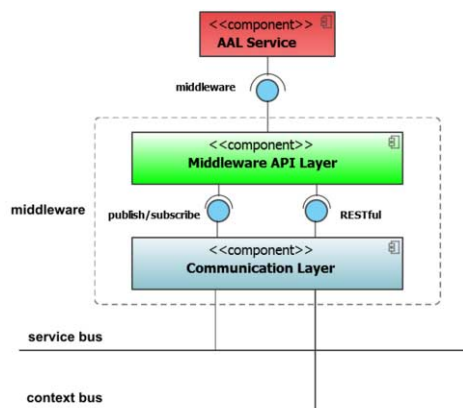

Figure 3. The proposed middleware architecture

the connectors available. In the communication layer, an MQTT [9] and a RESTful [8] connector are present. By mean of these connectors, the middleware realizes a publish/subscribe as well as a methods description/invoke mechanism in a transparent way.

Two buses form the heart of the proposed middleware: a context bus and a service bus. All communications between applications (i.e., the GIRAFFPLUS services) can happen in a round-about way via one of them, even if physically, the applications are located on the same hardware node. Each of the buses handles a specific type of message/request and is realized by different kinds of topics. The aim of the middleware is to provide a publish/subscribe mechanism for accessing the context information about the physical environment and physiological data. This information will be exposed as different topics: topics for discovery and description of devices and services that form the service bus and topics for publishing and retrieving data from devices and services that form the context bus. The middleware is in charge of presenting the available sensors and services in the system implementing an announce mechanism on the service bus. These resources are presented with a message on the relative topic in the service bus. The message is a descriptor file containing an id, a description, a type (i.e exporter or service), a set of resources (i.e. sensors or components), and a set of methods. Once a resource has been announced on the service bus a generic service can search for it filtering on the descriptor fields and use it. The topics used for announce and discovery of devices and service, the so called service bus, has this format

```
<<location>>\serviceBus\<<serviceID>>
```

where `location` identifies, e.g., the room in the assisted persons apartment, `serviceBus` is the keyword to identify the topic as a service bus topic and `serviceID` is the unique identifier of the service. The message of this topic is a JSON descriptor file. The middleware takes care of dispatching information about the state of the resources among services by means of a context bus. Any service that wants to make available his data (sensors readings and events or data analysis results) can use the middleware API to publish it. Any service interested of monitoring these data can subscribe to the relative context bus topics indicated in the descriptor using the middleware API. The topics used for gathering data from devices and service, the so called context bus, has this format:

```
<<location>>\contextBus\<<serviceID>>\<<subtreefield>>
```

where `location` identifies the room, `contextBus` is the keyword to identify the topic as a context bus topic, `serviceID` is the unique identifier of the service and the `subtreefield` identifies all the resources of that service that can be monitored. For each resources there will be a dedicated context bus sub-topic. The message of these topics is a string value.

3.2. Long-Term Data Storage service

The Long-Term Data Storage module aims to provide a central storage for the GIRAFFPLUS system, responsible for storing all the data collected by the Physical Environment, as well as the data produced by other components (High-Level Services). Additionally, it also stores configuration data (sensor data, security restrictions, etc.) and logging data from all the software components in the system (all logs are centrally available, and therefore it is easier to maintain and debug the system). Such service consists of three

connected components: (i) the database, which stores the actual data; (ii) the GIRAFFPLUS Middleware Listener component, which is instantiated in the middleware and forwards all relevant data to the database in a secure fashion; (iii) the RESTful web service, which enables secure access to the database and (iv) the GIRAFFPLUS Middleware Storage component, which enables other GIRAFFPLUS components to directly access the data via the middleware.

The guiding principles in the design of the GIRAFFPLUS Long-Term Data Storage system have been **security, flexibility, reliability, efficiency** and **scalability**. Security is paramount as we are dealing with potentially sensitive information. Flexibility is important as GIRAFFPLUS is a research project and then it is impossible to foresee all the possible data structures that might be stored in the system, as well as all possible connections between them. The storage system needs to be able to reliably store vast amounts of data and enable users and other GIRAFFPLUS components to efficiently access the stored data. Last but not least, the system needs to be scalable as we expect the amount of data to vastly increase during the course of the project and hopefully, during the commercialization phase of the project.

The GIRAFFPLUS database. After a careful examination of available database solutions, we decided to use MongoDB (<http://www.mongodb.org/>), which is a widely used, open source, NoSQL document-oriented database system developed and supported by 10gen (<http://www.10gen.com/>). To follow our guiding principles, we make heavy use of its replication feature, which replicates data over specified groups of servers thereby increasing data reliability, as well as efficiency. We also use the sharding feature, which distributes the data over many replica groups, thereby enabling horizontal scalability and increasing efficiency via load-balancing. Flexibility of the system is achieved due to its NoSQL nature, since the database stores collections of generic JSON (<http://www.json.org/>) objects, which can represent various data-structures that might come up during the lifetime of the project. To increase efficiency we also implemented a database compression method, which compresses collections of data older than a specified date. The method automatically collects data objects coming from the same source and compresses the array of dynamic field values. To retrieve data from compressed collections of object, the method first uncompresses the data and then runs the required filter over them.

The GiraffPlus Middleware Listener component. The GIRAFFPLUS Middleware Listener component is instantiated automatically as the middleware is run. It listens to all data sources connected to the middleware (sensors, other components, logs, *etc.*), properly formats the data, attaches the timestamp and stores the data in the database.

The RESTful GiraffPlus Storage Web Service. The implemented RESTful (REpresentational State Transfer) web service enables secure (using certificates via SSL) and efficient access to the data stored in the database. It is implemented in Java using Jersey (<https://jersey.java.net/>), which is an open-source, production quality, JAX-RS Reference Implementation for building web services. To run the web service we use the Apache Tomcat (<http://tomcat.apache.org/>), which is an open source software implementation of the Java Servlet and JavaServer Pages technologies and enables easy scalability by using load-balancing between multiple servers.

Data between the web service and its clients is exchanged in JSON format and, if required by the client, compressed to increase the efficiency of data transfer.

The GiraffPlus Middleware Storage component. We predict that at some point during the project there might be multiple Long-term Data Storage centers (LTDC) located in

various locations around Europe (and later on outside Europe) due to possible legal or performance constraints. One of the design goals for the Long-term Data Storage system was to enable partners to write data-location agnostic applications and components. Therefore the only point of contact for each application/component should be the GIRAFFPLUS Middleware and requests for data storage or retrieval should be done via the middleware. For this purpose we implemented a simple Storage component. Its configuration contains the location of the LTDSC to be used for the instantiated middleware and all requests for data storage and retrieval are done through the Storage component, which then forwards requests to the corresponding LTDSC. In this fashion we enable developers to write data-location agnostic applications and components, or, if required, to forward data requests to a specific LTDSC, which contains the requested data.

4. DVPIS: the Data Visualization, Personalization and Interaction Service

The GIRAFFPLUS infrastructure described in the previous section guarantees two very important aspects: (a) the long term storage of sensor data; (b) the possibility of real time connection for information sharing and immediate alarm intervention.³ The work on user-oriented services has started with an analysis of the different type of people that can take advantage of the GIRAFFPLUS services. The basic subdivision between users concerns Primary (the old person in the house) vs. Secondary (different people outside the house). The secondary users can be subdivided in various groups: within GIRAFFPLUS we are particularly interested in services for (1) formal caregivers (e.g., doctors, social workers); (2) informal caregivers (e.g., relatives). A further basic question now is “how can we build useful services for such users?”. One interesting distinction concerns the service time constant we are expecting: (a) long term data analysis, for example, to observe trends for creating regular reports for different users, (b) short term reactive services, like in the case of alarms, to detect emergencies (e.g., fall detection sensors, emergency call buttons, etc.) (c) continuous asynchronous dialogues (e.g., in the case of social network channels, reminding services, etc.) (d) synchronous communication channels for conversations through the telepresence robots.

Figure 4 describes the complete scenario we have realized. Again we underscore different aspects: first of all the double directionality pursued in the complete GIRAFFPLUS service model: (a) Internal vs. External Data Flow: there is a basic direction of data gathering from the house toward the external world (red arrows in the figure). Notice that we distinguish: (1) long term data storage for subsequent analysis and on-demand visualization (red arrow in upper part of the figure), and (2) direct real-time fast connections managed directly through the middleware for alarms (red arrow in lower part); (b) Bidirectional External/Internal communication: this channel allow to support the social interaction services. Initially, the basic telepresence services of the Giraff telepresence robot have been created (www.giraff.com), subsequently the system has been empowered with additional services for increasing support to the primary users (blue arrow in the figure).

The Figure 4 also identify the modules specifically called DVPIS (for Data Visualization, Personalization and Interaction Service) that have been realized to manage interaction with the different actors in an AAL scenario. In particular we have two instances of the DVPIS one for use “outside the house” called DVPIS@Office and another dedi-

³As said before we do not use here the features of the Context Recognition and Configuration Planning module that also aims at creating added value services on top of the basic infrastructure (e.g., enriching the basic gathered data with additional temporal deductions).

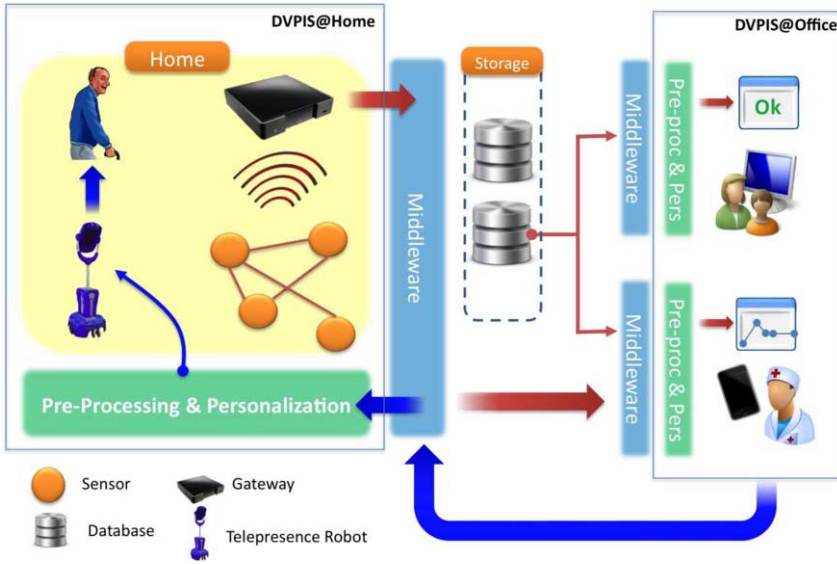

Figure 4. Outside vs. Inside services through DVPIS.

cated to the primary user called DVPIS@Home. Both the DVPIS modules are composed of a front-end which is a visualizer and interaction manager and a back-end that deals with pre-processing of data and personalization of services.

DVPIS@Office. The module dedicated to secondary users strongly rely on querying the data store. Additionally access to the telepresence robot via its external interface is possible within the same comprehensive layout. At present we have designed an interaction front-end that runs on a personal computer but the technological choices allow us to develop also App-style versions for other mobile platforms like tablets or smartphones. Different services are provided for formal and informal caregivers. The personalization for a doctor or a social worker takes into account the fact that this workers may connect to multiple patients at home. Hence there is an environment that manages different houses and help the user to maintain information on the different cases he/she follows. The formal caregiver may access data over time, although specialized the visualization environment allows a combination of queries that are able to generate different graphical views. Figure 5-B presents a test example of the current DVPIS@Office for a doctor observing a week of blood pressure data. Figure 5-A shows a user inspecting a printed report received through the GIRAFFPLUS system and at the same time has decided to query the long term data for observing temporal trends (see the PC screen). The personalization for an informal caregiver (the current target is a relative of the person at home) is far straightforward. Such a person needs a more synthetic information and just report about warning over an interval of time. At present it is possible to ask for daily reports that contain a summary of the informations of the day. We are currently working at producing a scenario similar to the one in Figure 5-A tailored for informal caregivers, with reports that contain a different perspective on the information delivered.

DVPIS@Home. The current front-end in the house for delivering information services is the telepresence robot. In fact, some user requirements gathered during the initial phase of the project suggested to avoid the introduction of further technological objects in the house. In addition, as the Giraff robot is integral part of the project comprehensive design



Figure 5. The current DVPIS in operation.

and has a computer on-board for its basic operations, we have decided to exploit it to run the local additional software services. Specifically for the project the company producing the robot has synthesized a touch screen version. The DVPIS@Home is designed to take advantage of this new functionality, somehow the telepresence robot resembles a “tablet on wheels” from the point of view of old people at home. The front end (a) allows to access the standard telepresence services of the robot (b) allows the home users to read simplified reports concerning his/her own health status (c) enable the delivery of asynchronous messages to the user. This last functionality is currently integrated for obtaining a reminding service (a message example is shown in Figure 5-D).

The DVPIS shared dialogue space. The GIRAFFPLUS project is in its second year. Since the first dialogue with potential home users the problem of the dialogue Inside/Outside has been a very important one. For this reason we are endowing the DVPIS of a capability of synchronous communication fully supported by the middleware. Using this functionality we have created a shared information space that allows a dialogue Primary/Secondary user sharing some information on the screen. The current demo of this functionality is shown in the combination of Figure 5-B and -C. It is possible to see that the same information (the weekly blood pressure samples) are in front of the doctor in her office and of the old person at home and they can share also the audio channel for talking. In this way we have set up an environment for flexible end-to-end information delivery on top of an AAL service.

5. Conclusions

This paper presents an ongoing effort to create added value complete services for end users on top of an AAL continuous data gathering environment. It describes the main architectural choices concerning the middleware (UNIVERSAAL compliant), the long-term data storage, and the more abstract component dedicated to interaction and personalization for different users of the AAL environment (the DVPIS module). It is worth underscoring how the interaction services provided by the DVPIS pave the way for creating a complete approach for differentiated users (what can be called an end-to-end service connection to users). The paper contains an initial report on the @Office and @Home services, while an evaluation with users is still on going. Such an evaluation aims at validating the design choices as well as to collect further feedback to be exploited for future iterative design refinements.

Acknowledgements. Authors are partially funded by the European Community’s Framework Programme Seven (FP7) under the GIRAFFPLUS project (contract #288173. FP7 - ICT - Challenge

5: ICT for Health, Ageing Well, Inclusion and Governance). Filippo Palumbo is also partially supported by FP7 under the UNIVERSAAL project (contract N.247950).

References

- [1] AALIANCE Innovation platform: <http://www.aaliance.eu/public>.
- [2] Accessibility and Usability Validation Framework for AAL Interaction Design Process: <http://www.vaalid-project.org/>.
- [3] AZTIRIA, A., AUGUSTO, J., BASAGOITI, R., IZAGUIRRE, A., AND COOK, D. Discovering Frequent User-Environment Interactions in Intelligent Environments. *Personal and Ubiquitous Computing* 16, 1 (2012), 91–103.
- [4] BERNSTEIN, P. A. Middleware: a model for distributed system services. *Commun. ACM* 39, 2 (Feb. 1996), 86–98.
- [5] CESTA, A., CORTELLESA, G., ORLANDINI, A., AND TIBERIO, L. Evaluating telepresence robots in the field. In *Agents and Artificial Intelligence*. Springer Berlin Heidelberg, 2013, pp. 433–448.
- [6] CESTA, A., CORTELLESA, G., RASCONI, R., PECORA, F., SCOPELLITI, M., AND TIBERIO, L. Monitoring elderly people with the robocare domestic environment: Interaction synthesis and user evaluation. *Computational Intelligence* 27, 1 (2011), 60–82.
- [7] CORADESCHI, S., CESTA, A., CORTELLESA, G., CORACI, L., GONZALEZ, J., KARLSSON, L., FURFARI, F., LOUTFI, A., ORLANDINI, A., PALUMBO, F., PECORA, F., VON RUMP, S., STIMEC, A., ULLBERG, J., AND OSTLUND, B. GiraffPlus: Combining Social Interaction and Long Term Monitoring for Promoting Independent Living. In *HSI: 6th International Conference on Human System Interaction* (2013).
- [8] FIELDING, R. T., AND TAYLOR, R. N. Principled design of the modern web architecture. *ACM Trans. Internet Techn* 2, 2 (2002), 115–150.
- [9] HUNKELER, U., TRUONG, H. L., AND STANFORD-CLARK, A. MQTT-S - A publish/subscribe protocol for wireless sensor networks. In *COMSWARE* (2008), IEEE, pp. 791–798.
- [10] KRAKOWIAK, S. *Middleware Architecture with Patterns and Frameworks*, 2009.
- [11] LUNDH, R., KARLSSON, L., AND SAFFIOTTI, A. Autonomous functional configuration of a network robot system. *Robotics and Autonomous Systems* 56, 10 (2008), 819–830.
- [12] MCCULLAGH, P., AND AUGUSTO, J. The Internet of Things: The Potential to Facilitate Health and Wellness. *CEPIS Upgrade: the European Journal for the Informatics Professional* XII, 1 (2011), 59–68.
- [13] MIKALSEN, M., HANKE, S., FUXREITER, T., WALDERHAUG, S., AND WIENHOFEN, L. W. M. Interoperability services in the mpower ambient assisted living platform. In *MIE* (2009), pp. 366–370.
- [14] PECORA, F., CIRILLO, M., DELL’OSA, F., ULLBERG, J., AND SAFFIOTTI, A. A constraint-based approach for proactive, context-aware human support. *Journal of Ambient Intelligence and Smart Environments* 4, 4 (2012), 347–367.
- [15] PIOGGIA, G., RICCI, G., BONFIGLIO, S., BEKIARIS, E., SICILIANO, G., AND DE ROSSI, D. An ontology-driven multisensorial platform to enable unobtrusive human monitoring and independent living. In *Intelligent Systems Design and Applications, 2009. ISDA '09. Ninth International Conference on* (2009), pp. 620–623.
- [16] POLLACK, M. Intelligent Technology for an Aging Population: The Use of AI to Assist Elders with Cognitive Impairment. *AI Magazine* 26, 2 (2005), 9–24.
- [17] SIXSMITH, A., MEULLER, S., LULL, F., KLEIN, M., BIERHOFF, I., DELANEY, S., AND SAVAGE, R. Soprano — an ambient assisted living system for supporting older people at home. In *Proceedings of the 7th International Conference on Smart Homes and Health Telematics: Ambient Assistive Health and Wellness Management in the Heart of the City* (Berlin, Heidelberg, 2009), ICOST '09, Springer-Verlag, pp. 233–236.
- [18] TAZARI, M.-R., FURFARI, F., FIDES-VALERO, Á., HANKE, S., HÖFTBERGER, O., KEHAGIAS, D., MOSMONDOR, M., WICHERT, R., AND WOLF, P. The universAAL reference model for AAL. In *Handbook of Ambient Assisted Living - Technology for Healthcare, Rehabilitation and Well-being*, vol. 11 of *Ambient Intelligence and Smart Environments*. IOS Press, 2012, pp. 610–625.
- [19] TAZARI, M.-R., FURFARI, F., LÁZARO RAMOS, J.-P., AND FERRO, E. The PERSONA service platform for AAL spaces. In *Handbook of Ambient Intelligence and Smart Environments*. 2010, pp. 1171–1199.
- [20] ULLBERG, J., AND PECORA, F. Propagating temporal constraints on sets of intervals. In *ICAPS Workshop on Planning and Scheduling with Timelines (PSTL)* (2012).

Social sub-group identification using social graph and semantic analysis

Bjørn Magnus MATHISEN ^{a,1}, Anders KOFOD-PETERSEN ^a, John MCGOVERN ^b,
Thomas VILARINHO ^a and Babak A. FARSHCHIAN ^a

^a SINTEF ICT, S. P. Andersens vei 15 b, 7465 Trondheim, Norway

^b TSSG, ArcLabs Research & Innovation Building, WIT, West Campus, Carriganore, Co. Waterford, Ireland

Abstract.

Social networks proliferate daily life, many are part of big groups within social networks, many of these groups contain people unknown to you, but with whom you share interests. Some of these shared interest are based on context which has real-time properties (e.g. Who would like to go to a jazz concert during an AI conference). This paper presents a possible method for identifying such subgroups. We aim to do this by creating a social graph based on one or more “comparators”; Frequency (how often two members interact) and content (how often the two talk about the same thing). After the graph is created we apply standard graph segmentation (clique estimation) techniques to identify the subgroups. We propose a system which continuously polls social network for updates, to keep the social graph up-to-date and based on that suggest new subgroups. As a result the system will suggest new subgroups in a timely and near real-time manner. This paper will focus on the methods behind the creation of the weighted social graph and the subsequent pruning of the social graph.

Keywords. Social Networks, Social graph, graph analysis, semantic analysis, text mining.

Introduction

In recent years, social networks have become prevalent throughout society [1,2]. The increasing importance of social networks drives the increase of users and traffic. However, increasing the number of users and traffic can easily present itself as a problem to most users. The “noise”, that is irrelevant information, increases and it becomes harder to discriminate which users and traffic to tune in to, which groups to join and which users you want to interact with. Thus, developing tools that can help to identify subgroups that are more relevant to a user, or a group of user is becoming more important.

Recently, work has been done to uncover methods for identifying community structures from the textual social interaction within a existing structure, see e.g. [3,4]. Most of these works is centred around the analysis of the social graph, where vertices (people) are joined together by links or edges (communication) [5]; different clustering

¹Corresponding Author: Bjørn Magnus Mathisen, SINTEF ICT, S. P. Andersens vei 15 b, 7465 Trondheim, Norway; E-mail: bjornmagnus.mathisen@sintef.no.

techniques largely developed from different metrics of graphs [6,7,8,9,10], with some of them having slightly different perspectives [11,12].

The work presented here is part of the on going Societies EU project² and demonstrates how directed and broadcast messages in social networks can be harvested and parsed to build new social graphs. The main focus of this paper is the algorithm that constructs the social graphs. The rest of the paper is organised as follows: Section 1, give an overview of relevant related work; Section 2 puts the graph building algorithm into context by briefly describe the overall architecture; this is followed by a description of the algorithm developed. The paper ends with a summary and outlook on future work.

1. Background and Related Work

Investigating structures and communication patterns in different forms of social networks has in the last decade received a growing interest.

Social graph are typically constructed by assigning people to the vertices and their interaction to the edges. This social interaction can be many things, but traditionally strength of connections have been popular. The strength is typically measured by counting number of messages. One such example is, Tyler et al., who describe how communities of practice can be identified from email correspondence within organisations [13]. The communities are identified solely from the sender and receiver of the email correspondence. The process was a two step process for constructing a graph. The graph consisted of nodes that were the senders and receivers of emails and links emails that connected the persons. The graph was then used to identify sub-graphs, or communities of nodes with many links between them.

The idea of counting the frequency of communication can also be employed in more loose settings. As an example, Gómez et al., build a social network based on the implicit relationship between authors of comments by other users on Slashdot.org [14]. The graphs build here does not represent a classic social network, but rather dynamic loose networks based on shared interests.

Assuming that interests form social networks, it would not be unreasonable to assume that these social networks would also share a lingo. Bryden et al, does indeed demonstrate that communities based on frequency of messages is closely mirrored by communities based on frequency of words [15]; that is people share a vocabulary with the people they communicate with.

Communication sharing the same lingo and interests have also been used to build social graphs. Examples are Lui et al., [16] and Anwar and Abulaish [17]. The latter further extends the notion of communities and language. They apply text mining techniques to generate social graphs based on similar posts. The authors crawls internet forums and maps, similar to [14], a *reply-to* relationship. Yet, they extend this by also clustering messages based on their similarity. This results in a social graph where the edges are a sum of the *reply-to*, that is message frequency and similarity.

²Project number: ICT-257493

2. System

The social graph builder deals with building social graphs centred around relevant users and groups.

The system is based on analysing activities (a subset of activities as defined in [18]), which are modeled as data-types consisting of triplets on the form: $[sender, receiver, message]$. The set of activities harvested is parsed into subset grouped by the sender. Such a subset will contain all activities and textual output from that sender, both directed (e.g. IM message) and broadcast (e.g. a tweet). All unique permutations of possible pairs of these subsets are then fed into the comparators. These comparators calculate a weight for the link between the two nodes in the social graph, if the two nodes already have a connection the weight is added onto the existing weight. This algorithm is detailed in section 3.1.

Figure 1 depicts the general system architecture which is composed of comparators acting as components in an ensemble system which rates the strength of an edge in the social graph.

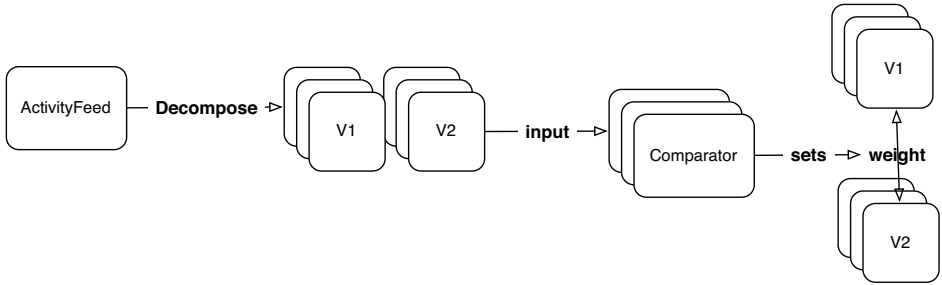

Figure 1. The system architecture

Figure 2 depicts the functional implementation of the architecture, as of now we are running three comparators:

1. **Frequency:** This comparator calculates a weight on the edge based on the frequency of communication between the two social graph vertices.
2. **Content:** This comparator calculates a weight on the edge based on the similarity content of the textual output of the two vertices connected via the edge.
3. **Directed content:** This comparator calculates the same similarity metric as the “Content” comparator, however it only analyses a subset of the communication, the communication being sent specifically between the vertices along the edge. (Thus the “Content” comparator would capture broadcasts e.g. tweets, and this comparator would not). However this weight is given greater significance.

3. Method

3.1. Algorithm

The general algorithm will be as follows, given as a input a list of activities where receiver can be n/a in the case of a broadcast. This can be as a stream or as a batch, as the algorithm will simply update it’s model for each new activity.

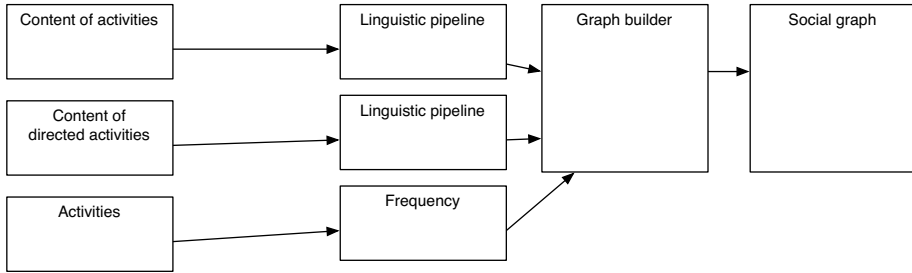

Figure 2. Functional System Architecture

The weight between two actors (vertices from now) is calculated in the following manner, the details of these two steps will be presented in subsections 3.3 and 3.2.

1. Calculate frequency of communication between any two vertices in the social graph.
2. Calculate the distance in content (keywords) between the textual output of every two vertices in the social graph. This step is actually carried out in two comparators (see section 2) of the functional system, on two different sets of input data, however the algorithm for comparison is equal.

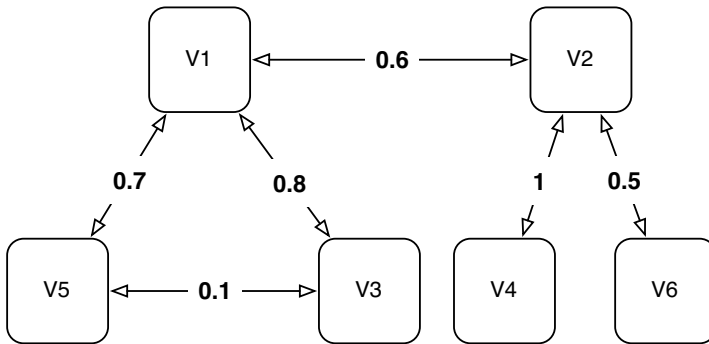

Figure 3. An example of a social network after weight calculation

After the network is pruned in the following manner to generate a sub-graph that captures subgroups:

1. Remove any edges with a weight below a certain threshold.
2. Apply the edge betweenness algorithm removing N edges.

3.2. Content classification

This is done using GATE[19,20] textual analysis pipeline, ANNIE. ANNIE is applied much in the same way as in [21]. Using ANNIE we extract keywords from the a given. Thus we can concat all text from different vertices, and produce a set of keywords for

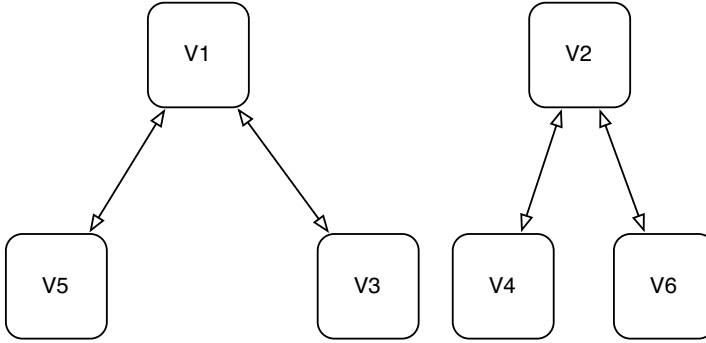

Figure 4. An example of a social network after pruning. In this pruning the first stage of the pruning (threshold) will remove the edge between vertices $V3$ and $V5$. The second stage of the pruning (betweenness) will remove the edge between vertices $V1$ and $V2$. After this pruning two subgroups are identified; $[V1, V3, V5]$ and $[V2, V4, V6]$

Algorithm 1 Generate network, and prune according to threshold. After running this algorithm the social graph is given by the weight matrix in fw . The original weight matrix w is also kept for next update of the social graph, when new activities are added to the stream.

```

1: for  $i = 0$  to  $getSize(Graph)$  do
2:   for  $j = 0$  to  $getSize(Graph)$  do
3:     if  $i \neq j$  then
4:       for  $k = 0$  to  $getSize(Comparators)$  do
5:          $w_{ij} = w_{ij} + runComparator(k, getVertex(i), getVertex(j))$ 
6:       end for
7:     end if
8:     if  $w_{ij} < threshold$  then
9:        $fw_{ij} = 0$ 
10:    else
11:       $fw_{ij} = w_{ij}$ 
12:    end if
13:  end for
14: end for

```

each vertex. This set of keywords can be compared against the set of the opposing vertex, producing a metric which is input for the weight of the edge between the vertices.

3.3. Graph analysis

After calculating the weighted graph and pruning the graph according to the threshold the edge-betweenness³ algorithm, also called the Girvan-Newman algorithm[6], is applied. We chose this algorithm over its faster counterparts e.g. [7] and to an even greater extent [8] because of its implementation simplicity⁴

³The term betweenness in the context of graphs was introduced by [22]

⁴The algorithm is readily available through the JUNG library: <http://jung.sourceforge.net/>

4. Summary and Future Work

This is a work in progress and the current system is limited by the run time of the ANNIE system, which requires a substantial CPU time for text analysis. This sets an upper threshold for the number of social network vertices and activities per vertex the system can handle before becoming unresponsive. In future versions we plan on implementing a subset of the ANNIE features, thus reducing the CPU time required for keyword extraction.

In addition we plan on adding a semi-supervised learning algorithm for tuning of the important parameters such as weight threshold.

Finally the architecture of the system, closely resembling an ensemble system, enables developers to add additional comparators. Thus we look forward to experimenting with new measurements of “likeness” within social interaction.

5. Acknowledgments

The work presented here is supported by the European R&D project SOCIETIES⁵.

6. Reproducibility

The work presented here is not bound by any dataset, the code that is based upon the concepts described in this paper is available as open-source (licensed under “FreeBSD” license) at this URL:

<https://github.com/societies/SOCIETIES-Platform>

References

- [1] D. J. Watts and S. H. Strogatz, “Collective dynamics of ‘small-world’ networks,” *nature*, vol. 393, no. 6684, pp. 440–442, 1998.
- [2] J. Scott, *Social network analysis*. SAGE Publications Limited, 2012.
- [3] J. Tyler, “Email as Spectroscopy: Automated Discovery of Community Structure within Organizations,” *Arxiv preprint cond-mat/0303264*, 2003.
- [4] M. Hönsch, “Detecting User Communities Based on Latent and Dynamic Interest on a News Portal,” *Personalized Web-Science, Technologies and Engineering*, vol. 3, no. 2, pp. 47–50, 2011.
- [5] S. H. Strogatz, “Exploring complex networks,” *Nature*, vol. 410, no. 6825, pp. 268–276, 2001.
- [6] M. Girvan and M. E. J. Newman, “Community structure in social and biological networks,” *Proceedings of the National Academy of Sciences of the United States of America*, vol. 99, no. 12, pp. 7821–6, Jun. 2002. [Online]. Available: <http://www.pubmedcentral.nih.gov/articlerender.fcgi?artid=122977&tool=pmcentrez&rendertype=abstract>
- [7] A. Clauset, M. Newman, and C. Moore, “Finding community structure in very large networks,” *Physical Review E*, vol. 70, no. 6, p. 066111, Dec. 2004. [Online]. Available: <http://link.aps.org/doi/10.1103/PhysRevE.70.066111>
- [8] K. Wakita and T. Tsurumi, “Finding Community Structure in Mega-scale Social Networks,” in *Proceedings of IADIS international conference on WWW/Internet.*, Feb. 2007, p. 9. [Online]. Available: <http://arxiv.org/abs/cs/0702048>
- [9] A. Arenas, “Emergence of clustering, correlations, and communities in a social network model,” *arXiv:cond-mat/0309263v2*, pp. 1–5, 2008.

⁵Project number: ICT-257493

- [10] a. Arenas, L. Danon, a. DiÉjaz-Guilera, P. M. Gleiser, and R. Guimerí, “Community analysis in social networks,” *The European Physical Journal B - Condensed Matter*, vol. 38, no. 2, pp. 373–380, Mar. 2004. [Online]. Available: <http://www.springerlink.com/openurl.asp?genre=article&id=doi:10.1140/epjb/e2004-00130-1>
- [11] C. Borgs and J. Chayes, “Exploring the Community Structure of Newsgroups [Extended Abstract],” in *Proceedings of the tenth ACM SIGKDD international conference on Knowledge discovery and data mining*, 2004.
- [12] L. Backstrom, D. Huttenlocher, and J. Kleinberg, “Group Formation in Large Social Networks : Membership , Growth , and Evolution,” in *Proceedings of the 12th ACM SIGKDD international conference on Knowledge discovery and data mining*, 2006, pp. 44–54.
- [13] J. R. Tyler, D. M. Wilkinson, and B. A. Huberman, “Email as spectroscopy: automated discovery of community structure within organizations,” in *Communities and technologies*, M. Huysman, E. Wenger, and V. Wulf, Eds. Deventer, The Netherlands, The Netherlands: Kluwer, B.V., 2003, pp. 81–96. [Online]. Available: <http://dl.acm.org/citation.cfm?id=966263.966268>
- [14] V. Gómez, A. Kaltenbrunner, and V. López, “Statistical analysis of the social network and discussion threads in slashdot,” in *Proceedings of the 17th international conference on World Wide Web*, ser. WWW '08. New York, NY, USA: ACM, 2008, pp. 645–654. [Online]. Available: <http://doi.acm.org/10.1145/1367497.1367585>
- [15] J. Bryden, S. Funk, and V. Jansen, “Word usage mirrors community structure in the online social network twitter,” *EPJ Data Science*, vol. 2, no. 1, p. 3, 2013.
- [16] D. Liu, D. Percival, and S. E. Fienberg, “User interest and interaction structure in online forums,” in *Proceedings of the Fourth International Conference on Weblogs and Social Media, ICWSM 2010*, W. W. Cohen and S. Gosling, Eds. The AAAI Press, 2010.
- [17] T. Anwar and M. Abulaish, “Mining an enriched social graph to model cross-thread community interactions and interests,” in *Proceedings of the 3rd international workshop on Modeling social media*. ACM, 2012, pp. 35–38.
- [18] D. Project, “Activity Streams - a format for syndicating social activities around the web,” 2013. [Online]. Available: activitystrea.ms
- [19] H. Cunningham, “GATE, a general architecture for text engineering,” *Computers and the Humanities*, vol. 36, no. 2, pp. 223–254, 2002.
- [20] D. Maynard, V. Tablan, H. Cunningham, C. Ursu, H. Saggion, K. Bontcheva, and Y. Wilks, “Architectural elements of language engineering robustness,” *Natural Language Engineering*, vol. 8, no. 2-3, pp. 257–274, 2002.
- [21] T. Iofciu, “Finding Communities of Practice from User Profiles Based On Folksonomies,” in *Proceedings of the 1st International Workshop on Building Technology Enhanced Learning solutions for Communities of Practice*, 2006, pp. 288–297.
- [22] L. C. Freeman, “A set of measures of centrality based on betweenness,” *Sociometry*, pp. 35–41, 1977.

Emotion analysis through physiological measurements

Adrian R. AGUIÑAGA ^{a,1}, and Miguel LÓPEZ RAMÍREZ ^a

Arnulfo ALANÍS GARZA ^a Rosario BALTAZAR ^b Victor M. ZAMUDIO ^b

^a *Instituto Tecnológico de Tijuana, Blvd. Industrial y Av. ITR, Tijuana S/N, 22500, Mesa Otay, Tijuana, B.C, México*

^b *Instituto Tecnológico de León, Av. Tecnológico S/N, Fracc. Industrial Julián de Obregon León, B.C, México*

Abstract. There have been several advances in the field of affective computing analysis, however one of the main objectives of the brain computer interfaces (BCI), it is to interact in a natural way between human and machines; The analysis of the emotional state user is very important since it may provide a more suitable interaction generating closest approach, and efficient interaction. Furthermore extent that implementation of systems that can develop an emotional human-machine interface, applications of affective computing, it could widely used to help people with physical or deliberately to analyze and characterize the emotions that may be of interest and provide benefits on a human activity (eg, performance of athletes).

In this paper seven emotional related experiments where development according whit the model arousal / valence model, each experiment corresponds to an evoked emotion from 32 study subjects and contains information the galvanic skin response (GSR), an electrooculogram (EOG) and electromyogram (EMG), for each user, each emotion is evoked by a process audio / visual for 60 seconds, focused generate three emotions (anger, happiness, sadness). Statistical measures are used to create parameters and distances to generate an overview of classification of signals related to an emotion. For information preprocessing is used discrete wavelet transform and statistical parameters (mean, standard deviation, variance) plus a surface filter.

Keywords. emotions, affective computing, physiological, Discrete wavelet transform

Introduction

Computers play an important role in the behavior of users and interactive with the world, however the machines lack of sympathy or interest in the interaction with the user, in recent years the increasing development in mobile technology and the development of increasingly targeted applications to the user, have facilitated the development of applications that generate most natural interaction between the device and the user. Taking advantage of this with the flexibility that hardware design and development have been presented with the increasing accessibility of the costs, the field of human-machine interfaces (HCI) emerged to create a new class of interfaces that allow you to interact with a device in a more natural way, by the analysis of signals collected from a user through

¹Adrian Rodriguez Aguiñaga, Ph.D student, Instituto tecnológico Tijuana, México; E-mail: nefer@live.com

sensors. Currently the technology would allow us to generate models to facilitate empathy in human-computer interaction and development of artificial systems built to interact in a more natural user through mobile devices [1]. Modeling and emotional status classifications for this purpose are the main areas to develop, which in turn would lead to a less state of user frustration when interacting with new technologies.

Psychophysiological signals for this case we are useful in the detection of mental and physical state associated with a cognitive and/or emotional. The processing and analysis of physiological signals through sensors presents a wide range of possibilities, particularly the development of systems that allow us to know the emotional state and take action to correct default either way the device communicates with the user custom or create an environment that benefits the emotional state (eg color changing system environment or creating musical environments based on user preferences) [2].

1. Emotions

One of the main problems in the analysis of emotions is itself the complexity of the concept of emotion, but most researchers agree that emotions are acute affective states that exist in a relatively short period of time and that are related to a particular event, to an object or action [2] [3]. In conjunction with this in psychology, emotions are predominantly described as points in a two dimensional space of valence and arousal model (VAM). This allows us to generate broad categories of emotions, to differentiate between high and low high and low valence or arousal. However, in principle an infinite number of categories can be defined, because the valence and arousal are not necessarily linked is not directly proportional to each other [4] [5] [6] . Although this can not be represented in the VAM, it provide a representation of how it could represent the mixture of emotions as it contains positive and negative at the same time fastened a Cartesian representation.

The VAM allows better discrimination between different emotions. In this work, only three emotions where analyzed selected because are evenly distributed in each quadrant from the Russel model, in the form of high valence high arousal for happiness, low valence arousal such as anger and low valence / low arousal as sadness, as shown in figure 1 . The quadrant high valence and low arousal emotions are related reserve for the state of relaxation and was taken as a reference point and to calculate the metric between the distances between an emotion regarding other statistical characteristics.

2. Methodology

2.1. DEAP Database

Another important problematic in the development and research of behavior and emotional recognition, is the lack of benchmarks measures related to physical or emotional reactions, currently only the IADS (audio / sound), IAPS (visual / image) and BU-3DFE (Inghamton University 3D facial Expression), are to our best knowledge databases generate responses related to emotions in users, however do not contain emotional information of a set of individuals to serve as reference for future research. Another important reference database is DEAP Dataset (-Database for Emotion Analysis Using physiological

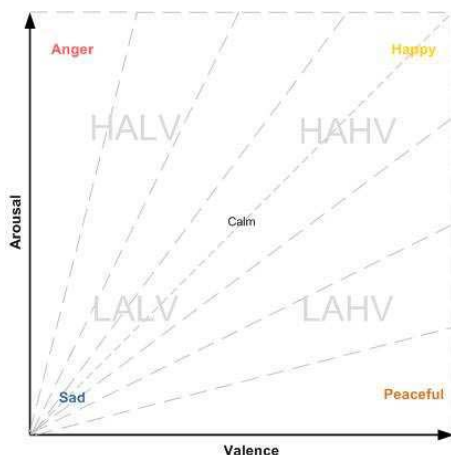

Figure 1. VAM bi dimensional representation for emotions

signals), which is to our best knowledge the most comprehensive database, for collecting survey-based information and generates a wide variety of emotions using technical audio visual, online surveys and information subject status at the time of study realizase the experiment also includes psychological as well as physiological signals plus a video recording of members while performing the experiment [1].

As mentioned in section 1, it is necessary that the space can be divided to be characterized and the DEAP database VAM can be subdivided into four quadrants, low arousal / low valence (LALV), low arousal / high valence (LAHV), high valence / low arousal and high arousal / high valence (HAHV). With the order to ensure diversity of emotions induced [7], an important aspect to highlight on this basis of data is that could be employed as reference of other investigations and other members where conditions of the experimentation could or not be diverse.

2.2. Physiological Measurements

On [8] have shown that the physiological characteristics are altered naturally in the presence of emotions (eg, heart rate, blood pressure, respiratory rate, the galvanic skin response, brain activity and muscle activity tend to suffer variations to be influenced by any emotion). Besides physiological signals are in many cases autonomous and the system that controls this are regularly outside of conscious control of a subject [10].

To properly generate information about emotions in a lab, is necessary to consider create a space with no discomfort and present a good characterization of the experiment one of the most important. But also one of the important aspects is the correct interpretation of the signals, based on the type of experience provided to people and settings control to detect emotional states, this means you have to develop a robust interpretation algorithm signal, which take into account the induced emotion and the reaction of the user in a spatio-temporal process.

However, a system will only be able to determine the emotional state of a user, only if this involves monitoring psycho-physiological measurements in real time in order to create a profile of a user and because the devices to assess direct physiological measures are often considered to be annoying to the user, which created incorrect or unreliable

measurements for analysis, which implies that the simple fact of the study involved in this change. In the affective computing field, there have been some efforts to design discrete measurement technology, known as affective wearable [9], defined these as tolerant systems and the use of sensors and tools to recognition with the least possible interference. This allows us to considerations emotions measurements could be made, particularly for this experiment the following physiological measurements were considered:

- Galvanic Skin Response (GSR).
- Electrooculogram (EOG).
- Electromyography (EMG).

In galvanic skin response (GSR), also often referred to electrodermal activity [10], which is a measure of the conductivity of the skin which represents the influence of the sweat glands under more excitation it produce more sweat, consequently increase the conductivity of the skin. The GSR was chosen because it is a measurement that can be unevaluated by a peripheral, easy to handle and this activity can not be easily controlled by the user. GSR is calculated from the measured signal with a time constant of about 63 seconds per experiment, in this time window are captured GSR signal variations. According to peripheral physiological sensor placement in [1], four electrodes are used to record EMG EOG and four (the zygomatic major and trapezius muscles).

We measure muscle movement using an electromyogram and electrooculogram, which have been shown to undergo alterations individually in the presence of emotions such as stress or surprise [7] [11]. The electrooculogram, relies on the eye-blinking affected by emotional state, and the results are reflected in easily detectable peaks in the signal (eg the rate of eye blinking is another feature, which is correlated with anxiety as a process for the psycho-physiology of emotion) [12] [14], features that could be analyzed for the eye blink rate are energy, mean and variance signal. Electromyography in muscle activity can also be assessed in frequency therefore EMG signals which are a generalization of the muscle action, and found the existence of variations activity peaks enegia or most of the power in the spectrum an EMG during muscle contraction is in the frequency range of 4 to 40 Hz.

2.3. *Experiment development*

Once defined the parameters to be analyzed and generated the abstractions necessary to carry out the analysis, information is made up as follows:

- Raw information.
- Filtering: implement a notch filter from 3.5 to 47.5 Hz and a filter surface (1).
- Wavelet processing: use a wavelet Daubechies 6 to level 3 to multiple signals to generate a signal characteristic.
- Extraction of features: calculate the transform coefficients and store them in an array.
- Statistical analysis: developing statistical calculations of the coefficients of the Transformed (mean, standard deviation, variance).
- Calculate metrics of an emotion to another emotion: calculated based on a euclidean metric distances.
- Deploy and calculate results: graph and calculate results for each statistical data for each user and for each experiment.

3. Feature extraction

Due that a very large amount information would be proceeded at the same time a data reduction and pre-processing task must be performed, to avoid to compute unnecessary data.

3.1. Pre-processing

In the analysis of the signal is necessary to consider the noise, to prevent the loss of potentially useful information, you need to apply filters that allow us to eliminate unwanted information of the experiment, for this analysis was implemented a Laplace filter surface.[15].

The mathematical model of the filter is given as:

$$X_{new} = X(t) - \frac{1}{N_E} \sum_{i=1}^{N_E} X_i(t) \quad (1)$$

where

X_{new} : Filtered signal.

$X(t)$: Raw signals.

N_E : Number of neighbor electrodes.

3.2. Wavelet Transform Analysis

Due to the nature of the signal that is being analyzed and is a biological signal that changes over time the use of the Fourier transform (FT) is inconvenient, because although we can analyze the signal in the domain of the often only possible to analyze the frequency spectrum as a whole without knowing the time of occurrence of each. To resolve this issue, the Short Time Fourier Transform (STFT) can be used, because this transformation maps a time signal into a two-dimensional signal time and frequency, however the drawback is that only the STFT can be known frequency signal comprising the small time windows and the total spectrum or unknown behavior of the signal as time advances.

Often there is a need for better resolution in time at higher frequencies, the wavelet transform is able to cope with this requirement, even though mapping the signal into timescale or time-frequency, because perform a connection between scale, level and frequency. Due that we are working with a biological signal and there is need for time resolution of the frequencies, the implementation of the wavelet transform is desirable since it is able to cope with this requirement, since it is able to perform a mapping of signal time scale. The wavelet transform and its characteristics render it the most appropriate for analyzing this type of a non-stationary signals, based on the expansion and recruitment right through signals and displacement of a single function prototype ($\psi_{a,b}$, the mother wavelet), specifically selected for the signal under consideration.

The mother wavelet function $\Psi_{a,b}(t)$ is give as:

$$\Psi_{a,b}(t) = \frac{1}{\sqrt{a}} \Psi\left(\frac{t-b}{a}\right) \quad (2)$$

where $a, b \in R, a > 0$, where R are the wavelet space.

Parameters a and b are the scaling factor and shifting factor respectively. The only limitation for choosing a prototype function as mother wavelet is to satisfy the admissibility condition:

$$C_{\Psi} = \int_{-\infty}^{\infty} \frac{|\Psi(\omega)|^2}{\omega} d\omega < \infty \quad (3)$$

Where $\Psi(\omega)$ are the FT of $\Psi a, b(t)$, the time-frequency representation is done by filtering the signal several times with a pair of filters to divide the frequency in half additionally, at each level of decomposition. Decomposes to transform approximation coefficients (CA) and the detailed coefficients (CD). Turn on each iteration the approximation ratio is then divided, into new approximation and detail coefficients.[13] as show on figure 2 and figure 3, where the continuous and discrete analysis where performed it respectively; Figure 2, shows the statistical measurements (mean and standard deviation) from the reconstructions coefficients over a 63 seconds signal with a continuous wavelet transform analysis, from a single GSR electrode(sensor), and the Welch scalogram that provides the spectral density from the energy over time. On figure 3, the same signal where analyzed with a discrete wavelet transform, an approximation reconstruction where performed to generate a better perspective of how efficient this method could thread this kind of signals with the half of samples from the signal, however we know that continuous wavelet transform are not suitable for real implementation it gives us a good idea of the signal behavior .

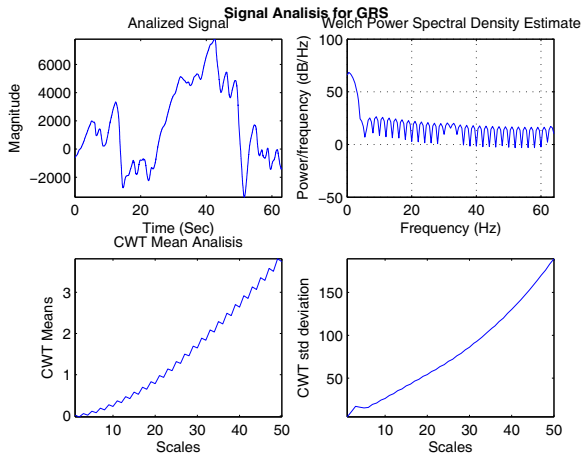

Figure 2. Continuous Wavelet features analysis

3.3. Data reduction

In order to be capable of compute the physiological measurements on efficient time the multi-signal wavelet analysis was made and work with the statistical measurement for the reconstructions coefficients of the wavelet kernel.

- Laplacean Filter : Remove all the baseline noise and smooth the signal.

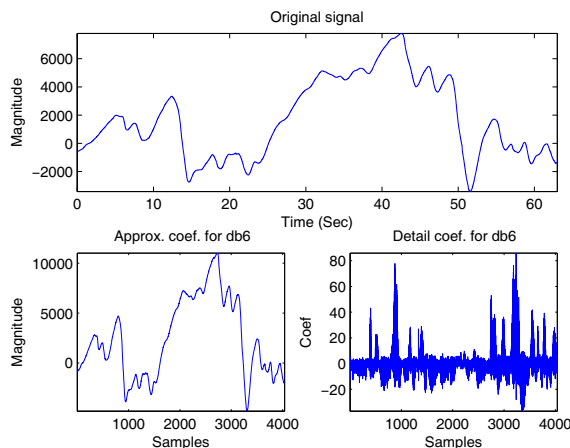

Figure 3. Discrete Wavelet features analysis

- **Band-pass Filter:** All samples, number of local minim in the GSR signal, average rising time of the GSR signal, 10 spectral power in the [0-2.4]Hz bands, zero crossing rate of Skin conductance slow response (SCSR) [0-0.2]Hz, zero crossing rate of Skin conductance very slow response (SCVSR) [0-0.08]Hz, SCSR and SCVSR mean of peaks magnitude as on [7].
- **Wavelet Transform:** Transform the signal using DWT, with a Daubechies 6 at level 3 to perform the characteristics extraction.
- **Coefficient statistical measurements:** Mean, Standard Deviation, Median and Variance where used to perform the grouping of the signals for each related emotion.

4. Results

Analysis for dimension reduction shows a remarkable relationship between anger and sadness for experiments GSR measurements, as can be seen easily in Figure 4 and 5, where the left plot shows the performance of the three emotions with respect that rate behavior over time. This clearly shows a trend in the behavior of the measures taken to emotion and as shown in the other graph the distance between sadness and happiness can be seen in a more clear, also in figure 5 the measurements and distances between emotions can be observed in reference with another for each other emotions.

Moreover, these results are only for GSR analysis, where the trend of anger and sadness has a very similar behavior, as shown in Table 1. However, in figure 6, the analysis of EOG for the same three emotions is observed that the behavior of happy and sad emotions seem to be more related, which is the same case for behavioral results on the analysis of EMG characteristics, as shown in figure 7, where the first sight, anger and sadness tend to behave more like, however as can be seen in Table 2, the percentage of similarity shows that emotions are sadness and happiness a more similar (a close up view of these two emotions tend to have a more stable and anger grows as $x = y$, function).

GRS Statistical Measurements	Sad-Anger (%)	Anger-Happy (%)	Happy-Sad (%)
Mean	68	32	25
Variance	73	26	23
Standar Deviation	75	28	28

Table 1. Similitude from statistical measures of coefficients for GSR (rounded up)

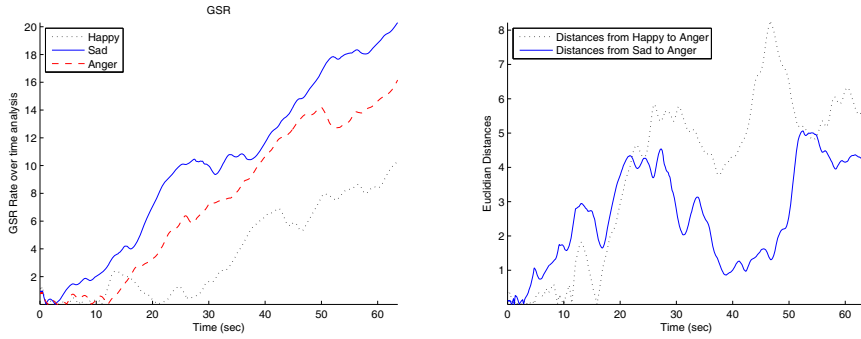

Figure 4. GRS Emotions behavior and distance

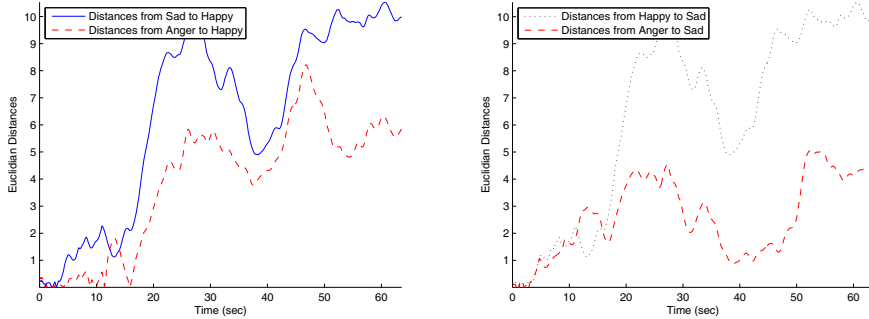

Figure 5. GRS Emotions distance

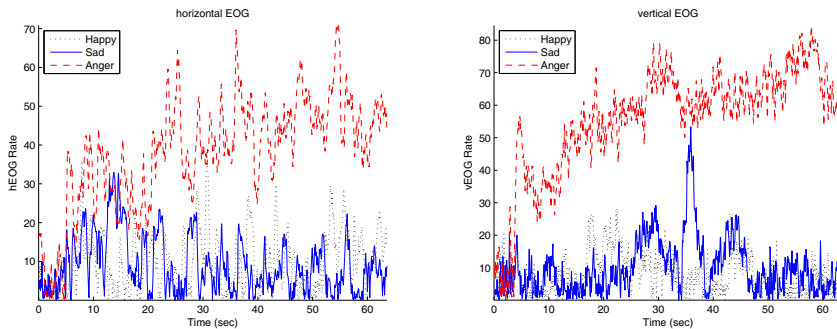

Figure 6. EOG emotions behavior

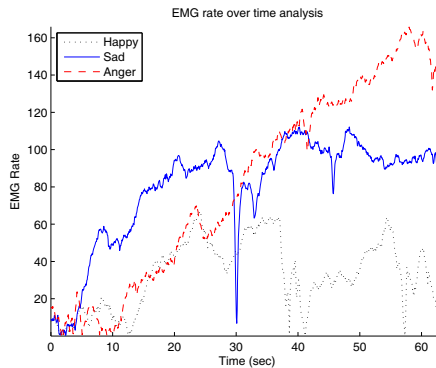

Figure 7. EMG emotions behavior

EOG Stadistical Measurements	Sad-Anger (%)	Anger-Happy (%)	Happy-Sad (%)
Mean	32	34	77
Variance	30	36	75
Standar Deviation	28	38	79
EOG Stadistical Measurements			
Mean	25	19	85
Variance	23	15	87
Standar Deviation	24	20	85

Table 2. Similitude from statistical measures of coefficients for EOG and EMG (rounded up)

5. Conclusions

A close similarity has been found in the emotions of sadness and happiness, however as one of the mayor issues in the process of emotion recognition is the lack of reference, since at present the IADS (audio / sound), IAPS (visual / image) and BU-3DFE (Ing-hamton University 3D facial Expression), are some of the most common databses to analyze, it exists as a benchmark to compare results, which creates the need to generate a point reference to improve emotional research on physiological processes. As this occurs, the results can only be valid on the basis of data that a single group or set of researchers and may not be valid between one and another.

On the other hand using wavelet analysis as demonstrated offers researchers a superior alternative and viable for the analysis of biological signals related to an emotion, the use of wavelet analysis provides a greater power to resolve transient events and a range of simultaneous frequency in this case.

References

- [1] A. Savran, K. Ciftci, G. Chanel, J.C. Mota, L.H. Viet, B. Sankur, L. Akarun, A. Caplier, and M. Rombaut, *Emotion Detection in the Loop from Brain Signals and Facial Images*, Proc. eNTERFACE, July 2006.
- [2] Fua, K., Horswill, I., Ortony, A. and Revelle, W. "Reinforcement sensitivity theory and cognitive architectures". In *Technical Report of the Symposium on Biologically Inspired Cognitive Architectures, AAAI Fall Symposium Series, Arlington, VA, November 5-7. (2009)*

- [3] Ortony, A., Norman, D. A., and Revelle, W. "Affect and proto-affect in effective functioning". In J.M. Fellous and M.A. Arbib, *Who needs emotions: The brain meets the machine*. New York: Oxford University Press.2005
- [4] Ortony, A., Revelle, W. and Zinbarg, R. " Why Emotional Intelligence needs a fluid component". In G. Matthews, M. Zeidner and R. D. Roberts (Eds.). *The science of Emotional Intelligence*. Oxford University Press.2007
- [5] Russell, James . "A circumplex model of affect". *Journal of Personality and Social Psychology* 39: 1161-1178. 1980
- [6] P. Ekman, W.V. Friesen, M. OSullivan, A. Chan, I. DiacoyanniTarlantzis, K. Heider, R. Krause, W.A. LeCompte, T. Pitcairn, and P.E. Ricci-Bitti, *Universals and Cultural Differences in the Judgments of Facial Expressions of Emotion*, *J. Personality and Social Psychology*, vol. 53, no. 4, pp. 712-717, Oct. 1987.
- [7] J.-S. Lee, A. Yazdani, T. Ebrahimi, T. Pun, A. Nijholt, I. Patras, *IEEE Transaction on Affective Computing*, "DEAP: A Database for Emotion Analysis using Physiological Signals", S. Koelstra, C. Muehl, M. Soleymani, 2011
- [8] Guanghua Wu,Guangyuan Liu, Min Hao ."The analysis of emotion recognition from GSR based on PSO"2010 International Symposium on Intelligence Information Processing and Trusted Computing, (2010).
- [9] Picard, Rosalind. "Affective Computing". MIT Press, p. 93-94, 1997
- [10] Anderson C.W and Sijercic Z. "Classification of EEG signals from Four Subjects during Five Mental Tasks". *IEEE Proceedings on Engineering Application in Neural Networks*, pp. 407-414,(1997).
- [11] P. Lang, M. Greenwald, M. Bradely, and A. Hamm, *Looking at pictures - affective, facial, visceral, and behavioral reactions*, *Psychophysiology*, vol. 30, no. 3, pp. 261-273, May 1993.
- [12] S. D. Kreibig, *Autonomic nervous system activity in emotion: A review*, *Biological Psychology*, vol. 84, no. 3, pp. 394-421, 2010
- [13] Merzagora, A.C., Bunce, S., Izzetoglu, M. and Onaral, B. *Wavelet analysis for EEG feature extraction in deceptive detection*. *IEEE Proceedings on EBMS*, 6, 2434- 2437, 2006
- [14] Blankertz.B, R. Tomioka, S. Lemm, M. Kawanabe, and K.R. Muller;"Optimizing Spatial filters for Robust EEG Single-Trial Analysis", *IEEE Transactions on Signal Processing*, vol 25, no 1, pp. 41-56, (2008).
- [15] Joyce H.D.M. Westerink, Egon L. van den Broek, Marleen H. Schut, Jan van Herk and Kees Tuinenbreijer;"Computing emotion awareness through galvanic skin response and facial electromyography",*Springer Science and Business Media*, 2008

1st International Workshop on Applications of Affective Computing in Intelligent Environments (ACIE'13)

Faiyaz Doctor (Coventry University, United Kingdom)

Victor Zamudio (Instituto Tecnológico de León, Mexico)

This page intentionally left blank

Introduction to the proceedings of ACIE 2013

This section contains the papers presented at the 1st International Workshop on Applications of Affective Computing in Intelligent Environments (ACIE 2013).

The aim of this inaugural workshop is to bring together research in Intelligent Environments (IEs) and current developments in the area of Affective Computing (AC). With AC we seek to explore new approaches that enable the recognition, modelling of human physiological and affective states. These can be used in context of IEs to develop unobtrusive natural communication between humans and environmental artefacts as well as enhance the ability of the environment to understand the users' needs based on their emotive responses. The workshop provides an opportunity to promote and demonstrate how recent developments of unobtrusive physiological sensing systems are being used in interesting and novel approaches for eliciting physiological information; modelling and identifying emotional responses, to enhance IE based applications. The conceptualisation, design and deployment of such systems draw on interdisciplinary knowledge from the fields of computer science, biological signal processing and artificial intelligence as well as psychology, sociology and ergonomics which are fundamental to intelligent human centred systems.

We deeply appreciate the Intelligent Environment 2013 (IE'13) conference organizers for their help on hosting this event. We wish to express our sincere thanks to the Program Committee for their thorough reviews and support along with the IE'13 workshop chairs.

Faiyaz Doctor and Victor Zamudio
Co-chairs ACIE 2013

Social Awareness in Pervasive Communities for Collaborative Work

Christopher LIMA¹, Mário ANTUNES, Diogo GOMES and Rui AGUIAR

Instituto de Telecomunicações

Universidade de Aveiro, Aveiro, Portugal

Abstract. Future pervasive environments will take into consideration physical and digital social relations. Nowadays it is important use to collective intelligence, where the interpretation of context information can be harnessed as input for context-aware applications, especially for group collaboration. The use of collective intelligence represents new possibilities but also new challenges in terms of collective information for adaptability and personalization in intelligent environments. This paper presents a collaborative context-aware framework focusing on social matching capabilities for session formation in collaborative activities.

Keywords. Pervasive computing, social matching, collaboration.

Introduction

With the advent of Web 2.0, various social networking sites emerged in the present scenario of the internet (E.g. Facebook, LinkedIn, Twitter, etc.). The information retrieved from these social sites can be useful for pervasive or ubiquitous systems, where the changes of environment and/or context are important to offer powerful ways of working and communicating.

Ambient intelligence has matured greatly, mainly due to mobile devices and sensors evolution. Combining ambient intelligence with social networks creates a pervasive environment in which real-world and virtual social information can be utilized as context information. The context refers to a set of conditions (e.g. temporal, presence, location) that may be used by applications to dynamically adapt its behaviour.

Environments such as smart spaces are aware of context, enabling users to access computing resources to perform their activities [1]. In addition, several of these activities in smart spaces may involve multiple users collaborating in common tasks. The CSCW (Computer Supported Cooperative Work) field has various types of applications for group tasks including conference, development and workflow environments. However, context-aware CSCW applications research has only reached recently pervasive systems. The trend is towards the use of collective intelligence, where interpretation of context information related to the group relations should be harnessed as input for such collaborative applications in these environments.

¹ Instituto de Telecomunicações, Universidade de Aveiro - Campus Universitário de Santiago, P-3810-193, Aveiro – Portugal; Email: cviana@av.it.pt.

While the pervasive environments can support large and small groups, usually collaborative activities happen often in small groups of up to 10-15 people [2]. A survey applied by SOCIETIES project in April 2011 at Intel's Lab, Ireland indicate that small dynamic groups based on criteria such as location are a desirable feature to the majority of interviews [3]. The questionnaire also demonstrates that almost all participants agreed to share their professional information such as: business cards, LinkedIn profile, educational information and expertise areas.

Take into account an enterprise scenario, where many researchers and projects have workshops at an IT company campus. A community can be created for IT campus staff and a smaller community for each project. For this scenario, our framework will provide, for instance, an integrated support system to optimize the infrastructure for collaborative work as session meeting management and dynamic groups' formation for breakout sessions.

In this paper we present a social matching for pervasive communities focusing in support collaborative sessions. The social matching component is part of a framework that provides adaptability for communication, coordination and relationships to CSCW in enterprise scenarios. The goal is to demonstrate that CSCW activities can benefit from using individual information merged with social computing in collaborative activities for enterprise environments.

1. Pervasive Communities

A smart space community envisages the integration of pervasive and social areas to provide personal smart spaces that can move along the users providing group capabilities following the users' interests. Figure 1 illustrates three pervasive communities where the community one comprises community two and three.

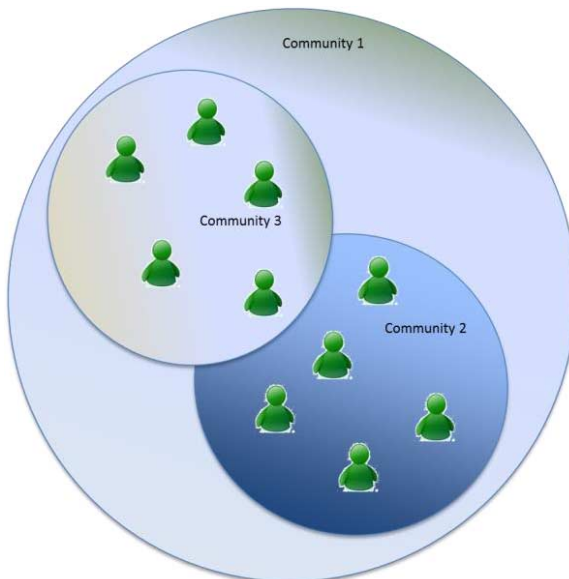

Figure 1. Example of three pervasive communities

The SOCIETIES² project is researching the intersection of both areas to design a system with features such as single/multi-user pervasiveness, personalization, dynamic community formation, privacy, context management and social networking as context sources.

There are several criteria's that can be used to form a community of individuals or organizations such as sharing same location, have same or similar preferences, share interest and share social relationships. All the users by default need to accept beforehand the privacy policies of the specific community to participate (e.g. age, location). The policies can be defined by the community creator or by the administrator elected by the users.

2. Related Work

Opportunistic social matching is a class of systems that matches users independently of a user request [4]. The matching is typically done based on shared interests and similarity found among the individuals, where people are considered good matches with high affinity in common. Differently from group recommenders systems, social matching systems focus on suggest people instead of items. Some system attempt to tackle groups in pervasive environments in the literature [5], [6], [7]. However, these solutions do not take into consideration the possible synergy between physical world and virtual social interaction.

In this regard, group detection methods in the literature are usually based on graphs where nodes represent the individuals and the links some interaction or similarity among the individuals. The relationship behaviour in this type of networks is categorized into static and dynamic [8]. The static analysis the relationships at a particular time to group individuals through the links available, while the dynamic study the network to find modular structures along the time. The second is a challenging task since it is important to take into account many aspects as links and nodes appearing/disappearing at different time points [9].

3. Social matching for Collaborative Work

We implemented a framework to deal with collaborative session's formation on the pervasive communities. Generally, pervasive systems such as PERSIST³, C-CAST⁴ have a specific component to manage context, allowing the system to capture and retrieve user information. The framework is responsible for gathering context information from the users through heterogeneous sources that can range from mobile sensors to SNS (Social Networking Site). The mobile devices for instance provide location and availability. On the other hand, SNSs can provide information related to user profile such as interests, professional position and company. Thus, the main focus of the framework resides in context management, knowledge extraction and automatic adaptation, abstracting the concern to deal with context information sources.

² <http://www.ict-societies.eu/>

³ <http://www.ict-persist.eu/>

⁴ <http://www.ict-ccast.eu/>

4. Framework Design and Implementation

In [10] we present some relevant context information categories appropriated for the framework describing three enterprise scenarios. Some of the categories which may be used include: geographic location, current availability, current computational (mobile/desktop) resources and professional interests.

To model the individuals and interaction we choose represent them in graph. As a tool we adopted the Neo4j⁵ which offers a graph-oriented model for data representation. In this way, the graph analysis occurs dynamically, enabling the data be updated over time by the context sources.

We divide the information into separate categories: long-term and short-term. The long-term information is comprised by data that does not change often such as: job position, areas of interests, skills. While short-term information comprises data that changes frequently such as location and availability (e.g. user busy, away).

The collaborative sessions in the framework are composed of members, roles and applications in common (e.g. chat, audio conference). A set of rules manages when a session needs to start and invite the participants. For instance, if at least two people are in the same location and work at the same department and have the same interests then start a session. The framework session is part of a community is in charge to check context information changes in different intervals for long-term or short-term types.

Additionally, the rules are dynamic and can be created by the administrator before the sessions start or in runtime.

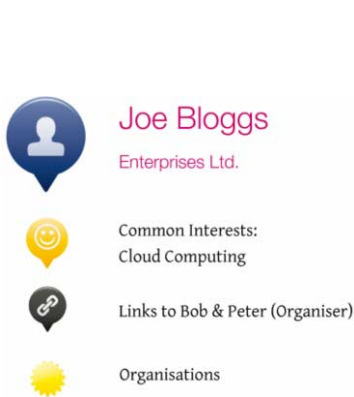

Figure 2. Participants with same similarity are invited to join the collaborative session⁶.



Figure 3. Using information available from SNS and the individual the social match mechanism verifies the similarity among the members⁶

Figure 2 exemplify a user profile that belongs to a community. Figure 3 presents a suggestion example based on location and data provided from SNS in the user's tablet device. In this case for example it is possible to start a collaborative session inviting the users for an online chat.

In order to extend the context information collected from the context sources, the framework performs an enrichment of context depending on the nature of the data. The

⁵ <http://neo4j.org/>

⁶ Taken from http://www.ict-societies.eu/files/2011/11/D8.1_public.pdf.

information can be expressed in numeric or text values. The numeric values can be enriched using historical information available, as an example it can be used to generate temporal series. This is helpful in case certain events to not occur regularly.

While in text values it is possible to assign similarities among the persons in graph. This similarity enables to associate weights between person nodes and is calculated by dividing the matched information by the total available. This is applied for both and the result is divided by two as represented below:

$$S = ((\text{matched context}/\text{context node1}) + (\text{matched context}/\text{context node2}))/2 \quad (1)$$

In addition, the texts values are submitted to external sources of Natural Language Processing (NLP) for semantic analysis, returning synonymous words that are aggregated with the existing information. This enrichment provides knowledge to create rules decision that occurs in the adaption layer. Figure 4 presents the individual nodes after the analyses. As an example, the two nodes on the top of figure 4 has value 0.33 with $((1/3) + (1/3))/2$.

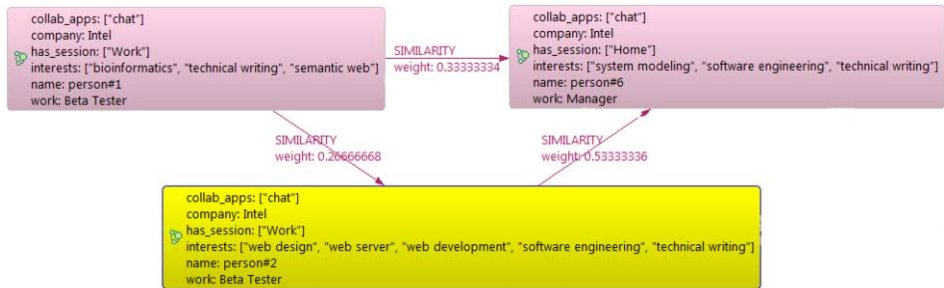

Figure 4. Sample of graph individuals and their similarities.

In runtime the framework is requested to report which the thresholding should be used to select relevant persons for the given similarity. This method is called automatic thresholding and it is often used in image processing for segmentation [11]. The thresholding mean value is calculated based on the weights assigned previously. The weights values can be verified in the arrows among persons as illustrated in Figure 3.

The context information is checked automatically and periodically by the awareness monitor framework, depending on their nature. Long-term is verified in longer intervals, while short term is observed in real-time.

An important aspect raised by the interviewees in the survey is regarding the privacy. First, they highlighted the importance to review group's members before joining a session, avoiding being automatically added and causing offence by removing themselves from the group afterwards. Secondly, is related to users or services trying to access their context information.

The first issue was addressed presenting an invitation to join a session presenting the context information used to match the person by the framework. In cases where the session already exists, it is possible to present who previously joined session, however for cold starts sessions it is possible to introduce the members in which have been invited. For the second issue the SOCIETIES platform presents a notification asking whether the user allows or denies the access of specific context information. At first glance this could cause problems for the framework retrieve information, however as described in Sections 2 almost all users agree to share their professional information.

5. Conclusions and Future Work

We are developing a framework using context information and reasoning techniques. The framework will be applied in collaborative tasks for pervasive communities. The main focus will be on enterprise domain, especially taking advantage of information available on SNS and real-world interaction. The framework shall support sessions, coordination, tools, hierarchies and role of users to be able to provide recommendations, suggestions and pro-activity behaviour.

As future work we will conduct case study in a real enterprise scenario, specifically in a conference. The conference will be held in Intel's Campus, Ireland. The enterprise scenario analysis will be collected in September 2013 and will comprise a chat application for the participants. The scenario has been designed from a storyboard refined by a questionnaire that was conducted with Intel employees in 2011. Many challenges remain for interpretation of existing context related to individuals and groups for CSCW. In the future, the authors intent to investigate other relevant methods for interpretation and analyses of context. Another future work is to focus in the session management and the floor control aiming to provide an intelligent dissemination mechanism.

Acknowledgements

The authors wish to thank colleagues of SOCIETIES project, without whom this paper would not have been possible. The presented research is supported by FCT - Fundação para a Ciência e a Tecnologia (SFRH/BD/69381/2010).

References

- [1] I.Roussaki, N. Kalatzis, K. Doolin, N.K.Taylor, G.Spadotto, N.Liampotis and H.Williams, Self-Improving Personal Smart Spaces for Pervasive Service Provision. In *Towards the Future Internet*, IOS Press, (2010), 193-203.
- [2] B. Farshchian, M. Divitini. Collaboration Support for Mobile Users in Ubiquitous Environments. *Handbook of Ambient Intelligence and Smart Environments*, (2010), 173-199.
- [3] SOCIETIES Public Deliverable-Trial Report - http://www.ict-societies.eu/files/2011/11/D8.1_public.pdf.
- [4] T. Terveen and D. W. McDonald. Social Matching: A Framework and Research Agenda. *ACM Trans. Comput.-Hum. Interact.* 12, 3 (2005), 401-434.
- [5] Kumar M., et al., PICO: A Middleware Framework for Pervasive Computing. *IEEE Pervasive Computing*, Vol.2, No.3, (2003).
- [6] E.M. Meyer, D. Wichmann, H. Büsch, S. Boll, Location-based Mapping Services to Support Collaboration in Spatially Distributed Workgroups. *4th International Conference on Collaborative Computing: Networking, Applications and Worksharing*, (2008).
- [7] S. Foell, P. Boessling, D. Linner, I. Radosch, S. Steglich. Self-Organizing Pervasive Online Communities. *Autonomous Decentralized Systems. 8th International Symposium*, (2007), 403-410.
- [8] S. Fortunato. Community Detection in Graphs," *Physics Reports*, vol. 486, no. 3-5, (2010), 75-174.
- [9] H. Sundaram, Lin Yu-Ru, M. De Choudhury, A. Kelliher. Understanding Community Dynamics in Online Social Networks: A Multidisciplinary Review. *Signal Processing Magazine IEEE*, vol.29, no.2, (2012), 33-4.
- [10] C. Lima, D. Gomes, R. Aguiar. Pervasive CSCW for Smart Spaces Communities. *Pervasive Computing and Communications Workshops (PERCOM Workshops)*, (2012), 118-123.
- [11] Sahoo P. K., Soltani S. and Wong A.K.C. A Survey of Thresholding Techniques. *Computer Vision, Graphics and Image Processing*, vol. 41, (1988), 233-260.

Game Based Monitoring and Cognitive Therapy for Elderly

Javier NAVARRO ^{a,1}, Víctor ZAMUDIO ^a, Faiyaz DOCTOR ^c
Carlos LINO ^a, Rosario BALTAZAR ^a, Columba MARTÍNEZ ^a, Jaime TORRES ^b,
Luis BERMÚDEZ ^b, Bertha GUTIÉRREZ ^b

^aInstituto Tecnológico de León

^bFundación Alzheimer León

^cCoventry University

Abstract. As the proportion of older adults grows, the number of special care provisions to help individuals with declining cognitive abilities needs to also increase. Information Communication Technology (ICT) is beginning to play an increasing role in facilitating the work of specialists to support and monitor individuals with cognitive impairment within their everyday environments. In addition, advances in artificial intelligence and the development of new algorithmic approaches can be used to approximate the computational processes of human behaviour in different circumstances. In this paper, we report on the development of a software system using game based therapies for older adults in Mexico suffering from cognitive impairment, where this system has been deployed in a unique day therapy centre. We further propose an evaluation module based on using AI approaches and affective sensing to monitor and detect significant changes in performance cognition that might indicate a possible cognitive decline.

Keywords. Cognitive Impairment, Alzheimer, Computer Assisted Therapy.

Introduction

The world's elderly population is growing significantly and coupled with this, the number of elderly people with cognitive impairment too (see Fig. 1). According to data from the Alzheimer's Association, in 2010 the world's population of older adults over 60 was estimated at 758.54 million people, of which 35.56 million (4.7%) had dementia. However, a significant increase is expected in the coming decades, where this number will reach 65.69 million by 2030 up to 115.38 millions by 2050 [2]. In the case of Mexico, the National Institute of Neurology and Neurosurgery (INNN) reported in 2010 more than 350,000 people affected by Alzheimer's disease and that annually 2,030 patients died from it [3].

Furthermore, according to INEGI (Mexican Institute of Statistics, Geography and Informatics), in the specific case of Mexico in 2000 the number of people over the age of 65 reached a total of 4,750,311. Population projections rank Mexico among 10 countries that is set to rapidly increase number of elderly people over the next 30 years, which is projected to reach more than 15 million by 2030 [1].

¹ Author: Francisco Javier Navarro Barrón. iscjnavarro@hotmail.com. Division of Research and Postgraduate Studies, Instituto Tecnológico de León.

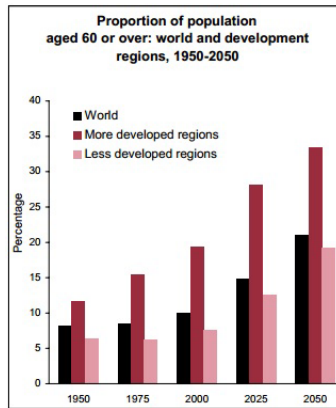

Figure 1. Proportion of population aged 60 or over 1950-2050 [17].

Due to the growing rate of the ageing population, government funds may be insufficient to cover all their needs. Additionally, it is important to notice that not all the people will be able to qualify for a pension (and the probability of finding a part-time job decreases dramatically with age). For these reasons the Institute of Memory (supported by The Alzheimer Institute of Leon Guanajuato, Mexico) was established in 2005 due to the lack of specialized institutions in the treatment for patients with cognitive impairment, with the aim of creating an interactive program of cognitive stimulation to enable both the intervention and prevention of cognitive decline in the elderly.

The Institute offers various services such as a unique Mental Spa (with different activities such as workshops for elderly, and cognitive stimulation programmes), workshops for carers, senior nutrition and diet tips, psychotherapy and support groups, and a wide range of group activities such as cine club, ballroom dance, swimming lessons, and tai-chi among others.

Observing a patient's activities can be used to monitor and assess cognitive impairment and decline. For example, early stages of cognitive impairment may cause forgetting certain steps in familiar tasks or difficulty in performing new and complex tasks. As such in February 2011 the Alzheimer Foundation Leon (FAL) proposed a joint venture with Leon Institute of Technology (ITL) to develop a software system called *Mente Activa* that allows the use of therapies through cognitive stimulation exercises to benefit FAL patients who suffered from cognitive impairment or dementia.

An initial version of this system has now been deployed and is being assessed by patients at the Memory Institute. An additional need to monitor patient's cognition both during the therapy sessions and remotely from home has been identified as useful for diagnosing cognitive impairment and monitoring progression of cognitive decline. We therefore further propose an extension to the existing system through the incorporation

of an intelligent evaluation module that would analyse patient performance data acquired from the *Mente Activa* system. We also consider the use of affective sensing technologies that could be used to unobtrusively monitor certain physiological parameters for monitoring emotive drive aspects of cognition such as engagement and arousal or frustration while interacting the simulation exercises. These might give us a more accurate picture of the patient's cognitive abilities, progressive decline of these abilities, to facilitate more targeted support.

This paper describes the development and deployment of the software system and current work on the integration of an intelligent evaluation module to facilitate proper monitoring of patients progressive conditions at both the treatment centre and at home. The rest of the paper is organised as follows. Section I introduces the challenge faced and the important role of the technology. Section II is about some popular game-based proposals for cognitive treatment and its main features including disadvantages for Latin-American context. Section III points out our approach in order to clarify its structure and how it is organized. Section IV is related to an evaluation module that is being developed in order to detect important interaction changes on the user's performance with the software and its activities. Section V defines one of the main targets of the evaluation module. In section VI the conclusions and future work of this research is presented.

1. COGNITIVE IMPAIRMENT

1.1. *Dementia*

Dementia is a term used to describe various different brain disorders that have in common loss of brain function which is usually progressive and eventually severe. There are over 100 different types of dementia. The most common are Alzheimer's disease and vascular dementia. People with dementia have particular problems with their short-term memory forgetting consistently recent things, losing the sense of time and place [4].

1.2. *Alzheimer*

Alzheimer's disease is a progressive and fatal disease of the brain. It is a degenerative disease of the brain that leads to a condition called dementia. Dementia is a general term used to describe the loss of memory and mental abilities severe enough to affect daily life [5].

1.3. *Technology applied in cognitive impairment*

While human caregiving cannot and will not be replaced, assistive technologies that can supplement human caregiving have the potential to improve the quality of life for both older adults and their caregivers. In particular, assistive technologies now being developed may enable older adults to "age in place," and remain living in their homes

for longer periods of time. A number of systems have been developed (for example Activity-Guidance Systems [22] or game based assisted physical therapy [23]) for helping people compensate the physical and sensory deficits that may accompany aging, especially older adults who are grappling with cognitive decline.

The Assistive Technology applied on interactive games can assist older people with cognitive impairment to measure cognitive performance by monitoring a person, and also they can be benefit: (1) by providing assurance that the elder is safe and is performing necessary daily activities, and, if not, alerting a caregiver; (2) by helping the elder compensate for her impairment, assisting in the performance of daily activities; and (3) by assessing the elder's cognitive status. There are some projects that support these facts, and they have shown that older adults enjoyed these activities because it incorporates aspects of cognition such as short-term memory and strategic planning that are directly relevant to the performance of activities of daily living [6].

2. RELATED WORK

There are several cases of technology-based tools focused on helping and supporting cognitive therapy; however not all of them are currently available on the market.

2.1. *Smart Brain*

Smartbrain is software developed in Spain, with an interactive multimedia approach that develops cognitive abilities (memory, concentration, language, recognition, calculation, etc.) of people with mental deterioration caused by aging, brain injury, mild and moderate neurodegenerative diseases (Alzheimer, Parkinson, etc.) or dementias [7]. With this software, specialists can define custom treatment plans for their patients and they can perform the activities indicated from home, without travelling to a specialized centre.

This system allows patients to develop cognitive skills. However, it's application in the case of Mexico has the following disadvantages: the software handles an European context, which is meaningless to Mexico or Latin American population. Due to the previous, in some cases the concepts and activities could have different meanings. Additionally the system does not consider historical or cultural facts rooted in Mexican or Latin-American context. Finally, Spanish accent is different from Mexican accent.

2.2. *DIANA*

DIANA (DIAGnóstico Neuropsicológico Automatizado by its Spanish acronym) is a Cuban neuropsychological evaluation software, fully automated and developed by the Centre for Neuroscience of Cuba. This software enables management of customized versions of 27 traditional neuropsychological tests that evaluate major cognitive domains and includes a task to explore the state of the affective functions. Among the best known are the Continuous Performance Task, Path with Milestones, Digits and

Symbols Pairing, Pattern Matching, Estimation of speed, Stroop Test, Wisconsin Card Draw Categories Training test [8].

Despite the fact this software considers a Latin American context, one of the main disadvantages is that this software has not been updated (it was originally launched to the market in 1996), therefore it could be considered obsolete, and unfortunately is not on the market anymore.

2.3. *Lumosity*

Lumosity is a brain training program based brain games and exercises developed by an American company. Based on the concept of "neuroplasticity" (the brain's ability to learn and adapt to receiving an appropriate stimulus) games and exercises are designed to train and improve: memory, attention, processing speed and cognitive control [10]. However, this software has two main disadvantages: the system was designed to help people in general to improve their memory and ability to learn; it is not fully adapted to patients with some cognitive impairment. Additionally, the personal license to use the online system requires monthly payments which does not apply to groups of persons or institutions.

3. PROPOSED APPROACH

Although there are a number of systems on the market (Smartbrain & DIANA) specifically designed for supporting specialists and patients in the treatment of cognitive impairment, in the case of Mexico in particular, these tools are not fully adaptable to language specific customs and usages (the use of European context for the exercises and activities, the lack of historical and cultural facts related to Mexico, and Spanish accent). This makes such tools almost impossible to use as a support system for patients suffering from cognitive decline. Most patients are also unfamiliar with the use of computers, mouse, etc. Due to the previous, in 2011 Leon Institute of Technology in collaboration with the Alzheimer Institute of León began the developing of cognitive stimulation software called *Mente Activa*.

3.1 *Mente Activa*

Mente Activa is a software for the prevention, detection, evaluation and monitoring of older adults with cognitive impairment and dementia. The software allows cognitive stimulation through the use of interactive games specially designed by psychologists, running on computers with touch screen and multimedia items.

The design, planning and development of *Mente Activa* required the collaboration of a multidisciplinary team, initially formed by five psychologists, one neuropsychologist, one neurologist, one graphic designer and two experts on education.

The computer programming and implementation was made by a team of programmers from Leon Institute of Technology. These students, from different semesters and chosen due to their programming skills and interest on participating in a real development problem, were coordinated by a group of professors and researchers from the ITL.

3.2 Software Features

a) Design

The system was designed to be as user friendly and intuitive as possible to the user, taking into account that the common denominator of the people who will use it are not familiar with the use of these technologies. The software therefore makes a wide use of multimedia elements such as images and audio (see Fig. 2).



Figure 2. Screenshot of the administrator module.

b) Developed Modules

The following modules have been implemented as part of the system:

1. User Module: In this module all the information related to every user (patient) is managed: personal data, additional information, status, medication, medical history, substance abuse, diagnostic.
2. Module groups: this module manages the groups created by the administrator.
3. Preview module: this module displays different exercises according to several criteria: cognitive function, activity type, and level.
4. Template Module: in this module a template of a set of exercises can be created in order to define a personalised stimulation plan.
5. Play module: is the module which actually runs and displays the exercises defined in the template module.

It is noteworthy that the exercises are divided primarily by type of cognitive stimulation [12, 13] based on seven key areas: language, gnosis, executive functions, calculus, attention, memory and orientation (see Fig. 3).

Language	Gnosis	Executive Functions
Is a code of sounds or graphics that are used for social communication among humans.	Knowledge gained through the development of sensory experiences.	Defined as processes that associate ideas, movements and simple actions to guide the resolution of complex behaviors.
Calculus	Attention	Memory
Implies aspects of basic concepts of mathematics and cognitive development, operating performance, reasoning, deduction, as well as perceptual skills.	It is a function by which a stimulus or object is in the focus of consciousness, accurately distinguished from the rest, by displacement, attenuation or inhibition of irrelevant stimuli.	Is the faculty of the brain that records new experiences, and remember other previous.
	Orientation	
	Ability to establish relationships between events and objects in space.	

Figure 3. Cognitive stimulation is based on seven areas: language, gnosis, executive functions, calculus, attention, memory and orientation.

Associated to each exercise, an alphanumeric nomenclature was created. This code was formed in the following order: the corresponding mental function (e.g. G for Gnosis), the number of exercise, the level of difficulty (on a scale of 1 to 10) and the number of the exercise.

3.3 System deployment

The software *Mente Activa* makes use of MySQL as management database system, and Java as programming language. It also included the Java Runtime Environment & Java Virtual Machine [21]. The system was specially designed for interacting with the user through a touchscreen, being that most of the users on the third age are not really acquainted about the usage of computers, so all the activities are focused on being intuitive and easy to understand. In Figure 4 we can see some examples of activities (according to Fig 3. distribution). In Fig. 5 a user interacting with the touchscreen is shown.

4. EVALUATION MODULE

Facilities at the Memory Institute, include two modules, one of these, is dedicated to the day centre, where patients receive comprehensive treatment, including cognitive stimulation, among others. In this sense, the incorporation of an intelligent module is a

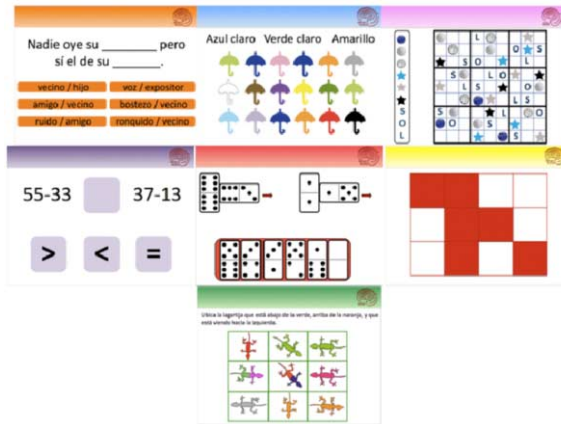

Figure 4. Examples of some activities, according to Fig. 3.



Figure 5. Example of a user interacting with the software.

pressing need, because of the amount of patients being cared for and the requirement for proper monitoring of patients within both the treatment centre. There is also a need to provide a means of allowing remote monitoring of patient at home due to the fact the in many cases these patients live alone with periodic contact with relatives and hence are more vulnerable to their condition worsening as well as other health related problems such as developing depression and injury or hospitalization caused from accidental falls.

An increasing number of devices rely on Artificial Intelligence (AI) and other advanced computer-based technologies. A range of artificial intelligence techniques has been used in the design of advanced assistive technologies. Examples include text-to-speech systems for people with low vision; a digital programmable hearing aid that incorporate a rule-based AI system to make real-time decisions among alternative signal-processing techniques based on current conditions; and jewellery like device that allows people with limited mobility to control household appliances using simple hand gestures. In addition, significant research has been done to design obstacle-avoiding wheelchairs, among several other applications [6].

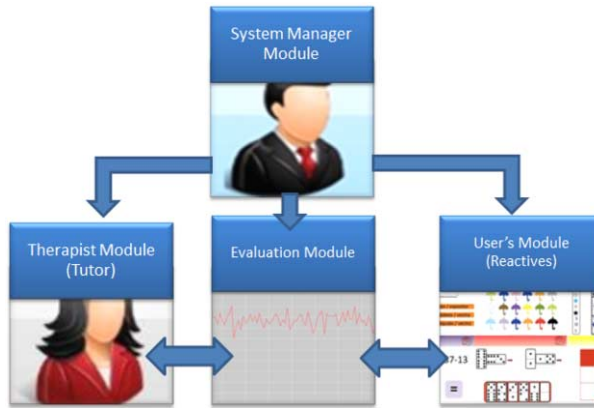

Figure 6. Propose of Software Restructure.

As we mentioned previously, our system can be used to detect changes on the performance of the user, and this could help in the early detection of dementia and Alzheimer. At the moment we are working on the design and implementation of an intelligent module that analyses the performance of a user, based on the execution of the game and the emotional state of the user, allowing automatic feedback to the user. This could be visualized in a better way in Fig. 6, where we can see the hierarchical dependencies of the modules.

For this problem, it seems to be necessary a support tool, with the aim of provide the characteristic therapy data to the specialist and suggest a series of exercises based on performance. Given that therapeutic monitoring can be insufficient due to shortage of specialists, the quality of the therapy can decrease.

Due to the necessity of recognizing the emotional state of the user through the interaction with the different activities, we will gather and analyse the electro dermal activity using a skin conductance meter device, as it has been found that this signals are correlated with the individual's emotional state. Using this technique, the system can detect alterations associated with emotion, cognition, and attention [24] that could be very useful in the selection of activities specially designed for the user's needs.

The development of the proposed performance evaluation module will involve the analysis and evaluation of a number of different AI algorithms that allow us to monitor the user's characteristics and performance on the simulation exercises. At current phase, we are analysing these following algorithms: Artificial Neural Networks, given that there is evidence demonstrating that it is possible for a computer system to recognize patterns of human behaviour through the interaction with a smart environment using neural networks as classifiers [15]. Also we are considering Fuzzy Logic, because the analysis of the behaviour and performance of humans involves uncertainty, such as uncertainty that two people can have different expressions and perceptions of the same stimulus. One example of an implementation using this technique is reported on [14]. A third option is Probabilistic reasoning, as it may

represent a way of analyzing events of user interaction with the software through probabilistic approach relativity. For example, using Hidden Markov Model [16].

5. AFFECTIVE SENSING

Affective computing (AC) is concerned with emotional interactions performed with and through computers. It is defined as “computing that relates to, arises from, or deliberately influences emotions” as initially coined by Professor R. Picard (MIT Media Lab)[18]. AC seeks to facilitate research through the recognition, modelling of human affective states. Practical applications of AC based systems seek to achieve a positive impact on human everyday lives by monitoring, communicating or affecting the emotive states of people. Affective sensing can be considered as being physiological sensors that can be used as part of an intelligent emotional recognition system to elicit an individual’s physiological responses and interpret their emotional states in response to stimuli or task specific interaction physiological sensors for measuring heart rate, temperature and electro dermal activity / Galvanic Skin Response (GSR) have been used to recognize and measure states of stress, arousal and engagement in previous research [19].

Most of the systems currently on the market comprise of obtrusive sensing equipment which are only suitable for laboratory use. There has however been some effort to produce unobtrusive physiological sensor platforms with small form factors which are designed to be used in real world setting for unobtrusive monitoring [20]. Our belief is that these sensors could be integrated as part of the proposed evaluation module. This would enable task specific emotive responses to be captured from patients in context of monitoring their performance on *Mente Activa* simulation exercises. This could help to determine changing levels of engagement or frustration for instance that in context of performance related parameters provide a richer picture of the patients’ cognitive abilities, as any marked changes in their cognition as a consequence of cognitive decline.

6. CONCLUSION

In this paper we report our experience on the design and developing of a game-based stimulation and monitoring system for people with dementia. We considered 7 areas for cognitive stimulation: language, gnosis, executive functions, calculus, attention, memory and orientation. The system was designed specifically for elderly community in Mexico through consultation with psychologists, neuropsychologists, pedagogues, neurologists, graphic designs and software developers. The system was deployed at the Memory Institute which is a unique day therapy centre providing services such as a unique Mental Spa, a Day Therapy Centre, cognitive stimulation programs, and support groups. The system *Mente Activa* will impact positively in the community, retarding the cognitive degenerative process in an easy and engaging way. Our current and future work is to develop and integrate an evaluation module in order to be able to detect abrupt changes on the performance of the user. This could help us to monitor the patients’ cognition, and also the early detection of dementia, in particular Alzheimer.

Acknowledgment

We would like to thank Mrs Ileana Hernández de Sojo, Founder of “Fundación Alzheimer de León” for all the encouragement and support to this project. Additionally we would like to acknowledge the support from CONACyT, DGEST (project 4573.12-P) and INDESOL². Finally, we are very grateful for the kind support from the software development team (Célula de Innovación y Desarrollo de Software) from Instituto Tecnológico de León.

References

- [1] INEGI, “Población Rural y Rural Ampliada en México 2000”, http://www.inegi.org.mx/prod_serv/contenidos/espanol/bvinegi/productos/censos/poblacion/2000/pob_rural/Rural_y_Rural_Ampliada.pdf, pág 69.
- [2] Alzheimer Association, The Global Prevalence Of Dementia: A Systematic Review And Metaanalysis. *Alzheimer's & Dementia: The Journal of the Alzheimer's Association*. Volume 9, Issue 1, Pages 63-75.e2, January 2013.
- [3] Instituto Nacional de Neurología y Neurocirugía, ENFERMEDAD DE ALZHEIMER, 03 de Agosto de 2010 <http://www.innn.salud.gob.mx/interior/atencionapacientes/padecimientos/alzheimer.html>.
- [4] Harry Cayton, Nori Graham, Dr. James Warner. *Dementia: Alzheimer's and Other Dementia* 2nd Edition. Class Publishing Ltd, 2002.
- [5] Linda C. Lu, Juergen H. Bludau M.D. *Alzheimer's Disease*. Editor ABC-CLIO, 2011
- [6] Martha E. Pollack. *Intelligent Technology for an Aging Population*. American Association for Artificial Intelligence. *AI Magazine* Volume 26 Number 2 (2005).
- [7] <http://www.smartbrain.net>
- [8] Liliana Calderón Delgado, “COMPUTER ASSISTED NEUROPSYCHOLOGICAL PRACTICE”. *Revista CES Psicología*, Volumen 2 - Número 1, Enero-Junio 2009
- [9] <https://www.youtube.com/watch?v=usAAPfPc2ao>
- [10] Lumos Labs, <http://i.lumosity.com>
- [11] <http://www.institutodelamemoria.org.mx>
- [12] Shallice T. Specific impairments of planning. *Philos Trans royal Soc Lond* 1982; 298: 199-290
- [13] Dr. Roberto Rodríguez Rey. *FUNCIONES CEREBRALES SUPERIORES*. Cátedra de Neurología, Facultad de Medicina, Universidad Nacional de Tucumán, Republica Argentina
- [14] Faiyaz Doctor, Rahat Iqbal, Raouf N. G. Naguib. A Fuzzy Ambient Intelligent Agents Approach for Monitoring Disease Progression of Dementia Patients. *Biomedical Computing and Engineering Technologies (BIOCORE) Applied Research Group*. Fac. of Engineering & Computing, Coventry University, UK
- [15] F. K. Al-Bin-Ali and N. Davies. Applying Neural and Regression Classifiers for Recognizing Activities in Intelligent Environments. *Intelligent Environments*, 2005. The IEE International Workshop on (Ref. No. 2005/11059)
- [16] James D. Amor and Christopher J. James. Behavioural Pattern Detection from Personalized Ambient Monitoring. 32nd Annual International Conference of the IEEE EMBS. Buenos Aires, Argentina, August 31 - September 4, 2010.
- [17] Department of Economic and Social Affairs Population Division, DESA, *WORLD POPULATION AGEING: 1950-2050*. United Nations, 2002. UNITED NATIONS PUBLICATIONS, ISBN 92-1-051092-5
- [18] R.W. Picard (1997), "Affective Computing," MIT Press, Cambridge, 1997,
- [19] Barreto, A. (2008). Non-intrusive physiological monitoring for affective sensing of computer users. *New Developments*, 85.

² INDESOL has financially supported this project since February 2011 under the scheme of Joint Social Investment Program. INDESOL is a Mexican governmental office commissioned to carry out training, information dissemination, and support initiatives related to social policy and institutional development, coordinating with public and private institutions for the operation and maintenance of projects with high social impact.

- [20] Rosalind W. Picard, "Affective Computing: From Laughter to IEEE," *IEEE Transactions on Affective Computing*, vol. 1, no. 1, pp. 11-17, January-June, 2010
- [21] <http://www.oracle.com/es/technologies/java/features/index.html>
- [22] Pollack, M. E. (2005). Intelligent technology for an aging population: The use of AI to assist elders with cognitive impairment. *AI magazine*, 26(2), 9.
- [23] Ganesan, S., & Anthony, L. (2012, May). Using the kinect to encourage older adults to exercise: a prototype. In *Proceedings of the 2012 ACM annual conference extended abstracts on Human Factors in Computing Systems Extended Abstracts* (pp. 2297-2302). ACM.
- [24] Poh, Ming-Zher, Nicholas C. Swenson, and Rosalind W. Picard. "A wearable sensor for unobtrusive, long-term assessment of electrodermal activity." *Biomedical Engineering, IEEE Transactions on* 57.5 (2010): 1243-1252.

Towards a ground truth dataset for affect detection from physiological information

Patrick MORATORI^{a,1}, Christian WAGNER^a, Robert HOUGHTON^a,
Victoria SHIPP^a, Jaspreet JOHAL^a, Peter WELCH^a, and Shakir ALI^a

^a*Horizon Digital Economy Research, University of Nottingham, UK*

Abstract. In this paper we describe part of our recent work where we aim to create a ground-truth dataset for affective computing to facilitate in particular the application and development of computational intelligence and other automated reasoning techniques. Following a multi-disciplinary approach, we highlight the need for but also the challenge of creating such a dataset that provides validated mappings of physiological data to a series of affective states (“happy”, “neutral” and “sad” in our case). We proceed to discuss the experimental approach and setup employed in this paper where a recall task is combined with a series of groups of pre-rated images which are employed as affective stimuli shown to participants while their physiological data is captured. The physiological data sources captured include galvanic skin responses (*GSR*) and heart rate (*HR*). Preliminary analysis of the results indicates that the statistically the resulting data does not allow the differentiation between the different stimuli/emotions shown/experienced. We provide an initial interpretation of these findings, including a reflection on the complexity of designing “laboratory-style” experiments while still capturing an emotional response from participants.

Keywords. Affective Computing, Physiological Data, Emotions, Ground-truth data set.

Introduction

Detecting affect from a user experience is not a straight-forward task. Questionnaires and self-reports represent relevant sources, but they are likely to be impractical due to their demanding (in particular on participants but also investigators in non-automated settings) and non-real-time nature. A promising alternative is the use of technologies to capture and interpret signals from users’ physiology or appearance (e.g. see [1,2,3]). While some areas of affect recognition such as recognition based on facial features has shown significant advances [4,5], the reliable capture of information on users’ affective state based solely on physiological data such as galvanic skin responses (*GSR*) and heart rate (*HR*) is still a remote goal. The study presented in this paper describes the work being carried out by a multi-disciplinary team at the Horizon Digital Economy Research Institute (University of Nottingham, UK) to investigate the potential of these technologies to detecting user emotions. The main goal is to identify patterns in physiological

¹Corresponding Author: Patrick Moratori, Horizon Digital Economy Research, University of Nottingham Innovation Park, Triumph Road, Nottingham, NG7 2TU, UK; E-mail: Patrick.Moratori@nottingham.ac.uk.

data while users are exposed to controlled stimuli in a laboratory setting and to establish a ground-truth physiological dataset which can provide a starting point for subsequent learning and automatic recognition approaches.

1. Background, Aims and Contribution

Affective Computing (AC) is “computing that relates to, arises from, or deliberately influences emotions” [6], as initially coined by Professor R. Picard (Media Lab, MIT). It has been gaining popularity rapidly in the last decade because of its significant potential in the next generation of human-computer interfaces. One goal of affective computing is to design computer systems that can recognize and respond in a rational and strategic fashion to real-time changes in user affect (e.g., happiness, sadness), cognition (e.g., frustration, boredom) and motivation, as represented by for example speech, facial expressions, physiological signals, and neurocognitive performance. Achieving the aspirations of the very young field of AC is a strongly multidisciplinary challenge with key contributions from Psychology, Human Factors, Computer Science and other disciplines.

Recent years have seen a large expansion in the body of research in and around AC [7,8], in particular from a Computer Science perspective [9], highlighting the need for engagement across disciplines to align emotion theories proposed in the Psychology literature with current modeling techniques in Computer Science. The study discussed in this paper has been launched as a multidisciplinary research project to establish foundations for the investigation of AC, in particular from a computational intelligence point of view. It is driven both by insights from Psychology as well as the potential of modern data aggregation and interpretation techniques from Computer Science. The key challenges across disciplines are:

- Psychology and Human Factors: What is emotion and how can we interpret physiological information in this context?
- Computer Science: How do we automatically recognize “emotions” from multiple uncertain information sources?

This paper discusses the initial experiment design and setup employed to investigate the physiological data captured when showing participants a series of groups of pre-rated images as stimuli. Participant are asked to complete a recall test for each set of images to validate that participants have “actively” viewed the images. Possible relationships between emotional stimuli and physiological responses are investigated, i.e. the affective states “happy”, “neutral” and “sad” are related to the data from galvanic skin response (*GSR*) and heart rate (*HR*). The main contribution of this paper is to showcase and discuss the process of creating a ground truth dataset and to highlight the pitfalls encountered in the work conducted so far.

The remainder of this paper is organised as follows. Section 2 introduces the investigated problem, in which both emotional stimuli and physiological measures are described. Section 3 defines the experimental methodology and presents, analyses and discusses the obtained results. Section 4 concludes the paper and describes future work.

2. Problem Statement and Approach

Ground-truth data is crucial to develop algorithms and tools that enable the automatic recognition and tracking of the affective state of users from physiological data, e.g. to train classifiers. In order to create such data set, a serial recall test is applied, in which pre-rated images from IAPS (International Affective Picture Scale) [10] are used as stimuli to motivate emotional responses from participants. First, a sequence of these images is shown, and subsequently, participants are asked to reproduce the order in which they were shown to them. A set of 24 images was selected for each of the following basic emotions: “happy”, “neutral” and “sad”, in which similar images were chosen for the three groups according to similar ranges for both arousal and valence levels [11,12,13]. As the aim of the work is to provide ground truth, a series of similarly rated images for each emotion was shown in sequence to result in a continuous and sustained affective response from the users. While other approaches, such as the use of videos [14] could be used, the potential for unpredicted/unrated variation of emotional response over the duration of the video motivated the use of series of images. While a sequence of the images is shown to participants, wireless sensors developed by Shimmer Research [15] are used to capture and record both Skin Conductance Activity (*SCA*) and ElectroCardioGram (*ECG*) signals. Both *SCA* and *ECG* have been investigated because they provide involuntary information from participants, which means that natural physiological responses are captured during the emotional stimuli. Further, after each group of images is shown, the participants are asked to perform a recall test in which they see all the images they have just seen on a single screen and are asked to identify the order in which they appeared. The recall task is crucial to ensure that participants actively viewed the images. Other possibilities to ensure this, such as the self-rating of the images seen were considered but the recall test was chosen as the preferable approach with the least downsides (e.g. self-rating of images may lead participants to express what they think that images “should” make them feel, rather than what they actually make them feel). The basic goal is to provide a basic validation of the data captured set by showing correlations between the stimuli shown, the emotional stimuli and the actual data captured from the sensors.

Raw data obtained from both *SCA* and *ECG* require post-processing in which their signals are transformed into more meaningful measures such as *GSR* (Galvanic Skin Response) and *HR* (Heart Rate). Both metrics are described in the following subsections.

2.1. From Skin Conductance Activity (*SCA*) to Galvanic Skin Response (*GSR*)

SCA reflects the ability of the skin to conduct electricity, which may vary as a response to environmental events or the change in psychological state of an individual [16]. It represents a robust and non-invasive physiological measure of the sympathetic activity, providing one of the fastest responding measures of anxiety / stress response [17]. A raw *SCA* signal has to be decomposed into its tonic and phasic components. More details about this decomposition can be found in [18]. The goal is to normalise this signal and, subsequently, detect all relevant responses that occur in an individual after some stimuli. The tonic component is represented by the shaded area on the right side in Figure 1 (a), while the remaining part of the curve has to be flattened to define the phasic part, as illustrated on the left side in Figure 1 (a). Peaks from this curve are then detected, in which relevant ones must commonly have an amplitude greater than 10% of the largest one [19].

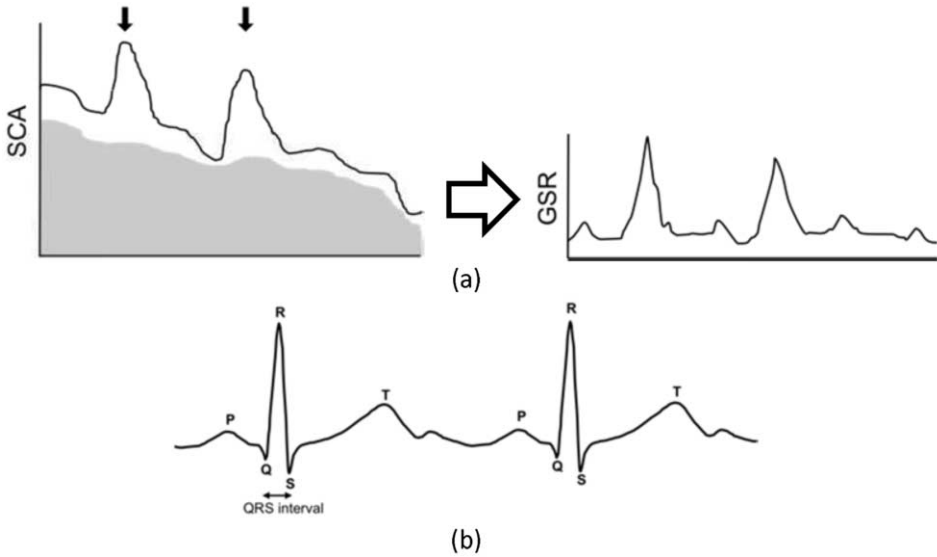

Figure 1. From *SCA* to *GSR* data (a) and a typical *ECG* signal (b)

The obtained number of relevant peaks represent the skin conductance response (*SCR*) measure, also known as galvanic skin response (*GSR*). Note that peaks can be counted based on responses occurring after a given task or as a rate of number of responses per minute. For the example shown in Figure 1 (a), only 2 relevant peaks are detected.

2.2. From *ElectroCardioGram (ECG)* to *Heart Rate (HR)*

ECG is a fundamental data source for patient monitoring and diagnosis [20] from which several features can be extracted, such as heart rate [21], respiration [22]. Further uses for example include the detection of cardiovascular diseases [23]. This paper particularly focuses on measuring heart rate due to its potential on reflecting responses to emotional stimuli [24]. A typical *ECG* signal is composed of several P-QRS-T waves [25], as illustrated in Figure 1 (b). Each peak defined by a QRS interval corresponds to a heartbeat, in which the heart is reaching its maximal contraction to pump blood to the body. The heart rate (*HR*) measures the number of beats that occur per minute, and its typical value is 70-80bpm for a normal, adult human being at resting state [17].

3. Experiment Description

A series of image groups is presented to each participant as stimuli (or indeed as a consecutive stimulus), in which separate blocks of images selected for “happy”(H), “neutral”(N) and “sad”(S) are visualised following a pre-defined order. Each block randomly shows sets of 6 images at a time (from the 24 images previously selected from IAPS based on their valence/arousal scores), and images are shown for 1.25 seconds with an interval of 0.75 second between them. After each block, participants are asked to identify the sequence of the images they have been shown by clicking them (in the order seen) on a summary view with all images. This process is then repeated 20 times for each emotion

category with the aim to induce affective responses in the participants while capturing their physiological response. Physiological data is collected during the emotional stimuli and also when participants are responding to the recall test. Note that results from this recall test are not directly relevant for our study. The test was only applied in order to provide a verifiable metric that participants engaged with the images. A standard serial recall curve was expected and was also found during post-experiment analysis.

Six different orders of emotion categories are defined as a permutation of the three analysed emotions, $Sequence \in \{HNS, HSN, NHS, NSH, SHN, SNH\}$. The aim of the counter-balancing of the order of the image groups shown is both to eliminate the potential for an order effect in the overall results as well as to provide the potential to actually investigate if the order of the sequences is relevant in terms of the affective response. The experiment is done using a purpose-built computer-based application in which physiological data is recorded for each of the 30 participants. This data is then post-processed to extract both *GSR* and *HR* from SCA and ECG, respectively. The results are analysed and presented in the following section. Note that affect-recognition from facial features was also conducted by capturing video information from the participants and analysing it using FaceReader™ by NOLDUS, but this information is not utilised in the current paper.

3.1. Analysis and Results

The results obtained for all emotion categories are summarised in Table 1, which has averages and standard deviation values for both the *GSR* and *HR* measures. In general, standard deviation results for *GSR* achieved quite large values compared to their averages, which highlights the high variability in the obtained data. These results are graphically shown in Figure 2 (a) and (b), in which results for both *GSR* and *HR* are shown for each participant. For the *GSR*, participants 3, 9 and 27 are considered to be outliers because of the exceptionally high variability that is present in their data. The exact reason for this high variation is still being investigated but an issue with the actual sensors and/or their fitting is currently expected to be the source of the problem. The remaining analysis is then conducted with the remaining 27 participants.

An Analysis of Variance (ANOVA) with repeated measures is carried out to investigate the statistical significance of differences perceived in *GSR* and *HR* during the different stimuli. Further, we verify if the order of the emotion categories shown influences the results. Table 2 shows that neither the parameters *Emotion* and *Sequence* lead to a significant differentiability based on the physiological data, since their *P* value are not ≤ 0.05 [26]. These results are graphically illustrated in Figure 2 (c)-(d) and (e)-(f), in which *GSR* and *HR* results are shown for parameters *Emotion* and *Sequence*, respec-

Table 1. Average and standard deviation values for *GSR* and *HR* obtained by stimuli Happy, Neutral and Sad

	<i>GSR</i> - Emotions		
	Happy	Neutral	Sad
Average	35.30	32.60	46.93
Standard Deviation	68.53	58.88	72.13
	<i>HR</i> - Emotions		
	Happy	Neutral	Sad
Average	81.20	81.43	81.70
Standard Deviation	17.15	15.65	15.43

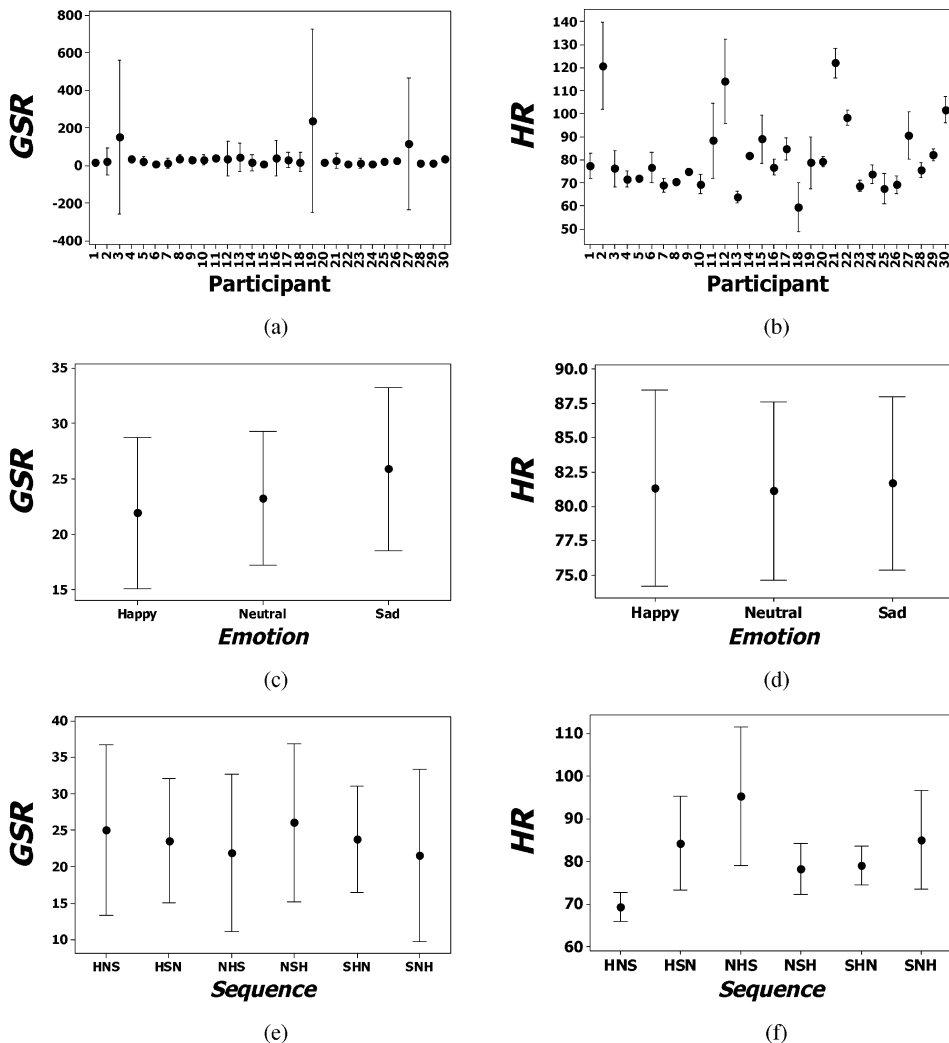

Figure 2. Effects on *GSR* (a)(c)(e) and *HR* (b)(d)(f) due to Participant (a) and (b), *Emotion* (c) and (d), and *Sequence* (e) and (f)

tively. No patterns are observed among analysed samples, apart from the fact that *GSR* results for emotion “sad” achieves a slightly higher values compared to the other emotions. While this is intuitive as “sad” stimuli are known to promote stronger arousal compared to “neutral” or “happy” stimuli, the (statistical) weakness of the result does not allow further interpretation.

From further work conducted since the experiment, we consider the following explanations for the results captured:

- The actual setup of the experiment is the main reason for compromising the obtained results. In other words, the high workload involved in the serial recall test may lead participants to focus their attention on memorising sequences of images instead of being available to emotionally respond to the presented stimuli. While

Table 2. Results of the ANOVA test for *GSR* and *HR*

	<i>GSR</i>		<i>HR</i>	
	<i>F</i> value	<i>P</i> value	<i>F</i> value	<i>P</i> value
Effects				
<i>Emotion</i>	0.44	0.65	0.24	0.79
<i>Sequence</i>	0.13	0.98	1.05	0.10

the recall test played a crucial role in the experiment design, we are currently considering other means (such as eye tracking) to ensure participants engage with the visual stimuli.

- The stimuli were too weak to promote an emotional response. As the images for each emotion category were chosen to have comparable (in terms of their absolute value) valence/arousal values, no “strong” images were selected. We are currently investigating this by employing stronger stimuli.

In summary, the failure to discriminate between the emotional categories based on the physiological data requires further investigation. Current efforts focus both on a re-designed experiment as well as at the utilisation of stronger stimuli (images with higher valence/arousal ratings).

4. Conclusions and Future Work

This paper illustrates some recent efforts to create a ground-truth data set to facilitate the development of computational techniques for the capturing of affective states from physiological data. We discuss the challenge of creating such a dataset in terms of its validity both in relation to pre-rated stimuli and to the reliable detection of corresponding physiological responses. An initial set of experiments and results based on a series of pre-rated images from the IAPS database has been shown, followed by an investigation of the possible relationships between the emotional stimuli and the physiological data captured, i.e. the affective states “happy”, “neutral” and “sad”. In terms of the physiological data, galvanic skin response (*GSR*) and heart rate (*HR*) were considered. Preliminary results indicate that from the current data, the emotional categories cannot be reliably differentiated, thus making it impossible to use the generated data as a ground-truth dataset. Further work is required in order to design experiments that lead to statistically significant differences in the physiological data captured for different emotion categories. Current starting points are the replacement of the recall task in order to reduce workload and to application of stronger stimuli.

Current and future work aims to investigate these options while maintaining a “laboratory style” experiment setting and relying as much as possible on repeatable tasks and pre-rated, well understood stimuli, such as the use of dynamic images and videos [27, 14] and story telling experiences [28]. While very challenging, we believe that the significant potential that ground-truth datasets provide for learning and automated reasoning approaches makes it a challenge worth pursuing.

References

- [1] M. Den Uyl and H. Van Kuilenburg. The facereader: Online facial expression recognition. In *Proceedings of Measuring Behavior*, pages 589–590, Wageningen, The Netherlands, 2008.
- [2] M. Valstar, B. Jiang, M. Mehu, M. Pantic, and K. Scherer. The first facial expression recognition and analysis challenge. In *IEEE Int'l. Conf. Face and Gesture Recognition (FG'11)*, pages 921–926, March 2011.
- [3] M. Valstar, M. Mehu, B. Jiang, M. Pantic, and K. Scherer. Meta-analysis of the first facial expression recognition challenge. *IEEE Transactions on Systems, Man, and Cybernetics-B*, 42(4):966–979, 2012.
- [4] H. Van Kuilenburg, M. Den Uyl, M. Israel, and P. Ivan. Advances in face and gesture analysis. In *Proceedings of Measuring Behavior 2008*, pages 371–372, Maastricht, The Netherlands, August 26–29 2008.
- [5] B. Martinez, M. Valstar, X. Binefa, and M. Pantic. Local evidence aggregation for regression based facial point detection. *Transactions on Pattern Analysis and Machine Intelligence*, 35(5):1149–1163, 2013.
- [6] R. Picard. Affective computing. Technical Report 321, M.I.T Media Laboratory Perceptual Computing, 1995.
- [7] G. Chanel, J. Kierkels, M. Soleymani, and T. Pun. Short-term emotion assessment in a recall paradigm. *International Journal of Human-Computer Studies*, 67(8):607–627, 2009.
- [8] M. Al-Mulla, F. Sepulveda, and M. Colley. A review of non-invasive techniques to detect and predict localised muscle fatigue. *Sensors*, 11:3545–3594, 2011.
- [9] R. Calvo and S. D'Mello. Affect detection: An interdisciplinary review of models, methods, and their applications. *IEEE Transactions on Affective Computing*, 1(1):18–37, 2010.
- [10] P. Lang, M. Bradley, and B. Cuthbert. International affective picture system (iaps): Affective ratings of pictures and instruction manual. Technical Report A8, University of Florida, Gainesville, FL, 2008.
- [11] J. Russell. A circumplex model of affect. *Journal of Personality and Social Psychology*, 39:1161–1178, 1980.
- [12] P. Lang, M. Greenwald, M. Bradley, and A. Hamm. Looking at pictures: Affective, facial, visceral, and behavioral reactions. *Psychophysiology*, 30:261–273, 1993.
- [13] M. Nielen, D. Heslenfeld, K. Heinen, J. Van Strien, M. Witter, C. Jonker, and D. Veltman. Distinct brain systems underlie the processing of valence and arousal of affective pictures. *Brain and Cognition*, 71(3):387–396, 2009.
- [14] J. Arroyo-Palacios and D. Romano. Bio-affective computer interface for game interaction. *International Journal of Gaming and Computer-Mediated Simulations*, 2(4):16–32, 2010.
- [15] A. Burns, E. Doheny, B. Greene, T. Foran, D. Leahy, K. O'Donovan, and M. McGrath. Shimmer: An extensible platform for physiological signal capture. In *Proceedings of the 32nd Annual International Conference of the IEEE Engineering in Medicine and Biology Society*, Buenos Aires, Argentina, August 2010.
- [16] C. Smith. Dimensions of appraisal and physiological response in emotion. *Journal of Personality and Social Psychology*, 56(3):339–353, 1989.
- [17] P. Rani, N. Sarkar, C. Smith, and L. Kirby. Anxiety detecting robotic system-towards implicit human-robot collaboration. *Robotica*, 22:85–95, 2004.
- [18] M. Benedek and C. Kaernbach. A continuous measure of phasic electrodermal activity. *Journal of neuroscience methods*, 190:80–91, 2010.
- [19] K. Kim, S. Bang, and S. Kim. Emotion recognition system using short-term monitoring of physiological signals. *Medical and Biological Engineering and Computing*, 42:419–427, 2004.
- [20] S. Karpagachelvi, M. Arthanari, and M. Sivakumar. Ecg feature extraction techniques - a survey approach. *International Journal of Computer Science and Information Security*, 8(1):76–80, 2010.
- [21] A. Galassi, J. Kaski, F. Crea, G. Pupita, S. Gavrielides, D. Tousoulis, and A. Maseri. Heart rate response during exercise testing and ambulatory ecg monitoring in patients with syndrome x. *American Heart Journal*, 122(2):458–463, 1991.
- [22] S. Ding, X. Zhu, W. Chen, and D. Wei. Derivation of respiratory signal from single-channel ecgs based on source statistics. *International Journal of Bioelectromagnetism*, 6(1):1–7, 2004.
- [23] G. Lanza. The electrocardiogram as a prognostic tool for predicting major cardiac events. *Progress in Cardiovascular Diseases*, 50(2):87–111, 2007.
- [24] S. Poli, M. Sarlo, M. Bortoletto, G. Buodo, and D. Palomba. Stimulus-preceding negativity and heart rate changes in anticipation of affective pictures. *International Journal of Psychophysiology*, 65(1):32–

- 39, 2007.
- [25] M. Kundu, M. Nasipuri, and D. Basu. Knowledge-based ecg interpretation: a critical review. *Pattern Recognition*, 33(3):351–373, 2000.
 - [26] R. Miller. *Simultaneous Statistical Inference*. Springer-Verlag, New York, 1991.
 - [27] M. Soleymani, G. Chanel, J. Kierkels, and T. Pun. Affective characterization of movie scenes based on multimedia content analysis and user’s physiological emotional responses. In *Tenth IEEE International Symposium on Multimedia*, pages 228–235, 2008.
 - [28] V. Bral, V. Maffiolo, I. Kanellos, and T. Moudenc. Towards an expressive typology in storytelling: a perceptive approach. In J. Tao, T. Tan, and R. Picard, editors, *Affective Computing and Intelligent Interaction*, pages 858–865. Springer, 2005.

1st International Workshop on Constructing
[Urban] Intelligence (CUI'13)
This, Here, Now

Dimitris Papanikolaou (Harvard Graduate School of Design, USA)

This page intentionally left blank

Preface

In his book *ME++*, William Mitchell uses Marshall McLuhan's words to describe cities in the 21st century as expanded organisms that use electronic nervous systems to sense the physical world, processors to facilitate decision making, and actuators (crude muscle or machine power) to control flow and availability of resources in real time. Applications include power grids, intelligent transportation systems, water management systems, etc. What is often unclear in such teleological descriptions is how information from the physical world turns into decision and action. Who makes the decisions, who takes the actions, and who evaluates the results? How do the organizational structure and strategic interests of the stakeholders affect the outcome of the feedback loop?

Benefactors and beneficiaries are typically regarded as separate entities with requests flowing from the latter to the former and service flowing the other way around. Today, servers and users may interchange in flat structures such that the same entity may at one time need service from while at another time offer service to its peers. Classic game theory shows that under certain conditions, information and selfish behavior may cause entire ecosystems to collapse suggesting that the problem of constructing intelligence is not always about providing informed access to resources, but often about designing social mechanisms and technologies that will maintain a balanced allocation of resources.

The first workshop on Constructing [Urban] Intelligence (CUI), themed *This, Here, Now*, explores the role of technology, policy, and design in constructing intelligence through agency with a focus on 'on demand' resource allocation. Recognizing that there are multiple ways of organizing tasks, technologies, and strategies to close the loop in human-machine systems, the papers in this workshop's edition discuss provocatively topics such as: how can we rethink human-computer partnership to cooperatively model urban experience? How can crowds of users create micro-ecologies for producing and sharing energy for their own services? How can new participatory platforms improve public and private transit? How is privacy and personal space redefined in networked cities? How do tools for visualizing human mobility patterns enhance our understanding of urbanity?

The CUI 2013 organizers are grateful to the program committee, advisory board, and contributing authors for their effort, insightful comments, and stimulating discussion.

Dimitris Papanikolaou

Chair, CUI 2013

Acknowledgments

Program Chair:

Dimitris Papanikolaou, Harvard GSD

Board of Advisors:

Federico Casalegno, MIT Mobile Experience Lab

Ryan Chin, City Science Program, MIT Media Lab

Antoine Picon, Harvard GSD

Jeffrey Schnapp, Harvard GSD, Berkman Center for Internet & Society

Richard Sennett, Cities Program, London School of Economics

Program Committee:

Ezio Blasetti, Pratt Institute

Daniel Cardoso Llach, Penn State Stuckeman School, Architecture

Lydia Kallipoliti, Cooper Union

Yanni Alexander Loukissas, Harvard GSD

Selene Mota, MIT Media Lab

Nashid Nabian, Harvard GSD

Andrew Payne, Harvard GSD

Orkan Telhan, University of Pennsylvania

Alexandros Tsamis, Universidad Adolfo Ibañez, Chile, Architecture & Planning

Co-Modeling Urban Experience

Hara GAVRA¹

PhD student, School of Architecture National Technical University of Athens, Greece

Abstract. This paper contributes an overview and criticism of Google's newly emerging mass-personalized mapping, as a model of urban intelligence. What is being brought into question is the model's *interactivity*. The analytical tool comprises J.C.R. Licklider's computer-enabled communication model and M. Webber's urban planning model, both from the early 1960's. The overall goal is to re-contextualize the human-computer *partnership* in the direction of *cooperatively shaping* the urban experience.

Keywords. Interactive urban communication, Cooperative modeling

Introduction

Responding to the call for the opening of a discussion around the construction of Urban Intelligence, this paper contributes an overview and criticism of an emerging urban intelligence model through a historical perspective. Google's newly launched dynamic, "fully interactive" and highly personalized mapping is being put under the scope as a medium of constructing a certain kind of urban intelligence. What is mainly being problematized is the alleged "interactivity". To what extent is this computer-enabled urban communication actually *interactive*? Which are the attributed *roles* in the human-computer-urban relationship established by the company? In this newly emerging sense of mass-personalized urbanism, what is the *motivation* that challenges the notions of "community" and "cooperativeness"?

The analytical tool comprises an urban planning model proposed by Melvin Webber and a computer-enabled interactive-communication model envisioned by J.C.R. Licklider. Both models appeared in the early 1960's, in the context of a broadly emerging understanding of the *city as a communication device*. Seen through the lens of this research, their comparative analysis contributes to the problematization of the interactivity in the construction of urban intelligence. The main points extracted are the *motivation* behind the constructed model, the *political* value of information and the importance of "*cooperative modeling*" to interactive communication.

The conclusions drawn on G's "fully interactive", mass-personalized mapping cast some light on the user-computer relationship. Itself interactive up to a certain point, this relationship renders the user/personal-map editor an active participant of G's mapping community. Beyond that -circumscribed by the company- point, the user has no right to access the map. In practical terms, he/she can endlessly edit informing his/her own personal map, but cannot co-write the overall mapping code. Inasmuch as the overall

¹ E: ha.gavra@gmail.com, S: <http://ntua.academia.edu/XaraGavra/Papers>

map is being constantly informed by the users/updated personal maps, the users are *data-providers* and the overall communication is one-way rather than interactive. What reinforces this assumption is the broadcasted mission of the company to organize all of the world's information, as everything that we see in the real world needs to be in their database. By problematizing the issue of interactivity at this emerging case of urban intelligence, this paper re-contextualizes the human-computer partnership in the direction of *co-modeling urban experience*.

1. Mass-Personalized Urban Intelligence

In this part, the newly emerging *urban intelligence* model launched by new Google Maps is being approached. In what ways could it actually be understood as such? What roles does it attribute to each part of the human-computer-urban relationship? Furthermore, to what extent are the users/map editors allowed to edit their own ever-customizable maps? The description of the current model will be developed, beyond mere technical terms, under the scope of the above questions. In parallel, there will be integrated an insightful critique on this map-personalization attempt as that could mean the “end of the public space as we know it”.

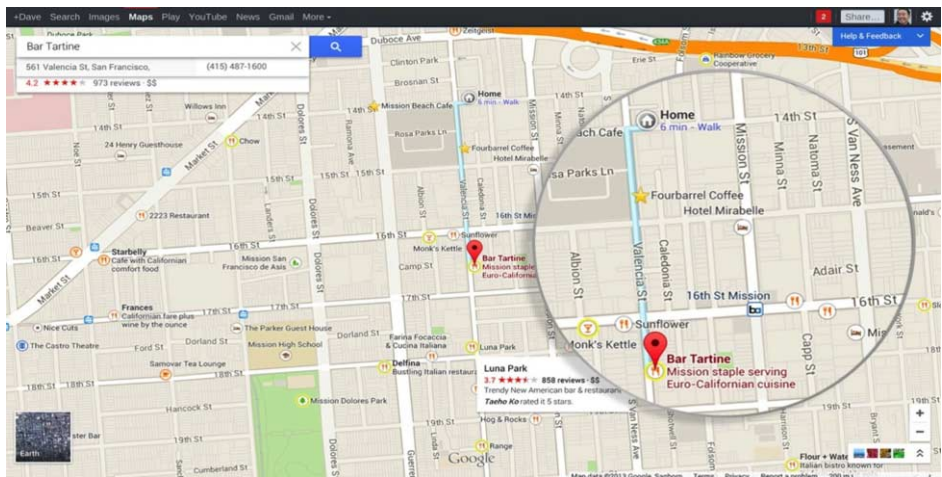

Figure 1. The predicted preference threshold. [Snapshot by Google Maps]

On May 5, 2013 the new Google Maps version is launched by announcement on its blog, while actually inviting interested registered users to request an invitation. Characterized as the biggest change made to the eight-year-old service, this version corresponds to a fully interactive, fully personalized dynamic mapping. Responding to a seemingly *democratic* quest, the company's version enables every user to acquire and edit his/her own unique map that is ever adaptable to each click-choice. “Millions of custom maps, each one just for one's self during his/her lifetime” is the company's promise.

Extracted from the GM's blog, every click –like a friend- draws a map highlighting the things that *matter most*. But, which are the things that do matter most for each and every user? Under which terms things are being included and excluded from the map? Far beyond a philosophical question, the answers are already given in the same text. The more the user interacts with the map, the more accurate it gets. Each user's database is being informed by *recorded* clickable preferences made both by the user and his/her official networking friends. A repertoire of stars, reviews, photos and info cards serves in categorizing the right data for the right user. In addition, after having set the personal home or work location, all possible transportation solutions are also supposed to be available.

Circulating around the above-mentioned questions, the web magazine Future Tense characterizes GM's version as an ingenious move from an advertising perspective. The users are more likely to turn GM into a great data provider for any company interested in advertising itself. Apparently, Google's motivation is far from the mere introduction of radical novelty to citizens' lives. FT states that since advertising is the mainstay of its business, then it needs to convince them of the accuracy and predictability of our preferences. By *artificially limiting* our choices, the article's author claims that us users are actually turned into highly predictable creatures. In brief, "Google prefers a world where we consistently go to three restaurants to a world where our choices are impossible to predict".

Added to the above, another critical point made by the article is GM's implications on our urban experience. Far beyond being technophobic, the author argues that the company's perception of "space" –including G Glasses and self-driving cars – equals to one more type of information. Its stated bold mission of "organizing all of the world's information" and a mapping engineer's comment that "anything that you see in the real world needs to be our database" are quite revealing. Not inaccurately, the author concludes that the company's primary objective is enriching the database, rather than our urban experience.

"Google's Urbanism is ... profoundly utilitarian, even selfish in character, with little concern for how public space is experienced. In G's world, public space is just something that stands between your house and the well-reviewed restaurant that you are dying to go. Since no one formally reviews public space or mentions it in their emails, it might as well disappear from Google's highly personalized maps".

Closing this reference to FT's critique, the introduced GM's mediated urban experience is estimated to conclude to a highly privatized public space. Since each user/inhabitant looks on a different map then there is no common representation of public space for a fertile discourse. Concerned about the future of urbanism, the author clearly opposes the personalization of maps addressed to people "afraid to live in a world they cannot control"-quoting Richard Sennett- while supporting the non-personalized but commonly shared maps. In a sense, it could be argued that the expressed concern is not so much about the actual maps, but about the lack of a *common* ground on which citizens can negotiate their public space. However, this is an intriguing point that will be revisited at the final part of this paper.

2. Constructing Urban Intelligence Critical Tools: the cases of J.C.R. Licklider and M. Webber

The analytical tool comprises two historical models deriving from the urban planning and the computational field, while sharing a common motivation beyond their disciplines' boundaries: *better social communication*. It is actually this motivation that triggers the human-computer-[urban] relationship itself articulated on similar structures. Responding to the communicational shift of their time, both models are structured on overlapping, distributed networks of interactive intelligence centers/common-interest communities. Revisited through the perspective of "interactivity" shaped by the human-computer-urban relationship, these historical references cast some light on the critical points regarding the investigated mass-personalized mapping model.

2.1. *The Roles of Intelligence Centers in Urban Systems Planning: Programm-ing instead of Program-making*

In the Second Annual Conference on Urban Planning Information Systems and Programs (U. of Pittsburgh, 1964), the planning theorist Melvin Webber proposed the concept of distributed, interconnected "intelligence centers". In his keynote *The Roles of Intelligence Systems in Urban-Systems Planning*, he observed the radical changes in the *images* of the cities, with the transition from objects to flows, while at the same time recognizing that these new understandings had not yet been matched by satisfactory urban planning processes".

For a better understanding of Webber's proposal, I will briefly refer to the general climate of that era. Webber was, in fact, both influential and influenced by an emerging orientation towards the displacement of the city by an electronic expansion and the loss of its mere physical limits. This major theme of the 1960s, strongly associated with media theorists like Marshall McLuhan, understood the city as a *communications switchboard*, a computer, or a cybernetic system (Wigley, 2002, p. 106). As Marc Wigley recalls, Richard Meier's 1962 book, *A Communication Theory of Urban Growth*, indicative of the ongoing research, was produced at Berkeley where Webber's influence was highly emerging at that time. A year later, a key essay called "Order in Diversity: Community without Propinquity" is published by Melvin Webber. In that essay the author discusses the city's radical transformation by the emerging communication systems that enable different organizational structures. Beyond the physical boundaries, Webber observed an overlapping system of [social] networks to which each individual participated, thus becoming a member of at least one "non place community". In his next essays, including "The Urban Place and the Nonplace Urban Realm" (1964) and the "Post-City Age" (1968) the concept of the city as a "massive communications switchboard" is fully elaborated. As Wigley interestingly notes, that city's urban quality is to be found in the *diversity of information flow* it facilitates rather than the buildings organization. Within a dispersed sprawl it could arguably be traced a sense of *urbanity*, while physical density is being replaced by communication "intensity". By challenging the established notions of "community" and "centrality", Webber elaborates on a newly emerging social scheme of distributed non-place communities of shared interests. Eventually, the tracing of the *urbanity* within these networks, certainly constitutes a fertile research direction.

Returning to the earlier mentioned keynote, *The Roles of Intelligence Systems in Urban-Systems Planning*, Webber discusses an urban planning model able to correspond to the newly emerging social structures. The proposed model is articulated on distributed networks of open self regulating “intelligence centers” operating with an interim programming strategy. “These centers would serve the multiplicity of groups in the urban areas, supplying improved inventories and forecasts; and they would serve governmental investors by designing targets, programs, and strategies for public action. They would inevitably be engaged in politics and action, but they would bring the scientific morality into urban affairs – a new ingredient in the urban political scene. They are proposed as the effective city planning agencies for this era of flux.”

While recognizing the primitivity of his proposed model, Webber declares that what they can surely supply is *better information* about the current states of affairs in the various urban subsystems. Not inaccurately, it could be assumed that the importance of good information in decision-making processes is the determining motivation for his proposal. Despite the fact that data were “terribly expensive commodities”, Webber transposes the major problem at the selection criteria, and this is a quite interesting part.

Characterizing many data banks of his time as “grab-bag collections of data”, he stresses the importance of a *theoretically based selection*. “Like the drunk who was searching for his lost keys under the lamp post because the light was better there, many of the new data banks seem to be storing data just because these specific numbers happen to be easy to get.” Apparently, what is being negotiated is not exactly the body of data but the *models* according which they will be selected and processed. Clearly stated, in order for the information to be useful, the models of decision-making processes should be informed by urban theory and reciprocally, theory should be informed by the outcomes of this loop. In this context, instead of the strategy of plan-making or program-making, Webber discusses the “tactics of programming” - the installation of urban theory-informed *decision-aiding* processes, rather than a formal program.

In describing the multi-disciplinary ad-hoc groups that form the intelligence centers, Webber focuses the attention at the political value of information, no matter whom it derives from. “Which studies should be conducted? Which models employed? Which data collected? Which analyses made? Which alternatives explored? Which conclusions reported? And which findings and recommendations reported to which of the competing groups? The staff may wish to believe that their science can supply the answers. But, however true that may be, it is equally true that, simultaneously, these would also be political answers of a straightforward sort.”

In this research’s perspective, the political aspect of information and accordingly the non-neutral role of the intelligence centers is *too powerful to be ignored*. Rather, being aware of this impact, it would cast some light to present questions around the data collection and processing, as well as on-line accessibility issues for both the providers and the processors of the information flows. These points alongside Webber’s persistence on the importance of the urban theory-based models will be articulated with key points extracted from the following analytical part, the *human-computer* relationship, as envisioned by J.C.R. Licklider.

2.2. Cooperative modeling equals two-way computer-enabled communication

Around the same time at the other side of the continent, J.C.R. Licklider, one of the *software pioneers*, introduces the concept of *Man-Computer Symbiosis*. Firstly appearing in (1961) *IRE Transactions on Human Factors in Electronics*, the human-computer symbiotic model went far beyond an esoteric hypothesis in a technical journal. It eventually turned into a *national goal* (Rheingold, 1985, p.106). Commenting on the broader context of that time, Rheingold states “when basic science makes breakthroughs at such a pace, and when technological exploitation of those discoveries is so deliberately intensified, a big problem is being able to envision *what’s possible and preferable to do next...* And with Licklider came a new generation of designers and engineers who had their sights on something the pre-Sputnik computer orthodoxy would have dismissed as science fiction”.

J.C.R. Licklider was an experimental *psychologist* at MIT who became the director of the Information Processing Techniques Office of the U.S. Defense Department's Advanced Research Projects Agency (ARPA). Upon joining ARPA in the early 1960s, he started by supporting thirteen different research groups around the United States, while the ultimate goal was “interactive computing”. The exciting concept of *time-sharing* came to be their first step to the threshold of personal computing. The idea, as Rheingold writes, was to create computer systems capable of interacting with many programmers at the same time, instead of forcing them to wait in line with their cards or tapes. Despite the overall program’s military sponsorship, the group, according to the author, was overall aiming to a social and technological transformation. Through his project directors’ achievements in interactive computing, Licklider envisioned a radically emerging computer-enabled communication model.

The *symbiotic* model is a subclass of man-machine systems of that time, inaugurating an essential interactive partnership between its human and electronic members. The roles of each one were defined in the following aims: “1) to let computers facilitate formulative thinking as they now facilitate the solution of formulated problems, and 2) to enable men and computers to cooperate in making decisions and controlling complex situations without inflexible dependence on predetermined programs.” As a subclass of man-machine systems, the symbiotic model seemed to respond to important questions beyond the realms of the human brain or technology. In fact, it was their *relationship* under the scope of better communication that seemed to be Licklider’s persistent question. In this sense, computers acquired the role of “*machines to think with*”.

“The hope is that, in not too many years, human brains and computers will be coupled together very tightly, and that the resulting partnership will think as no human being has ever thought and process data in a way not approached by the information-handling machines we know today”.

A few years later J.C.R. Licklider and Robert W. Taylor predict that in the nearest future “men will be able to communicate more effectively through a machine than face to face.” In their article *The Computer as a Communication Device* (1968) [3], they envision the role of the computer in a creative, interactive communicational model operating through distributed intellectual resources. Regarding the computer-data relationship they state: “Computer programs are very important because they transcend mere “data” – they include procedures and processes for structuring and manipulating data. These are the main resources we can now concentrate and share with the aid of the tools and techniques of computers and communication, but they are only a part of

the whole.... The whole includes raw data, digested data, data about the location of data – and documents – and most especially *models*.”

For Licklider and Taylor, *modeling* is basic and central to communication, as “any communication between people about the same thing is a common revelatory experience about informational models of that thing”. As “*each model is a conceptual structure of abstractions*”, then the major requirement for creative, interactive communication is “cooperative modeling”, meaning cooperation in the construction, maintenance, and use of a model. In these terms, the model acquires the role of a dynamic common medium that can be contributed to and experimented with by all. Such a medium, declare the authors, is the programmed digital computer. “Its presence can change the nature and value of communication even more profoundly than did the printing press and the picture tube, for, as we shall show, a well-programmed computer can provide direct access both to informational resources and to the *processes* for making use of the resources”.

3. Mass Personalized Map-making Vs Cooperative Mapping

With the newly launched interactive, user-customized mapping, it could be supported that G is successfully constructing a certain kind of urban intelligence. Moreover, given the tremendous dissemination expected, then not inaccurately, one could speak of a new sense of urbanism, a *mass personalized* urbanism. Undeniably this kind of mapping establishes a certain human-computer-urban relationship whose direct result is the endless production of maps informed by and customized to the users’ clicked preferences. Reciprocally, urban behaviors are directly and indirectly affected as the map[s] are turning into major referential points when wandering into the urban landscape; an orientation platform so supposedly accurate and real-time mass informed that it couldn’t be but *objective*. So objective that one surpasses its *representational* nature. What is even more, by constantly negotiating the eternal lost & found human uncanny, this kind of over-informing urbanism challenges one’s right to get “lost”. Every possible place-reference, every possible way to get there immediately exhibits itself on the screen; the unlimited freedom to decide among pre-decided options... But, how are these options decided? How are all our clickable data channeled? What *motivates* the decision-making processes? How personal is *my* editable map and to which point am I allowed to access it?

In the historical references, it has been made clear that both Webber’s and Licklider’s motivation was better *social* communication. Even though these past and present models share the polycentric structure of distributed networks, what motivates each established human-computer-urban relationship essentially differentiates them. Far beyond social concerns, the company’s major motivation is more likely to be *marketing-oriented*, as it has been noted in the first part of the paper. In this sense, it could be easily assumed that what plays a key role in the design of data channeling processes is *predictability*. Likewise, the targeted urban behaviors are the predictable ones, while, speaking in social terms, the kind of urban *subject* addressed –if not produced- by G’s strategic is the willingly predictable.

Alongside the overall motivation, another critical point is the non-neutral value of information. As Melvin Webber advocated, the *political*, whether admittedly or not, is equally present to the scientific in each decision level. If one was to examine this in

GM's case, then the already stated marketing-oriented interest is one direction that calls for a future systematic examination. After all, it is a filter that channels the data flows. Of course, not everything is clearly market-driven. Lately broadcasted by Associated Press, "as of May 3, 2013 *Google Maps recognizes Palestine as a country*, instead of redirecting to the Palestinian territories". An unsettling territory of endless violent political negotiations has just been settled in GM's model. For Google this seems to be a simple data shift for its alignment to U.N.'s last year decision about the upgrading of the Palestinian status to "non-member observer state." As it was expected, the Israeli foreign ministry spokesman Y. Palmor stated, "Google is not a diplomatic entity which begs the question why are they getting involved in international politics and on the controversial side". Added from the AP's correspondent, the company has a large research and development center in Israel. Even though the political value of information can be discussed from various perspectives, this particular fact is of a direct political importance. Indeed, it is a clear example –although admittedly unexpected in the beginning of this research- of the non-neutrality of information-processing centers.

A third critical point extracted from the comparative analysis, is the actual modeling "–in and with the aid of the computer". In the case of urban intelligence centers, Webber stresses the pivotal role of urban/social theory-based models at the various decision-making levels. While elaborating on their computer-enabled interactive communication model, Licklider and Taylor highlight the key role of "cooperative modeling", a prerequisite for which is model *externalization*. In the present context of G's dynamic, interactive mapping, could the above points be met?

First of all, as already mentioned, the urban/social theory-driven model is far from G's marketing-oriented one. A rather intriguing point, though, seems to be the cooperation in the "construction, maintenance and use of the model". In GM's case, the maps are editable by "communities" composed of users and developers. In this interactive relationship, the users acquire the role of data providers and map editors. However, if they cooperate in the use and partly the maintenance of this GM's model, they certainly do not *construct* it. When the "Computer as a Communication Device" authors discussed the creative, interactive computer-enabled communication, they specifically stressed the importance of a commonly constructed and accepted model. In order for this to happen, the model should be externalized, in other words *open*.

In the present example, this externalization could be seen as the openness of the map-making code and its free accessibility by the users. This shifted decision would radically change each role in this established human-computer-urban relationship. Indeed, the boundaries between the map-code editors and the users/personal map-editors would blur. In this blurring, the computer would play a key role, becoming a common "machine to think with". In this community context, the "urban" would be produced by a creative, interactive communication between the users/editors, the computer/partner. In practical terms, what is being included and excluded from each map would be decided by the users, rather than by a map-customizing central inaccessible code, itself aligned with marketing trends.

What has just been briefly described, is meant to challenge the decisions made in the modeling structure, rather than proposing an alternative model. In fact, this alternative is already being explored by the open source mapping communities around the world. Probably this should also be taken into account, when Future State's critique rejects GM's tailored mapping and instead, proposes the return to the traditional one-static-map-for all model. It could actually be assumed that the reasons behind this

backward proposal are far from nostalgic or technophobic. What seems to be FT critique's concern is the privatization of what "used to be public space" and the loss of a commonly represented ground to discuss and act upon. What comes as a relief to this concern is the static, manipulable paper map. But, inasmuch as this map is already a ready-made representation, it does not differ from GM's tailored mapping according to representational rules decided by the company. Continuing this thought through this research's perspective, a major concern regarding mass personalized mapping is rather the lack of a *commonly negotiable* public space. In this sense, the concepts of human-computer partnership and cooperative modeling acquire a pivotal role, as they render the urban communication truly creative and interactive.

4. Conclusion

Within the context of urban intelligence, *interactivity* seems to be a multi-semantic word. More than an outcome, it is a relationship shaped by the computer-enabled communication model. Throughout this research, it has been attempted to cast some light on its aspect triggered by the human-computer *partnership*, as envisioned by J.C.R. Licklider. In parallel, M. Webber's urban planning problematic contributed in challenging the relationship between the flows of data and their processing model, in the urban environment. By re-contextualizing these historical perspectives in the case of Google's new mapping experience, this research's aimed contribution towards *co-modeling urban experience* comprises:

- The problematization of "interactivity" in the contemporary construction of urban intelligence
- The designation of the pivotal role of social-driven cooperative modeling in the shaping of the urban experience
- The importance of future systematic research on the human-computer *symbiotic* model towards rendering public space a *commonly negotiable medium*.

References

- [1] M. M. Webber (1965): The Roles of Intelligence Systems in Urban-Systems Planning, *Journal of the American Institute of Planners*, 31:4, 289-296. Also available on line at: <http://dx.doi.org/10.1080/01944366508978182> [Last visit on 17 April 2013]
- [2] J.C.R. Licklider, Man-Computer Symbiosis, *IRE Transactions on Human Factors in Electronics, Vol. HFE-1* (1960), 4-11.
- [3] J.C.R. Licklider and Robert W. Taylor, *The Computer as a Communication Device*, Science and Technology (1968).
- [4] M. Wigley, *Resisting the City, Transurbanism*, V2_Nai Publishers, Rotterdam, 2002.
- [5] H. Rheingold, *Tools for Thought: The History and Future of Mind-Expanding Technology*, MIT Press, Cambridge Massachusetts, 2000. (First published in 1985 by Simon & Schuster/Prentice Hall)
- [6] E. Morozov, *My Map or Yours?*, *Future Tense*. Available online at *Slate Magazine*: http://www.slate.com/articles/technology/future_tense.html [Last visit on May 28, 2013]

End-User no longer

Rethinking the design of distributed infrastructures considering users participation through piezoelectric technology

Elena Vanz^a, Justyna Karakiewicz^a and Amnon Holland^b

^a University of Melbourne, Australia

^b Steensen Varming, Sydney, Australia

Abstract. Infrastructure is a physical device that delivers a service needed to an end-user (consumer). Thus, it is in its identity to be formed by two distinct layers: the physical structure and the carried service. Today transition to decentralized and distributed infrastructures models focuses on redesigning the way of electricity infrastructures operate considering both a local production of the service from renewable resources and technology, and a more proactive role of the end-user.¹ Digital information and communication technology development have increasingly impacted the complexity in which electricity infrastructures operate spatially and temporally through scales, going from local to regional, national and international linkages. However, the restriction in perceiving infrastructures as individual physical objects limits the end-user as intermediary² and neglects the benefit of addressing its active contribution when considering cross-connections between types of infrastructures accordingly to the carried service. Over time infrastructures design has been constrained into a linear model that focuses on optimizing efficiency by increasing capacity in which individual infrastructures types operate. Optimization in distributed infrastructures can be achieved maximizing the way the whole infrastructure performs including the user contribution in defining demand and cross-connections (end-user no longer). Recent technology development in piezoelectricity, has demonstrated that energy can be harvested from the human body and stored in form of electricity. Thus the user can act as well as producer generating electricity through piezoelectric technology used as energy harvesting sensor, and consuming it for its own service(s) such as lighting and communication devices. This model is designed, built and tested in a prototype currently in process to be further explored in a design installation proposed in the City of Melbourne. This work is part of a doctoral research in progress under an ongoing multidisciplinary collaboration involving the fields of architecture, urban design and engineering.

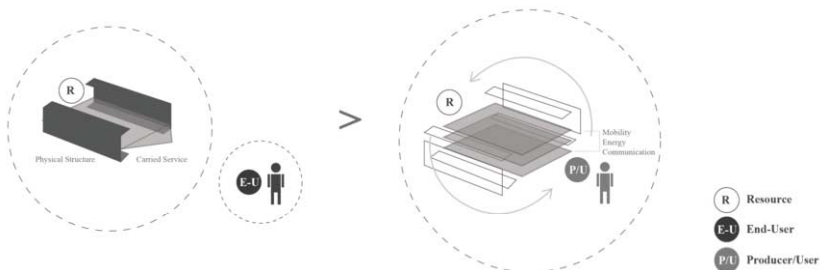

Keywords. End-user, distributed infrastructures, piezoelectric technology

1 International Renewable Energy Agency

2 William J. Mitchell

Introduction

The following paper discusses the first of five research cycles developed adopting an Action Research approach, structured around the integration of architecture, urban design and engineering emerging from cross-connections between electricity, transportation and communication infrastructures. This first research cycle addresses the following question: How can users become producers of their own service through the use of piezoelectric technology? Piezoelectric technology has been used as the potential trigger to rethink the contribution of the end-user within a distributed infrastructure operational mode. Thus the term “end-user” has been challenged to be redundant within a new scenario where a producer of its own service is breaking the linear design of the supply infrastructure chain. This new model is tested in a prototype exploring innovative piezoelectric technology sensors designed and developed for energy harvesting purposes, and the user interface design. It is supported by technical data collection and analysis, design and construction phases, and final findings. The prototype is currently in process to be further developed and tested in a public installation in the City of Melbourne. An overall introduction on piezoelectric technology recent experimentations as energy harvesting sensor unfolds the relevant background research documentation and the need of multidisciplinary collaborations.

1. The Role of the End-User in infrastructures

1.1. Introduction to piezoelectric technology

Piezoelectric technology generates voltage when deformed. By definition piezoelectricity is the electric polarization in a substance resulting from the application of mechanical stress.³ Many researchers have been fascinated by piezoelectric technology mainly in the field of engineering and product design considering a variety of applications.⁴ All piezoelectric devices for applications in the electronics industry require two phases of design: operational principle and optimal operation, and operation device stability against environmental effects, such as temperature changes.⁵ There are over two hundred piezoelectric materials that could be used for energy harvesting energy, with the appropriate ones being selected for each application.⁶ With the beginning of the 21st century piezoelectric technology has developed rapidly opening opportunities for macro scale investigations.⁷ During the last decade academic research has focused on the development of piezoelectricity technology for energy harvesting, potentially be used for lighting and low-powered consuming electronics. Moreover financial investment in research into energy harvesting has expanded dramatically. It is projected that the energy harvesting market will be worth \$4.4 Billion by the end of the decade.⁸

3 Oxford dictionary

4 Raghu Das

5 Jiashi Yang, Editor

6 Raghu Das

7 Harry Zervos

8 Raghu Das

1.2. The beginning of users participation

Until now, piezoelectric technology has gained public attention mainly through novel applications in indoor flooring design such as the Club Watts in Rotterdam, Netherlands, 2008. The aim of this installation is generate electricity from people dancing and using it for lighting the club. The floor exists of a modular system, with components of 65(w) x 65(l) x 30(h) cm, producing up to 25 Watts per module.⁹In this example piezoelectric technology begins to be used a trigger and the end-user actively participate in the supply chain producing the service.

The Club Watt model raises multiple questions related to technical aspects (how the piezoelectric sensors performs), to the design of the system integrating the technology (how the piezoelectric sensors are integrated within the tiles in the dance floor) and the aim of this system related to the amount of the electricity production based on the needed service (lights in the dance room: what type of lights, how many and for how long). The unrealistic expectations in this scenario strictly depend on the “type” of users demand, which is spatially translated considering the function of the room (clubs consume a high amount of electricity). In fact installing the proposed system within an enclosed functional specialized environment not only is limiting in type and number of users through time (by whom, how many and how often that room has been used), but also lack in flexibility that will allow the system to be exposed to multiple scenario, such as type and amount of users and possible contribution considering interconnection between types of infrastructures. Due to the current technological limitation in terms of electric power production, the main focus in a proposed system integrating piezoelectric sensors should move away from considering one specific function (demand) leaning toward taking advantage of the electricity produced to operate interconnectivities between demands of services. If compared the Club Watt with other renewable energy models, initial decentralized solar energy systems integration within urban environments have often failed for a similar cause. In these scenarios the production of the electricity from photovoltaic panels located on a building rooftop were expected to fully support related consumption only considering the building function and neglecting patterns in both power generation (vary daily and seasonally), and type of users demand (services needed). In Club Watt the production of electricity resulted minimal compare to the consumption and now the building is closed. Although this project has become more of a public statement, it initiates users’ awareness on their capability in producing a service and establishes a valuable challenge for further infrastructural models experimentations. In this paper the presented prototype aims to address both technology limitations testing new piezoelectric sensors (hybrids designed for energy harvesting purposes), and to initiate preliminary design investigations related to the integration of the prototype as infrastructure model in urban public spaces in the City of Melbourne, Australia.

⁹ Studio Roosegaarde, Enviu, Architect Firm Döll

2. The Piezo High Striker

2.1. Prototype development process

The development of the prototype started with a preliminary investigation on piezoelectric technology undertaken during the first half of 2012 collecting initial data and testing multiple sensors specifically developed and designed for energy harvesting purposes. The following period of the research focused on the design and construction of a tile integrating piezoelectric technology, including electronic circuit, mechanicals and tectonics, and on testing user parameters such as velocity, frequency and weight. Findings involves the testing of a new hybrid sensor only designed and manufactured at Johnson Matthey Catalysts called V2 type, as well as user-technology interface data analysis, including the user production and consumption of the service. The prototype was built in collaboration with industry partners Steensen Varming and Arup Engineering, and it has been displayed as part of *Re-Powering Sydney* Master Design Studio exhibition at Customs House, in collaboration with City of Sydney and University of Technology, Sydney.

2.2. Design concept

The Piezo High Striker is a proposed prototype that addresses the following idea: How fast can you turn the light on? Have fun and bit your partner. The aim of this prototype is to evaluate the energy users expend when on the move to augment low powered electronic devices and lights. The Piezo High Stiker is a game where two users compete in electricity generation. Piezoelectric technology is integrated into a tile and generates electricity when users jump on it. In the original proposed model, the piezoelectric elements were to be utilized to charge a storage circuit (via a capacitor) and then use this stored power to light a LED display. The resulted voltage is monitored and displayed on a bar graph and read by the user. When the bar graph reaches full capacity, the stored charge powers LED lights located next to the tile. However due to experimental complications with the piezoelectric generator output (explained below) the bar graph was powered by a plug pack, and smaller capacitor was charged, which at a certain trigger voltage switched on a LED lights. Due to the low amount of energy harvested it is premature at this stage to consider an additional storage device to allow further control of the use of the power generated (eg. 24 hours storage).

2.3. Piezoelectric technology selection and testing

This preliminary investigation helped establishing a contact with Johnson Matthey Catalysts (formerly SIEMENS AG) in order to begin technical data collection and evaluating piezoelectric products performances as energy harvesters. This German company founded in 1817 and specialist for catalysis, precious metals, fine chemicals process technology and piezoceramic products and systems. Johnson Matthey Catalysts has been chosen as has leading global market positions in all its major businesses. Out of a broader selection of piezoelectric materials two were assessed following characteristic values such as electrical, electromechanical and mechanical data, thermal

behavior and thermal data.¹⁰ The dimensional scale of the piezoelectric materials chosen considered that there is high efficiency in smaller elements. This given role is based on: the uniform deformation the higher deformation, and no flow of charge to less deformed areas onto the metalized surface and therefore avoidance of deformation of the piezoelectric ceramic at such areas.¹¹ In terms of stress and strain, because of an asymmetric geometry it is possible to create the piezoelectric part in that way that the ceramic is only stressed. This is the principle to achieve a long lifetime.

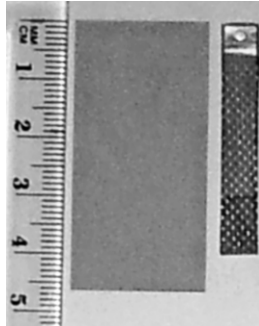

Figure 1. Piezoelectric elements tested: piezoceramic and V2 type

Two different types of piezoelectric sensors were assessed (Figure 1). One type was a single slab of piezoceramic material, which appeared much like standard sensor, or audio transducer type material in nature. The available voltage from this device could reach approximately 2 volts peak, but the stresses required to produce such voltage levels were near the breaking point of the element. The second piezoelectric generating sensor was a hybrid material only manufactured at Johnson Matthey Catalysts, Germany, called V2 Type, and more specifically designed as energy harvesting sensor. The overall element was flexible, and seems to be comprised of piezoelectric material embedded in a flexible composite. This device could produce outputs of several volts or more in response to moderate physical shock, and was highly resistant to breakage. Due to timing and logistical impediments the following prototype testes electronic circuit configuration and mechanical arrangement considering piezoelectric ceramic sensors (first type tested). However, parallel tests and analysis on power output considering V2 type establish the platform for the following prototype development.

2.4. Electrical circuit configuration to minimize diode losses and power collection efficiency

The presented circuit (Figure 2) is one of the cheaper and more efficient usages of the piezoelectric power as there is no voltage conversion needed (those circuits have inherent efficiency losses). The piezoelectric sensors output is AC in response to the

¹⁰ Johnson Matthey Catalysts, Germany

¹¹ Johnson Matthey Catalysts, Germany

applied pressure, and a voltage doubler configuration is used to minimize diode losses per element. The size of the capacitor used determines how long it will take to reach the trigger voltage and also determines the time the lights stay on. Each piezoelectric element generally output between $\pm 2\text{v}$ AC (with associated current less than a few mA) when pressures in excess of $1\text{kg}/\text{cm}^2$ are applied, which presents problems due to the low energy output.

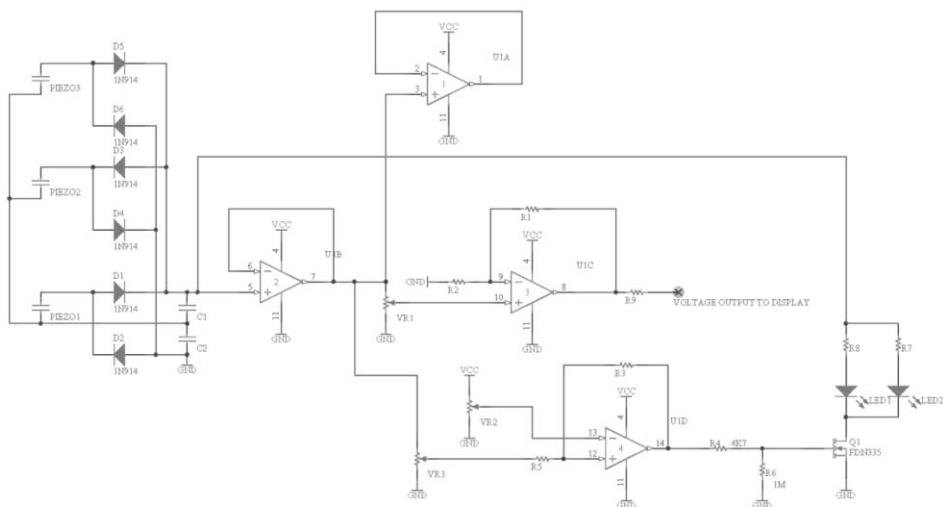

Figure 2. Electric circuit diagram for the piezoelectric tile prototype, June 2012

Due to the complex physics and mathematics involved with calculating output voltage and currents associated with deformation of the piezoelectric crystal, practical methods tend to be a much better solution to gauge output. The output voltage and current depend on many parameters including rate of change of applied pressure, non-uniformity of loading, temperature and load resistance, thus no firm parameters can be given. At short circuit conditions output current will be a few mA at maximum which depends on the volume of the sensor as well. Although this suggests the output power order of magnitude is likely to be in the mill watt range it is noted that photovoltaic systems use a similar principle with the utilization of a large amount of 'cells'. Moreover, with advances in power electronics it is envisaged that the collection efficiency of these kinds of circuits will increase. It is noted that typical collection efficiencies in the range of 30 to 60% are currently achievable with such circuits as used in this experiment. However the main complication in energy harvesting from piezoelectric sensors is due to the voltage discrepancy between elements, which could lead to back feed of power into parallel units when different pressures and rate of pressure is applied to different elements. Potential solutions to element power mismatch are a more discrete electronic collection circuits, a use of maximum power point tracking circuits, a careful disposition (design) of piezoelectric elements, a use of inline and bypassing diodes and then ultimately the mechanical configuration of these elements for even pressure distribution across the same electrically connected 'string'.

2.5. Mechanical arrangement for uniform loadings

The second challenge with the piezoelectric energy distribution in the tile is the mechanical arrangement, so that equal pressures and rate of pressure changes are applied to the elements in order to reduce fracture or damage of the units. Since two electrical connections must be made to the element, the challenge is that when pressure is applied to the crystal, it does not crack (due to point loading i.e. from a soldered wire). Thus it is proposed that the best solution may be conductive tape since an even thickness can be applied to the front and back of the crystal for current collection, however tape resistances must be considered. To address mismatch limitation solutions are proposed considering a reduced number in parallel per “collection circuit”, a usage of rigid materials for the tile together with the optimization of the geometrical arrangement of the sensors to uniformly distribute the pressure, and an improvement in matching of sensors "electrical characteristics" from the manufacturer via automated sorting systems (eg. the one used in the solar industry for sorting and grouping photovoltaic cells with similar IV curves).

2.6. User-piezoelectric technology interface

In designing and building the structure, one footstep per tile was considered as primary parameter defining the user-technology interface design. The selection of the material considered physical characteristics such as thickness based on footstep pressure and scratch resistant, slip and waterproof resistant, costs and maintenance. A 1.3 cm acrylic stratum was used as material for covering electronics and mechanical arrangements of the system below integrated. Transparency was also a selected material property as reinforcing the participation of the user in visualizing how the whole system operates. The base of the tile was made with a solid wood slab linked to the acrylic sheet by steel L-shaped angles. Holes along the angles allowed wires to connect the tile to the bar graph and display (Figure 3).

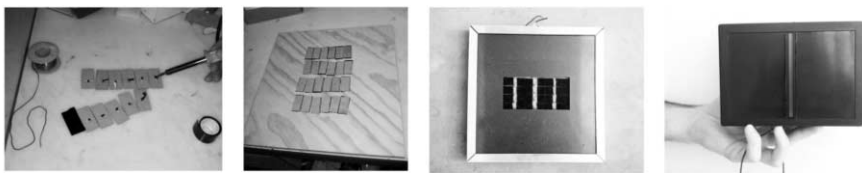

Figure 3. Tile prototype

The integration of the piezoelectric sensors within the structure aim to be electrically and geometrically optimized, thus once users step on it, point loadings generate voltage and current that the collection circuit is consequently stored. The capacitor keeps charging similar to a battery until it reaches a voltage threshold, which is enough for the electricity in the capacitor to be used to power LED lights.

3. Conclusions

Considering the initial question *how can users become producers of their own service through the use of piezoelectric technology?* this prototype validate the feasibility of it considering LED lighting output. However the implementation of piezoelectric sensors at urban scale is still questionable due to the low amount of energy harvested, calling for further experimentations especially considering additional storage devices. The presented investigation substantiated the great potential in testing new hybrid types of piezoelectric sensors such as V2 type, recently designed specifically for energy harvesting purposes. The ongoing R&D conducted on V2 and other types, such as the Bending Actuator Type, establishes continuous new opportunities for sensors testing and selection. Moreover, considering that not only volume is the parameter that can be controlled, but also placement and number of the sensors, the research further explores the possibility of increasing power generation testing the correlation between specific sensors arrangements, electronics, mechanical mounting, construction materials and pressure applied (investigated in the following research cycle). Additionally, the presented prototype has challenged the innovative concept of using sensors electrical signals for pedestrians counting. A preliminary design tested its integration in step nosing profiles considering LEDs and signal outputs as a method for lighting and communicating pedestrians' numbers and position in selected crowded urban locations in Melbourne Central Business District. When considering existing urban sites, piezoelectric sensors can be retrofitted addressing the benefits of a minimum amount of space required and compact construction, silent operation, self-sufficient and reliable (does not depend on external power sources), high resistance to humidity and none maintenance costs (15 to 20 years life-time). It is additionally envisaged that the use of piezoelectric sensors as energy harvester can be viable if the cost of the technology significantly dropped, open up opportunities for feasibility studies into the potential for mass scale utilization.

4. Following experimentations in urban design (in progress)

The next investigation currently in process represents the second of the five research cycles that aims to be completed by August 2013. This second cycle is addressing the development of the prototype discussed in this paper eventually becoming public installation to be built in the City of Melbourne. In this cycle the proposed distributed infrastructure model introduces pedestrians as users and producers of their own collective service(s) considering cross-connection between electricity, communication and transportation, and challenging viable large-scale network implementation in urban areas. As previously established, in order to use piezoelectric sensors as main energy harvesters, additional experimentations are necessary in order to maximize the electricity generation, minimizing unnecessary power losses and providing efficient storage devices. Moreover, the opportunity of combining piezoelectric sensors with other innovative technologies used as well for energy harvesting has been evaluated in order to combine complementary capabilities.

Following Melbourne City Council guidelines, the installation aim to be functional and accessible, for users affected by low vision and visual impairment as well as exciting and sustainable, challenging an innovative identity for pedestrians. The

preliminary installation design aims to provide the link between technology application and user interface. It combines more permanent structures, defined through the integrated technologies on site, and temporary display designed considering tool-free assembling and selected lighting effect. Each of these parts interconnects and supports the installation operational system. Moreover, the integration of multiple technologies uncovers further experimentations and innovation in testing piezoelectric sensors as part of a broader system.

5. The relevance of multidisciplinary collaboration

Defining, researching and developing infrastructures models emphasize the importance and challenge of a multidisciplinary work involving the fields of architecture, urban design, and electric, mechanical and structural engineering. It brings together faculty and researchers from School of Design, Architecture, Building and Planning, School of Electric and Electronic Engineering, School of Infrastructure Engineering and School of Mechanical Engineering at University of Melbourne, Australia. Ongoing scheduled meetings become essential for the development of the research work considering both theoretical and pragmatic implications, although also disclose major challenges related to correlation between multiple experts and research outputs.

This work also involves local industry partners such as ARUP Engineer offering lighting design expertise, and Melbourne City Council willing to support the possible public installation. The international industry partner Johnson Matthey Catalysts (formerly SIEMENS AG), a German piezoelectric products manufacture, has been approached to provide the piezoelectric technology and more specific technical expertise. An additional collaboration with Samsung Group is in process to be established, including a fieldwork in Seoul, Korea. Samsung Group will bring the unique expertise of integrating piezoelectric technology into low powered electronic devices collaborating with local piezoelectric technology industries and testing different type of piezoelectric elements. This overall multidisciplinary cooperation is essential to fully explore potentials in designing the proposed distributed infrastructure model. It emphasizes once more the benefits of linking academic research projects and professional work focusing on the same agenda.

References

- [1] International Renewable Energy Agency, *www.irena.org*
- [2] William Mitchell, *Intelligent Cities, e-journal on the knowledge society* (2007), Iss 5.
- [3] Carl Martland, *Toward More Sustainable Infrastructure*, John Wiley & Sons, Cambridge (2012)
- [4] Raghu Das, Piezoelectric energy harvesting market to reach \$145 million in 2018, *Energy Harvesting Journal*, IDTechEx (20 August 2012)
- [5] International Renewable Energy Agency, *www.irena.org*
- [6] William Mitchell, *Intelligent Cities, e-journal on the knowledge society* (2007), Iss 5.
- [7] Oxford dictionary, *oxforddictionaries.com*
- [8] Jiashi Yang Editor, *Special topics in the theory of piezoelectricity*, Springer, New York (2009)
- [9] Raghu Das, Piezoelectric energy harvesting market to reach \$145 million in 2018, *Energy Harvesting Journal*, IDTechEx (20 August 2012)

- [10] Harry Zervos, Piezoelectric energy harvesting: developments, challenges, future, *Energy Harvester Journal*, IDTechEx (10 January 2013)
- [11] Raghu Das, Piezoelectric energy harvesting market to reach \$145 million in 2018, *Energy Harvesting Journal*, IDTechEx (20 August 2012)
- [12] Studio Roosegaarde, Enviu, Architect Firm Döll, *Sustainable Dance Club (SDC)*, Rotterdam (2008)
- [13] Johnson Matthey Catalysts, *piezoelectric products data sheet* (2012)
- [14] Johnson Matthey Catalysts, *confidential documentation* (2012)

Integrating game elements for increasing engagement and enhancing User Experience in a smart city context¹

Katerina DIAMANTAKI^a, Charalampos RIZOPOULOS^a, Vasileios TSETOS^b,
Iouliani THEONA^c, Dimitris CHARITOS^{a,2}, Nikos KAIMAKAMIS^a

^a*Faculty of Communication and Media Studies, National and Kapodistrian university
of Athens, Athens, Greece*

^b*Mobics Ltd., Athens, Greece*

^c*School of Architecture, National Technical University of Athens, Greece*

Abstract. This paper outlines an ongoing project (MITOS), which aims to customize and deploy a software platform providing advanced transportation services in the city of Santander, Spain. The system will be presented with a focus on the design framework and the rationale for evaluating User Experience in such a framework. Concepts for Future Internet environments, such as participatory sensing, game-inspired practices, and ad hoc social networks, will be employed toward this purpose. A set of experiments will be conducted, aiming to qualitatively and quantitatively evaluate the deployed system and assess the impact that its services have on the city, on its citizens / commuters, and on their attitudes towards public transportation use. The project is expected to provide methodological insights on the design and evaluation of interactive location-based systems in hybrid urban contexts. The impact of the system will be manifold and fully aligned to all dimensions related to the impact of the SmartSantander project: environmental, transportation, societal and research / technological. The deployed platform will be available to the city for further experimentation and commercial exploitation, thus being a sustainable system that can affect the activities of the citizens even after the end of the SmartSantander project.

Keywords. Smart cities, environmental sensing, location-based services, game-like urban activities

Introduction

ICTs are today being recognized as one of the most important factors towards the creation of smart, sustainable cities with high-quality living, and have been applied in areas as diverse as education, crime prevention, energy-saving and public transport. In the area of urban mobility in particular, the utilization of mobile and location-based technologies is considered to be one of the most efficient ways of enhancing a city's

¹ This paper describes work undertaken in the context of the SmartSantander project, partially funded by the European Commission under contract number ICT-2009-257992 (FP7)

² Corresponding Author: vedesign@otenet.gr

smart transport infrastructure, on account of the prevalence of GPS-and Internet-enabled smartphones. Citizens equipped with smartphones can act as nodes in a network of sensors which provides data related to the city's transportation services. Additionally, dedicated sensors may be employed in order to provide data such as position of vehicles, availability of parking space, traffic density, atmospheric conditions, etc. We are, therefore, talking about a hybrid sensor ecosystem, in the sense that it combines both human and non-human agents as two distinct yet interrelated sources of city-related data.

This paper outlines a research project, funded under the FP7 framework, which aims to enhance the User Experience of an advanced transportation services platform through *gamification*, i.e. by incorporating simple game elements and mechanics within the very design of the platform [26-27]. This decision was based on the hypothesis that a non-game platform that provides affordances for gameful experiences will support users' overall engagement and value creation. As has been frequently reiterated in the last years, gamified designs encourage technology adoption, motivate user behavior and enhance user satisfaction [28-29]. This is because game-like activities and ludic interfaces tend to make technology more engaging, by encouraging users to adopt desired behaviors, by taking advantage of humans' psychological predisposition to engage in game and by leveraging people's natural desires for competition, achievement, self-expression and enjoyment [30-32]. In the application described in this paper, gamification is employed primarily for motivating the users to use the application, but also as a means of increasing randomness and even providing a convenient entry point for possible future additions, e.g. a narrative structure³.

More specifically, the project's goal is to motivate citizens to commute more by using public transport and to participate in the collection of related data (traffic, incidents, environmental conditions) by utilizing the aforementioned technologies, as well as to enrich the system with subjectively meaningful location-specific content. By providing the system with information about the transportation conditions in certain locations, citizens may feel they get involved in a common goal. By enriching specific locations with meaningful comments, various forms of social interaction amongst some of these citizens may emerge, ultimately leading to an improvement of the social use and appropriation of these technologies and the appearance of novel forms of social behavior which are worth investigating in a systematic and rigorous fashion. The ultimate aim of the project is to foster bottom-up community intelligence and active citizen participation in urban matters.

1. Overview of the *SmartSantander* project and the MITOS experiment

The main goal of the MITOS (Multi-Input TranspOrt planning System) research project is the creation of a European experimental test facility for the research and experimentation of architectures, key enabling technologies, services and applications for the Internet of Things (IoT) in the context of the smart city⁴. The project work team has designed, implemented and deployed all required infrastructure for enabling smart

³ On a methodological side note, it is important to note that gamification may alter the activity it is applied onto from the user's perspective; a "gamified" application has incorporated game elements into its structure, and these elements may need to be taken into account when evaluating non-game-related aspects of the application. In other words, the practice of gamification may assume the status of the "third variable".

⁴ www.smartsantander.eu

city services in the city of Santander and some other facilities across Europe. The project considers the deployment of sensors in Belgrade, Guildford, Lübeck and Santander. The middleware services developed provide all functionality required so that experimenters can deploy their services or algorithms and draw interesting conclusions regarding smart city services, IoT features etc.

As part of this project, an experiment for Intelligent Transportation Services in the context of the Smart City will be designed and performed. The services and applications deployed and demonstrated in the context of MITOS will be:

- A Web portal for transportation information that will be essentially used as a city guide for citizens or tourists. The core functionality provided by the portal will be:
 - o Location-based services such as traffic heat-maps, geocoding, visualization of points of interest (POIs), search for transportation information, incident notification, location-aware advertising, parking availability, real-time pollution and temperature information, etc.
 - o Optimal-routing for multi-modal transportation. Route planning will rely on dynamic data (either collected from sensors or generated by users).
- A mobile application for advanced transportation services. The application will provide all type of information required by commuters and will enable intuitive ways for searching routes and geo-referenced information based on the personal preferences or abilities of the user. Moreover, it will be used for participatory sensing purposes, complementarily to the existing participatory sensing application.

The MITOS platform will exploit existing sensor sources in order to deliver advanced services to the end users. These sources are:

- A participatory sensing application: users will act as sensors that provide relevant traffic and travel information in the form of free text or predefined messages (e.g. “heavy traffic”, “too much noise”, etc.) and/or image⁵. This strategy is expected to reduce the total amount of messages requiring moderation, thereby reducing the moderator’s workload. They will be able to report incidents and traffic congestion. In this sense, the act of gathering data on the city’s everyday functioning becomes a more decentralized process.
- Environmental data: data stemming from environmental sensors deployed in the smart city (noise, temperature, CO/ CO₂ emissions) will be used in order to evaluate the environmental improvements resulting from the increased use of public transportation as well as current environmental conditions in the city.
- On-street parking space availability. The existing street sensors will be used in order to assist commuters in their trip planning and facilitate combined mobility modes (e.g., car and bus) by offering information on parking availability.
- Traffic intensity estimation. The existing traffic data will be fed into the platform in order to enable better and more accurate transportation guidance to citizens.

⁵ This strategy is expected to reduce the total amount of messages requiring moderation, thereby reducing the moderator’s workload.

- On-vehicle devices (GPS) will be also interfaced to the platform in order to provide accurate arrival and inter-arrival times of public transport.

Several algorithmic issues are considered during the setup of the experimental platform. For example optimized routing and trip-time estimation algorithms are involved which have been already applied to other cases [24]. Moreover, the system will be able to take into account user preferences or limitations in order to deliver personalized route selection.

2. Application functionality

The main concept behind the MITOS project, in order to provide advanced transportation services, is not only to deploy data derived from the existing sensor and middleware infrastructure available in Santander, but also to engage citizens in participatory sensing practices. This methodology is considered to contribute to the accuracy and the quality of the services offered by the system, as it provides commuters with accurate information about incidents and issues pertinent to the transportation, as well as to the environmental conditions of the city. As a means of making the system more appealing and fun to use, the central design principle of MITOS is to incorporate game-like features in certain aspects of everyday transportation and at the same time support the emergence of ad hoc social networks.

The MITOS project features a game-like activity taking place in real time throughout the city of Santander. The game is persistent; it is always going on, and users can participate whenever they wish. The MITOS system, largely making use of an existing software platform developed by Mobics in Athens, Greece, is designed to encourage gameplay while on the move, so that commuters can easily participate. Therefore, two types of users may be distinguished in the MITOS system: *mobile* and *desktop*. The former use an application on their mobile phones, whereas the latter connect via a desktop computer. A map displays all active mobile users as they move around in the city. Desktop users have access to the whole city map, where the positions of all active users are updated in real time. Desktop users can see events recorded in the entire city area, while mobile users can see a limited number of users and events based on proximity. Users may alternate between desktop and mobile mode.

MITOS utilizes an achievement and task-reward system as a means of encouraging the use of the application. The basic goal of the game is to gather as many points as possible. Points will be translatable to several kinds of tangible rewards, such as free bus tickets or special offers by affiliated shops. Each action in the context of the game corresponds to a specific point value. Thus the possibility of collecting points acts as an incentive for increased usage duration and frequency. Though players do not directly compete against each other, a number of high-scoring players will be rewarded on a daily basis; an optimal number of rewarded players will be sought, so that being rewarded is neither a remote possibility (when only one user is rewarded) nor a certainty (when the reward criteria are too lax, leading to practically everybody winning). Similarly, the most active user of MITOS system during the course of one week will be nominated for a reward of greater value. However, this is a game with no winners and losers in the traditional sense; participation increases the possibility of gaining points, which increases the amount of benefits attained, and even the users who are last in the

standings will have won at least some points – assuming they performed at least one game-relevant action.

In general, players are encouraged to use the public means of transportation and plan their itinerary consulting the MITOS system maps. The maps offer multimodal routing and additionally integrate data provided by a network of sensors, as well as messages posted by users on the platform and relevant geolocated content. MITOS' deployed sensors give information about temperature, CO₂ levels, humidity, noise, number of available parking spaces, etc. Users can access the maps beforehand, while on desktop mode, so as to have a general idea of the traffic situation in the whole city and accordingly decide on the best route; alternatively, they can have a focused view of the surrounding area via the mobile app while on the move.

The main form of communication provided by the MITOS system is text-based. A number of predefined text messages (e.g. “heavy traffic”, “accident” etc.) are available, in order to expedite the process of reporting traffic-related issues. Alternatively, users may compose their own message (up to 140 characters). Employing the aforementioned tools, participants can report incidents they witness while on the move. Additionally, mobile users can act as “environmental sensors” by providing coarse-grained environmental data (e.g. perceived temperature or sound levels), thus supplementing the detailed information attained by sensing devices located in various parts of the city. They may also take pictures or record video and tag it on specific locations. Participants earn points for each of these actions. Desktop users can also contribute to the exchange of messages, gaining points as well. In such a way, indirect and asynchronous communication among the two functionalities is sustained through the MITOS system.

3. Evaluation

3.1. Objectives: Operationalizing User Experience

The deployed system will be evaluated against both objective and subjective criteria. The former pertain to technical and system-related parameters, whereas the latter are focused on the users' underlying psychological and cognitive processes during system use. The subjective aspect of the evaluation revolves around the concept of User Experience (UX), widely recognized today as one of the most important success factors in developing interactive applications.

Following Hassenzahl & Tractinsky [13], we take UX to be a dynamic process influenced by a variety of factors that can be grouped into three main categories: “user's state and previous experience”, “system properties”, and the “usage context”. Taking *user state and previous experience* to be one of the determining factors influencing UX means considering variables such as a person's previous engagements with technology, motives for using the product, current mental and physical resources, as well as expectations about the system before its actual adoption. A user's experience is also influenced by the *properties of the deployed system* and the user's perceptions of them. “Properties” in this context refers to properties designed into the studied system (e.g. functionality, responsiveness, aesthetics, designed interactive behavior), the properties that the user has added or changed in the system or that are consequential of its use (e.g. content uploaded by the user), as well as the brand or manufacturer image (e.g. sustainability, coolness). Thirdly, the overall UX from interacting with a system is

largely determined by the *context in which it is being used*. UX is context-dependent, meaning that it may change when the context changes, even if the system does not change – thus using an intelligent transport platform in a bus packed with people may be different than using it before entering one’s car to drive into the city. The social context also matters, since usage will not only be influenced by what the user is doing but also by who else is present and what their relations are. Overall, context in the UX domain refers to a mix of social context (e.g. being with other people), physical context (e.g. using a product on a desk vs. in a bus on a bumpy road), task context (the surrounding tasks that also require attention), and technical and information context (e.g. connection to network services, other products).

User experience is also fundamentally recognized as being *subjective* in nature and related to an individual’s perception and thought with respect to a system. It is also broadly understood as being broader than *satisfaction*, (itself considered one of the aspects of usability [15]), in the sense that it covers more intricate, even latent, symbolic, epistemic, and affective dimensions that cannot be reduced to a mere usability and satisfaction analysis.

Based on these assumptions and the extant literature on the topic [2-7, 12-13, 16-18, 21-23], we have arrived at a number of tentative UX meta-dimensions that serve as the building blocks of the ongoing MITOS research project. More specifically, UX from the MITOS system usage will be evaluated in terms of the following dimensions, each to be analyzed in terms of its components:

- *Functionality and utility*: the usefulness of the system to the users’ customary everyday activity.
- *Usability and performance*: the system’s objectively (e.g. metrics such as error rate, time to complete tasks etc.) and subjectively (e.g. self-report via questionnaires) assessed ease of use. Cognitive aspects, i.e. the efficiency of the system in terms of cognitive requirements (e.g. attention, memory), are also included in this dimension. Relevant variables include task-goal achievement, efficiency, effectiveness, learnability, understandability, memorability, etc.
- *Emotional impact*: subjective, affect-based evaluation of the system’s use (commonly referred to as “user satisfaction”), encompassing perceptions about the product itself and the quality of experience derived from using it. Variables typically associated with this dimension include pleasantness, enjoyment, confidence, trust, intention to use, restriction, liberation, stimulation, identification, evocation, expressiveness, novelty, connectivity, competence

3.2. Research Questions

The specific research questions that underline the focus of the research project are aligned with the basic tenets of our holistic operational definition of UX that encompasses contextual, social dynamic and affective aspects, besides the most pragmatic and functional attributes that are being measured in most usability studies (e.g. [19]). The first set of questions aims to identify the key elements of the overall user experience with the MITOS System, and includes questions such as:

- What are the key elements of the overall User Experience with the MITOS system and how does it compare with users' pre-usage expectations?
- What are the primary influences and determinants of user adoption of the system?
- How do different game elements affect the user experience?
- What benefits and what functional shortcomings do users see in the system?
- To what extent are users able to achieve their goals with effectiveness and efficiency?
- Which factors seem to affect the usability of the system, either positively or negatively?

The second set of questions goes beyond system functionality to explore social interaction and urban space perception. Indicative questions include:

- Do users gain value from other, non-functional and more "social" or epistemic aspects of the system?
- Do users attach value to the collective sensing and content-generating activities on which the reward system is based?
- Did spontaneous social interaction and meaningful social behavior emerge during navigation as a result of having used the system?
- What are the effects of location-awareness on individual behavior and social interaction?
- Are there changes in how users perceive of the urban space and inter-city mobility, as a result of using the MITOS platform together with the SmartCity infrastructure?

3.3. Methodology

Given the flexibility of the concept of UX, an evaluation methodology that relies solely on quantitative methods is bound to be inadequate if the aim is to provide a thorough and holistic view of a system's use. Therefore, *mixed research designs* provide an optimal array of methods by virtue of combining the precision and clarity of quantitative measurements with the breadth, depth, and versatility of qualitative methods.

Additionally, for the purposes of our study the design framework has been divided in three distinct stages: pre-use, during use, and post-use. While the core of user experience will be the actual experience of usage, this does not cover all relevant UX concerns. People can have indirect experience *before* their first encounter through expectations formed from existing experience of related technologies, brand, advertisements, presentations, demonstrations, or others' opinions. Similarly, indirect experience extends *after* usage, for example, through reflection on previous usage, or through changes in people's appraisals of use [25]. We will proceed to explain the rationale and techniques of each method used.

The sample size is yet to be specified. However, qualitative methods will by necessity be applied to a small sample size. Quantitative methods, such as post-usage questionnaires, are more suitable for administration to a larger sample size. Lastly, since data regarding aspects of the users' activity will be captured by the system, the sample size for this particular category of data will be higher than that of the other

methods described in this section. Essentially, the total population of users of the application will be providing data automatically.

3.3.1. Pre-use methods

The following research techniques aim to provide indications of users' expectations of the system and projections regarding its impact on their experience of the surrounding environment. The combined objective of using these research techniques is to enable *real-time in-field* observation of users and recording of their experience as they perform tasks with the system, therefore to bring the evaluation into the context rather than relying only on retrospective evaluations. This approach will not only provide indications as to the complexities faced during actual system use, but it will also yield "thicker" data of an ethnographic nature that can complement self-report post-usage and pre-usage data.

3.3.1.1. Input survey

Before the system is put into use and during the initial phase of system design, an e-mail survey will be conducted with potential system users with the aim of drawing useful user-centered insights that may inform designers during the system design process, but also may provide useful input to evaluation researchers during the design of the research protocol. Participants will be selected randomly from within the total population of Santander residents (long- or short-term) who are mobile phone users.

3.3.1.2. General survey

A general survey will be conducted to gather data on subjective pre-adoption perceptions, beliefs, expectations and attitudes of potential MITOS users. Questions included in the pre-use survey will cover the following: demographics (gender, age, occupation, educational level, etc), patterns of public transportation usage (frequency and primary purpose of using public transportation, frequency of planning a trip using web or mobile services, access to personal vehicle, etc.), past use and familiarity with technology (experience using various information technology devices, computers, Internet, smart phones, use of applications, accessibility to various devices, etc.), pre-adoption expectations from both MITOS and SmartSantander, pre-adoption perceptions and assumptions concerning the system's value (functional, epistemic, social), as well as primary motivations for using the system and participating in the research project. This pre-use survey will also help in the process of screening participants and selecting a representative subset of subjects to take part in the post-use phase of the evaluation process. It will also guide the customization of questions for subsequent research protocols (surveys, interviews, focus groups, observation).

3.3.1.3. Think Aloud exercise

The Think Aloud approach [20] is useful in giving access to spontaneous users' reactions in their first encounter with the system. Before starting data collection, the system will be demonstrated to participants, who will be encouraged by researchers to apply the Think Aloud approach and verbally express their spontaneous thoughts while trialing the platform on their devices. Their interaction behavior with the system will be filmed for the analysis (the camera focusing only on their hands and the mobile device and recording their verbal commentary without showing their face). Each participant's verbal descriptions will be coded into different themes which will be aligned with the research questions and the operationalized definitions of the research framework.

3.3.2. *During-use methods*

Logging data, Staged Usage Situations and Experience Sampling will be three different techniques for data collection during the actual usage of the MITOS system. To date, the evaluation of UX has been mainly conducted with qualitative methods that focus on an applications' usability. These studies are typically conducted within a limited time span in controlled laboratory environments, conditions that do not resemble users' natural daily environments. The results of such evaluations may help to discover the mobile application's serious and immediate usability issues in a design, but they may not help to uncover issues that are relevant to real-life situations in the world outside the lab.

3.3.2.1. *Data logs*

Logging has been used in several usability studies to keep track of what is happening during the experimental use of technological systems. In our study we will mainly use logging as a support for the qualitative observations made during the test, but some data, such as time to complete, number of turns, exchange of data such as text messages and multimedia content, will be subject to statistical analysis as well. Subsequent analysis of logging data may yield metrics such as number of errors per user, average time for task completion, usage frequency etc. Additionally, information in traffic conditions and parking availability can be straightforwardly collected by sensors already installed. While the data collected from server logs are high in ecological validity, they do not really provide access to how users think and feel about their encounter with the system. Staged Usage Situations and Experience Sampling will be deployed to address the need for a more contextualized depiction of actual system use.

3.3.2.2. *Staged usage situations*

This method lies in exposing randomly selected users with concrete problem-centered tasks via a series of hypothetical mobility situations to see how they respond while using the system "out in the wild". A number of usage situations will be developed to match the whole range of possible system responses in action and the different dimensions that make up the UX construct. Fully disclosed researchers will follow selected users during experimental sessions, having the roles of Observers (taking notes on the observed behavior), Facilitators (setting up the infrastructure & helping with usability issues), and Partners for informal conversations (soliciting feedback, probing and discussing intelligent questions to elicit users' spontaneous, on-the-spot experiences with the system). An advantage of this method is that events in the environment may trigger the discussion – something which may also be a weakness in case the external events are disturbing. After each session, users will be asked to write down evaluative statements about the contexts of use and their interactions and experiences with the service. Research data drawn from this technique will reveal goal-related aspects which represent primarily the semantics of the system that convey meaning in the conversation between the user and the system. They will also try to capture a user's mental mode and what is sometimes referred to as the user's conceptual model. Ideally, a user's mental model matches the user model the designer has created [11].

3.3.2.3. *Experience sampling method*

This method is based on occasional mini-surveys, which can be administered to system users through their mobile devices over specific time intervals, after particular events,

or at random [14]. Participants will be asked to report about their experience real-time, through prompts for feedback and subjective ratings, while they are “in the field” using the system in naturalistic settings. Questions will mostly be of a yes / no type, appropriately designed to be quickly replied by pressing a few keys and should focus on user experience from the application, the smart city infrastructure, social context, mobility level, etc. To limit the obtrusiveness of this method, participants will be given the option to disable such prompts.

3.3.3. Post-use methods

Post-use methods can be both qualitative (e.g. focus groups, questionnaires featuring open-ended questions, etc.) and quantitative (questionnaires, analysis of logged data etc.). Interesting clues regarding the users’ spatial experience and navigation of an environment will also be provided by analysing the routes followed by the users. More specifically, we will be conducting post-use surveys, complemented with one-to-one interviews and group discussions. These are all self-report data collection techniques aiming to capture UX through rich subjective descriptions and evaluations, at a cumulative, reflective level (not possible through logging or observational data). Research questions will be designed to elicit subjective evaluations of the overall UX and its constituting dimensions (pragmatic, emotional, cognitive), but also to reveal areas of difficulty, patterns of use, intention to use, motives and suggestions for improvement.

While questionnaires will be used to gather data for quantitative analysis, semi-structured interviews (having a set of pre-defined questions but allowing for follow-up questions and discussions depending on the user’s answers) will allow us to clarify inconsistencies and identify causalities and relations specific to each particular user. The flexibility of the semi-structured interview approach will further enhance user’s “freedom” in verbalizing his experience from having used the MITOS system and allow researchers to make the most of the idiographic approach for understanding the meaning of contingent, unique, and subjective phenomena of quality of experience for each particular user. Given a population of users, an analysis could then be conducted within this for MITOS application, or between populations of users of different mobile applications. The same semi-structured approach will be applied in the “group interviews” (focus-groups) which will be conducted with MITOS users after they have used the system.

As far as data analysis is concerned, both qualitative and quantitative analytical techniques will be used. Data gathered from survey questionnaires (both pre-usage and post-usage surveys) will be analyzed quantitatively, while data gathered from interviews, focus groups and open-ended questions in questionnaires, in situ observations and micro-blog comments and images uploaded by users themselves, will be analyzed qualitatively. However, it may be the case that qualitative data drawn mostly from interviews will be quantified and subjected to quantitative analysis, while quantitative data could be used for generalizing qualitative findings. The interplay between qualitative and quantitative methods is compatible with the mixed methods design on which this project is based.

The combined use of qualitative and quantitative frameworks serves the mutual validation and convergence of the results arising from different evaluation methods (triangulation). In other words, results gathered from post-use methods will be analyzed to validate the findings from data collected through pre-use and during-use research.

Qualitative data collected through interviews, focus groups and in situ observation, will be correlated against findings from quantitative data collected through surveys and patterns gleaned from data logged in the application and service infrastructure. Correlated data will be used to generalize the UX with the system.

The above-discussed methods probe different aspects of the mobile usage situation. On the whole, the use of several methods in combination is necessary in order to obtain a good understanding of the user experience. Although longitudinal methods are good for existing technology, they tend to be difficult to use in the design process due to time limitations. Instead, one often has to probe potential future use by shorter tests and design appropriately designed experimental activities. In doing so, it is important to use a variety of methods, and to make use of both qualitative and quantitative approaches.

4. Future work

At present, system design is being finalized and technological development is at the finishing stages. The project will continue with a field experiment for the purpose of evaluating of UX factors in the context of a location-based game-like activity incorporating the elements described in sections 1 and 2. Rich and varied data, both quantitative and qualitative, are expected to be extracted as a result of this activity. A mixed methods perspective will be adopted for data analysis, since an optimal combination of quantitative and qualitative methods is necessary for a holistic and accurate investigation of mobile UX [8-9].

The conclusions that will be arrived at as a result of the field experiment are expected to reinforce our understanding of the role of citizens / commuters as providers of information on traffic, transportation, and environmental conditions, illuminate the dominant factors and underlying processes that influence mobile UX, and clarify the process of social behavior as affected by the use of mobile media.

References

- [1] J.W. Creswell, *Research Design: Qualitative, Quantitative, and Mixed Methods Approaches* (3rd edition), Sage, Thousand Oaks, CA, 2009.
- [2] N. Crilly, J. Moultrie, P.J. Clarkson, Seeing Things: Consumer Response to the Visual Domain in Product Design. *Design Studies* **25** (2004), 547-577.
- [3] N. Crilly, J. Moultrie, P.J. Clarkson, Shaping Things: Intended Consumer Response and the Other Determinants of Product Form, *Design Studies* **30** (2009), 224-254.
- [4] M. Czikszenmihalyi, M. *Finding Flow: The Psychology of Engagement with Everyday Life*. Basic Books, New York, 1997.
- [5] O. Demirbilek & B. Sener, Product Design, Semantics and Emotional Response. *Ergonomics* **46** (2003), 1346-1360.
- [6] P. Desmet, P.. Measuring Emotion: Development and Application of an Instrument to Measure Emotional Responses to Products. In M.A. Blythe, K. Overbeeke, A.M. Monk, P.C. Wright (eds.), *Funology: From Usability to Enjoyment*, Kluwer Academic Publishers, Dordrecht, 2004, 111-123.
- [7] P. Desmet & P. Hekkert, Framework of Product Experience, *International Journal of Design* **1** (2007), 57-66.
- [8] K. Diamantaki, C. Rizopoulos, D. Charitos, N. Tsianos, (2009) "LOCUNET: Location-based Games as Media Communicating Social Meaning". In A. Souza e Silva, A. & D. Sutko (eds.), *Digital Cityscapes: Emerging Digital and Urban Playscapes*, Peter Lang, New York, 2009.

- [9] K. Diamantaki, C. Rizopoulos, D. Charitos, N. Tsianos, Theoretical and Methodological Implications of Designing and Implementing Multi-user Location-based Activities. *Personal and Ubiquitous Computing* **15** (2011), 37-49.
- [10] P. Dourish, *Where the Action Is: The Foundations of Embodied Interaction*, The MIT Press, Cambridge, MA, 2001.
- [11] C. Harrison, S. Medrington, W. Stransom, User-Centered Design Research Methods for Mobile Industry Practitioners, *Journal of Mobile Media*, Spring 2011 [URL: <http://wi.hexagram.ca/?p=67>].
- [12] M. Hassenzahl, S. Diefenbach, A. Göritz, A. Needs, Affect, and Interactive Products – Facets of User Experience, *Interacting with Computers* **22** (2010), 353-362.
- [13] M. Hassenzahl & N. Tractinsky, User Experience – A Research Agenda. *Behaviour and Information Technology* **25** (2006), 91 -97.
- [14] J.M. Hektner, J.A. Schmidt, M. Csikszentmihalyi, M. (eds.). *Experience Sampling Method: Measuring the Quality of Everyday Life*. Sage Publications, London, 2006.
- [15] ISO 9241, *Ergonomic Requirements for Office Work with Visual Display Terminals (VDTs) – Part 11: Guidance on Usability*, International Standardization Organization, Geneva, Switzerland, 1998.
- [16] S. Kujala, V. Roto, K. Väänänen-Vainio-Mattila, A. Sinnelä, A. Identifying Hedonic Factors in Long-Term User Experience. *Proceedings of DPPI'11*, 22-25 June 2011, Milan, Italy, New York: ACM Press.
- [17] M. Kuniavsky, User Experience and HCI. In A. Sears & J.A. Jacko (eds.), *The Human-Computer Interaction Handbook: Fundamentals, Evolving Technologies, and Emerging Applications* (2nd edition), Lawrence Erlbaum Associates, New York and London, 2008, 897-916.
- [18] B. Laurel, *Computers As Theatre*, Addison-Wesley, London, 1993.
- [19] E. Law, V. Roto, M. Hassenzahl, A. Vermeeren, J. Kort, Understanding, Scoping and Defining User Experience: A Survey Approach. In *Proceedings of Human Factors in Computing Systems (CHI'09)*, 4-9 April 2009, Boston, MA.
- [20] C. Lewis & J. Rieman, *Task-Centered User Interface Design: A Practical Introduction*, 1994 [URL: <ftp.cs.colorado.edu/pub/cs/distribs/clewis/HCI-Design-Book>]
- [21] J. McCarthy & P. Wright, *Technology As Experience*, The MIT Press, Cambridge, MA, 2004.
- [22] D.A. Norman, *Emotional Design: Why We Love (or Hate) Everyday Things*. Basic Books, New York, 2004.
- [23] P. Sengers. The Engineering of Experience. In M.A. Blythe, K. Overbeeke, A.M. Monk, P.C. Wright (eds.), *Funology: From Usability to Enjoyment*, Kluwer Academic Publishers, Dordrecht, 2004, pp. 19-29.
- [24] D. Tsolkas, N. Passas, C. Xenakis, V. Papataxiarhis, V. Tsetsos, Busfinder: A Personalized Multimodal Transportation Guide with Dynamic Routing, *Proceedings of PCI 2012*, Piraeus, Greece, 2012.
- [25] A.P. Vermeeren, E. Law, V. Roto, M. Obrist, J. Hoonhout, K. Väänänen-Vainio-Mattila, User Experience Evaluation Methods: Current state and Development Needs. *Proceedings of NordiCHI 2010*, Reykjavik, Iceland, 16-20 October 2010.
- [26] K. Salen & E. Zimmerman, *E. Rules of Play: Game Design Fundamentals*. Cambridge, MA: The MIT Press, 2004.
- [27] B. Laurel. *Computers As Theatre*, London: Addison-Wesley, 1993.
- [28] S. Deterding, D. Dixon, R. Khaled, L. Nacke. From Game Design Elements to Gamefulness: Defining “Gamification”. *Proceedings of MindTrek'11*, 28-30 September 2011, Tampere, Finland, New York: ACM Press, 2011.
- [29] T.W. Malone. Heuristics for Designing Enjoyable User Interfaces: Lessons from Computer Games. In *Proceedings of the 1982 Conference on Human Factors in Computing Systems (CHI'82)*, pp. 63-68, New York: ACM Press, 1982.
- [30] K. Huotari & J. Hamari. "Defining Gamification - A Service Marketing Perspective". *Proceedings of the 16th International Academic MindTrek Conference 2012*, Tampere, Finland, October 3-5, 2012.
- [31] G. Zichermann & C. Cunningham (August 2011). "Introduction". *Gamification by Design: Implementing Game Mechanics in Web and Mobile Apps* (1st ed.). Sebastopol, California: O'Reilly Media. p. xiv.
- [32] A. Marczewski (April 2012). *Gamification: A Simple Introduction & a bit More: Tips, Advice and Thoughts on Gamification* (2nd ed.), Kindle edition.

Privacy in Intelligent Environments: That obscure object of desire

Spyros AMPANAVOS^a and George PAPOULIAS^b

^a*NTUA Architect Engineer*

^b*NTUA Architect Engineer*

Abstract. Intelligent Environments are tightly connected with the extended flow of information to and from their users. Their constant need for data together with the desired unobtrusive character put the issue of privacy in stake. As mapping public and private space in the way Nolli did in 1748 is not possible anymore, a contemporary cartography of privacy is sought. This leads to the awareness of a new state of privacy. Through the use of a case study we propose a model that aims to offer anonymity and control of information. Weaknesses do exist and we recognize that much has yet to be done, in both technical and legal aspects.

Keywords. Privacy, informational self-determination, public space, private space, ambient intelligence, surveillance, data flow

Introduction

It is more and more evident that intelligent systems which gradually embrace and support our everyday activities are imposing a new perception of personal data and privacy. Nowadays more than ever before, personal information have acquired a catalytic role in our information-based society. We acknowledge that information is the corpus of intelligent environments, yet the borders of individuals' privacy are constantly trespassed. We believe that as the traditional distinctions between private and public seem to corrode in front of Ambient Intelligent devices and sensors, the need for an intelligent informational privacy arises.

1. Intelligent Cities and the increasing flow of information

Context-aware computing offers the promise of significant user gains - the ability for systems to adapt more readily to user needs, models, and goals (Ackerman et al). In this paper the Intelligent City is perceived as a responsive environment, which is able

to adapt to the users' individuality, through the use of context-aware processes. Intelligent environments are in a continuous adaptation to the various needs of different groups of people. Their response to users' everyday activity, problem solving or sophisticated and well studied interventions are based on previous experience; new concepts are synthesized upon the basis of old concepts that are seen and assimilated in new ways.

Therefore, a basic prerequisite for the environment's adaptability seems to be the continuous flow of information. Users' personal data collected through networks are identified and analyzed by intelligent software.

In his book "Me++", William Mitchell describes the contemporary man as a biological organism extended by various networks. Each person is part of these networks; man utilizes them, while networks also make use of him at the same time. Such networks gradually become parts of our body, offering augmented senses, like extended vision or hearing. They extend our range of actions, transferring the action field almost anywhere - at least at any place we can be connected with. Such a potential however, might also act reversely. One person's sensor is another person's spy (Ackerman). While retrieving data, various types of information are sent to nodes of the network - users unwittingly leave digital footprints. Activities online already get tracked routinely, and in detail (Mitchell).

On the other hand, as intelligent environments are established, ubiquitous computing prevails. Users interact with their environment through minimized and gradually integrated interfaces. Uninterrupted service relies on this unobtrusive interaction between the system and its users. Nevertheless, this could possibly lead to an uncontrolled flow of personal data to every direction. For that, the passive collection and logging of information related to users' activities, information access patterns, movement, etc., all raise serious privacy concerns.

The information flow requires some friction in order to keep firm the distinction between the multiagent system (the society) and the identity of the agents (the individuals) constituting it.

2. Mapping a new state of privacy

A digital environment aiming to be transparent results in an increasing surveillance of its users. That new condition of ubiquitous tracking, the prompt for people to reveal more and more is a really shaking shift to a new definition of social and private life. The unprecedented flow and dispersal of information and personal data raises controversial issues concerning the identification of private and public territories both in physical and informational space. Privacy should be redefined in a new context.

In 1748 Giambattista Nolli engraved the *Pianta Grande di Roma*, an iconographic plan of Rome. The Nolli Map, as it is universally known, is using a dark color to represent the built, shady, private space of blocks and buildings, while open air and enclosed public space (such as cathedrals or the Pantheon) is noted in white.

Nowadays, it gets more and more difficult to create such a cartography of the contemporary city. This is not due to the increase of the number of public buildings, nor due to the change of use that these buildings would have (for example shopping malls should appear instead of churches in a modern version of the map). What makes

this kind of representation problematic is that in contemporary life, the thin line between public and private tends to become blurred.

Television was the first step to bringing public space into one's home, through its projection on the screen. Its successor, the Internet, changed this one-way flow of data to a bidirectional, interactive communication. One can participate in a public conversation without physically leaving the privacy of his house. What's more, would this conversation be a video conference, he would expose himself, together with an image of his private environment being in the background, to the public. Thus, a temporary transformation occurs through the networked connection, driving each user to invade the others' "de-privatized" space. The exposure of one's self that takes place during such a process can hardly be compared to previously used ways of distant communication, as the dramatic increase of data transferred (sound, video instead of written text for example) leads to an inversely proportional control of the outbound data, even more because of the connection's synchronous nature. Conversely, a temporary private space can be created around a person, when someone uses headphones to make a personal video call through his smart phone from a public location, such as a park. The enclosing environment established is bound to him and will follow his route in the city. Walls cannot serve any more as a means to enclose privacy. Instead, the flow of information (both physical and digital) is the element that defines the degree of one's exposure. The allocation of different shades of constantly changing gray, instead of Nolli's black and white contrast, on a map would depend on occasional interaction scenarios.

The change in the aforementioned map helps us realize in a profound way the shift that has already occurred in the notion of privacy. Indeed, data related with every aspect of our lives are gradually detached from physical space and thus, controlling privacy coincides with the ability to manage our digitally stored information.

Information related with users' behavior, preferences and reactions compose a unique imprint of one's personality. These digital replicas, which are infinitely updated, suggest that one's informational sphere and one's personal identity are co-referential, or two sides of the same coin: "you are your information", so anything done to your information is done to you, not to your belongings.

Looking at the nature of a person as being constituted by that person's information allows one to understand the right to informational privacy as a right to personal immunity from unknown, undesired or unintentional changes in one's own identity as an informational entity, either actively – collecting, storing, reproducing, manipulating etc. one's information amounts now to stages in stealing, cloning or breeding someone else's personal identity – or passively – as breaching one's informational privacy may now consist in forcing someone to acquire unwanted data, thus altering her or his nature as an informational entity without consent. In the realm of information technology, the right of privacy has focused on the ability of individuals to control the collection and use of their personal information held by others. The German Federal Constitutional Court has described this as the right of "informational self-determination".

3. Defining a new context for privacy protection

In the pre electronic era, access to private space used to require some metal key that you inserted into a matching lock. Nowadays, metal keys are replaced by digital ones, which can have the form of passwords, and may give you access to various types of private space, from a building to your bank account or your e-mails. However, passwords already seem outdated, and access management seems to head towards the recognition of a person's physical characteristics (biometrics) in order to perform identification. This idea may be in accordance with an intelligent environment's non-obtrusive nature, but also raises severe issues of surveillance. As perceptual interfaces become commonly used in intelligent environments, the only way to face the subject of privacy seems to be through a combination of social, legal and technical consideration.

In order to conceptualize a system for improved privacy intelligence, we will consider the case of a person moving in the city. Some intelligent software is tracking her position - through a GPS system for example - keeping her informed about places and events within a close distance that may interest her. In order to offer targeted information related with specific user's interests and her current situation (on foot, car, single, married etc.), the software will need access to the user's database. Her food preferences may be utilized so as for the software to suggest the nearest restaurants that fit to user's taste, her favorite music may be used to make a highlighted list of relevant music bars, cafes and so on.

The problem is how user will remain anonymous through this process, and how she will make sure that any involved party will only get the necessary data.

We suggest that all personal data resources and security encryption should be located outside the intelligent environment, with trusted third parties. When the tracking application, or any of the approached stores' software ask for the user's information, a request is sent to the trusted third party. To ensure that references are secured, the application temporarily assigns the user with an alias. That way, the alias can be used to request information on behalf of the user without revealing her identity or further personal data. Context aware software attached to the aforementioned third party will evaluate the requested information, and will decide whether it should be provided, or, given that the request involves access to critical personal data, if permission from the user should be asked for. The decision would be taken by considering what privacy choice the user made the last time she entered that particular context, what privacy choices have the user's trusted colleagues made in the current context, and what privacy choices did the user make when dealing with the same data collector though in an otherwise different context. Consequently, this information is attached to the alias, through which the user is ready to interact in the specific environment.

The architecture of identity-management privacy maintains user's privacy through pseudonyms and secure identity management. Based on users' privacy preferences, this architecture allows them to be completely anonymous to both the environment and to other users. We hope that the choice offered for anonymity and control over the flow of their information will promote greater user confidence in ubiquitous computing systems, and improve the systems' ability to support social systems. It is hoped that this architecture will form the basis for future intelligent environment architectures.

Apparently, the suggested system - as described in the example above - implies a centralized model of intelligent responses. Yet, to many, this fundamental characteristic

is a strong drawback, which leads to increased system's vulnerability. In other words, it is feared that third parties which undertake the role of a buffering platform between individuals and other involved parties, cannot guarantee and protect effectively anonymity and after all individual's informational privacy. On the other hand, a decentralized model of intelligent environments is opposed; one that would make use of dispersed personal data protected by unique codes. Even if such an alternative entails time spent on identification procedures, "clustered IDs" system offers an improved differentiation. This represents a different approach that encourages the development of multiple identity management systems operating across different collections of businesses, government departments, and so on, and facilitates the management of related informational accounts.

To conclude, we believe that in order for both centralized and decentralized intelligent environments to adequately protect one's right for informational self-determination and privacy, a context should be imposed emphasizing on the following directions:

- **Notice:** The individual should have clear notice of the type of information collected, its use, and an indication of third parties other than the original collector who will have access to the data.
- **Choice:** The ability to choose not to have data collected.
- **Access:** The ability for the data subject to see what personal information is held about him/her, to correct errors, and to delete the information if desired.
- **Security:** Reasonable measure taken to secure (both technically and operational) the data from unauthorized access.

The previous guidelines have also been issued by the Federal Trade Commission (FTC 2000) of the US, a fact that further illustrates the importance of individual's privacy in future intelligent and interactive environments.

References (Bibliography)

- William J. Mitchell, "City of Bits; Space, Place and the InfoBahn", the MIT Press 1996
- William J. Mitchell, "Me++ the Cyborg self and the networked City", the MIT Press 2003
- Nicos Komninos, "Intelligent Cities: Innovation, Knowledge Systems, and Digital Spaces", Spon Press 2002
London
- David Lyon, "Surveillance Society Monitoring everyday life", Open University Press 2001
- Phillip E. Agre, Marc Rotenberg, "Technology and Privacy: the new Landscape", the MIT Press 1998
- Manuel Gausa, Vincente Guallard, Willy Muller, Fedrico Soriano, Fernando Porras, Jose Morales, "the Metapolis Dictionary of Advanced Architecture – city, technology and society in the information age", Actar Birkhauser Distribution, 2003
- Pato, J. (2003). Identity management: Setting context. Encyclopedia of Information Security (Summer/Fall)

Mark Rotenberg – director of the “Electronic Privacy Information Center” USA, “Preserving Privacy in the Information Society”, UNESCO
http://www.unesco.org/webworld/infoethics_2/eng/papers/paper_10.htm

Juan Carlos Augusto, Hideyuki Nakashima, Hamid Aghajan, “Ambient Intelligence and Smart Environments: A State of the Art”

Rita Cucchiara , Andrea Prati , Cesare Osti, Stefano Pavani, “Ambient Intelligence in Urban Environments”

Mark Ackerman, Trevor Darrell, and Daniel J. Weitzner, Privacy In Context

Luciano Floridi, Four Challenges for a Theory of Informational Privacy

Sen-Sys: visualizing real-time user displacement patterns in urban environments

Patricia CORREA, Alejandra ROMO, James YAMADA
Graduate School of Design, Harvard University

Abstract. Understanding the specific qualities of dynamic factors that shape how urban environments work is important to analyzing these environments effectively. Prominent among these factors is the movement of people and the patterns or trends that emerge from that movement over time. In order to better study movement as a dynamic factor in how urban spaces work an academic project titled *Sen-Sys* (for its use of personal GPS sensors to map dynamic urban systems) was designed and implemented to a limited degree over the course of a semester to produce a movement-based model in which the proportions of urban areas are dynamically distorted to reflect areas of high and low occupation to reflect moment-to-moment spatial behavior and visual elements are generated to reflect recurring trends in movement over of time. This paper provides an overview of *Sen-Sys*, frames it in relation to similar existing work and discusses its conceivable strengths, limitations and directions for future development.

Keywords. real time control systems, wireless locationing, real time computation, sensing space, visualization platform

Introduction

Smart cities may someday adapt to their users needs by exploring the tensions, interactions, emergent clustering and dissipations of their users. For now, however, urban spatial compositions often do not meet the requirements of current users, necessitating their eventual physical change. This issue is exacerbated by the tendency for those who affect the spatial composition of cities (city planners, for example) do not have access to tools that allow them to perceive the specific qualities of dynamic factors within those cities, let alone the nature of patterns or trends that emerge from the repetition of those factors over time. Looking at this problem in light of existing sensor technology, what tools might help organizations and individuals study dynamic relationships between people and place? *Sen-Sys* attempts to answer this question: movement-based visualizations of urban areas may allow the study of cities as systems that embody highly dynamic conditions rather than as systems that respond to those conditions at an otherwise glacial pace. In mapping the displacement of people in relation to the existing city grid, the location of each individual is represented by a persistent data point. The aggregation and dispersal of these particles shifts the proportions of the city grid: over-utilized spaces expand and the under-utilized spaces compress.

The accumulated data may provide insight into the dynamic spatial behavior of people in urban areas. Recognizing trends or patterns over time, establishing paths and correlating physical behaviors with environmental factors may provide guidance to

organizations and individuals practicing architecture, social science or urban planning. This method accumulates changing information about the city as an emergent system in order to visualize urban areas through the lens of displacement and movement patterns. This empirical data of user flow and occupancy will serve as a base to study real time dynamic relationships embedded within these urban patterns. In this approach, the global position of the user in real time is essential to the data processing of the platform. There are many methods to acquire, store and process this data and recent initiatives will be discussed in the following paragraph. Our method involves the deployment of an app designed for Android phones which sends GPS information to a web storage system and is then processed in a C# digital platform. The feasibility of this approach lies in the fact that no specialized hardware is required for data capture as any user with an Android phone can become a voluntary and nearly continuous GPS data source by simply downloading the necessary software. Furthermore, the web storage system allows for easy and accessible processing of real-time data. In this sense, the structure of the platform can become open-source, scalable and editable via updates.

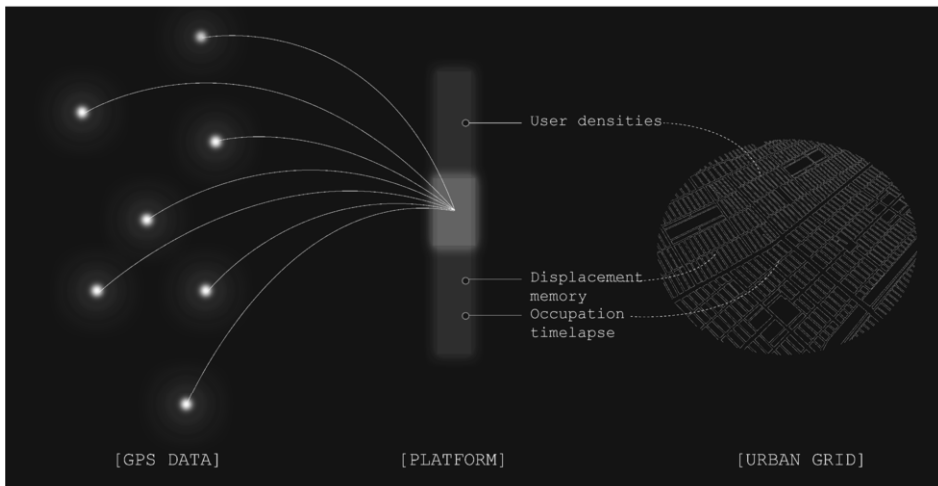

Figure 1. Using an opt-in mobile phone app that uses GPS to report the users exact latitude and longitude and an interface to graphically navigate this data in real time to achieve conclusions.

1. Background

Understanding how people use public space and their displacement within the urban fabric is the central subject of this research. Foundations of this study can be found in the field of proxemics which is defined as "the interrelated observations and theories of man's use of space as a specialized elaboration of culture"[1]. It was the cultural anthropologist Edward T. Hall who invented the term proxemics and noted its applicability as an evaluation of user spatial interaction and ultimately the organization of the public space. Hall describes his work in *The Hidden Dimension* as an attempt to "provide such an organizing frame for space as a system of communication, and for the spatial aspects of architecture and city planning"[1] In the context of this paper, the value of this organizing frame lies primarily in understanding the patterns of human

displacement for classification, path establishment and the correlation of physical behaviors with the urban environment.

Recent research on the patterns of urban mobility has been developed by the physicist Albert Laszlo Barabasi. In his book *Bursts*, he begins the initiative to study anonymized mobile-phone data in the context of users' behavioral patterns and their underlying social networks[2]. The patterns within the data yielded some interesting results which Barabasi describes as following: "It's not that there are two groups of users, a group of numerous individuals who travel little and a smaller group of people who cover hundreds of miles on a daily basis. The power law describes a continuum between the two groups: There is a very large number of individuals who truly confine their mobility to a neighborhood of two miles or less. There are fewer, but still many, whose radius is about ten miles, and even fewer who move about fifty miles daily. These folks coexist with an even smaller group of people who are spread widely, covering hundreds of miles. In this respect, Richardson's formulation is appropriate: the larger, the fewer. The farther you travel regularly, the fewer individuals you will find like you". Other recent initiatives exploring pattern recognition through mobile-phone technology have been deployed by the Senseable City Lab at MIT. Using anonymous data from mobile cellular networks interpolated with real time public transport positioning provided valuable information regarding the patterns of urban mobility[3]. The visualizations generated through this platform become primarily a research resource to understand how digital technology derived applications could provide a deeper understanding of urban dynamics. Furthermore, the processed and presented data gives users "more control over their environment by allowing them to make decisions that are more informed about their surroundings, reducing inefficiencies of present-day urban systems"[3]. The data collection from both of the previous examples relied primarily on direct access to mobile network information.

Another interesting data collection method, explored in recent research by Suleiman Alhadidi, is through Microsoft Kinect technology where image recognition tools and techniques enable real time processing and storage of very rich and accurate data[4]. However, this method has a significant disadvantage in larger scale urban deployments due to the current challenges of physically installing the necessary hardware within urban space. A third method for data collection is explored in this project and it relies on a GPS tracking app embedded in Android mobile devices that stores information on the web.

2. Methods

Sen-Sys is a digital platform that acquires global positioning of users in urban space and applies this data to visualize both real time and time-lapse patterns. The first step in the method of acquiring data begins with the creation of an application suitable for Android phone hardware. The design and deployment of this app is developed through MIT's App Inventor. The app is then downloaded and installed to an Android phone by an individual, and GPS data is then captured with three variables for each position: latitude, longitude and a timestamp. This information is stored in JSON format on the online platform Geonecta.com. Although there are a variety of well-known sensor information storage websites such as Pachube (now XIVELY), this project used a small scale and local web platform to deploy and manage our network of GPS data. Since this data input is written in JSON format, it must be translated into C#

code so it can be processed into visualizations through Grasshopper for Rhino software. A component that parses a string of objects is created, with each object representing a set of coordinates. This string is updated every time the URL is refreshed providing a growing history of an individual's spatial data. The string is transformed into a moving particle by taking the coordinates of the GPS sensor at regular intervals of time and writing them out as points (x-y grid within a boundary constraint with z set at 0,0). Real displacement is then visualized in a compressed representation of time - GPS location displacement over several hours or days could be compressed into a few seconds by a user's choosing.

The urban space is then visualized as constantly shifting in proportion in response to aggregate particle spatial behavior. The growing history of an individual's GPS coordinates can also be developed into visual elements that indicate a displacement history. The aggregated visualization of these user displacement histories emphasize the highly recurring paths within the examined urban space. GPS values also inform real-time continuous morphing of a topographical mesh where the highest Z values are representative of the longest time spent by single or collective users in fixed locations. This visualization may become useful in analyzing time invested by users in specific places within urban areas.

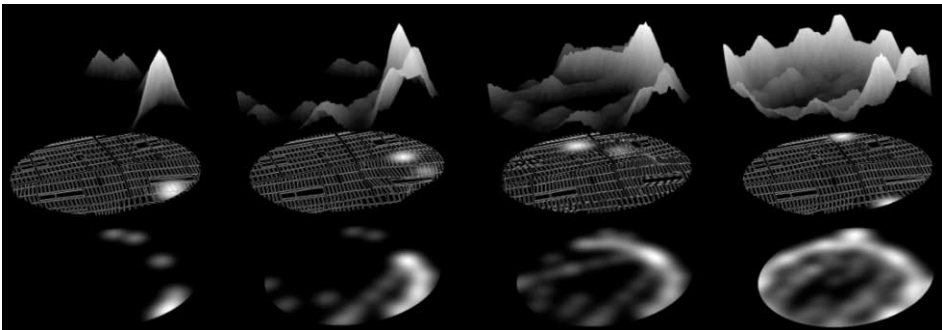

Figure 2. Topographical mesh generation through the accumulation of data.

3. Discussion

As a tool for studying spatial behavior in urban areas, Sen-Sys has both strengths and limitations in how it has been designed thus far, and there are implications that arise from these issues that would in turn direct future development. Because Sen-Sys utilizes software that can be readily downloaded and installed on personal devices that many people carry with them on a regular basis, it does not require the production and distribution of physical equipment. This arguably makes its implementation more affordable and logistically feasible than if it were to utilize devices manufactured for the specific purpose of studying urban movement patterns. The software could be made free to download, and keeping an app on a Smartphone is easier than carrying a separate device on one's person at all times. However, people would likely have to be provided (and convinced of) benefits for downloading such software, particularly in light of the fact that regular GPS activity will drain a Smartphone's battery at a faster-than-otherwise rate. There may also be a perception by

members of the public that they are giving up their privacy to someone that is using Sen-Sys as a tool for study, despite the fact that their location and movement data would be anonymized.

These two limitations set up an interesting hypothetical problem: Perhaps the most compelling possible benefit for people to download Sen-Sys tracking application would be their access to aggregated Sen-Sys data through the same application. Participants would then directly experience the result of their participation in Sen-Sys, becoming its users in rather than only its contributors and seeing their own cities in new and critical ways. However, there are privacy issues here: users would likely learn to recognize point data representing family, spouses, neighbors or close friends despite its anonymization. Point data would likely have to be excluded for the individual Sen-Sys user, but may be acceptable for organizations to whom that data may prove valuable such as local government bodies, planning agencies or academic institutions. The question of what Sen-Sys should show and to whom leads this discussion to this tool's interface, within which there are both more questions and possible directions for future development. There would likely have to be two interfaces - a simplified version for private Smartphone users and a more complex, more comprehensive version for organizations that address planning issues. Both would need to visualize comparisons between spatially distorted urban areas and those areas in their original proportions in order to provide meaningful data. Both would need to show various layers of information to help users and organizations to draw correlations between spatial behavior and environmental factors (such as weather, pollution, civic events, crime, transit routes, zoning etc.), and those layers could be controlled through customizable filters for readability and relevance to the individual. Conceivably, user surveys could be conducted through the Smartphone application in order to create a visual correlation between attitudes towards particular places and movement (e.g. "On a scale of 0 to 10, how much do you appreciate 1) where you came from, 2) where you are and 3) where you are going?"). App-facilitated surveys of user sentiment toward specific aspects of their cities may also give organizations stronger insight into the nature of unclear issues that they are trying to analyze with Sen-Sys.

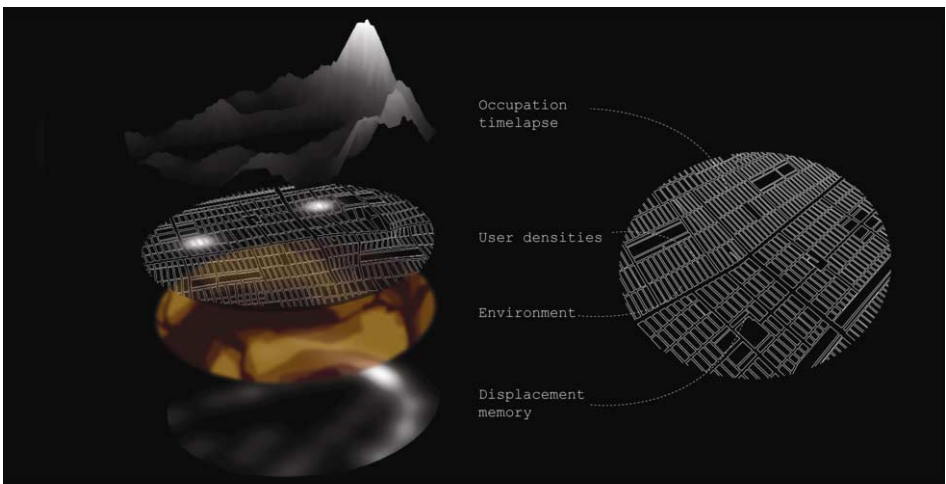

Figure 3. Interpolating environmental data with user displacement data and attitude data provides deeper layers of information on the dynamic relationships between people and place.

4. Conclusion

Sen-Sys is at an early stage and could be further developed to help individuals and organizations better understand user spatial behavior within urban areas. Furthermore, the platform has the potential to interpolate environmental data with user displacement and survey responses, providing deeper layers of information on the dynamic relationships between people and place. These relationships may provide interesting design parameters, particularly for computational design strategies. Of course, Sen-Sys would be designed to show correlations between these different forms of data but determining the causation behind this data will still be left to the judgment of those using it as a study tool. Perhaps it will be Sen-Sys' responsibility to somehow remind users of that distinction through its visualizations and interfaces while at the same time providing valuable dynamic information for critical urban analysis.

5. Acknowledgements

The authors would like to sincerely thank Panagiotis Michalatos for all of his patience, guidance and assistance, as well as Fernando Tubilla Kuri and Federico Villalpando for their assistance and for opening up Geonecta.com to our efforts.

References

- [1] Hall, Edward T. (1966). *The Hidden Dimension*. Anchor Books. Garden City, NY.
- [2] Barabasi, Albert-Laszlo. (2010). *Bursts*. Dutton. New York, NY.
- [3] Calabrese, F., Colonna, M., Lovisolo, P., Parata, D. and Ratti, C.: 2011, Real-Time Urban Monitoring Using Cell Phones: A Case Study in Rome, *IEEE Transactions on Intelligent Transportation Systems*, 12(1), 141–151.
- [4] Alhadidi, Suleiman.: 2013, *Generative Design Intervention: Creating a computational platform for sensing space*.
- [5] J. Reades, F. Calabrese, A. Sevtsuk, and C. Ratti, "Cellular census: Explorations in urban data collection," *Pervasive Comput.*, vol. 6, no. 3, Jul.–Sep. 2007.

This page intentionally left blank

1st International Workshop on Cloud-of-Things (CoT'13)

Jeannette Chin (Anglia Ruskin University, United Kingdom)

Vic Callaghan (Essex University, United Kingdom)

This page intentionally left blank

Cloud-of-Things 2013 (CoT'13)

Athens, Greece. 16-26th of July 2013



The Cloud-of-Things 2013 (CoT'13) is the first in a series of workshops that will explore the synergy offered by combining the Internet of Things, Cloud Computing, Intelligent Environments and embedded computing which are often discussed separately, each at their own specialist conference. The reasoning behind bringing these topics together is that we foresee practical deployments of such systems are likely to need combinations of these techniques from these hitherto separate research areas. As a response, the Cloud-of-Things workshop was formed to provide an opportunity for researchers from these areas to come together to discuss the issues in a more holistic way, so as to identify possibilities for synergy and cross-fertilization. This area of work is fuelled by massive market opportunities as, for example, some estimates suggest that this market could be worth between 22 billion and 50 billion dollars (made up of some 16 billion connected devices) by 2020. These figures seem plausible as there are already said to be of the order of 8 billion embedded-processors and around 1 billion smart phones produced each year. Thus, we believe this workshop is providing a timely opportunity to discuss the opportunities for research in this strategically important area.

The Outer Limits

This year's event includes a special session, "*The Outer Limits*", sponsored by the "*Creative Science Foundation*" (www.creative-science.org) that includes a small number of presentations to take a speculative look at future possibilities for the Cloud-of-Things area. These presentations use the *Science Fiction Prototyping* approach.

Incidentally, the name for this session “*The Outer Limits*” was derived from an American TV series that aired during the period 1963 to 1965 which had an emphasis on depicting stories on the outer edges of our familiar world, through the use of science fiction. We hope attendees or readers will find this small session an interesting and useful addition to the workshop.

The workshop consisted of 13 peer-reviewed papers; 9 regular papers and 4 Science Fiction prototypes (SFPs). The regular papers cover an interesting mix of topics with the first paper by Anasol PEÑA-RIOS et-al describing an application that seeks to combine physical and virtual networked objects within a holistic cloud supported system that allows Internet-of-Things developers on distributed geographical sites to collaborate on shared work. The second paper by Chien-Ming TUN et-al examines the business drivers and issues that arise from massive cloud based systems by examining Google's operational model. The third paper from Alejandro Sosa et-al describes a solution to a fundamental problem (cyclic instability) that disrupts the proper operation of large interconnected Cloud-of-Things systems. The fourth paper by Markos ZAMPOGLOU et-al describes work towards a large-scale cloud-based platform that offers virtual reality advertisements to end-users. The fifth paper by Gary SCOTT et-al provides a fascinating insight into how the Internet-of-Things can enter people's everyday lives by creating innovative smart objects, illustrating the process via the design of an intelligent alarm clock. The sixth paper by Vasileios ANAGNOSTOPOULOS et-al enables enriched user content to be distributed (and redistributed) through a network of commercial and non-commercial services (Preservation Services), while ensuring a lasting relationship between the holder and owner of the intellectual content. The seventh paper by Idham ANANTA et-al explores how the massive user base of cloud based systems, that usually adds to complexity and problems, can be harnessed to provide a crowd-based intelligence that improves the performance of such systems. The eighth paper by Malek ALRASHIDI explores the use of augmented reality in untangling the complexities of large Cloud-of-Things systems both as an educational tool and as an aid to developers. The ninth paper by Marc DAVIES et-al provides an account of work that enables the automatic generation of realistic artificial human-like characters that can be used for next generation games or as test-beds for Cloud-of-Things applications needing very large numbers of test subjects or environments. Apart from the regular papers, we have also created what we think is a novel session called ‘*The Outer Limits*’. It is a small session of 4 creative science papers that we hope will stimulate some forward thinking about research into the Cloud-of-Things. The first of these papers is from Tiina KYMÄLÄINEN who introduces an intelligent home for the aged that uses Cloud-of-Things technology to provide motivational and personalized activities, assistance, and memory. It probes the boundaries of this area by studying a do-it-yourself creation and configuration tool. The second paper by Yu HUAN et-al explores a world where augmented realities are realised through bionic lenses. It raises some fascinating ideas about the relationships between the virtual and physical, creating a complex world where total immersion brings possibilities beyond living and death. The third paper by Yevgeniya KOVALCHUK explores the consequences of using Cloud-of-Things technologies to augment people's physical body, mind, and consciousness beyond their current biological limits. The final paper, by Victor Callaghan, provides an insight into the current interest in maker-spaces and their relationship to Cloud-of-Things technologies along with presenting 4 vignettes speculating on possible future directions of this area.

Clearly, we would not have been able to manage this workshop on our own and there are many people we need to thank. First, we would like to acknowledge the valuable contribution of our CoT'13 organizational team whose support and advice throughout the year has contributed greatly to the success of this event (especially their assistance with reviewing and revising papers), namely (in alphabetical order):

- Matt Ball, University of Essex, United Kingdom
- Susi Daryanti, Universitas Gadjah Mada, Indonesia
- Faiyaz Doctor, Coventry University, United Kingdom
- Bin Hu, Birmingham City University, United Kingdom
- Wolfgang Minker, Ulm University, Germany
- Massimo Poesio University of Essex, United Kingdom
- Angelica Reyes, Universitat Politècnica de Catalunya, Barcelona
- Jen Wu, National Taiwan University, Republic of China
- Victor Zamudio, Instituto Tecnológico de León, México
- May Zhang, Shijiazhuang University, China

Also, we are grateful to the IE'13 organisers who are hosting this event and our sponsors, the Creative Science Foundation. Finally, and most importantly, we want to thank all our authors as, without their outstanding work, there would be no workshop.

If you found this workshop proceedings useful, then why not join us for CoT'14 (keep your eye on www.cloudofthings.org for more information)

Jeannette Chin – Anglia Ruskin University (jeannette.chin@anglia.ac.uk)

Vic Callaghan – Essex University (vic@essex.ac.uk)



8th June 2013

Developing xReality objects for mixed-reality environments

Anasol PEÑA-RIOS^{a,1}, Vic CALLAGHAN^{a,b}, Michael GARDNER^a and Mohammed J. ALHADDAD^b

^aDepartment of Computer Science, University of Essex, UK.

^bFaculty of Computing and Information Technology, King Abdulaziz University, KSA.

Abstract. These days technology enables people to collaborate on work, despite being separated by large physical distances. A variety of such systems have been developed to support organisations such as universities or companies. Most of these platforms are focused on conveying information rather than dealing with collaboration around physical activities that are common in product development or university laboratory activities, where, if such work exists, tend to be confined to the use of simulations. In this paper we introduce a system and associated set of techniques that enables teams of physically dispersed workers to collaborate on the construction of products that comprise both physical (hardware) and information (software) based objects in a so-called mixed-reality environment. The work aims to support dispersed development teams such as students, company R&D members or hobbyist (e.g. enabling the creation of virtual *hackerspaces*). As such the work focuses around the use of *Internet-of-Things* technologies to enable people to collectively build new products. In this work-in-progress paper we describe the implementation of *xReality objects* and their communication within an interreality system, extending our previous work towards the creation of a holistic option for enable geographically dispersed teams to collaborate on the construction of mixed hardware and software products.

Keywords. Mixed reality, dual reality, constructionism, virtual laboratory, virtual *hackerspace*, collaborative R&D, blended reality, xReality objects, interreality, human-machine interface (HMI), internet-of-things, tangible user interface (TUI).

Introduction

In previous papers [1] [2] we presented an innovative conceptual model for the creation of a mixed reality learning environment which aimed to enhance distance laboratory activities based on a constructionist perspective [3]. For these learning activities we proposed the use of physical and virtual objects to simulate real interaction with the laboratory equipment and to promote collaboration between students situated in different geographical locations.

In this work-in-progress paper we describe the first phase of implementation of our conceptual model, the *InterReality Portal* and generalise the concept beyond educational applications. Van Kokswijk [4] defined *interreality* as the user perception

¹ Corresponding Author: Anasol Peña-Ríos, School of Computer Science & Electronic Engineering, University of Essex, Wivenhoe Park, Colchester, CO4 3SQ, UK; E-mail: acpena@essex.ac.uk

of total integration between the physical and the virtual world, “*a hybrid total experience between reality and virtuality*”; a phenomenon now present in everyday activities such as watching TV, talking by phone with an individual not situated in the same physical space, chatting and sharing information through the Internet using mobile devices or even reading a book -if the reader is very interested on the plot-. As we can see living in two realities is something very common and the human brain manages to switch and blend two (or more!) realities at the same time. However, in these examples, the user is the one who blends both realities and make them work. The user’s ability to “switch context between real-local and virtual-distant environments and blend traces of one into the other in a socially unconscious manner (often seemingly simultaneously)” is defined as Blended Reality [5]. Still this mechanism can fail; individuals can get so immersed in the activities they are performing that they can be totally absorbed in one reality at a time, having a lack of presence in the other reality [6]. Lifton et-al. defined this behaviour as the “*vacancy problem*” which limits the capacity of user’s presence and engagement to a single reality at a time, as a consequence of user’s real immersion to the activity performed at that moment [7].

Dual reality attempts to create an integrated environment able to mirror and complement both, virtual and real worlds, in real time, avoiding the *vacancy problem*, using the combination of a ubiquitously networked sensor/actuator infrastructure and 3D virtual environments [8] performing a real-time data interchange process between the real world and the virtual world. This means that the environment does not stop on a point in between the reality-virtuality continuum [9], such as augmented virtuality (AV) and augmented reality (AR) interfaces which add a data layer to virtuality or reality respectively. Instead it transmits the data from the real world to the virtual world in real-time allowing the existence of the real object and a mirrored virtual representation of the same object, which ideally should be updated one from the other on a bidirectional process.

In [10] [11] we proposed the use of *xReality objects*, which are smart objects coupled to their virtual representation, updated and maintained in real time, to create this dual reality state in order to perform remote collaborative laboratory activities. Smart objects can be defined as “*autonomous physical/digital objects augmented with sensing, processing, and network capabilities*” which can interpret their local situation and status, and can communicate with other smart objects and interact with human users [12]. A key point to differentiate smart objects from *xReality objects* is that the digital representation of the latter emulates the shape, look and status of the physical object in a 3D environment, whereas the digital representation of a smart object is commonly a 2D graphic or table.

The collaborative laboratory activity proposed for our test bed is the creation of a computer science project which combines hardware and software modules to produce Internet-of-Things (IoT) applications emphasising computing fundamentals. Internet-of-Things (IoT) could be defined as “*a dynamic global network infrastructure with self-configuring capabilities based on standard and interoperable communication protocols where physical and virtual “things” have identities, physical attributes, and virtual personalities and use intelligent interfaces, and are seamlessly integrated into the information network*” [13].

In the research scenario proposed by us, the user creates mashups between virtual and real objects to produce a computer-science tangible deliverables, developing problem-solving skills by the correlation between concepts and real tasks (Problem-based Learning) [14]. Our original work focused on education where we found that most of the laboratory activities for distance learners were focused on simulations using software interfaces (virtual laboratories or eLabs) having minimum or no interaction with real equipment and, in most of the cases, performed using idealized data [15]. In addition, a great deal of research on virtual laboratory activities is focused on a single student, whereas real laboratory activities are usually performed as a group, considering collaboration between individuals on the resolution of a problem.

In a comparable way, product development in companies and even hobbyist's "do it yourself" (DIY) projects are based on collaborative work and problem-solving strategies, therefore the use of an interreality system such as the one proposed could help to support quick prototyping for companies or hobbyists on different geographical locations. A special scenario could be the use of our proposed interreality environment in *hackerspaces* or *makerspaces*. There is no standard definition for a *hackerspace*; several sources define them as "local spaces where hackers can meet, share knowledge and work on projects" [16]; "community-operated physical places, where people can meet and work on their projects" [17] or "a physical location with tools and diverse experts who can help collaborate on projects in a wide range of scales, but it connotes a philosophy of doing things with no particular preference to empirical or theoretical methods" [18]. However there is a common idea on these definitions: a *hackerspace* has a physical location for collaborative co-creative work. The use of an interreality system on *hackerspaces* could enhance participation of distance users on the creative process by using virtual collaboration through *xReality objects*. These ideas could also be used on other scenarios where collaborative co-creative work is needed for geographically dispersed users, such as product research and development, telework, etc.

In the following section of this work-in-progress paper we start by describing the conceptual model and architecture of our interreality system before moving on to discuss implementation and future work. The first phase of our research involves the use of a single *dual reality* state, the following phases will include the incorporation of a two or more users and the management of multiple *dual reality* states, mirroring two or more *xReality objects* on a single virtual environment in synchronous time.

1. Conceptual model

Figure 1 shows the conceptual model proposed for the use of two or more interreality systems to create coordinated multiple dual reality states. In this diagram an interreality system is formed by 3 components: a) the *physical world*, where the user and the *xReality object* are situated; b) the *virtual world*, where the real-world data will be reflected using the virtual object; and c) the *interreality portal*, a human-computer interface (HCI) which captures the data obtained in real-time by the *xReality object*, processes this data so it can be mirrored by its virtual object and thereby links both worlds.

The Context-awareness (CA) agent periodically requests information from the *xReality object* to identify any change on the object and gather data from the sensors. The Mixed Reality (MR) agent obtains the information collected by the CA agent and translates this as an updated state/action in the virtual object. When this process is replicated on a second interreality system, the Dual Reality agent (DR) manages the multiple dual reality states to synchronise the virtual object(s) and show a unified virtual representation following these predefined rules [2]:

- a) A change in any Virtual object of a given InterReality Portal results in identical changes to all subscribing InterReality portals.
- b) A change in an *xReality object* of a given InterReality Portal results in changes in the representation of the real device on all subscribing InterReality portals.

In any of these cases the *xReality object* executes a discovery service which allows the interreality system to get updates and reflect them on the virtual environment.

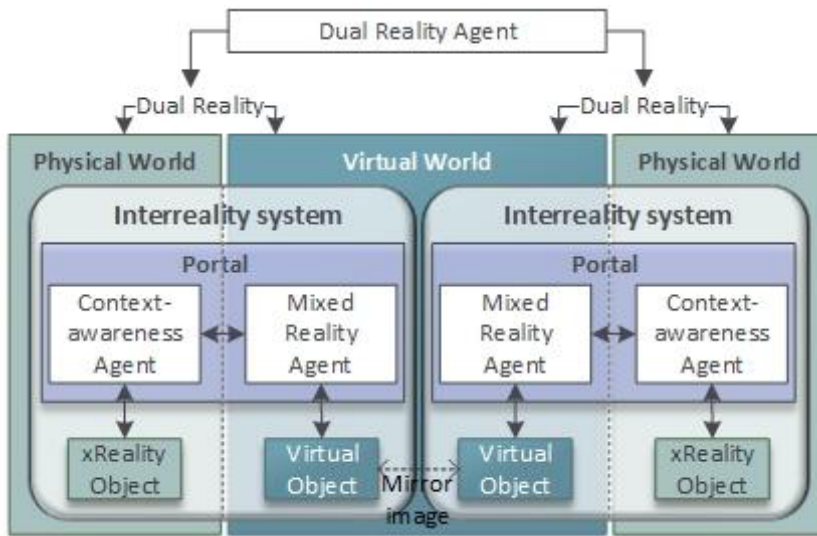

Figure 1. Conceptual model

1.1. *xReality object*

Figure 2 represents the conceptual construction of an *xReality object* and a virtual object. Following the ideas of smart objects on the Internet-of-Things (IoT), an *xReality object* has a unique ID, a list of available services (e.g. to get data or receive data) and in some cases rules (e.g. a certain object cannot work without fulfilling some preconditions). In a similar way each virtual object has a unique ID, one or more behaviours attached (e.g. the virtual object must behave as a solid object according to physical variables, such as weight, gravity, etc.) and rules similarly to the *xReality object*. The ID is the key to have the *xReality object* identified by the CA agent. Once identified the MR agent can access their predefined properties (rules, services and behaviours), to be used on the visualization layer, and update their status.

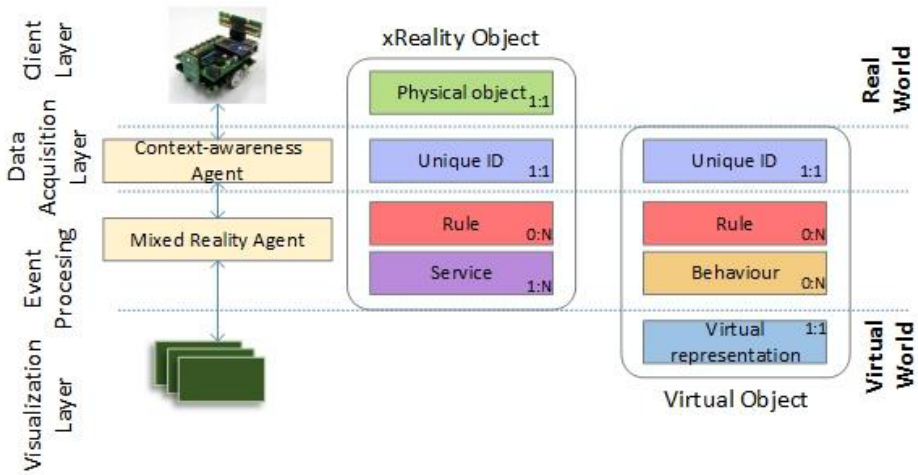

Figure 2. xReality Object Conceptual Model [10]

2. Implementation

Our implementation follows the main idea behind the tangible user interfaces (TUI) paradigm described by Fishkin [19], “a user uses their hands to manipulate some physical object(s) via physical gestures; a computer system detects this, alters its state, and gives feedback accordingly”. In our case, while the user manipulates the xReality object, the InterReality Portal detects the changes on the structure/services available and updates the state of the virtual object giving feedback to all the subscribing interreality portals. Figure 3 exemplifies the proposed architecture that communicates the xReality object with the InterReality portal. As previously stated in the introduction, an *xReality object* is usually implemented as a physical object with a unique id and predefined rules and behaviours (fig. 2). In our implementation the *xReality object* is formed by a group of interchangeable pluggable components, to create a mashup with a main component which identifies and integrates the others. This main component is the one that runs a discovery service to capture changes on the *xReality object* composition and to keep updated the virtual representation. These changes include modifications on the components connected to the main board and updates on the state of each component.

Guinard et al. [20] describe two types of mashups on the Web of Things (WoT): 1) physical-virtual mashups (or cyber-physical systems) and 2) physical-physical mashups. The first category refers to a combination of physical devices and different services available through and end-user interface, similar to Chin’s virtual appliances approach [21]. The second category refers to a physical user interface that uses real-world services without requiring an end-user interface, such as a computer or HTTP browser. The mashup created by our implementation could be considered physical-physical when connecting the xReality physical components, and physical-virtual when this components are coupled to their virtual representation.

The implementation of multiple dual reality states using the rules defined on section 1 is as follows:

- a) In case of a change of a virtual object of a given InterReality Portal, the MR agent will update and link the virtual objects maintaining the multiple dual reality status.
- b) In case of a change in the components of an xReality object of a given InterReality Portal, the CA agent detects which components are still available and the current status; if the object structure differs on the number or type of components available and the current structure is not replicated on the other xReality object, the InterReality Portal through the MR agent will block the use of the new component(s) on both xReality objects until both users decide if they want to keep the new structure or if they want to return to a previous state. Otherwise the MR agent will update and link the virtual objects maintaining the multiple dual reality status.

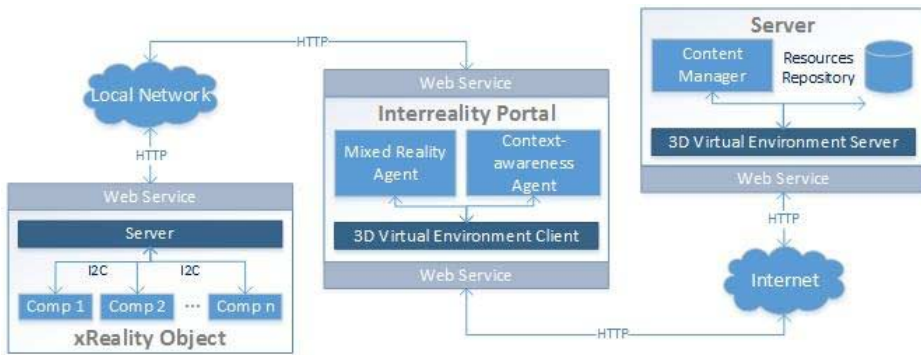

Figure 3. Proposed architecture

Communication between the *xReality object* and the 3D virtual environment (3D VE) client was implemented using a RESTful API. The Web of Things (WoT) proposes the use of web standards to integrate real-world things into the existing Web by changing real objects into RESTful resources that can be used directly over HTTP [20]. To do so, we decompose each component's into services that can be identified using URIs and use HTTP's main operations (GET, POST, PUT, DELETE) to interact with the object. Once the CA agent implemented on the 3D VE collects or sends this data, the MR agent matches an action to be performed on the visual representation.

2.1. *xReality object*

As previously mentioned, our implementation of an *xReality object* is formed by two different types of components: the main module, which detects other components and works as a hub to connect them to the interreality system; and a group of interchangeable pluggable components which comprises different sensors and actuators to allow the creation of diverse physical mashups.

The description of the *xReality object* implementation was defined as follows:

- a) *Main component*: The main component was implemented using a small low-cost computer, the Raspberry Pi² (RPi), which uses a linux-based operating system. The Raspberry Pi (RPi) is an open-source single board computer created for educational purposes; however, due to its cost, size and low power requirements has been used as a key component in embedded systems and implementations by hobbyist and creative hackers worldwide. We use a RPi as the main component on the xReality object, to identify other pluggable components and to send/receive information from the InterReality portal through a RESTful API. This latter was implemented using Bottle³, a python-based Web Server Gateway Interface (WSGI) micro web-framework distributed as a single file module and has no dependencies other than the Python Standard Library which makes simple and lightweight. Python⁴ is an open-source general-purpose programming language which promotes simplicity and code readability.
- b) *Pluggable components*: The components of the *xReality object* were implemented using a toolkit of diverse pluggable network-aware hardware boards which can be interconnected to create a variety of Internet-of-Things (IoT) projects such as mobile robots, mp3 players, heart monitors, etc. The Fortito's Buzz-Board Educational Toolkit⁵ allows the creation of quick prototypes by using combinations of modules plugged together. The discovery and communication of the boards with the main component (e.g. the RPi) was implemented using a python library for the Inter-Integrated Circuit bus (I²C). I²C is a multi-master serial single-ended computer bus created by Philips in 1982 for attaching low-speed peripherals [22] and allows the RPi to control a network of device chips using two general purpose I/O pins and a python library.

2.2. InterReality Portal

Finally, the implementation of the InterReality Portal was done using two main components:

- a) *An immersive environment*: To create the immersive environment we use Immersive Display Group's ImmersaStation⁶, a semi-spherical sectioned screen with a desk attached to simulate a natural position for performing learning activities, allowing a free-range of head movement without the need of any intrusive body instrumentation (e.g. special glasses).
- b) *A 3D virtual environment*: To visualise virtual representations of the *xReality objects* we developed a 3D GUI on Unity3D⁷, a cross-platform game engine used to create interactive 3D content which supports C# and JavaScript

² Raspberry Pi Foundation – <http://www.raspberrypi.org>

³ Bottle: Python Web Framework - <http://bottlepy.org/docs/dev/>

⁴ Python - <http://www.python.org/>

⁵ Fortito Ltd – <http://www.fortito.mx/en>

⁶ Immersive Display Group - <http://www.immersivedisplay.co.uk/immersastation.php>

⁷ Unity3D Game Engine - <http://www.unity3d.com/>

routines. The aim of this virtual reality GUI is to create a synthetic experience for the user due to the user’s sensory stimulation generated by the system [23]. It is based on client-server architecture, where a client is used on each immersive station to and the server manages and updates the multiple dual reality states (fig. 3).

Figure 4 illustrates all the parts on our implementation of a single Interreality system. The portal is formed by the immersive environment and the 3D GUI pictured on the upper part of the image. The 3D GUI shows the virtual representation of an *xReality object*: the main module and two pluggable secondary components with their metadata (ID and name). On the left corner, the image displays the implementation of the *xReality object*, using a RPi (main module) and two objects: Fortito’s *BuzzBerry*, which acts as a hub to connect different boards to RPi’s primary I²C channel, and *BuzzLed7*, a board with four 7-segment displays (secondary component). The hub (*BuzzBerry*) is just a bridge between the RPi and other objects; it cannot interpret data and it does not have any service/function available, therefore according to smart object’s definition presented at the introduction of this paper it does not qualify as a smart object and does not present any metadata on the 3D GUI. Through the 3D client interface the user can send an update to the *xReality object* and get a request for the current status of the Buzz-Led7 and the RPi. To do so, the 3D GUI uses the RPi IP (Internet Protocol) address in the local network and the RESTful API implemented to retrieve information as a JSON object. Then it parses the information retrieved and shows it on the client interface. Currently software components can be depicted as a list of available services for each BuzzBoard on the contextual menu, but the combination of the different components will allow also the mixture of their services to create a mixed reality mashup using software (services) and hardware (components).

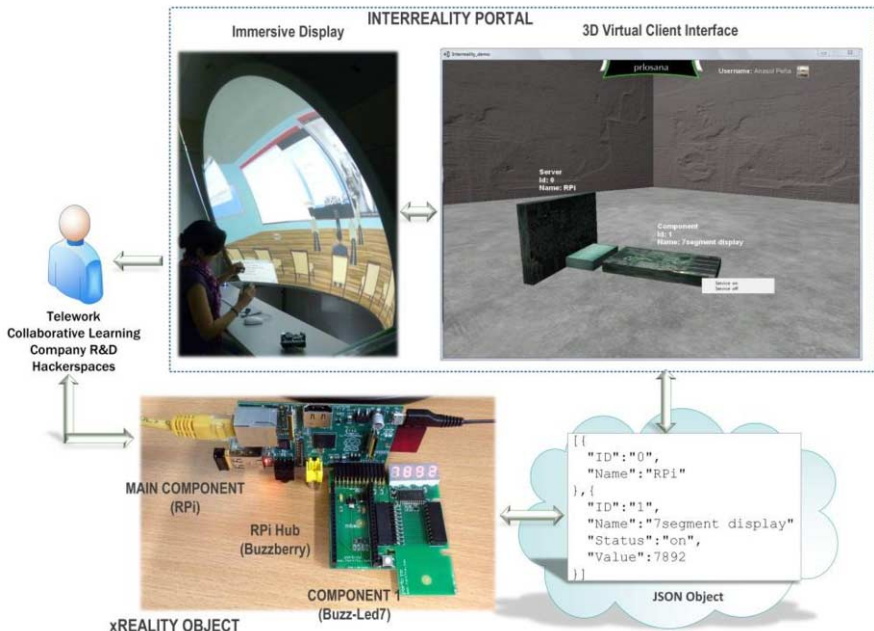

Figure 4. Interreality system

The first process on a session in the Interreality portal is the identification of all the actors/objects involved on the process of Blended Reality creation. To identify all the changes on the xReality object, a routine on the main component (RPi) periodically scans the I²C bus looking for changes on the pluggable components.

For user identification and validation we use OpenId⁸, an open standard created to consolidate user's digital identities on the Internet. By using this standard we eliminate the creation of the authentication layer sending this to third-party validation web services, furthermore enabling the possibility for our system to interact with other social sites. Once the user is authenticated by a third-party service, it is possible to match the user id, in this case an email address, to the user's profile on the system.

This implementation can be regarded as a type of tangible user interface (TUI). According to Ishii et al. a TUI is a user interface that "augment the real physical world by coupling digital information to everyday physical objects and environments" [24]. Brave et al. proposed 4 types of TUIs [25] based on: a) a graphical user interface (GUI), b) a GUI using Computer Supported Cooperative Work (CSCW) in real-time, c) a TUI, and d) a TUI using Computer Supported Cooperative Work (CSCW) in real-time. For our implementation we use both a GUI (a 3D virtual space) and a TUI (in the form of xReality objects). The first stage of our implementation is focused only on one environment but the following stages involve the use of CSCW in real-time.

Another point to consider is user's perceptual coupling of these tangible and intangible representations. As stated by Sears et al. to enhance perceptual coupling is essential to work on real-time on "the coincidence of inputs and output spaces (spatial continuity of tangible and intangible representations)" [26]. Currently intangible representation on our implementation focuses on visual simulation, through immersive hardware and software, and tangible representation is embodied on haptic simulation using *xReality objects*; however this does not limits the use of other type of stimuli such as aural or vocal on our future work.

Summary and future work

In this paper we briefly explained our previous work and the rationale behind our research which is to enable groups of geographically dispersed workers to collaborate on the construction of an Internet-of-Things system. Such groups might be drawn from sets on online learners (students), members of a company R&D team or hobbyists who are using this system to create a virtual *hackerspace*. In terms of the science we described the architectural model and implementation of the first stage of our mixed-reality learning environment using web standards and physical objects embodied on the mashup of Fortito's Buzzboards and the RPi. In particular we introduced the concepts and architectural design of an *xReality object* and showed how it is linked to a virtual representation within the Interreality Portal using a 3D engine. This work is part of a much larger project which aims to build and test such a system operating between continents so, in that respect, this paper describes components of that longer term aspiration, setting up the basis for our upcoming research. For the next phases we will

⁸ OpenId Foundation - <http://openid.net/>

explore the design and implementation of mixed reality laboratory activities managing a single dual reality state and we will extend our research to the management of multiple dual reality states adding a collaborative layer to the laboratory activity between two or more learners in different geographical locations. Our main contribution from this paper is the proposed *xReality object* architecture and implementation of our collaborative learning interreality environment.

This work can be interpreted from a number of different points of view. At the lowest level it can be regarded as a micro intelligent environment in which *xReality objects* (i.e. product component) can be coupled using a discovery service to create small stand-alone appliances. From another point of view there is the possibility to scale it up to an intermediate level through the interaction with virtual components enabling systems of interconnects appliances to be formed (so-called virtual appliances). The Final point of view is the construction of macro intelligent environment (i.e. interconnected and potentially geographical dispersed appliance) creating the intriguing possibility of implement a large scale network of Interreality portals connected on different locations.

Much work still needs to be done before answering the various research questions set out in this paper, such as the technical issues relating to the management and creation of blended reality; evaluating the perceptual coupling of tangible to intangible representations and the diverse aspects concerning the use of *xReality objects* in collaborative co-creative activities. In this respect we look forward to presenting further outcomes of this research, as our work progresses, in subsequent workshops and conferences.

Acknowledgments

We are pleased to acknowledge King Abdulaziz University, Saudi Arabia for their generous funding of this research project, including the provision of a PhD scholarship to the lead author. In addition, we wish to thank Immersive Displays UK Ltd. and Fortito Ltd. for their support. Finally we are pleased to acknowledge Dr. Jeannette Chin (Anglia Ruskin University) for her advice on the end-user programming virtual appliance aspects, and Malcolm Lear (Essex University) for technical support relating to BuzzBoard technology.

References

- [1] A. Peña-Ríos, V. Callaghan, M. Gardner and M. J. Alhaddad, "Towards the Next Generation of Learning Environments: An InterReality Learning Portal and Model," in *8th International Conference on Intelligent Environments 2012 (IE'12)*, Guanajuato, Mexico, 2012.
- [2] A. Peña-Ríos, V. Callaghan, M. Gardner and M. J. Alhaddad, "InterReality Portal: A mixed reality co-creative intelligent learning environment," in *1st Workshop on Future Intelligent Educational Environments (WOFIEE'12)*, Guanajuato, Mexico, 2012.
- [3] S. Papert and I. Harel, *Constructionism*, Ablex Publishing Corporation, 1991.
- [4] J. van Kokswijk, Hum@n: Telecoms and Internet as Interface to Interreality : a Search for Adaptive Technology and Defining Users, Bergboek, 2003.

- [5] S. A. Applin and M. Fischer, "A Cultural Perspective on Mixed , Dual and Blended Reality," in *IUI - Workshop on Location Awareness for Mixed and Dual Reality (LAMDa'11)*, Palo Alto California, USA, 2011.
- [6] J. Lifton, M. Laibowitz, D. Harry, N.-w. Gong, M. Manas and J. A. Paradiso, "Metaphor and Manifestation— Cross-Reality with Ubiquitous Sensor/ Actuator Networks," *IEEE Pervasive Computing*, vol. 8, no. 3, pp. 24-33, 2009.
- [7] J. Lifton and J. Paradiso, "Dual Reality: Merging the Real and Virtual," *Lecture Notes of the Institute for Computer Sciences, Social Informatics and Telecommunications Engineering*, vol. 33, no. 1, pp. 12-28, 2010.
- [8] J. A. Paradiso and J. A. Landay, "Cross- Reality Environments," *IEEE Pervasive Computing*, vol. 8, no. 3, pp. 14-15, 2009.
- [9] P. Milgram and F. Kishino, "A taxonomy of virtual reality displays," *IEICE TRANSACTIONS on Information and Systems*, Vols. E77-D, no. 12, pp. 1321-1329, 1994.
- [10] A. Peña-Rios, V. Callaghan, M. Gardner and M. Alhaddad, "Remote mixed reality collaborative laboratory activities: Learning activities within the InterReality Portal," in *The Intelligent Campus International Symposium (IC'12)*, Macau, 2012.
- [11] A. Peña-Rios, V. Callaghan, M. Gardner and M. J. Alhaddad, "End-user programming & deconstructionalism for collaborative mixed reality laboratory co-creative activities," in *2nd European Immersive Education Summit (EiED'12)*, Paris, 2012.
- [12] G. Kortuem, F. Kawsar, D. Fitton and V. Sundramoorthy, "Smart objects as building blocks for the Internet of things," *IEEE Internet Computing*, vol. 14, no. 1, pp. 44-51, 2010.
- [13] H. Sundmaeker, P. Guillemin, P. Friess and S. Woelfflé, Vision and Challenges for Realising the Internet of Things, Cluster of European Research Projects on the Internet of Things (CERP-IoT) - European Commission, 2010.
- [14] K. -. K. Ngeow and S. Yoon, "Learning to learn: preparing teachers and students for problem-based learning. ERIC Digest.," 2001. [Online]. Available: <http://www.ericdigests.org/2002-2/problem.htm>. [Accessed 03 2012].
- [15] Z. Nedic, J. Machotka and A. Nafalski, "Remote laboratories versus virtual and real laboratories," in *Frontiers in Education*, 2003.
- [16] E. Blankwater, *Hacking the field. An ethnographic and historical study of the Dutch hacker field*, Universiteit van Amsterdam, 2011.
- [17] "Hackerspaces," [Online]. Available: <http://hackerspaces.org/wiki/>. [Accessed 15 04 2013].
- [18] M. Altman, Interviewee, *Founding a Hackerspace: An Interactive Qualifying Project Report*. [Interview]. 2010.
- [19] K. P. Fishkin, "A taxonomy for and analysis of tangible interfaces. Personal and Ubiquitous Computing," vol. 8, no. 5, pp. 347-358, 2004.
- [20] D. Guinard and V. Trifa, "Towards the web of things: Web mashups for embedded devices.," in *GuinardIn Workshop on Mashups, Enterprise Mashups and Lightweight Composition on the Web (MEM 2009)*, in *proceedings of WWW (International World Wide Web Conferences)*, Madrid, 2009.
- [21] J. Chin, V. Callaghan and G. Clarke, "Soft-appliances : A vision for user created networked appliances in digital homes," *Journal of Ambient Intelligence and Smart Environments*, vol. 1, no. 1, pp. 69-75, 2009.
- [22] NXP Semiconductors, "NXP," [Online]. Available: http://www.nxp.com/documents/user_manual/UM10204.pdf. [Accessed 25 02 2013].
- [23] G. J. Kim, *Designing virtual reality systems: the structured approach.*, Springer, 2005.
- [24] H. Ishii and B. Ulmer, "Tangible bits: towards seamless interfaces between people, bits, and atoms," in *Conference on Human Factors in Computing Systems (CHI'97)*, Atlanta, 1997.
- [25] S. Brave, H. Ishii and A. Dahley, "Tangible Interfaces for Remote Collaboration and Communication," in *In Proceedings of the ACM conference on Computer Supported Cooperative Work (CSCW'98)*, 1998.
- [26] A. Sears and J. A. Jacko, *The human-computer interaction handbook: fundamentals, evolving technologies and emerging applications*, CRC Press, 2007.

An Internet-Connected World: Google's Platform Strategies to Network Industry

Chien-Ming TUNG^a and Hsuan-Yi WU^b

^{a,b} *Graduate Institute of Business Administration, National Taiwan University*

Abstract. In this Internet-connected world across the globe surrounded by mobile phones, social media, cloud computing and contents, these information resources are owned by the five big technology fiefs – Apple, Amazon, Facebook, Google, and Microsoft. In this study, we focus on Google's platform strategies on how to manage and utilize its platform to deliver information from core business to partners of its ecosystem (Government / Companies, Innovators, Advertisers / Consumers, Software / Application Developers, Media Companies / Individuals), based on the concepts of platform dominance, dynamic capabilities, cross-platform integration and cooperation. We aim to generate unique strategies to extend Google's business models and its mission "*to organize the world's information and make it universally accessible and useful*" for future Internet-connected world.

Keywords. Internet-connected, platform dominance, dynamic capability, cross-platform integration and cooperation

1. Internet Connected World

More recently, Internet-dominance has been the center of conversation at International CES (Consumer Electronics Show). In 2010, a Skype-enabled TV made a big impression on Samsung's Smart Life devices. In 2012, connected devices continued to be the central theme at CES; there were more than half of the devices from display, smart home appliances to medical devices. In the latest CES 2013, the new "killer apps" are that connect nudge households into a lifestyle of effortless interactivity of devices by Internet of electricity. The main change is that most connected devices are part of a limited ecosystem with only one or two devices and all will communicate back to a server in the cloud. The unity of standard for connectivity, software, and even the clouds where data might be stored or processed forms this ecosystem. For the coming 2014 CES¹, the topics still focus on the network of content delivery, always-on connections and social sharing. As every person and device gets connected across the globe further, every industry and country will be altered. When networked world is changing by mobile, social, cloud, content, and devices converged by above new services, how an enterprise offers sustainable business models and the social, cultural, technological innovation for the future of consumer services become the key issue.

As Google's chief executive for a decade until 2011, Eric E. Schmidt oversaw Google's ascent from a small California startup focused on helping computer users search the Internet to a global technology giant. On December 12, 2011, he delivered a

¹ Refer to 2014 International CES, Super Sessions. <http://www.cesweb.org/Conference-Program/SuperSessions.aspx>

speech at The Economic Club, “Boundless horizons for an Internet-connected world”². He said, “*Technology is at a point now where we’re seeing the emergence of a number of global-scale platforms that are impressive in their reach and the ability for them to change the world*”. As web search frontier, Google expands its role from information platform to Internet service provider. It has released a lot of new services that live inside other applications, without having a standalone interface to facilitate the adoption of new service. Google now has offices in more than 40 countries, including all three of North Korea's neighbors, Russia, South Korea and China, another country criticized for systematic Internet censorship. After being accused of complying with China’s strict Internet regulations, Google pulled its search business from the world’s largest Internet market in 2010 by redirecting traffic from mainland China to Hong Kong. After his unofficial visit to North Korea and told to the reporters at Beijing Capital International Airport on January 10, 2013, “*As the world becomes increasingly connected, their decision to be virtually isolated is very much going to affect their physical world, their economic growth and so forth, and it will make it harder for them to catch up economically*”³. It is to encourage the end of North Korea’s self-imposed isolation and allow its citizens to use the internet, and complete the Google’s popular satellite imagery product, Google Map, in the coming future. Especially, the major competitor Apple iOS6 Maps actually shows a few major cities in North Korea, whereas Google Maps does not.

In April, 2013, Schmidt and Jared Cohen, the director of Google Ideas and a former adviser to both secretaries of state Condoleezza Rice and Hillary Clinton, published their book “The New Digital Age”⁴, which explores how the ubiquity of the Internet will change society. Inspired by the book, the paper here is to analyze where our internet-connected world is headed and what it means for people, states, nations, and businesses by Google’s strategies in the future.

2. Google’s Ecosystem

Google began in January 1996 as a research project by Larry Page and Sergey Brin when they were both PhD students at Stanford University in California. The name “Google”, was originated from a misspelling of the word “googol”, the large number 10^{100} , which was picked to signify their search engine “BackRub”, which takes “*to organize the world’s information and make it universally accessible and useful.*” as their mission. Originally, Google was settled under the Stanford University with the domain names ‘google.stanford.edu’ and ‘z.stanford.edu’, registered on September 15, 1997 till company incorporated on September 4, 1998, and its initial public offering followed on August 19, 2004.

Rapid growth since incorporation was triggered a flurry of products, acquisitions, and partnerships that expanded its domain beyond the core web search engine. These included Gmail, Google Maps, Google Books, Google Finance, Google Docs, Google Calendar, Google Checkout, Google Apps, Google News, Google Wallet, and in late June 2011, Google soft-launched a social networking service called Google+. With

² Refer to The Economic Club, Speech 2011-2012. <http://www.economicclub.org/page.cfm/go/videos>.

³ Refer to The New York Times, “Visit by Google Chairman May Benefit North Korea” <http://www.nytimes.com/2013/01/11/world/asia/eric-schmidt-bill-richardson-north-korea.html?pagewanted=all>

⁴ The New Digital Age: Reshaping the Future of People, Nations and Business, Released on April 23, 2013, \$15.85 on Amazon.

these initiatives and acquisition of YouTube and Double Click, in May 2011, Google sites became the 1st web property to surpass 1 billion monthly unique visitors; in the contrast, Microsoft was the 2nd as 0.9 billion, followed by Facebook with 0.7 billion.⁵ Today, the size of the World Wide Web of Google's index is estimated average 46 billion pages⁶ and Google enjoys 83.85% market share (January 9, 2013) worldwide⁷.

Based on above product portfolio, Google extends and enhances broad mission and collection of innovations since its search-based advertising is a fantastically profitable product to cover for many unprofitable ones. To meet company's mission, Google has spent billions of dollars creating its internet-based operating platform and developing proprietary technology. A freeware web browser Google Chrome was released in December 11, 2008, and reaches worldwide top 1 browser (29.4%) in December, 2012⁸. Android, a Linux-based operating system for mobile operating system, released on September 23, 2008, got impressive 75% market share at Q3 2012 according to analyst firm IDC. On November 19, 2009, Google released Chrome OS as a competitor both directly to Microsoft Windows and indirectly the company's word processing and spreadsheet applications on cloud computing. Google's successive introduction of the popular Android and Google Chrome OS for client-based operating system for different markets, mobile and personal computing has been to support its internet-based strategies.

Besides, the investment in infrastructure allows the continuously improving specified service levels and response times, rapidly develop and roll out new services devising. The proprietary technology provides the design and evolution for infrastructure and strategy of platform integration. The open and customizable nature of Android operating system is currently used on laptops, netbooks, smartbooks, and smart TVs (Google TV). In addition, developing projects of smart glasses, wristwatches, headphones, car CD and DVD players, mirrors, portable media players and landlines are on-going. An upcoming videogames console Ouya is running on Android slated for release in March 2013. It appears that cross-platform compatibility under same OS creates the trend for Google. In 2011, new concept of "Android@Home" for home automation technology, a system for tying together home devices via Google-authored protocols and APIs, was demonstrated. The network is similar to ZigBee, a low-power wireless network used for short-range home automation. However, the network will be designed to allow for enough bandwidth to transfer video, an external security camera, and for further cloud services provider to bring Google products into customers' homes.

In this Internet-connected world, refer to Bala Iyer and Thomas H. Davenport (2008), Google's ecosystem can be cataloged into four key players shown below:

- (1) Content Provider: it refers to an organization or individual that creates information, educational or entertainment content for the Internet, CD-ROMs or other software-based products. A content provider may or may not provide the software used to access the material.
- (2) Consumer: 'Unique visitors' is a count of how many different people access a Web site. For example, if a user leaves and comes back to the site five times during the

⁵ Refer to comScore Data Mine, Google Reaches 1 Billion Global Visitors, June 22,2011. <http://www.comscoredata.com/2011/06/google-reaches-1-billion-global-visitors/>

⁶ Refer to website The size of the World Wide Web (The Internet), <http://www.worldwidewebsite.com/>

⁷ Refer to website Net market share, <http://www.netmarketshare.com/search-engine-market-share.aspx?qprid=4>

⁸ Refer to website W3Counter. <http://www.w3counter.com/trends>

measurement period, that person is counted as one unique visitor, but would count as five “user sessions”. Unique visitors are determined by the number of unique IP addresses on incoming requests that a site receives, but this can never be 100% accurate. Depending on configuration issues and type of ISP service, in some cases, one IP address can represent many users; in other cases, several IP addresses can be from the same user.

- (3) **Advertiser:** Online advertising, also known as online advertisement, internet marketing, online marketing or e-marketing, is the marketing and promotion of products or services over the Internet. Examples of online advertising include contextual ads on search engine results pages, banner ads, blogs, rich media ads, social network advertising, interstitial ads, online classified advertising, advertising networks, dynamic banner ads, cross-platform ads and e-mail marketing, including e-mail spam. Many of these types of ads are delivered by an ad server.
- (4) **Innovator:** Various web applications that is innovated and accessed by users over a network such as the Internet or an intranet. Web applications are popular due to the ubiquity of web browsers, and the convenience of using a web browser as a client, sometimes called a thin client. The ability to update and maintain web applications without distributing and installing software on potentially thousands of client computers is a key reason for their popularity, as is the inherent support for cross-platform compatibility.

Figure 1. Google’s Innovation Ecosystem (adapted from Iyer and Davenport 2008)

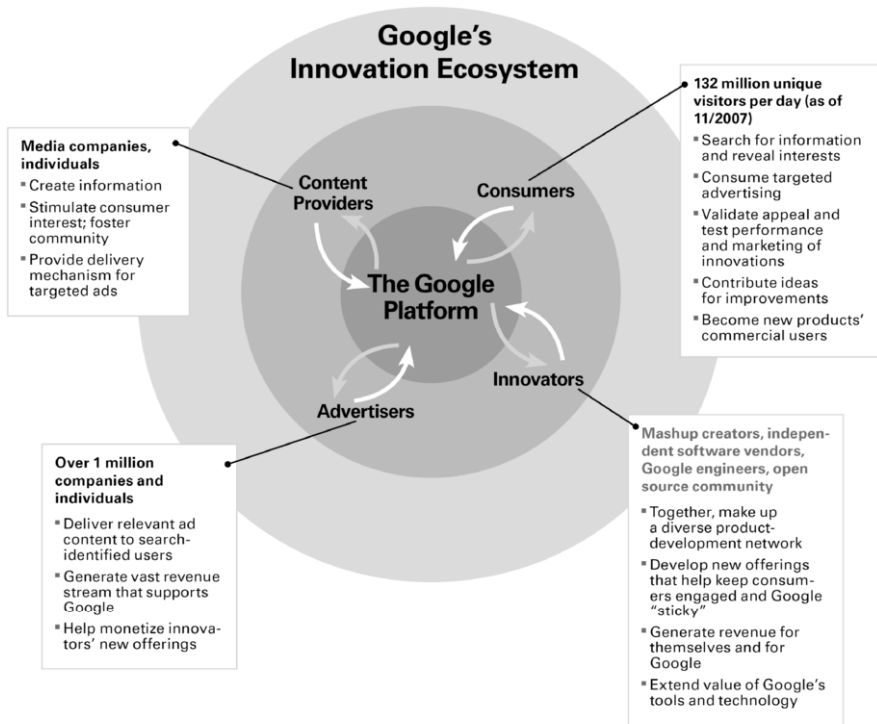

How does Google serve its community on the platform? Refer to 2013 Form 10-K, core businesses are in four areas:

- (1) **Search Engine:** A web search engine is software code that is designed to search for information on the World Wide Web. Some search engines also mine data available in databases or open directories, maintain real-time information by running an algorithm on a web crawler. Key providers are Google, Yahoo!, Bing, Baidu, Ask, AOL, etc.
- (2) **Social Networking:** a platform to build social networks or social relations among people who, for example, share interests, activities, backgrounds, or real-life connections. Online community services are sometimes considered as a social network service in a broader sense. Social networking sites allow users to share ideas, pictures, posts, activities, events, and interests with people in their network. Key providers are Facebook, YouTube, LinkedIn, Twitter, Google+, and MySpace.
- (3) **On-Line Shopping:** allows consumers to directly buy goods or services from a seller over the Internet using a web browser. Online goods and services such as streaming media, electronic books, software via B2B, B2C, and C2C channels. Key providers are Amazon, eBay, Taobao, etc.
- (4) **On-Line Advertising:** a form of promotion that uses the Internet for delivering marketing messages to attract customers. Online ads are delivered by an ad server, include contextual ads that appear on search engine results pages, banner ads, in text ads, Rich Media Ads, Social network advertising, online classified advertising, advertising networks and e-mail marketing, e-mail spam. Key Providers are Google, DoubleClick (Google), Yahoo!, MSN (Microsoft), AOL, Adbrite.

Here we summarize Figure 1 and Google's core business into a new model to explain how Google organizes the world's information and make it universally accessible and useful shown as Figure 2.

Figure 2. Google's Platform of information boundary

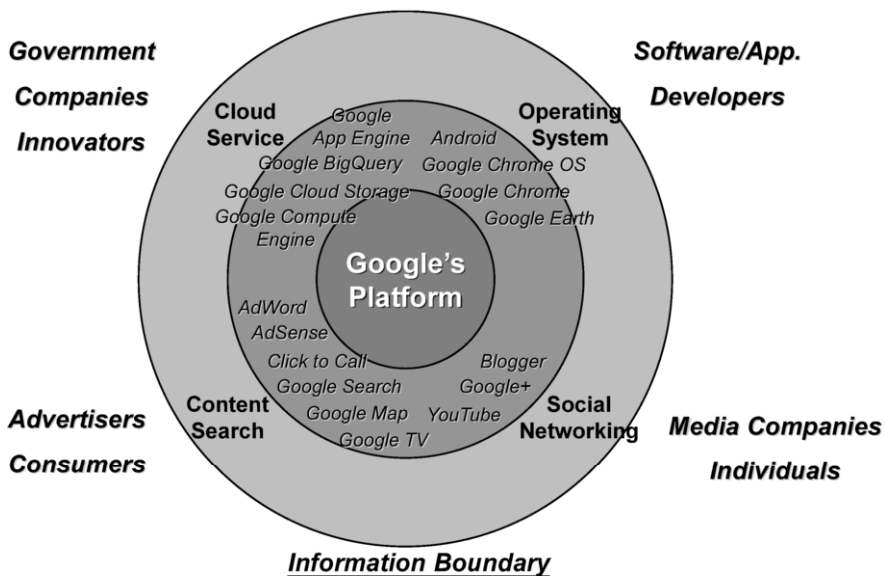

In this information ecosystem, even Google plays the role of a keystone—control components of dominance from its unique search technology, internet-based operating platform is working on multi-sided business by 4 actors, Content providers, consumers, advertisers, and innovators.

3. Literature Review

3.1. Platform Industry

Gawer and Cusumano (2008) described under the right circumstances, companies of any size can grow to become platform leaders. And particular business and technology decisions can help platform-leader wannabes achieve their goals. In the case study which pointed out that Google really won the platform leadership battle for Internet search on the business side by solving fundamental problems. An industry platform is a foundation technology or service that is essential for a broader, interdependent ecosystem of businesses. Eisenmann (2008) defined four types of firm strategies based on one/many platform provider and one/many platform sponsor, Proprietary, Licensing, Joint Venture, and Shared platforms. The firm strategies should be selected for different platform design.

Many mature networked markets are served by a single platform. Winner-take-all (WTA) dynamics are likely to prevail at the platform level when three conditions all hold:

- (1) Network Effects are Strong. Users will want access to all potential transaction partners. A sub-scale platform will be of little interest to them unless it provides the only way to reach certain partners.
- (2) Multi-Homing Costs are High. Users need a good reason to affiliate with multiple platforms.
- (3) Demand for Differentiated Features is Limited. If special features are limited, then users will converge on one platform. By contrast, if segments have unique needs that are intrinsically difficult or expensive to serve through a single platform, then rival platforms can survive.

3.2. Dynamic Capability

Eisenhardt and Martin (2000) concluded that dynamic capabilities are a set of specific and identifiable processes such as product development, strategic decision making, and alliancing. Google generates revenue primarily by delivering relevant, cost-effective online advertising. Businesses use AdWords & AdSense to promote their products and services with targeted advertising and enhance the user experience. Platform Dominance

Srinivasan and Venkatraman (2010) analyzed the network positions of platform complementors to explain the platform dominance. The impact of degree of links with complementors representing the number of complements is significant that platform dominance is positively influenced by support from a greater breadth of titles by complementors and lesser degree of overlap with other platforms. In this model, degree of linkage, variety of linkage, degree of overlap with other platforms and complementor dominance would all positively affect the target platform dominance.

Gawer (2007) studies Intel's strategy with complements and found Intel's entry decisions are shaped by no capabilities to enter all possible markets, and thus that it must encourage widespread entry despite the fact that potential entrants for the understanding of the dynamics of competition in complements form in shaping competition. Arya and Lin (2007) extend the resource-based view in a collaboration network by investigating how NPO collaboration outcomes, reflected through a joint consideration of monetary and nonmonetary dimensions, may be affected by

organizational characteristics, partner attributes, and network structures. For Google's social networking, a platform to build social networks or social relations by online community services to allow users to share ideas, pictures, posts, activities, events, and interests with people in their network. Key providers are Facebook, YouTube, LinkedIn, Twitter, Google+, and MySpace. They would be measured for this topic.

3.3. Cross-platform Integration and Cooperation

In Google's business model, cross-platform competition and operation exists in different industries.

Competition from different platforms: Google search engine service is not only challenged by Bing and Yahoo!, but broader than general as we normally think of them, Apple, Amazon, and Facebook are also used often.

(1) *Product Search:*

Google lacks market power in a critical segment of product search, Amazon in product search for comparison-shopping as a search engine competitor to Google.

(2) *Service Search:* Apple's Siri provides new voice search linked to answer. More than 25 billion apps can be downloaded from its App Store by the users from iPhone, iPad, and iPod touch devices worldwide for services.

(3) *Place Search:* search engines are evolving into places where users go for answers, and that Facebook is uniquely positioned to compete in that market: "when you think about it from that perspective, Facebook is pretty uniquely positioned to answer a lot of the questions that people have."

Cooperation from different platforms:

Google and Apple have a history of cooperation and rivalry. Apple iPhone's technological sophistication comes from a large amount of inputs by Apple's engineers and designers. The success is in part because of its utilization of Google's information technology, Google internet search, Google Maps, and YouTube installed. However, in August of 2005 when Google acquired Android Inc. and formed the Open Handset Alliance and concurrently announced Android as a mobile software platform in November of 2007, it directly threatened Apple's market. In 2012, Apple has made one final move to end support for Google Maps in their iOS platform. Application developers who worked with Google Maps' API must shift to Apple's Map Kit API when creating applications for the new iOS 6.

Google and Intel share the value of cooperation in the smartphone field. Intel announced new cooperation with Google in December 2011 to accelerate the Intel Corporation in the smartphone aspects of the business. Google Inc. said it will focus on the Atom chip for future versions of the Android operating system which is optimized with the appearance of a smart phone reference design. But for analysts, Intel's chips in the computer field are invincible, but smartphone makers use more of the ARM chip architecture. Although in recent years, Intel has repeatedly said that Atom for smartphone will go on sale, but ultimately anticlimactic.

4. A Framework for Platform Research

4.1. Platform Framework

We propose a framework for platform research shown as Figure 3 to examine the characteristics of network industry. In network industry, platform dominance, dynamic capability, and cross-platform integration/coopetition are three dominants.

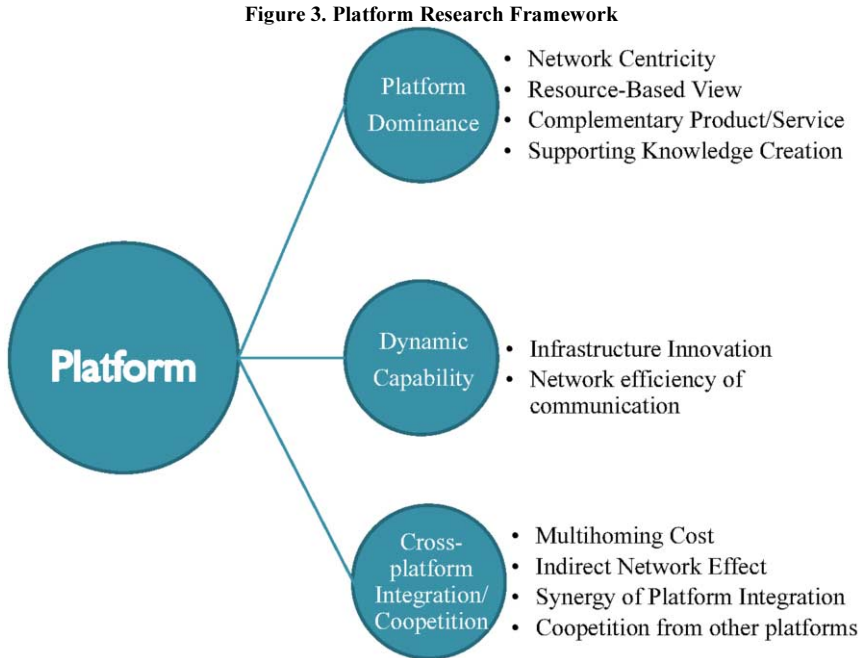

4.2. Analytical framework

By referring to “Catalyst Code”, we try to analyze Google’s business and integrated into the framework above.

Platform Dominance

(1) Network Centricity

To support Google’s core business of the different groups (user/developer, customer/advertiser) to interact, three major mediators for network centricity are :

- Brower : W3Counter indicated that Chrome became the leading browser globally in March 2013 with 30.3% market share. User could link to Chrome Web Store for web applications for Google Chrome or Google Apps.
- Chrome OS (for PC market) : A Linux-based operating system released on November, 2009, Chrome OS is viewed as a competitor to Microsoft Windows directly and office suit (word processing and spreadsheet applications) indirectly , the latter through Chrome OS's reliance on cloud computing.
- Android OS (for mobile market) : A Linux-based operating system designed primarily for touchscreen mobile devices such as smartphones and tablet computers. According to StatCounter on March 2013, Android(37.23%) is

topping than iOS (27.14%) and Windows Phone(1.19%). The operating system's success has made it a target for patent litigation as part of the so-called "smartphone wars" between technology companies.

(2) *Resourced-Based View*

- To exchange resources of tangible goods and intangible information, on Social Networking, the \$1.65 billion acquisition of YouTube (2006), put Google in the role of content host—storing materials on Google-owned servers, reaching 136 million videos in September 2012. Besides , Google provides Google+ the second largest social networking site in the world on November 2011, having passed Twitter in January 2013.
- On E-Marketplace : Google Play, the digital application distribution platform for Android and an online electronics store developed and maintained by Google. The service allows users to browse and download music, magazines, books, movies, television programs, and applications published through Google.

(3) *Complementary Product/Service*

In “2012 Corporate Highlights”, new potential product is on developing, such as,

- Google Play—an entirely cloud-based, digital entertainment destination with more than 700,000 apps and games plus music, movies and books that users can find, enjoy and share on the web and on their Android phone or tablet.
- Google Now—a predictive search feature that gets right information at the right time, such as to tell user the day’s weather before starting the day, how traffic to expect before leaving, or favorite team’s score while they’re playing – all automatically appearing throughout the day at the moment you need them.

(4) *Supporting Knowledge Creation*

- Knowledge Graph—introduced in 2012, enables the user to search for things, people or places that Google knows about – landmarks, celebrities, cities, sports teams, buildings, geographical features, movies, works of arts and more – and enhances Google Search by understanding the ambiguities in language and by better understanding a user’s query. In Linda A. Hill & Emily A. Stecher (2010) research, the continual innovation of Google’s infrastructure is imperative. R&D expense of total revenue occupies 13.5% of 2012 to make significant investments.
- Google lowered the online price from US \$4 per 1,000 map loads to 50cent per 1,000 map loads, and Maps API remains free for the vast majority of sites. Google eliminates the previous distinction between Styled Maps and regular unstyled maps. The same usage limits and pricing now apply to applications using Styled Maps and the default Google Maps style.

Dynamic Capabilities

(1) *Infrastructure Innovation*

- Around 2000, Google's search engine rose to prominence. The company achieved better results for many searches with an innovation called PageRank. This iterative algorithm ranks web pages based on the number and PageRank of other web sites and pages that link there, on the premise that good or desirable pages are linked to more than others.
- To support Google’s search engine service, the AdWords program is generating revenue by dynamic pricing tools : cost-per-click (CPC) advertising and cost-per-mille (CPM) advertising, and site-targeted advertising for text, banner, and rich-media ads. Pricing mechanism includes : Max CPC Bid (maximum cost-per-click bid); Quality Score : The ad's past performance Click-through rate (CTR), and Ad Rank = Max CPC bid × Quality Score.

(2) *Network efficiency of communication*

- Google subsidizes user side permanently, pricing platform goods and services free to attract more users but charge to advertiser's side. From 2012 Form 10-K Financial Tables of As % of Google Revenues, 37.3% of Google revenues, includes 25.1% traffic acquisition costs of advertising revenues related to AdSense arrangements program, distribution fee paid, and some content displayed on YouTube by penetration pricing practices.

Cross-Platform Integration/Cooperation(1) *Multi-homing Cost*

- To compete with Microsoft by minimizing transaction cost, browser(Chrome) and Linux-based OS(Chrome OS and Android) is free source code to developer by licensing, takes no transaction cost on Chrome Store or Google Play for applications.
- Pay customers to belong, in 2009, Google paid \$82 million to Apple iOS for the privilege. Over the years, Apple has gotten more revenue from Google as Microsoft has been pushing very hard and bidding to make Bing the default search engine. As Samsung is now the dominant manufacturer, the Apple-Google deal could peak soon. Google will watch closely how market shares change and could end the deal or lower its terms at the first opportunity.

(2) *Indirect Network Effect*

- Content provider : Google's YouTube introduces paid content subscriptions that some content producers will offer channels which consumers are willing to pay for — this subscription service helps anyone learn software, creative, and business skills to achieve their personal and professional goals. For Google Book announced in December 2004, American publishers and Google have come to terms over the company's ambitious book-digitizing project, these lawsuits let Google acknowledges the rights and interests of copyright-holders.
- Advertiser : The AdWords allows advertisers the option of enabling their ads to show on Google's partner networks. The "search network" includes AOL search, Ask.com, and Netscape show AdWords ads in response to user searches. AdSense allows publishers in the Google Network of content sites to serve automatic text, image, video, and rich media adverts that are targeted to site content and audience. Traffic acquisition costs related to AdSense and distribution arrangements of 2012 is \$10.96 billion, pays 25.1% revenue to Google Network Members and distribution partners.
- Innovator : Such as system manufacturers (Samsung, Acer,HTC, etc.) are willing to use free licensing fee Android and Chrome OS to enhance their product competitiveness. Individual developers invent and sell their paid product, music, software on Google store or Google Play without transaction fee. In Cloud Computing, Google is building ecosystem with technical partners.

(3) *Synergy of Platform Integration*

- Google's search technologies deliver relevant and useful search results in response to user queries, integrated with innovative Product Listing Ads, which include richer product information, such as product image, price, and merchant information, without requiring additional keywords or ad text.
- For social networking, the released of Google+ in 2011 with integration between Google+ and other Google properties, such as Gmail and YouTube. A user performs a signed-in search on Google, the user's results page may include Google+ content from people that the user is close to (or might be interested in

following). Relevant Google+ profiles and Google+ pages related to a specific topic or area of interest may also appear on a user's results page.

- In Near Field Communication (NFC) service, Google Wallet is a mobile payment system developed by Google on May 2011, that allows its users to store debit cards, credit cards, loyalty cards, and gift cards among other things, as well as redeeming sales promotions on their mobile phone. In Wireless Charging Technology (WCT), the advocacy group Power Matters Alliance (PMA) on April announced that it has recruited Samsung, HTC and LG to support its cause. The group has a long list of members, including AT&T, Google, Starbucks, Blackberry, NEC, Texas Instruments and ZTE.

(4) *Cooperation from other Platforms*

In the Federal Trade Commission (FTC) investigation in the final stage for monopolist of search market, they found the competitive ground may be Bing and Yahoo! at beginning. But the market is almost certainly broader than general search engines as we normally think of them, the major competitors include Apple, Amazon, and Facebook. Survey data from two consultancies that should give the antitrust authority pause:

- Forrester Research found that 1/3 online users started their product searches on Amazon compared to 13% who started their search from a traditional search site.
- comScore found that product searches on Amazon have grown 73% over the last year while shopping searches on Google have been flat.

It may not be natural to associate Amazon (an online retailer), Apple (a device maker), and Facebook (a social media site) with search, but in the technology industry, Google next competitive threat can come from anywhere. Monopoly and the kind of robust platform competition between Apple, Amazon, Google, and Facebook are mutually exclusive portraits of reality.

Differ from high market share of search engine service, Google's cloud service is also facing fierce competition from Amazon, IBM, Engine Yard, Heroku, Force.com, Microsoft Skytap, VMware, Rackspace, GoGrid, Enlight, HP etc, to attract more user/developer to its cloud platform, all free for trial/basic service but discrimination pricing for advance service. If any potential cooperation from other platforms ?

Alliance between Google and Apple : An history of cooperation and rivalry

On Macworld 2007, the iPhone was successful due in large part to Apple's engineers and designers, and utilization of Google's information technology : Google internet search, Google Maps, and YouTube installed. In many ways, Google was the first company to develop a second-party app for the iPhone; all of the other applications on the phone were developed internally by Apple. Given Apple's impressive hardware and Google's information architecture, a return to cooperation can provide users with more cutting-edge experiences such as the original Google Maps on the iPhone; it may seem commonplace now, but directly accessing a dynamic map on your smartphone was truly unique five years ago. However, significant headway needs to be made for such cooperation to ever again be possible.

Alliance between Google and Intel : the value of cooperation in the smartphone field

Intel announced new cooperation with Google on December 2011 to accelerate the Intel in the smart phone aspects. Google said it will focus on the Atom chip for future versions of the Android OS is optimized, the appearance of a smart phone reference design. Android joined on the Intel X86 architecture support is particularly important for Google TV product. For Google, Intel's most valuable is t software innovator,

thousands of software engineers engaged in the OS including Windows, including better able to run on its chips work to better compete with Microsoft and Apple.

5. Conclusion

Below are some suggestions for Google from platform perspectives for future internet-connected world:

5.1. Short-term focus

- Enlarging the OS market share of phone, TV, Pad, PC (Android and Chrome OS), competing OS monopoly of Microsoft.
- Cooperation with strategic 3C hardware manufacturers (e.g. Acer, Samsung, Motorola, HTC), controlling development software Know-How.

5.2. Middle-term focus

- The application and popularization of cloud services, complementary application software development
- Cooperation with the telecommunication systems providers to develop prototype of experimental products (Cloud Products) for B2C
- Based on competitive advantage of Google Map for Augmented Reality application of "Navigation HUD system" or "Street View Advertising"

5.3. Long-term focus

- 4th Industrial Revolution: Services of technology, especially for Experience Economy.
- Alliance of B2B and B2C industry in Cloud Computing with company vision. Cooperation alliance with such as Intel, Samsung, and maybe Apple.
- Persuade for unique Monopoly of information (e.g. Google Book), eliminate cross-platform completion from Amazon, Facebook, and regional content providers.

References

- [1] Abrams, S., Mark, G., 2007. Network-centricity: hindered by hierarchical anchors, CHIMIT '07 Proceedings of the 2007 symposium on Computer human interaction for the management of information technology, ISBN: 978-1-59593-635-6 doi>10.1145/1234772.1234782
- [2] Andrei Hagiu and David B. Yoffie, April 2009. What's Your Google Strategy? **Harvard Business Review**, Vol.87, Issue 4, pp.74-81.
- [3] Annabelle Gawer & Michael A. Cusumano, 2008. How Companies Become Platform Leaders. **MIT Sloan Management Review**, Vol.49, No.2, Ppp.28-35.
- [4] Arati Srinivasan and N. Venkatraman (2010) Indirect Network Effects and Platform Dominance in the Video Game Industry: A Network Perspective, **IEEE Transactions On Engineering Management**, Vol. 57, No. 4, November 2010
- [5] Benjamin Edelman & Thomas R. Eisenmann, 2010. Google Inc.. **Harvard Business School**, 9-910-036, Rev. February 12.

- [6] Bala Iyer and Thomas H. Davenport, April 2008. Reverse Engineering Google's Innovation Machine. **Harvard Business Review**, Vol.86, Issue 4, pp.58-68.
- [7] Arya, B. and Lin, Z., 2007, Understanding Collaboration Outcomes From an Extended Resource-Based View Perspective: The Roles of Organizational Characteristics, Partner Attributes, and Network Structures, **Journal of Management**, Vol. 33, No. 5, pp.697-723.
- [8] Diane Coutu, June 2007. We Googled You. **Harvard Business Review**, Vol. 85, Issue 6, pp.37-47.
- [9] David S. Evans & Richard Schmalensee "Catalyst Code: The Strategies Behind the World's Most Dynamic Companies", Harvard Business School Press; 1 edition (May 9, 2007).
- [10] Eric Schmidt, Jared Cohen, 2013. The New Digital Age: Reshaping the Future of People, Nations and Business. Knopf Published.
- [11] Gawer, A., 2007. Platform Owner Entry and Innovation in Complementary Markets: Evidence from Intel, **Journal of Economics & Management Strategy**, Vol. 16, No. 1, pp.1-34
- [12] Kathleen M. Eisenhardt and Jeffrey A. Martin, 2000. Dynamic Capabilities : What are they ? **Strategic Management Journal**, Vol.21, pp.1105-1121.
- [13] Linda A. Hill & Emily A. Stecher, 2010. System Infrastructure at Google (A) & (B). **Harvard Business School**, 9-410-110&111, Rev. August 4.
- [14] Richard A. D'aveni, 1994. Hyper-competition. **Free Press**, 1 edition (March 28, 1994).
- [15] Thomas R. Eisenmann, 2008. Managing Proprietary and Shared Platforms, **California Management Review**, Vol. 50, No.4, pp.31-53.

A DIY approach to the Internet of Things: A Smart Alarm Clock

Gary SCOTT^{a1} and Jeannette CHIN^b

^aAnglia Ruskin University

Cambridge, United Kingdom

gary.scott@student.anglia.ac.uk

^bComputing and Technology

Anglia Ruskin University

Cambridge, United Kingdom

jeannette.chin@anglia.ac.uk

Abstract. This paper explores how the recent development of low-cost System on a Chip (SoC) boards can be used by the Internet of Things (IoT) DIY community to assist the process of smart object innovation through the example of an intelligent alarm clock. The alarm clock will combine existing traffic and weather web services with local temperature sensor readings to provide a suitable alarm time for the user. Included is a brief review of currently available IoT components and state-of-the-art alarm clocks offering augmented features. Provided is a description and justification of both the hardware and software components of the alarm clock. CPU and memory resource testing demonstrate the computational suitability of the SoC device in the context of an intelligent alarm clock. User feedback regarding the features of the alarm clock provides suggestions for further development.

Keywords. Internet of Things, smart alarm clock, Raspberry Pi, System on a Chip, DIY, XBEE, smart objects

Introduction

Human beings possess strong drivers towards DIY which, aside from economic drivers, include using DIY as an outlet for creativity, taking control, diversification, societal resistance of excessive consumerism and globalisation and the simple desire of wanting to do it for oneself [1]. Recent trends in DIY electronics have provided the tools to enable mass creativity in the Internet of Things (was referred to as embedded-Internet devices back in early days [2]) and Smart Cities / Smart Homes.

Smart objects are a key IoT component and by definition are objects augmented with capabilities such as logic processing, information storage, sensing, real-world event actuation and network communication, made possible by small computers. Smart objects can communicate and interact with each other, their environments, the Internet and human beings [3]. An example of an existing smart object is Karotz [4], an Internet-enabled voice-activated smart rabbit which consumes feeds from a selection of

¹ Corresponding Author.

web services and reads the feeds aloud. Karotz also incorporates an RFID sensor to detect the presence of the RFID tags supplied with it.

This paper focuses on evaluating the use of state-of-the-art SoC technology for the purpose of smart object innovation in the form of a smart alarm clock. The device will be equipped with the ability to combine traffic and weather web service data with local temperature readings and automatically adjust the alarm time for the end user to reach a location at a predetermined time. The immediate envisaged benefits of such a device would be to relieve the burden of journey planning, whilst reducing time spent in traffic congestion and reaching their destination on time.

1. Available Technology for Smart Object Innovation

1.1. Microcontroller and System on a Chip (SoC) Boards

The emergence of low-cost and low-powered microcontroller and SoC boards, programmable using high level languages such as C# and Python has contributed towards IoT smart object innovation [5]. Examples of microcontroller boards are notably Arduino (programmed using Wiring), Gadgeteer and Netduino (both programmed using .Net framework). A SoC board is the equivalent of a pc running an operating system. An example of a SoC board is the Raspberry Pi, which runs its own version of Linux OS called Raspbian [6]. Python is the default programming language which is pre-installed in Raspbian, chosen for its ease to program and because it is an *interpreted language*, meaning it can be executed without having to be compiled [6]. A key benefit provided by SoC boards is the ability to run multiple processes on a tiny device suitable for incorporating into smart objects.

1.2. Smart Objects and their Interaction with the Real World

Smart objects need to be capable of both collecting data from their immediate environments and triggering real-world events. This is achieved using electronic sensors and actuators. Today there are a large number of low-cost analogue and digital electronic sensor types available to the DIY enthusiast, including light, colour, flex, force, motion, pressure, temperature, humidity, pulse, accelerometer and tilt [7]. Actuators are available in the form of LEDs, motors, audio output devices and electronic relays to turn devices on and off. Another key feature of a smart object is the ability to transmit and receive data over local networks or the Internet. A number of networking products designed to use low-energy protocols such as 6LoWPAN and ZigBee have become popular solutions to creating personal wireless sensor networks. Examples of such solutions are Digi International's XBEE and Cisco's XRF wireless radios. Their low power consumption makes these radios suitable for transmitting and receiving small packets of sensor and actuation data (unlike standard Wi-Fi radios, which are designed to transfer large multimedia and file data).

2. Review of Current State-of-the-Art Alarm Clocks

At the time this paper was written, no commercially available smart alarm clocks with functionality to dynamically adjust alarm times based on weather and traffic conditions had been released. A number of commercial alarm clocks, for example La Crosse WE-8115U-S Atomic Digital Clock [8], are available with augmented features such as indoor / outdoor temperature and humidity readings which are displayed on the clock LCD but no logic is performed with these readings.

2.1. Smart Alarm Clock Prototypes

The Dynamically Programmable Alarm Clock (DPAC), designed by students at Northeastern University in Boston, MA, is a self-setting alarm clock, which uses Google Calendar appointments to set alarm times and automatically adjusts them based on current traffic / weather conditions [9]. Web service requests and alarm time logic are performed by an external web service which feeds the alarm times to the clock.

The Rise alarm clock [10] is another product prototype which monitors and uses traffic conditions to calculate the optimal alarm time. It does not take weather data into account and requires connection to the Internet via a telephone socket.

2.2. Smart Phone Alarm Clock Applications

Smart Alarm Clock Pro ++ is an example of a smart alarm clock application which uses weather conditions to automatically adjust the alarm time. The application also incorporates RSS and weather feeds. The logic determining the alarm time is limited to weather forecasts only and does not take traffic conditions into consideration.

Although downloading a smart alarm application to a smart phone has the benefit of requiring no initial hardware outlay, the phone will require an appropriate stand and power supply to replicate the clock display of a dedicated alarm clock.

3. Alarm Clock Features

The key qualifying feature of the alarm clock as a smart object is the inclusion of logical processing of local sensor data and web services to determine the optimal alarm time for the end user to reach their predetermined location at the desired time. The magnitude of the alarm time adjustment is dependent on the severity of traffic incidents and weather forecast. Readings from the local temperature sensor are used to further adjust the alarm time to allow time for motorists to de-ice their vehicles if necessary. The local temperature sensor is included to improve the accuracy of readings specific to the user's local environment. Other features of the smart alarm clock include:

- Scrolling live news headlines sourced from a web service.
- Access to Internet radio feeds.
- Displays current traffic conditions for predetermined route.
- Displays local weather sourced from a web service.
- Hosts its own settings web page, accessible via a computer connected to the same local area network as the alarm clock.

4. Architectural Framework of Alarm Clock

4.1. Hardware for Alarm Clock

For the alarm clock to be able to perform the logic for the functions specified in section 3, a SoC board is necessary. The Raspberry Pi has been selected as it is readily available and has an active community of developers sharing projects and technical guidance [11]. As the Raspberry Pi is limited to obtaining its time from the network to which it is connected, the addition of a real time clock (RTC) module ensures the correct time is kept when Internet access is unavailable.

XBEE wireless radios provide communication of the temperature and humidity readings between the local sensor and the Raspberry Pi. The XBEE radios offer low-powered data transmission and a well-documented API [12]. A 20x4 character (HD44780) LCD [13] provides a visual display for the alarm clock data. Text strings longer than 20 characters can be scrolled on the screen. A control pad consisting of five input buttons connected via an 8-bit port expander chip (MCP23008) [14] to the Raspberry Pi's i2c interface provides an input user interface for the alarm clock. A suitable amplification solution and speaker will be connected to the Raspberry Pi's 3.5mm audio out jack to provide audio output for the alarm.

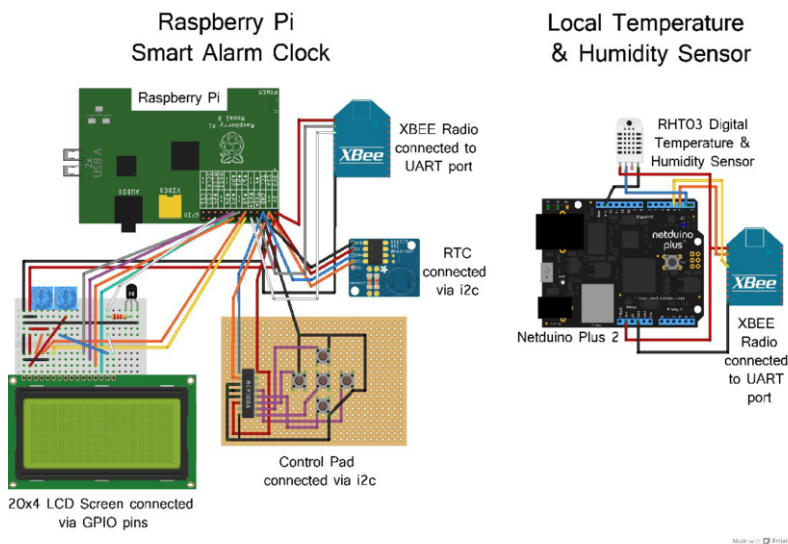

Figure 1. Connection Diagrams for Raspberry Pi Smart Alarm Clock and Local Temperature Sensor

4.2. Hardware for Local Temperature and Humidity Sensor

The RHT03 digital temperature and humidity sensor offers high precision and reliable readings [15]. For development purposes, a Netduino Plus 2 [16] microcontroller board has been selected to process the sensor readings and transfer them to the wireless XBEE module via the UART port. To conserve power further, a smaller microcontroller interface could replace the Netduino Plus 2 to enable the sensor to be battery powered.

4.3. Software and Web Services

The alarm clock software will be programmed in Python due to this language being pre-installed on the Raspbian OS along with its pre-existing support for the GPIO pins on the Raspberry Pi. The Netduino Plus 2 is programmed using the .NET framework and will be programmed in C# to collect and transmit the local sensor data.

The traffic web service used for alarm time calculations is Bing Maps REST services [17], which provides a simple RESTful interface for requesting traffic data along a route. Weather data is collected from the DataPoint API provided by the UK Met Office [18] which offers weather data in a simple format. XBEE communication is via the XBEE API to ensure correct transmission of sensor data via checksum error checking. Internet radio is streamed to the Raspberry Pi using the Music Player Daemon (MPD) and accessed via the mpc client [19].

4.4. Software Implementation of Alarm Clock

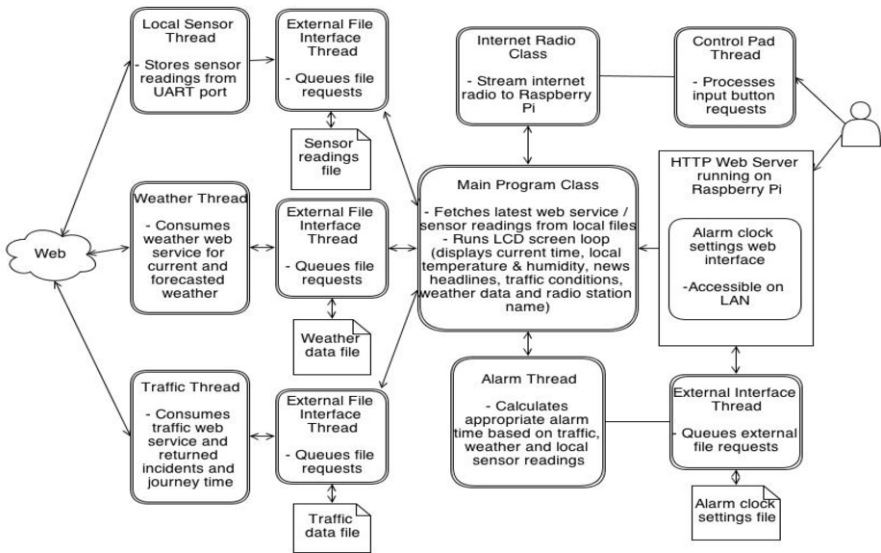

Figure 2. Diagram of Software Architectural Framework

5. Evaluation

Initial testing has demonstrated that the Raspberry Pi can capably run the smart alarm clock application, concurrently handling the web service and local sensor data requests alongside the LCD output, control pad input requests and its own web server running the settings interface. As reported by Linux’s process monitoring facility, ‘top’, the alarm clock utilises 25-27% CPU and 2.4% memory during standard operation. An additional 12% CPU and 2.5% memory is used whilst Internet radio is active (which spikes to 25% during station changes). This clearly leaves spare processing power and memory available for additional services to be added in future work.

A user trial comprising four IT MSc students at Anglia Ruskin University was set up with the objective of gaining feedback on the features of the alarm clock. Each

student was provided with an overview of the alarm clock before independently evaluating the usability of the LCD module and control pad.

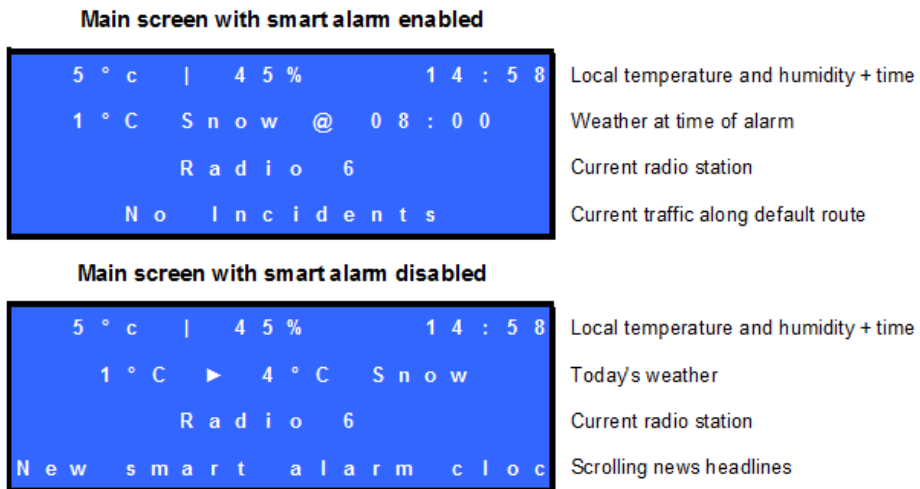

Figure 3. Alarm Clock Screen Layout on 20x4 LCD Module

User feedback includes the following suggestions:

- Incorporating a larger screen for greater clarity and addition of new services.
- Interfacing with Google Calendar to display appointments for the day ahead at the time of alarm.
- Providing a more intuitive method of configuring alarm settings via interfaces such as a larger screen, voice commands or a companion smartphone application.
- Porting the application to a smartphone app for use when away from home.
- The addition of social media feeds, for example Facebook and Twitter.

6. Conclusion and Future Work

As demonstrated by this work, incorporating SoC boards such as the Raspberry Pi into smart objects, specifically for the purpose of IoT innovation, greatly enhances the local processing capabilities of such objects and negates the usual power consumption overhead of a standard pc. The small physical dimensions of SoC boards enable smart objects to be used in locations where the use of a standard pc would be impractical. As the computational power of the Raspberry Pi is comparable to that of a 300MHz Pentium II PC [20], throughout the design and development phase of the alarm clock, data transfer was limited (where possible) to lightweight standards such as JSON and data storage was limited to local files instead of a dedicated database.

Although the Bing Maps service provides a simple RESTful interface for requesting traffic data along a route, one limitation of using this service is that delay times had to be interpreted from the delay descriptions provided by the service. Google

Maps combines live and historical traffic data to effectively calculate delay time [21] although at the time of writing this paper, a business licence is required to access this information via Google Maps API. The UK Highways Agency publishes its live traffic data in XML format via the Data.gov.uk website [22]. This is a comprehensive source of raw live traffic data but requires translating into geographical routes which is beyond the scope of this project.

In its current implementation, the local temperature and humidity sensor is constrained to transmitting directly to the alarm clock via the XBee wireless modules. Sensor readings could be published to the Internet to services such as Xively (formerly known as Cosm and Pachube) [23], which provides an API for other services to consume the readings. When considering a limited number of wireless sensors, this approach could be implemented by transmitting the sensor data directly to the Internet via the alarm clock's WiFi dongle. Whilst using the alarm clock to publish the data would introduce very little hardware resource overhead, adding further sensors may impact upon the performance of the alarm clock. One of the fundamental concepts of pervasive computing is creating environments saturated with sensors and computational abilities, for the benefit of the human occupants [24], thus, as smart objects start to interact with an increasing number of other local network nodes (other smart objects and local sensors/actuators), their computational overhead requirements will also increase. One solution would be to have all nodes transmitting to a dedicated local 'smart' gateway, which can be polled both internally and externally (via the Internet) for local node data. One such gateway that is currently under development is Ciseco's EVA Alpha board for the Raspberry Pi [25], which features multiple wireless sensor network protocol integration onto a single board. A Raspberry Pi then acts as the gateway between local networks and the Internet. The advantages of this model include increased network security via constraining the number of direct connections to the Internet, reduced resource overhead for constrained nodes, a higher level of interoperability between network protocols and the implementation of automated node discovery and subscription [26].

The components used to create the alarm clock are all widely documented by and freely available to the DIY community, enabling mass innovation potential towards the IoT field. By contrast with conventional product design, where the end user is the recipient of a predefined solution, the DIY approach to product innovation is the catalyst towards more personalised and heterogeneous end products [1].

References

- [1] Marc Roelands, Laurence Claeys, Marc Godon, Marjan Geerts, Mohamed Ali Feki, Lieven Trappeniers, Enabling the Masses to Become Creative in Smart Spaces, *Architecting the Internet of Things*, Springer-Verlag, Berlin Heidelberg (2011), 38, 42-43, 40.
- [2] Chin J, Callaghan V., Embedded-Internet Devices: A Means of Realising the Pervasive Computing Vision, Proceedings of the IADIS International Conference WWW/Internet 2003, ICWI 2003, Algarve Portugal, 2003
- [3] Irena Pletikosa Cvijikj, Florian Michahelles, The Toolkit Approach for End-user Participation in the Internet of Things, *Architecting the Internet of Things*, Springer-Verlag, Berlin Heidelberg (2011), 66.
- [4] Karotz: http://store.karotz.com/en_US/
- [5] Cuno Pfister, *Getting Started with the Internet of Things*, O'Reilly Media Inc., Sebastopol, CA, USA, 2011
- [6] Matt Richardson and Shawn Wallace, *Getting Started with Raspberry Pi*, O'Reilly Media Inc., Sebastopol, CA, USA, 2013

- [7] Robert Faludi, *Building Wireless Sensor Networks*, O'Reilly Media Inc., Sebastopol, CA, USA, 2011
- [8] La Crosse Technology: <http://www.lacrossetechnology.com/308-145/>
- [9] Eric Gaertner, DPAC – The Dynamically Programmable Alarm Clock: <http://egaertner.com/dpac/>
- [10] BBC News, Smart alarm clock lets you lie in: <http://news.bbc.co.uk/1/hi/technology/2269144.stm>
- [11] Raspberry Pi Forum: <http://www.raspberrypi.org/phpBB3/>
- [12] Digi International: http://ftp1.digi.com/support/documentation/90000982_B.pdf
- [13] Futurlec MCP23008 Datasheet: <https://www.futurlec.com/SFMicrochip/MCP23008.shtml>
- [14] HobbyTronics: <http://www.hobbytronics.co.uk/lcd-20-4-backlight-blue>
- [15] Maxdetect: <http://dlmnh9ip6v2uc.cloudfront.net/datasheets/Sensors/Weather/RHT03.pdf>
- [16] Netduino: <http://netduino.com/netduinoplus2/specs.htm>
- [17] MSDN Bing Maps REST Services: <http://msdn.microsoft.com/en-us/library/ff701713.aspx>
- [18] Met Office DataPoint: <http://www.metoffice.gov.uk/datapoint>
- [19] MPC Linux man page: <http://linux.die.net/man/1/mpc>
- [20] Raspberry Pi FAQs: <http://www.raspberrypi.org/faqs>
- [21] Google Maps: <http://support.google.com/maps/bin/answer.py?hl=en&answer=2549020>
- [22] Data.gov.uk: <http://data.gov.uk/dataset/live-traffic-information-from-the-highways-agency-road-network>
- [23] Xively.com: <https://xively.com/>
- [24] Satyanarayanan, M, Pervasive computing: vision and challenges, *Personal Communications*, vol. 8, Issue 4 (2001), 10-17
- [25] Kickstarter, EVE Alpha - Raspberry Pi wireless development hardware: <http://www.kickstarter.com/projects/ciseco/eve-alpha-raspberry-pi-wireless-development-hardwa>
- [26] Tools for the open source Internet of things: <http://iot-toolkit.com/>

Genetic Algorithms and Differential Evolution Algorithms Applied to Cyclic Instability Problem in Intelligent Environments with Nomadics Agents

Alejandro Sosa ^{a,1}, Víctor Zamudio, ^a Rosario Baltazar, ^a Vic Callaghan, ^b and Efrén Mezura ^c

^a*División de Estudios de Posgrado e Investigación, Instituto Tecnológico de León, Av. Tecnológico S/N, CP 37290 Guanajuato, México*

^b*School of Computer Science and Electronic Engineering, University of Essex, Wivenhoe Park CO4 3SQ, UK*

^c*Departamento de Inteligencia Artificial, Universidad Veracruzana, Sebastián Camacho #5, Centro, Xalapa, Veracruz, 91000, México.*

Abstract. In this paper the problem of cyclic instability in dynamic environments is presented. This cyclic instability is generated when binary rule-based nomadic agents (agents entering or leaving the environment) interact in complex ways, generating undesirable outputs for the final user. Our strategy is focused on minimizing this cyclic behaviour, using optimization algorithms, in particular Genetic and Differential Evolution Algorithms. These algorithms are applied to the Average Change Function. Different test instances were used to evaluate the performance of these algorithms. Additionally, statistical tests were applied to measure their performance.

Keywords. Nomadic Agents, Cyclic Instability, Genetic Algorithms, Differential Evolution

Introduction

Smart environments integrate the future vision of telecommunications, consumer electronics and computing. In a world of smart environments, the environment will be intended to assist people and provide customized services for monitoring, education, health, leisure, energy optimization, in a non-invasive way. Devices are getting smarter, smaller and cheaper, and they will be fully integrated to the environment, being able to communicate their states, and following the rules (learned or programmed) of the user. Cyclical instability is a fundamental problem characterized by the presence of unexpected oscillations caused by the interaction of the rules governing the agents involved [1] [2] [3] [4]. As mentioned before one of the challenges faced in intelligent environ-

¹Alejandro Sosa, Víctor Zamudio; E-mail:alejandro_sosa@ieee.org, vic.zamudio@ieee.org

ments is to prevent this cyclic instability; in our case we are considering the case of nomadic agent, in particular new agents joining the environment. New agents join the environment randomly, connecting and interacting with the agents already present in the system.

An Instability Prevention System (INPRES) has been successfully applied to the problem of cyclic instability [1] [2] [3] This strategy is based on analyzing the interaction network associated (a digraph, where the vertex are the agents, and the edges represent the dependencies of the rules of the agents), finding the cycles and locking an agent for each cycle. One of the main disadvantages of this strategy is the computational cost, as in big systems with high interconnectivity finding the cycles or loops can be computationally expensive. In the case of dynamic scenarios (where the topology of the network is changing, growing with time), INPRES is not the best option, as for each new change in the topology (in our case, a new agent joining the system) the interaction network should be analysed. Due to these problems, in this paper we are applying an optimization approach, comparing the performance of Differential Evolution and Genetic Algorithm. These algorithms aims to minimize the average change to the system required to prevent instability by locking a set of agents. By using this approach, we avoid finding the loops in the interaction network of the system. [2] [3] [4] [5].

1. Internet/Cloud of things

The Internet of Things (IoT) is an idea based on which a layer of digital connectivity to existing things, where "things" refers to all kinds of everyday objects, and even their components. This idea is expected to bring benefits in the short term, with application such as: mobile phones that open doors, sensors detecting leaks in pipes, billboards changing their ads according to the consumer profile of people passing through the street, small sensors measuring the temperature of a room or the traffic on the streets, and security cameras watching over the safety, and subway panels indicating the time remaining until the arrival of the next train[6].

Internet of Things is the kind of ubiquitous society where all people and all objects will be connected, and they will be identified and will be found. Everything will be connected to each other and exchange of information between objects and devices will become reality. In this world all objects and parts would be recorded, making it practically impossible for an object to be lost[7] [8].

One of the problems facing these interactions are the instabilities that may be generated between the devices, generating undesirable behavior in the intelligent environment. In this paper we analyze this problem (considering nomadic agents leaving the environment) and propose a solution based on optimization algorithms (GA and DE).

2. Problem in Cases Real

In recent years it has been found a numbers of cases showing unwanted cyclic behaviour, for example Robotics and manufacture, operating systems, telephony and emails [1] that have unwanted behavior as is the case of the Toyota Prius 2010 car which had faults

in the braking system [9], however, by the complexity of the system and the number of agents involved is extremely difficult to locate the agents that cause unwanted behavior.

Another problem caused by instability cyclic intelligent environments are, for example, in telephony, since it was not possible to have many devices connected together [1], another reported instability occurs with the software agent in this case by sending an email list because some are forming loops and causing instabilities in the system. Since it is very difficult to find when an occur oscillation strategies have been proposed to find the probability of occurrence of this instability, the probability of finding such instability can be calculated with:

$$P_{oscillations} = \frac{G(c, S_0)}{\prod_{i=1}^N \frac{2^{k_i} N!}{(n-k_i)!}} \quad (1)$$

where N is the number of nodes and k_i is the connectividad of node n . The number of sistem with oscillations, denoted by the function G depends on the cycles, denoted by c and the initial conditions denoted by S_0 . The demonstration can be seen in [1].

3. Differential Evolution

Differential Evolution (DE) [10] [11] is an algorithm developed by Rainer Storn and Kenneth Price for continuous space optimization, applied to solving complex problems. Differential Evolution has a population of candidate solutions, which recombine and mutate to produce new individuals to be elected according to the value of the function performance. Differential Evolution is a parallel direct search method which utilizes NP D-dimensional parameter vectors

$$x_{i,G}, i = 1, 2, \dots, NP \quad (2)$$

as a population for each generation G . NP does not change during the minimization process. The initial vector population is chosen randomly and should cover the entire parameter space. As a rule, we will assume a uniform distribution of probability for all random decisions unless otherwise stated. In case that a preliminary solution is available, the initial population might be generated by adding normally distributed random deviations to the nominal solution $x_{nom,0}$. DE generates new parameter vectors by adding the weighted difference between two population vectors to a third vector. Let this operation be called mutation. The mutated vectors parameters are then mixed with the parameters of another predetermined vector, the target vector, to yield the so-called trial vector. If the trial vector yields a lower cost function value than the target vector, the trial vector replaces the target vector in the following generation. This last operation is called selection. Each population vector has to serve once as the target vector so that NP competitions take place in one generation [12]. More specifically DEs basic strategy can be described as follows:

- Initialization: an initial population is generated randomly with a distribution uniform [12].

- Mutation: randomly select three vectors that are different, subtract two of them and the differences are applied weight given to them by a factor and finally add the difference to the third vector difference [13].
- Recombination: Recombination is performed, taking each of the individuals in the population as the primary parent and other parents are randomly selected three generating a son. If the child has generated a value of the objective function better than the primary parent, then replaces it [12].
- Selection: All vectors are selected once as primary parent without depending on the objective function, checks whether the selected parent is better than their child preserved generated this otherwise its value is replaced by the child [13].

3.1. Binary Differential Evolution

The binary DE (binDE)[14] borrows concepts from the binary particle swarm optimizer (binPSO), developed by Kenedy and Eberhart, in similar way, the binDE uses the floating-point DE individuals to determine a probability for each component. These probabilities are he used to generate a bitstring solution form the floating-point vector. This bitstring is used by the fitness function to determine its quality. The resulting fitness is then associated with the floating point representation of the individual. Let $x_i(t)$ represent a DE indivua, with aech $x_{ij}(t)(j=1,,n_x$, where n_x is the dimension of the binary-valued problem) a floating-point number. Then, the corresponding bitstring solution, $y_i(t)$, is calculate using:

$$y_{ij}(t) = \begin{cases} 1 & \text{if } U(0,1) < f(x_{ij}(t)) \\ 0 & \text{otherwise} \end{cases} \tag{3}$$

Where f is the sigmoid function

$$f(x) = \frac{1}{1 + e^{-x}} \tag{4}$$

The fitness of the individual $x_i(t)$ is the simply the fitness obtained using the binary representation $y_i(t)$.

Algorithm 1 Binary Differential Evolution Algorithm.

- 1: Initialize a population and set control parameter values:
 - 2: **Repeat**
 - 3: Select parent $x_i(t)$
 - 4: Select individuals for reproduction.
 - 5: Produce one offspring $x'(t)$
 - 6: $y_i(t)$ =generated bitsting form $x_i(t)$.
 - 7: $y'_i(t)$ =generates bitsting form $x'_i(t)$.
 - 8: **if** $f(y'_i(t))$ is better than $f(y_i(t))$ **then**
 - 9: Replace parent $x_i(t)$ with offspring $x'_i(t)$
 - 10: **else**
 - 11: Retain parent
 - 12: **end if**
 - 13: **Until** a convergence criterion is satisfied
-

4. Genetic Algorithm

Genetic Algorithm (GA) [15] is a search technique proposed by John Holland based on the theory of evolution by Darwin [15] [16][17]. This technique is based on the selection mechanisms that nature uses, according to which the fittest individuals in a population are those who survive, to adapt more easily to changes in their environment.

A fairly comprehensive definition of a Genetic Algorithm is proposed by John Koza [18]: It is a highly parallel mathematical algorithm that transforms a set of individual mathematical objects with respect to time using operations patterned according to the Darwinian principle of reproduction and survival of the fittest and after naturally have arisen from a series of genetic operations from which highlights the sexual recombination. Each of these mathematical objects is usually a string of characters (letters or numbers) of fixed length that fits the model of chains of chromosomes and is associated with a certain mathematical function that reflects their ability.

The GA seeks solutions in the space of a function through simple evolution. In general, the individual fitness of a population tends to reproduce and survive to the next generation, thus improving the next generation. Either way, inferior individuals can, with a certain probability, survive and reproduce. In Algorithm 3, a genetic algorithm is presented in a summary form [16].

Algorithm 2 Algorithm Genetic

```

1: Data: t (population size), G (maximum allowed function evaluations).
2: Result: Best Individual (Best Individual of last population).
3: P ← Initialize-population(t) Generate (randomly) an initial population
4: Evaluate(P) Calculate the fitness of each individual
5:
6: for g = 1 to G do
7:   P ← Select(P) Choose the best individuals in the population and pass them to the next generation
8:   P' ← Select(P) Choose the best individuals in the population and pass them to the next generation
9:   P' ← Mutation(P') Mutate one individual of population randomly chosen
10:  Evaluate (P') Calculate the fitness of each individual of new population
11:  P ← (P') Replace the old population with new population
12: end for

```

5. Using Optimization Algorithms to Solve the Problem of Cyclic Instability

In order to solve the problem of cyclic instability using optimization algorithms we need to minimize the amplitude of the oscillations. In the best-case scenario this would result in a stable system. Additionally we are interested on affecting the fewest number of agents (agents locked).

In order to measure the oscillatory behaviour of the system, two functions have been reported in the literature: Average Cumulative Oscillation (ACO)[16] and Average Change of the System (ACS)[19].

In this paper we use the Average Change of the System (ACS) function, which has been reported to be more accuracy to measure cyclic instability [19].

$$O = \frac{\sum_{i=1}^{n-1} x_i}{n-1} \begin{cases} 1 & \text{si } S_i \neq S_{i+1} \\ 0 & \text{en otro caso} \end{cases} \tag{5}$$

O: average change in system.

n : number of generations of scenario to test (total time of test).

with $S(t)$ being the state of the system in time t and $S(t + 1)$ being the state of system in time $t + 1$.

In the case of a stable system, this equation will show a flat line. Due to the previous, it is possible to use them as objective functions in a minimization algorithm.

6. Test Instance

Experiments were performed using test instance with following characteristics: they start with a 2x2 matrix of agents which was subsequently increased in size, ending with a 30x30 matrix of agents. In Figure 2 we can see the incidence matrix, increasing its size (as an example) from 2x2 to 4x4. Incoming agents were added at different times to the existing system, increasing the interaction network of the system.

The objective function is the weighted average of changes in the system which evaluates and retains the states of the agents that have fewer oscillations. It is intended that the system does not oscillate, affecting the system as little as possible, to ensure that it keep its own integrity and functionality to the end user.

A scenario where the system is no longer evolving shown in Figure 1, using the same topology and without applying any technique to minimize oscillations in the system.

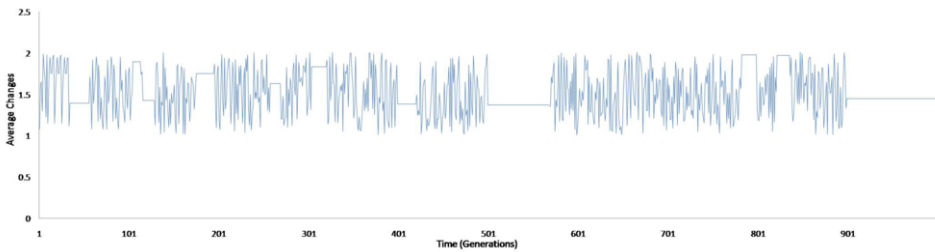

Figure 1. Graph Instability

0	0
1	0

0	0	1
1	0	0
1	1	0

0	0	1	0
1	0	0	0
1	1	0	1
1	0	0	0

Figure 2. Matrix of agents

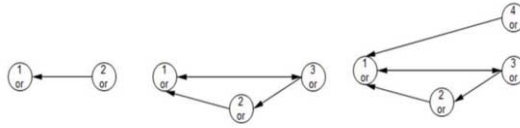

Figure 3. Graph of Agents associated to Figure 2.

In our case we will use the incidence matrix to represent of the digraph and manage the list of incidence, with the restriction that the main diagonal contains only 0's, in order to prevent the formation of loops on the same node.

As we mention before, we begin with a system with 2 agents (ie a 2x2 matrix), which will be increased randomly (as shown in Figure 2 and 3), ending with 30 agents, ie a 30x30 matrix (see Figure 4).

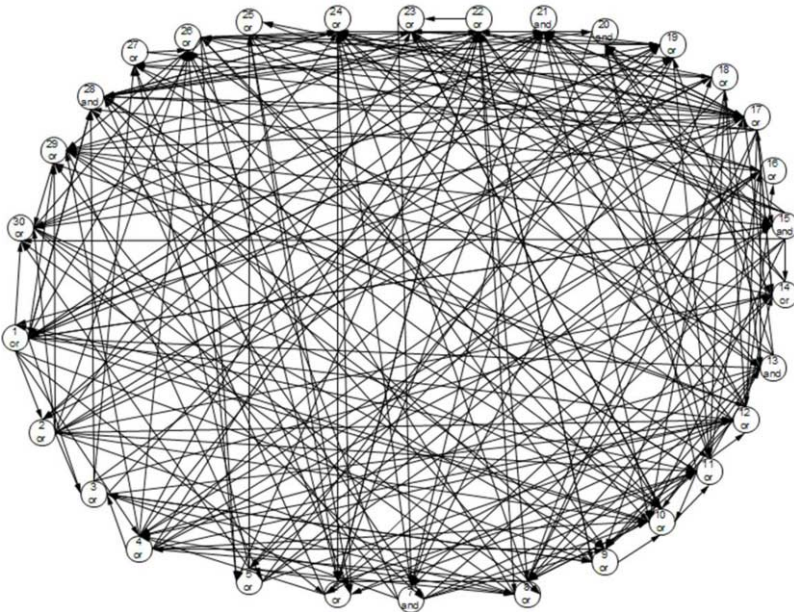

Figure 4. Digraph with 30 agents, associated to a 30x30 matrix.

To generate the test instance we used the following parameters

Parameters	Values
% of Connectivity	30
% of AND gate	40
% of Agents Locking	30
Dimension	30
Lifecycle	100

Table 1. of parameters

7. Experimental Result.

For the test performed with DE and AG for test instances we used the parameters shown in Tables 2 and 3.

Parameters	Values
# Particles	30
W	1
C1	0.4
C2	0.6
Function Call	1000

Table 2. Parameters of PSO algorithm

Parameters	Values
# Particles	30
% of Elitism	55
% of Cross	35
% of Mute	29
Function Call	1000

Table 3. Parameters of GA

The results are shown in Table 4 and Figure 5 which allows say the dynamic intelligent ambient can be stabilized over a given period provided. From these results it can be seen that cyclic instability arising from dynamic environments (where the interaction network is randomly increased with time) can be stabilized successfully using the GA and DE algorithms.

	Median	Best
AG	1.01011339	1.01011339
DE	1.00250249	1.00250249

Table 4. Result

The above results were subjected to nonparametric signed ranks Wilcoxon test [20] to analyze the identity statistics regarding the results of the calculation of the average change in the system of algorithms, from which were obtained $T + = 437$, $T = 27$, with $T0 = 109$ for a sampling of 30 test with a significance level of 0.01. The results indicate that there is enough statistical evidence to establish which algorithm shows better performance; in our case Differential Evolution has better results.

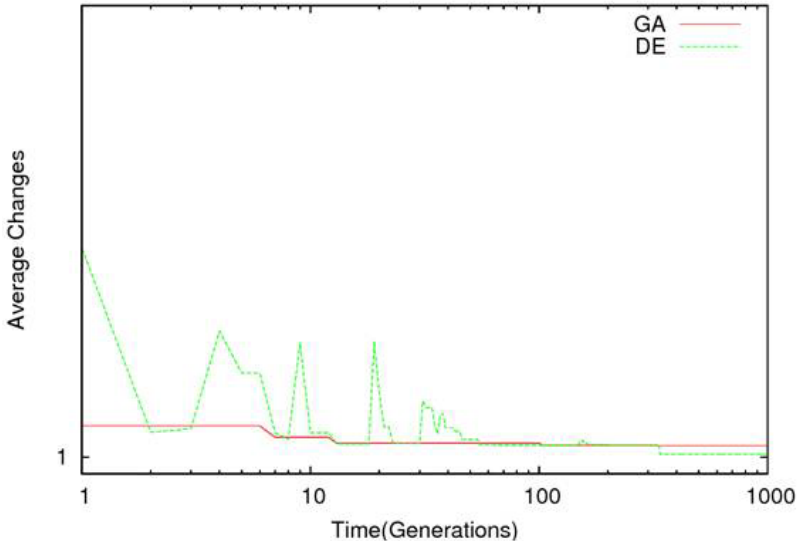

Figure 5. Graph Stability

8. Conclusions

In this paper we analysed the problem of cyclic instability with nomadic agents. In this particular case we are considering nomadic agents joining the environment, and interacting with those already present in the system. Two algorithms were considered: Differential Evolution and Genetic Algorithms. These algorithms were applied to the Average Change Function, which measured the number of changes in the state of the system in a given unit of time. The instability generated in these dynamic scenarios was successfully controlled using these algorithms. Using the Wilcoxon test (and due the fact there was enough statistical evidence) it was found that Differential Evolution algorithm had a better performance controlling these oscillations. These results are preliminary, but show very promising results. At the moment we are working on more complex test instances, including agents leaving the system (ie matrixes growing and shrinking), and a monitoring system to optimize the use of our strategy. We hope to report our result in future conferences.

References

- [1] V. M. Zamudio, *Understanding and Preventing Periodic Behavior in Ambient Intelligence*. PhD thesis, University of Essex, Oct. 2009.
- [2] V. Callaghan and V. Zamudio, “Facilitating the Ambient Intelligent Vision: A Theorem, Representation and Solution for Instability in Rule-Based Multi-Agent Systems,” *Special Section on Agent Based System Challenges for Ubiquitous and Pervasive Computing. International Transactions on System Science and Applications*, vol. 4, May 2008.

- [3] V. Callaghan and V. Zamudio, "Understanding and Avoiding Interaction Based Instability in Pervasive Computing Environments," *International Journal of pervasive Computing and Communications*, vol. 5, pp. 163–186, 2009.
- [4] V. Zamudio, R. Baltazar, and M. Casillas, "c-INPRES: Coupling Analysis Towards Locking Optimization in Ambient Intelligence," *The 6th International Conference on Intelligent Environments IE10*, July 2010.
- [5] A. Egerton, V. Zamudio, V. Callaghan, and G. Clarke, "Instability and Irrationality: Destructive and Constructive Services within Intelligent Environments," *Essex University: Southend-on-Sea, UK*, 2009.
- [6] D. Ucklemann, M. Harrison, and F. Michelles, eds., *Architecting the Internet of Things*. springer-verlag berlin heidelberg ed., 2011.
- [7] F. Mattern and C. Floerkemeier, "From active data management to event-based systems and more," ch. From the internet of computers to the internet of things, pp. 242–259, Berlin, Heidelberg: Springer-Verlag, 2010.
- [8] J. Gubbi, R. Buyya, S. Marusic, and M. Palaniswami, "Internet of Things (IoT): A Vision, Architectural Elements, and Future Directions," *CoRR*, pp. –1–1, 2012.
- [9] "oyota. Prius, 2010. URL <http://www.toyota.com/espanol/recall/abs.html>."
- [10] R. Storn and K. Price, "Differential evolution - a fast and efficient heuristic for global optimization over continuous spaces," *Journal of Global Optimization*, 1997.
- [11] S. Rainer and K. Price, "Differential evolution -a simple and efficient adaptative scheme for global optimization over continuous space," *International Computer Science*, Mar. 1995.
- [12] L. V. Santana Quintero and C. A. Coello Coello, "Un Algoritmo Basado en Evolución Diferencial para Resolver Problemas Multiobjetivo," Master's thesis, IPN, 204.
- [13] R. d. C. Gomez Ramon, "Estudio empírico de variantes de Evolución Diferencial en optimización con restricciones," Master's thesis, Laboratorio Nacional de Informática Avanzada., 2001.
- [14] A. Engelbrecht and G. Pampara, "Binary differential evolution strategies," pp. 1942–1947, 2007.
- [15] J. Holland, *Adaptation in Natural and Artificial Systems*. University of Michigan Press, Ann Arbor., 1975.
- [16] C. Houck, J. Joines, and M. Kay, "A Genetic Algorithm for Function Optimization: A Matlab Implementation," *Technical Report NCSU-IE-TR-95-09*, 1995.
- [17] C. Coello Coello, "Introducción a la Computación Evolutiva," *Available online: <http://delta.cs.cinvestav.mx/ccoello/genetic.html>*, 2012.
- [18] J. Koza, "Genetic Programming: On the Programming of Computers by Means of Natural Selection," *MIT Press: Cambridge, MA, USA*, 1992.
- [19] L. A. Romero, V. Zamudio, M. Sotelo, R. Baltazar, and E. Mezura, "A Comparison between Meta-heuristics as Strategies for Minimizing Cyclic Instability in Ambient Intelligence," *Sensors 2012*, 2012.
- [20] F. Wilcoxon, "Individual comparisons by ranking methods," *Biometrics Bulletin*, vol. 1(6) (1945) 80–83.

Biopolis

Vasileios Anagnostopoulos^{a,1}, Emmanuel Sardis^{a,2}, Anastasios Doulamis^{a,3}, and Theodora Varvarigou^{a,4}

^a*Institute of Communication and Computer Systems - ICCS / NTUA
9, Iroon Polytechniou Str., GR-157 73, Zografou, HELLAS*

¹*email: vanag@mail.ntua.gr*

²*email: sardism@mail.ntua.gr*

³*email: adoulam@cs.ntua.gr*

⁴*email: dora@telecom.ntua.gr*

Abstract. The Biopolis takes a radical approach to the long term preservation of digital user content. The system will allow Biopolis enriched User Content to be distributed and redistributed through a set of commercial and non-commercial services (Preservation Services), while ensuring a lasting relationship between the holder and owner of the intellectual content.

Keywords. preservation of digital content; cloud storage; content metadata; multimedia storage;

Introduction

The Biopolis takes a radical approach to the long term preservation [6] of digital user content by using the ideas proposed and detailed in [3]. The goals are similar to [7] but with a very different implementation based on modern achievements in the arena of databases, namely NoSQL [8]. The system will allow Biopolis enriched User Content to be distributed and redistributed through a network of commercial and non-commercial services (Preservation Services), while ensuring a lasting relationship between the holder and owner of the intellectual content. Taking the uploaded digital content from end user which consists of multimedia files like photos and videos referring to city events, places, exhibitions, buildings layouts and interesting archeological sites, the Biopolis will become a time based museum not only for sights of architectural interest suitable for study and e-visiting but also for the municipality cultural events and the faces of the city through time. This innovative idea will provide for the next generations the ability to explore and learn through an electronic time-machine about their city past and current happenings and their neighboring ongoing activities. As a matter of fact the general and originating idea of Biopolis could be extended and applied in a huge number of ‘museum’ based services in electronic

¹ Corresponding Author.

² Corresponding Author.

³ Corresponding Author.

⁴ Corresponding Author.

format through cloud based infrastructures and Internet technologies that make available the search and presentation online through web and mobile devices of this important for the culture and civilization content.

The project aims to explore the possible development of content for safeguarding citizens. Consider the multiple facets. The long-term preservation of the content of the project will be a key research outcome with extensions of industrial interest. Consequently this research will engulf benefits for partners - doing businesses in information technology while integrate and coordinate their research with the aim to enable, applications and services on the Internet for the further development of cultural heritage.

1. BASIC SYSTEM OUTPUTS

The basic outputs from the project are the following:

- *Distributed conservation of content.* The project aims at the endorsement of User Content sharing on a network preservation services operated by different organizations and groups, will ensure that you keep a selection of content
- *Maintaining logical point-and-shoot.* The project investigates direct content acquisition processes by integrating the camera of the mobile device, the semi-automation of the annotation and the submission of content in a transparent manner as, soon as it is created.
- *Automatic content description.* The project supports methods for automatic annotation of content as it is created, using not only the content of the image but also the broader context in which it was created and any copyright restrictions imposed.
- *Selective preservation content.* The project will explore the assessments made by the editors and creators of content, with the goal of rationalization of collections and content maintained meeting several preservation standards, according to the probable long-term cultural value.
- *Reallocation content.* The will support mechanisms for reallocating content preservation to various commercial or non-commercial organizations with the use of the Internet.
- *Preservation metadata.* The project will explore the methods of substitution of user content with content of general interest.
- *Mapping copyright.* The project will ensure that the content is kept manageable, facilitating a lasting, permanent and transportable relationship between content owners and copyright holders.

2. SYSTEM ARCHITECTURE

The main system architecture is presented in “Fig. 1”. Using the Internet technologies the end user can upload digital content (images, video, etc.) through the web-based interface of the Biopolis system. Digital content takes GPS positioning attributes based on user location in the Municipality of Athens and automated preloaded or self and dynamically introduced metadata keywords for content characterization and

categorization [2]. Content contains digital rights from end user in order to be used either for public, or for business cases and corporate purposes.

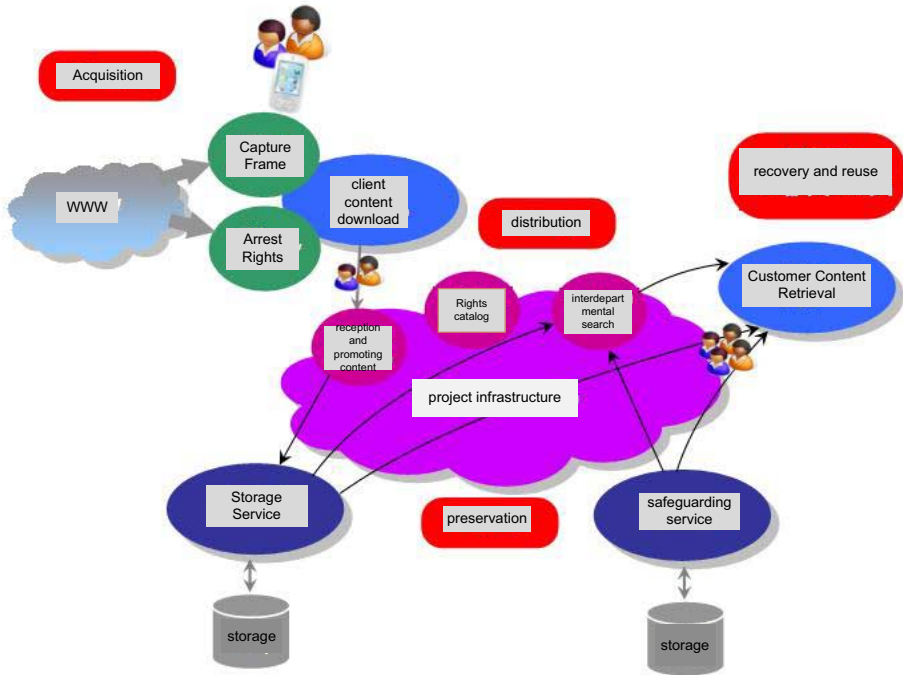

Figure 1. Biopolis Architecture.

The storage of the digital content is stored after passing a filtering mechanism, which main role is to characterize the content for permanent, or not storage. Cloud technologies for storage support the services for ‘storage service’ and ‘safeguarding service’. The services of ‘acquisition’, ‘distribution’, ‘preservation’ and ‘recovery and reuse’ are supporting the Biopolis web and mobile interface in order to be able the users for searching, and be guided for related content, based on their geolocation position, or by searching keywords.

The Biopolis infrastructure is beyond classic storage web sites and services all over the web, that provide digital content through time base and graph-like relational capabilities [4]. Biopolis supports the time attribute on the digital content storage, something that can be used and exploited in many business cases and applications. Moreover provides a satisfactory semantic association of metadata and content through a graph-like organization of uploaded material.

3. TECHNOLOGIES

The involved technologies that Biopolis system will be based for its implementation are the following:

- Storage through cloud computing

- IoS [3] technologies over the web
- Mobile technologies
- Cultural based innovation in digital libraries
- Data management and metadata automation
- Time based storage and search services
- Digital libraries from stored content and administration
- E-government [9] and e-business supported

4. USER INVOLVEMENT IN BIOPOLIS

“Fig. 2” represents the user activities and roles into the Biopolis architecture. The platform for user support and services usage is based on a classic Html5 [10] user interface for the web browsers, and on a mobile developed platform using Android based coding.

System requirements according to the Biopolis usage scenarios and project objectives have been considered to support people with disabilities. The mobile interface is the core platform for everyday usage by the residents of the city and supports directly the geo-information for (x,y) positioning coordinates in the city area. This information is used by Biopolis system in order to collect and manipulate the related tagging and keywords for the media item that will be loaded from a current position in the city area. Also, using Google maps widget’s service, the end user can perform the same functionality from a web browser.

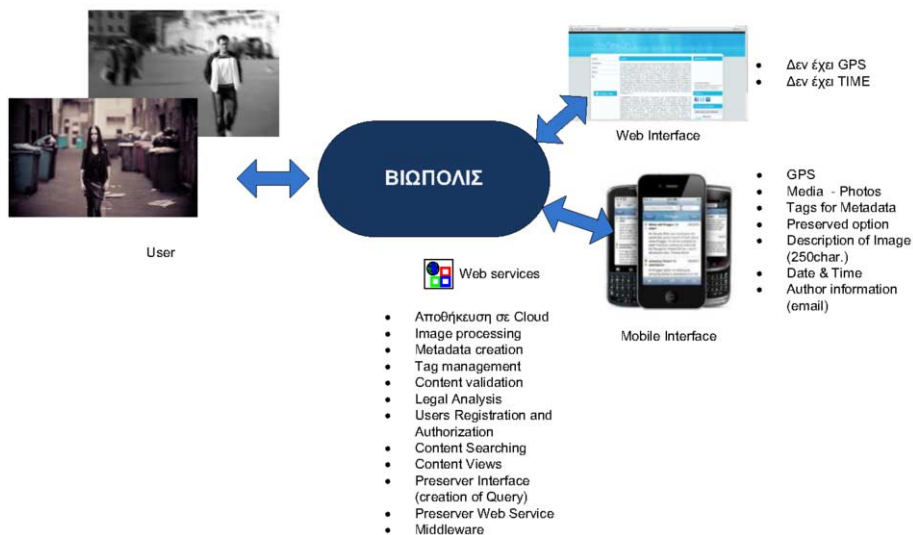

Figure 2. Users in Biopolis infrastructure and their roles.

The user should have the ability to import images while manually determine position and time. The introduction should be done for individual files or group of files, while determining the semantic identifiers (tags). Also, the end user will be able to design high level semantic queries to search for content in online survey contact. End user can construct queries on uploaded content current (volatile storage space) and queries from specific users' media content. It can also query libraries of content (preservation storage space). CRUD (create, read, update and delete) operations are allowed for the end users and librarians.

5. METADATA SERVICES

The module in Biopolis system that manages uploaded media contains metadata (Metadata Management), provides the related services that perform either the automated handling of the metadata per media item or library and the batch process of metadata queries over the already stored media items in Biopolis database.

It should be mentioned that metadata is used during the storage functionality from the end users, in order to classify their media according to the spatiotemporal, characteristics and subject (form a predefined hierarchical dictionary) that the media item contains. Also the Biopolis metadata management module performs automated classification based on image processing algorithms that are running on groups of media data and extracts further info in order to classify, and finally suggest more detailed keywords. These two categories of keywords (predefined and automatic) are presented to the user for final fusion with ideas similar to [11].

6. NEXT STEPS

In Biopolis the first demo is not the end. Moreover new questions and new research areas are spawned during the development of the first demo. One of the future steps is the integration of the Google Goggles [5] service in order to increase the reliability on the suggestion of keywords or the validation of the content. Crowdsourcing could be also used for this purpose. But key to the project is performance. The initial prototype is developed on a platform agnostic generic layer. Afterwards, various combinations of storage layers and business logic inference engines will be used in order to optimize for the best choice. The large amount of off-the-self options makes this task hard because this evaluation must be additionally accomplished on a running system. In this respect care must be taken in order to allow this possibility. Finally a deployment on a cloud-provider will uncover hidden assumptions that should be re-examined in the delivery of the final product

7. Conclusions

This paper presented the main idea and architecture of the project Biopolis. A project related to long term preservation of digital user content. Already, the involved partners have reached the first year of the project duration (3 years total) and according to the user requirements and projects objectives are now facing the implementation of the first

pilot for the mobile and web user. Cloud based architecture for storage and related services have been described in order to provide a whole view for the project benefits.

8. Acknowledgments

The present work was funded by Synergasia 2009 programme (project code: 09SYN-72-954 Biopolis). This programme is cofounded by the European Regional Development Fund and National resources. We would like to acknowledge the partners of Biopolis project, Technical University of Crete Department of Production Engineering and Management, Athens Technology Center (ATC S.A.), and City of Athens IT Company (DAEM SA).

References

- [1] Biopolis official web site, <http://www.viopolis.gr>
- [2] Dietze S., Maynard D., Demidova E., Risse T., Peters W., Doka W., Stavrakas Y., "Entity Extraction and Consolidation for Social Web Content Preservation.", SDA 2012: 18-29
- [3] Cardoso J., Voigt K., Winkler M., "Service Engineering for the Internet of Services ", Enterprise Information Systems, LNBIP, Vol.19, pp. 15–27, ISSN:1865-1348, Springer, 2009
- [4] Rodriguez M.A., "Graph Databases and the Future of Large-Scale Knowledge Management," Invited Lecture for Risk Analysis Symposium, Risk Analysis of Complex Systems for National Security Applications, Decision Applications Division and the Center for Nonlinear Studies, Santa Fe, New Mexico, April 2009.
- [5] Google Goggles, <http://www.google.com/mobile/goggles/#text>
- [6] Burge T., "Content Preservation, " The Philosophical Review, Vol. 102, No. 4, pp. 457–488"
- [7] Jin X., Jiang J., de la Rosa J.L., "PROTAGE: Long-Term Digital Preservation Based on Intelligent Agents and Web Services ", ERCIM News 2010
- [8] Sadalage P., Fowler M., " NoSQL Distilled: A Brief Guide to the Emerging World of Polyglot Persistence", Addison-Wesley, 2012 ISBN 0-321-82662-0.
- [9] Fountain J., "Building the Virtual State: Information Technology and Institutional Change", Washington, D.C., Brookings Institution Press, 2001.
- [10] HTML Working Group, <http://www.w3.org/html/wg/>
- [11] Filippova, K., Hall, K.B., "Improved video categorization from text metadata and user comments.", In Proc. SIGIR (2011) 835-842

iForest: Exploring Crowd-based Intelligence as a Means of Improving the Human-Computer Interface in the Cloud-of-Things

Idham ANANTA^{a,1}, Vic CALLAGHAN^b, Jeannette CHIN^c, Matthew BALL^b, Jazi Eko ISTIYANTO^a, Susi DARYANTI^a and Michael GARDNER^b

^aUniversitas Gadjah Mada

^bUniversity of Essex

^cAnglia Ruskin University

Abstract. The Cloud-of-Things is a holistic vision about the future of pervasive computing which joins together many topics including the Internet-of Things, Intelligent Environments, Cloud Computing, Embedded Computing and People. Clearly such system can lead to very complex arrangements and relationships especially when an attempt is made to scale up existing approaches into large heterogeneous interconnected intelligent environments. This paper highlights the problems and requirements for such a model and proposes an architecture we call iForest that can address these problems based on the use of crowd-based intelligence as a means of supporting users of heterogeneous interconnected devices with in a Cloudof-Things paradigm. In particular we present a computational model, based on graph theory, that we hope is a significant step to these ends. This work is ongoing and we will be reporting on our progress in future workshops and conferences

Keywords. cloud-of-things, internet-of-things, intelligent environments, cloud computing, collective intelligence, crowd intelligence, embedded computing.

Introduction

One of the most popular uses of the Internet is for social activities which are facilitated by tools such as social networking, communications, blogs, product recommenders, and crowd funding. These tools empower people by enabling them to harness the potential of community action. Even since the creation of the web, the social aspect has been one of the most influential factors. Tim Berners-Lee, the inventor of World Wide Web is quoted as saying [1] “*The web is more a social creation than a technical one. I designed it for a social effect to help people work together and not as a technical toy. The ultimate goal of the Web is to support and improve our web-like existence in the world. We clump into families, associations, and companies. We develop trust across the miles and distrust around the corner. What we believe, endorse, agree with,*

¹ idham@ugm.ac.id.

and depend on is representable and, increasingly, represented on the Web. We all have to ensure that the society we build with the Web is of the sort we intend”.

Likewise pervasive computing pioneers, such as Mark Weiser, aspire for technology to support the social nature of people as was well articulated in his vision for the “disappearing computer”, where he said [2]“*By pushing computers into the background, embodied Virtuality will make individuals more aware of the people on the other ends of their computer links. This development carries the potential to reverse the unhealthy centripetal forces that conventional personal computers have introduced into life and the workplace. Even today, people holed up in windowless offices before glowing computer screens may not see their fellows for the better part of each day. And in virtual reality, the outside world and all its inhabitant effectively cease to exist. Ubiquitous computers, in contrast, reside in the human world and pose no barrier to personal interactions. If anything, the transparent connections that they offer between different locations and times may tend to bring communities closer together”*

From these quotations it is clear that both Berners-Lee and Weiser’s vision intended that intelligent environments should support social activities. From a user’s point of view, the main difference between an intelligent environment and a virtual world is that, in a virtual world people need to login to it in order to interact with the system whereas people in an intelligent environment are already an integral part of the system, interacting it physically, without the need to explicitly login. Thus, in an intelligent environment, the system is part of the real world where real people have some private and public spaces. In fact, because intelligent environments are social spaces, interaction between two or more people would seem inevitable.

Managing more than one user and more than one environment, and dealing with its complexity is a ‘hot topic’ in pervasive computing research. This paper will highlight the problem of complexity in the heterogeneous intelligent environments, and propose a novel model, iForest, that harnesses social interaction in the form of collective intelligence as a means to provide a better alternative to conventional AI for putting the ‘intelligence’ into intelligent environments. In support of this we also outline a representation scheme for human and devices relationships in such environments.

1. Related Work

The notion of user-centric ambient intelligence goes beyond simply embedding technology into the society, but also seeks to also reinvent interaction between computing and the user in a new way. Using computers has traditionally demanded a significant amount of a knowledge and learning, whereas ambient intelligence seeks to decrease this cognitive load by providing more user-friendly interaction between users and computers [3].

One, notable example is Task Computing which has proposed a user centric model that utilises a semantic scheme to describe the relationship between users, their role and the task being undertaken, based on a particular context. It was developed with the notion of a SRTM (Semantic-Based Role Task Model) which provided a task computing model that was able offer a particular task to the user based on the particular context. Relationships were described as a map (or graph) interconnecting the user’s role, task and context entities. SRTM describes two kinds of relationship between a task and its subtask; Vertical and Horizontal. An example of a vertical relationship

between tasks and its subtask might be part-of, instance-of, etc. This type of relationship is called ‘functional semantics’. An example of a horizontal relationship between tasks and its subtasks is a sequenced choice. These are expressed in relationships called ‘execution semantics’ [4]. Herranz developed this idea further by proposing rule based systems, generated automatically by sets of intelligent agents which managed coordination between one rule and another either by constructing comprehensive rules, that describe all the people involved, or by providing a multi users’ policy via “*meta-agents*”. The structure of coordination could be regarded as blackboards with graphs created by people, their agents to describe the relationships [5].

From a the wider perspective another project, ATRACO [6], addressed the need for functional, structural and semantic adaptation to maintain a preferred situation in highly dynamic environments. The project proposed the notion of an ‘ambient ecology’ and an ‘activity sphere’ to define a ‘Bubble’ concept, which was a virtual container for people, preferences, and associated devices and services, based on a particular application. The challenge was how to maintain the application sphere when changes took place in the ‘ambient ecology’. Sets of intelligent agents and ontologies were devised to create a framework to support this adaptations.

However, these projects also revealed the shortcoming of current research. For example, complexities arise, when an attempt is made to extend the notion of such user-centric smart environments to a larger scale, involving hundred or thousand devices and services in different configurations with crowds of users conducting their own background activities and based on their own individual preferences. To avoid such complexity earlier studies focus on more isolated approachand, as a consequence, tend to overlook the possibility that complexity might not be all bad, but larger scale might bring some benefits that could actually simplify the implementation, or make it more efficient. In this paper we take this latter view, tand explore the possibility that large scale could offer functional benefits that may improve such systems, in particular the performance of AI components through crowd based techniques..

2. Discovering iForest

In our earlier work we have described the CHAMBER [7] (Crowd-based Heterogeneous Ambient Environment Relationship framework), as a mechanism that can take the advantage of crowd-based knowledge in the intelligent environments; see Figure 1. Our earlier work presented our initial data model as descriptions to represent usable knowledge in the framework. However, in this paper, we challenged the model with following questions:

- How to model global heterogeneous interconnected intelligent environments into measurable, manageable, and widely accessible architecture?
- How to deal with complexity by identifying similarities in massive crowd data (big data)?
- How to model the relationship between people and their environments, ?

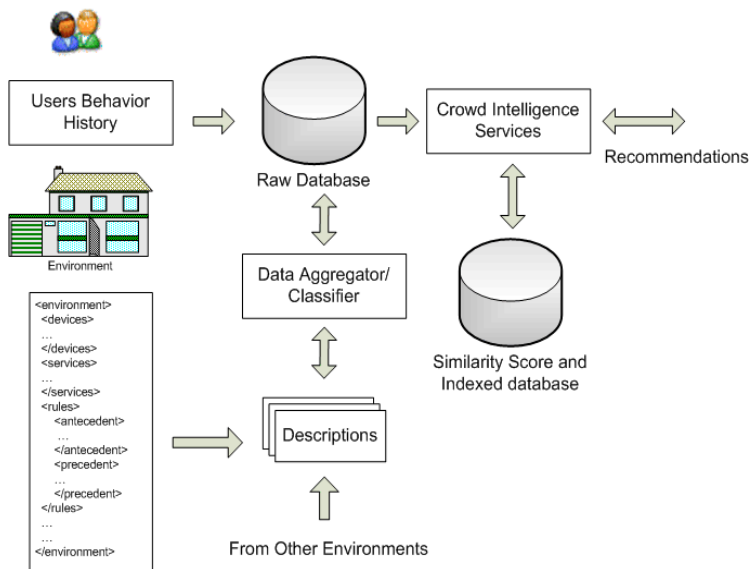

Figure 1. CHAMBER Architecture.

Currently intelligence in pervasive computing is provided in several ways. In small scale systems, software-agents are embedded within the environment (mostly the control devices) to perform simple yet powerful AI operations using techniques such as Fuzzy Logic (these analyze contextual data from networked sensors and user preference to pre-emptively set the environment to meet the user desires). In larger scale systems, researchers frequently use ontology as a knowledge representation, together with a reasoning engine to infer actions.

From a wider perspective, where each local environment constructs its own interpretation about a particular context or preferences, the effort to generate a consolidated intelligence or common sense will be very complicated. Thus, as in our framework, the purpose is to create a global-view model for heterogeneous interconnected intelligent environments. This necessitates the development of a model which can describe all interaction between the user and the intelligent environment based on raw data rather than an aggregation of local interpreted knowledge. This approach is chosen because of following considerations:

- **Similarity discovery** - One of the most important benefits of generating the global view model is to facilitate the exchange of knowledge from one environment to another. However, such knowledge is only useful to others, which have similar/identical contexts and configurations. Thus, finding similarity is very important for this framework. Modeling interaction of users and their smart environments into the raw data model will ease the process to capture their similarities.
- **Effective AI** – AI based predictive systems, such as Microsoft's Intelisense, are notorious for annoying people when their predictions are poor. Thus an important research challenge is how to improve the performance of these systems. Therefore, in our model we are exploring crowd based predictive

mechanisms to provide a more naturalistic reasoning capability that we hope will improve the performance of our predictive recommendation engine.

- **Computational Load** - Shifting the computational load from local site into a centralized, but optimized, service has many advantages such as reducing the processing needs of the local device and enabling the market to offer add-on services such as data mining.
- **Open Systems** - Representing pervasive computing worlds using uniform data structures will offer a simple and open interface that is widely accessible for heterogeneous local environments that will encourage third party development and manufacture.
- **Benchmarking** - By using well-specified data structures and procedures, it becomes easier to create shared benchmarks which can generate standardised data that informs research and leads to better designs.

Based on these principles we have proposed a novel graph based model to represent the complex heterogeneous relationships in interconnected intelligent environments. We argue that, in addition to graphs fulfilling the entire requirements described above, they provide an easy to understand yet visually compelling display. However, the linkage of crowd based AI to pervasive computing creates some unique attributes of this model, that differentiate it from other approaches such as those found in online recommender engines. In our mind this problem space has some superficial similarities to a forest, so we have called this architectural model the iForest.

The iForest model, is presented in figure 2 and consists of a set of vertices and edges. Vertices represent physical entities such as a person or device, together with abstract entities, like context, preferences, etc. Each entity can have its own attributes such as a name, ID, or location. Edges represent relationships between vertices. There are many kinds of relationship possible. For example, entities such as a home, room, light and TV might have structural a relationship that might be written as 'a home has a light', or 'a room has a TV'. The attributes 'person' and 'light' might have functional relationship, such as 'a person switches on the light'. Each relationship might also have attributes. For example, in the 'person changes TV channel' relationship, where attributes such as 'time stamp' and 'particular channel' are attributes. Also there are physical or unique relationship attributes, such as 'energy consumption' or 'location' (some functional relationship include mobility describing movement from one location into another) which might be useful for more advanced intelligent environments development.

There are other reasons to choose graphs. From our perspective, the graph is visually compelling and easier to understand. From a mathematics perspective, there are two mechanisms that could be utilized to represent and operate on "crowd-based intelligence schemes, namely vectors and graph theory. The advantage of vector space representation is the abundance of well defined mathematical operators compared to graphs. However, graph had two advantages, which are its flexibility in term of size or ability to deal with complex topologies, together with their capability to represent binary relationships amongst entities [8] [9] [10]. As the complexity of structure and relationships are two important considerations in our framework, we are exploring the use of graphs.

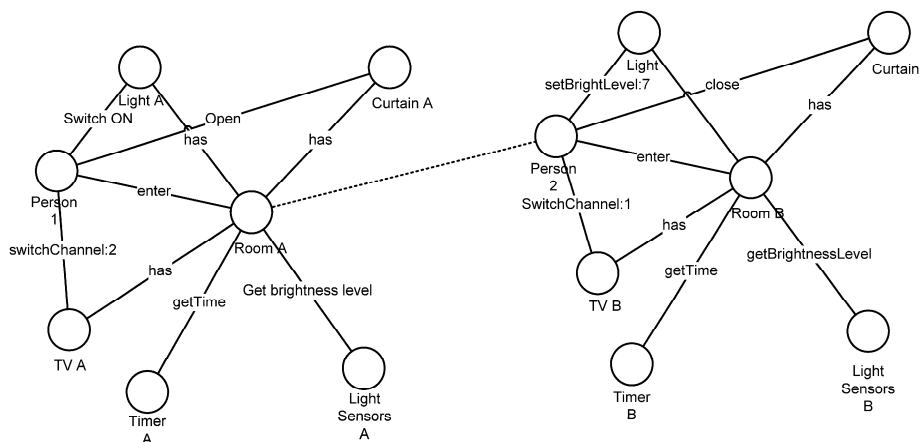

Figure 2. iForest Data Structure.

3. Managing Information of Structure, Behavior and Semantic in iForest

iForest has been designed to contain aggregated information about structure, behavior and semantics. The structure describes a hierarchy between physical devices and their attributes (including name, type, and location) which rarely changes over time. Thus in our model, structured information could be considered as a base layer. Behavior information takes the form of an aggregated record of activities that have occurred in the environment. A simple action like “Kevin switches the light on” can be mapped into two vertices, one is a person named Kevin, and the other is a light with its status attributes (on/off); both are interconnected with a “switch on” action relation, together with their own attributes such as a time-stamp. As behavior changes over time, the behavior graph in iForest could be seen as a dynamic graph, adjusting its relationships in response to ongoing changes. However all behavior information is stored in a persistent database.

In iForest, structural and behavioral information is created automatically in real-time by the local system, and sent to the cloud (with appropriate provisions for privacy). Because the cloud has the potential for significant processing of this data, with the appropriate algorithms, iForest has the potential to augment this sensed data with semantic interpretation based on statistical, structural, or any other pattern recognition on existing graphs. Thus it is possible for iForest to define more abstract entities like context, action, and to suggest rule sets for task composition (eg virtual appliances, meta appliance or applications etc) based on similarity matching across these large graphical data sets. For example, when iForest discovers that most of environments in particular location frequently switch their light on at a particular time, it could offer it as a rule to other environments which have an identical or similar structure/configuration. Likewise, if a physical cluster of environments are using a set of rules (virtual appliance) for say, a security application (maybe the neighborhood has a crime problem) then it might suggest that virtual appliance to neighbours. iForest is a flexible graph based structure and thus can offer an almost endless set of relationships so it could, for example, offer such rule/task with attributes like “most-energy efficient” or “most used” or even “most favoured one” to the user.

4. Implementation

Our broader research objective is to facilitate collaborative work between Universitas Gadjah Mada and University of Essex, as part of a research programme to explore interoperability issues amongst heterogeneous intelligent environments. Towards these ends we have been developing CHAMBER Framework and iForest in the iSpace (see Figure 3) located at University of Essex as our initial test bed.

In this research, an initial data set of user preferences based on particular scenarios was generated from an online survey. It asked students about their behavior in their dormitory (eg study, relaxation, sleep etc). The data aggregated from online survey has been aggregated into the iForest model to support the similarity match algorithm, to supplement the real-time data (as we are unable to get significant numbers of environments, we have to generate the data in this way)..

The iForest then offers recommendations to real iSpace inhabitants, for particular scenario based on an aggregation of real and survey data. By way of an example to illustrate its operation, when the inhabitant going to sleep, it will try to find a best preference match for him/her, using a personalised similarity match. Therefore the iSpace might offer rules to switch the lights off, on, or adjust their brightness level in the dormitory, based on other inhabitants or students similarity level (and preferences).



Figure 3. iForest TestBed

In this way it will also create both social awareness (the inhabitant aware of how many students are studying at the same time, which could motivate him/her to study, for example) and social preferences (when the student wants to watch the TV, he/she could notice the number of the students, who are watching particular TV Show, at the same time).

Thus, both intelligent environment personalisation and social interaction are possible using our CHAMBER framework and iForest model.

5. Conclusion

We have described the need for a data model that can represent the highly complex relationships that exist in heterogeneous interconnected intelligent environments.

Moreover, we have argued that conventional AI is not always the most effective in creating predictive agents for pervasive computing and intelligent environments, as there is a sparsity of sensing, a shortcoming in the types of algorithms that exist and somewhat weighty computational loading; as an alternative we are proposing the idea of utilising crowd based intelligence to create more naturalistic recommendations engines. However, we have pointed out that implementing crowd intelligence intelligent environments is complex, especially in terms of representing relationships, which can be huge (in quantity), diverse (in nature) and highly dynamic (in physical movement and evolving preferences). Also, for this model to function we pointed out it requires hundreds, if not thousands of examples (ie instances of other environments). While these do not exist now, we envisage in the future hundreds, or thousand of physical spaces scattered all over the world (each with tens or hundreds of devices); what we call an interconnected intelligent forest or *iForest*. Such an environment would be occupied by users from various backgrounds, with their own subjective preferences, who actively and continuously interact with intelligent environments around them. At this stage, we have not solved all the problems relating to implementing crowd intelligence in such complex environments, but we have set out the case for exploring this fascinating line of research, together with presenting a computational model, *iForest*, that we believe is a significant step towards these ends. We will, of course, be reporting on our progress in future workshops and conferences.

References

- [1] Berners-Lee, T., *Weaving The Web The Past, Present and Future of the World Wide Web by its Inventor*, Orion Business, 1999.
- [2] Weiser, M. *Computer in the 21st Century*, 1991.
- [3] Hamid Aghajan, Ramon Lopez-Cozar Delgado, and Juan Carlos Augusto, *Human Centric Interface for Ambient Intelligence*. London: Elsevier Inc, 2010.
- [4] Masuoka, R., Parsia, B., & Labrou, Y. Task Computing - the Semantic Web meets Pervasive Computing. *International Semantic Web Conference*, 2003.
- [5] Manuel Garcia-Herranz, Pablo Haya, and Xavier Alaman, "Toward a Ubiquitous End-User Programming System for Smart Spaces," *Journal of Universal Computer Science*, vol. 16, no. 12, pp. 1633-1649, June 2010.
- [6] Christos Goumopoulos and Achilles Kameas, "A Service Oriented Architecture Combining Agents and Ontologies Towards Pervasive Adaptation," in *Intelligent Environment 2009*, Barcelona, 2009, pp. 228-236
- [7] Ananta, I., Callaghan, V., Ball, M., Chin, J., *Crowd-Intelligence in Intelligence Environments: a Journey from Complexity to Collectivity*, to be appeared at The 9th International Conference on Intelligent Environments, Greece, 2013.
- [8] Riesen K., Bunke., Graph Classification and Clustering Based on Vector Space Embedding, World Scientific Publishing, 2010.
- [9] H. Bunke. Structural and Syntactic pattern recognition. In C.H. Chen, Pau L.F., and P.S.P. Wang, editors, *Handbook of Pattern Recognition and Computer Vision*, pages 163–210. World Scientific, 1992.
- [10] D. Conte, P. Foggia, C. Sansone, and M. Vento. Thirty years of graph matching in pattern recognition. *Int. Journal of Pattern Recognition and Artificial Intelligence*, 18(3):265–298, 2004.

A Content-Aware Cloud Platform for Virtual Reality Web Advertising

Markos ZAMPOGLOU ^{a,1}, Athanasios G. MALAMOS ^a, Emmanuel SARDIS ^b,
Anastasios DOULAMIS ^c, Kostas KAPETANAKIS ^a, Konstantinos KONTAKIS ^a,
Vrettos MOULOS ^b, and George VAFIADIS ^b,

^a*Multimedia Content Laboratory, School of Applied Informatics and Multimedia, TEI
of Crete, Heraklion, Greece, www: <http://www.medialab.teicrete.gr>*

^b*Institute of Communication and Computer Systems, ICCS, 9, Iroon Polytechniou Str.
Athens, Greece www: <http://www.iccs.gr/eng/>*

^c*Dept. of Production Engineering and Management, Technical University of Crete,
Chania, Greece*

Abstract. In this paper we present our work towards a remote, cloud-based, large-scale platform aiming at offering Virtual Reality advertisements to end-users on a wide range of terminal devices. While the remote and distributed nature of the platform allows us to display complex content on lightweight devices, the system architecture can also adapt to high-quality content for high-end displays. More importantly, we implement an extended version of the MPEG-7 standard for VR scenes, which allows us to manage the 3D worlds stored in the cloud in a content-aware manner. The system also integrates the dominant standards in the fields of Web 3D and multimedia broadcasting, in order to achieve maximum extensibility and interoperability, towards a platform that will be able to offer lightweight yet immersive VR marketing experiences within Web-based environments.

Keywords. VR advertising, cloud-based 3D repositories, remote rendering, iPromotion, Web 3D

Introduction

While web advertising has been an important commercial activity for more than a decade, it fundamentally still relies predominantly on the traditional mediums of text, image and sound data -however, during the same time period, VR technologies have shown impressive progress. While the potential of VR marketing has been evaluated in the past, with research demonstrating its potential benefits in terms of informativeness and user enjoyment [1,2], the concept has so far remained theoretical. We have undertaken the effort of building a platform, which we have named iPromotion, over which VR advertisements will be distributed to users over the web, allowing them to interact with virtual representations of the advertised goods, thus giving them a fuller, more informative and more pleasurable experience.

¹Corresponding Author: mzampog@epp.teicrete.gr

1. Project aims and description

As a goal, the project has set two distinct usage scenarios for our platform: the first, which we call the "Web & Mobile - Based Scenario" allows a user to retrieve and interact with a complex 3D scene using a mobile phone, while the second, called "Large-Scale Demo," concerns the remote reproduction of a high-quality 3D scene on a touch table or wall projector. The fact that these two tasks appear on the surface to have radically different specifications is misleading: an integrated framework can implement both, by adapting the volume of data sent and the computational load assigned to the client on each occasion. We are in the process of building this framework, and have it comply with the dominant standards in the industry, to increase extensibility and interoperability.

Currently, there is a growing trend of integrating 3D graphics in web pages, under the HTML5 standard. The graphics are taken up and rendered by the browser and the device's graphics card. However, local processing of the 3D data is problematic in a range of scenarios, where bandwidth and computational resources are limited. This can be the case, for example, in our "Web & Mobile - Based Scenario".

To tackle this, we have taken a remote and distributed approach: a cloud storage repository, a remote rendering grid which provides the end devices with only the renderer output, and a number of subsystems for organizing and coordinating the flow of information, to achieve the desired adaptability. Furthermore, the platform is supplemented by a 3D scene authoring tool and an application for automatically extracting MPEG-7 descriptions from 3D scenes, to allow for intelligent content-based search over the 3D scene repository. Finally, the rights of authors over the scenes they have created are maintained and propagated through the entire life cycle of a scene, using the MPEG-21 framework.

The rest of the paper is organized as follows: Section 2 presents the platform architecture. Section 3 presents the more innovative aspects of the platform in greater detail, and finally Section 4 deals with our further steps for the completion of the platform.

2. System architecture

The system (Figure 1) is a service-oriented platform integrating multiple subunits. The sub-units include, besides the core cloud-based STaaS (STorage as a Service) repositories and the grid rendering servers, an authoring tool and a subunit for the automatic extraction of MPEG-7 descriptors and MPEG-21 encapsulation, plus the subunits that manage the content adaptation to accommodate the entire range of possible scenarios.

The STaaS Model Repositories hold all available 3D models and scenes, stored in X3D format, as well as any meta-information available on them, plus any supplementary texture files for the 3D scenes. X3D is an open, XML-based language for 3D graphics, specifically designed for display over the web. We consider X3D to be a good option for its syntactic simplicity and openness, combined with the fact that it's based on XML and is thus easier to integrate with the MPEG-7/21 standards.

The meta-information kept in the cloud repository is not limited to text describing the scene in high-level terms, but also includes low-level content descriptors and semantic metadata, and is stored in MPEG-7 format. Furthermore, the X3D files and their corresponding MPEG-7 descriptors are integrated within the MPEG-21 framework, which also allows the integration of digital authorship and usage rights for each scene. The use

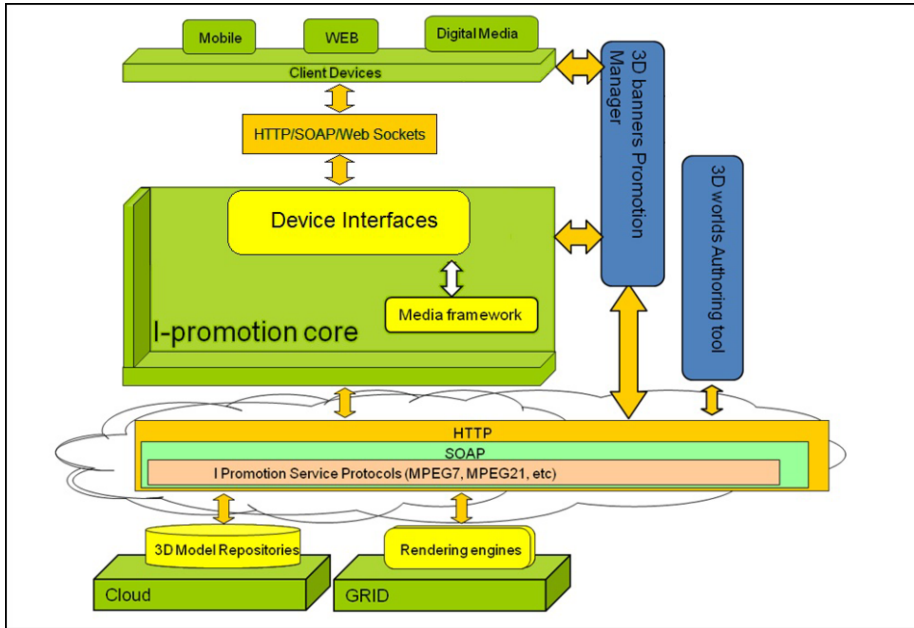

Figure 1. The iPromotion platform architecture

of content description allows for advanced search capabilities, both from visitors, who can chose -or be assigned- a 3D world according to high-level search criteria, and authors using the 3D Worlds Authoring Tool. The latter option is provided so as to encourage content sharing and re-use on the part of the authors -provided the digital rights status of the content allows it.

When a user requests a scene with particular high-level characteristics, the repository is traversed and a search is performed on the MPEG-7 descriptors of the various scenes stored therein. The relevant scenes are selected, and the corresponding MPEG-21 files are read. The corresponding X3D files are then extracted from the repository, along with their supplementary files (e.g. texture images), and forwarded to the Grid Rendering Engine, which renders the 3D model and outputs a sequence of images. Before forwarding the image stream to the end user, the system needs to identify the current user specifications and adapt the output parameters (such as format, resolution and frame rate) to the capabilities of the end device and the connection. The Device Interfaces subunit uses the MPEG-21 Multimedia Adaptation framework for this and then gives the relevant instructions to the Media Framework subsystem, which takes care of any necessary conversions. The User Interface for all use cases always takes the form of an HTML5 web page.

Two separate tools we have developed are the 3D Worlds Authoring Tool and the X3D to MPEG-7 Tool. The former aims at introducing new 3D scenes into the repository, by allowing authors to edit and combine already existing scenes. The Tool is a standalone application, which connects with the repository and offers semantic search capabilities based on MPEG-7 descriptions. When a user locates the models they are interested in, they can import them to the Tool, perform minor modifications (such as altering their

spatial or parameters animation parameters) and store them back into the repository cloud as a new 3D scene. Furthermore, the Tool allows authors to add textual meta-tags to a scene which are consecutively incorporated into its MPEG-7 description. The X3D to MPEG-7 Tool draws from our previous work on MPEG-7 extensions for the description of X3D scenes [3], which we have further streamlined by developing an XSLT-based service for the automatic extraction of descriptors from the files placed in the cloud repository [4]. Further details are offered in subsection 3.3.

3. Novel contributions

3.1. Remote rendering

To achieve independence from the computational limitations of the various end devices, we use a grid rendering system located in our remote servers. Deferring a portion of the computational cost of 3D rendering to a remote server is a well-studied practice [5,6]. For our needs, we have modified the open Xj3D Browser [7] by converting it into an Axis2 Java Web service running over a server and communicating via SOAP messages. When the system wants to provide a user with a scene, the client page sends a message that initiates a session. The renderer loads the scene from the cloud, and begins transmitting (through the appropriate subsystems) the rendered output images. The available options that the User Interface provides include, besides scene load/unload commands, navigation and interactions within the scene: as the user interacts with the client-side HTML interface, appropriate SOAP messages are sent to the platform, and instruct the renderer to adjust the scene accordingly.

3.2. Cloud Storage

One of the main objectives of the proposed cloud storage system is to be able to handle any kind of multimedia files or metadata services that could be sent from the multimedia provider. With this in mind, our data model schema is not strictly structured as a standard RDBMs schema, but can instead include any data/metadata that are required for the application functionality. The file structure hierarchy is described as a JSON file that includes all the necessary files into field brackets, where common fields in a collection documents may hold different types of data.

The objective of this architecture is twofold: (a) define and enable an interface of several heterogeneous information and service entities, (b) create an active pool of technologies, Operating Systems, devices and policies where the cloud storage system could work. To fulfill the requirements, an interoperable structure framework was created, inspired by the NoSQL notion and the data-intensive constrains. The storage system is based on HDFS (The blue box that can be seen in Figure 2) and uses the OPTIMIS data management service [8] to achieve better federation results. A final modification we have performed on the Hadoop framework is the installation of Corona [9], an alternative job-scheduling system that is more efficient for small tasks, but also tasks that are not Map-reduce at all.

The next two layers are responsible for the interoperability, simplicity and compatibility of the framework with a plethora of document multimedia types and applications.

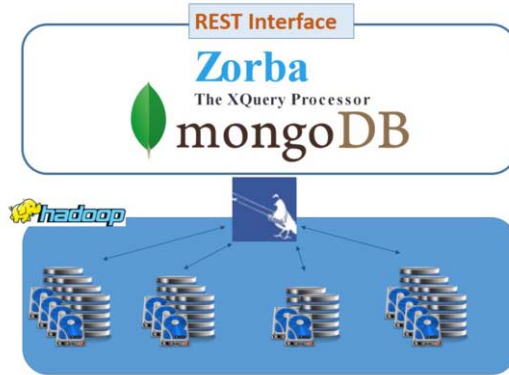

Figure 2. The file storage architecture

The white box in Figure 2 presents the technologies that are used in order to overcome these issues. MongoDB was the best candidate for the data storage as it gives us the flexibility to store data without worrying about following the exact schema. The JSON file is saved as it is in the database and is treated as object. Over that layer we use the Zorba framework [10] as most of the multimedia applications communicating with the database are based on xquery. Zorba undertakes that transformation and provides a unified layer for the framework. Finally the interconnection with the applications and the iPromotion service protocol is provided by a REST service (using the HTTP protocol).

3.3. MPEG-7 extension for 3D scene annotation

For our system, we needed to offer efficient, intelligent and content-aware search capabilities for the 3D scenes located in the cloud repository. In the current state-of-the-art (a survey can be found in [3]), the absence of a unified framework that can describe all important aspects of a 3D scene is striking. To cover our needs, we extended the MPEG-7 standard with a number of novel descriptors for the geometry, lighting, animation, structure, viewpoints and potential interactivity of an entire 3D scene, while also modifying and adapting the original MPEG-7 color, texture and motion descriptors. A full list of the descriptors, their format, and their scope is presented in [3].

However, for a large scale system to work, it is necessary that the descriptors are automatically extracted from the scenes. One of the reasons we have chosen X3D for our scenes is that, as both X3D and MPEG-7 are XML-based standards, we can automatically extract MPEG-7 descriptions from X3D files, using eXtensible Stylesheet Language Transformations (XSLT) between the two XML schemas. While normally an XSL Transformation aims at replacing a source XML tree with the XSLT output tree, what we need to do instead is form a secondary, MPEG-7 XML file to accompany the XML file that contains the original X3D scene. We have thus developed an X3D to MPEG-7 Tool that, given an X3D file, outputs the corresponding MPEG-7 description, validates it (according to our extended standard) and places it in the Repositories alongside the original X3D file [4].

4. Conclusions and future work

We have presented our work towards a large-scale, cloud-based VR advertising platform over the Web. The system is still under development, and, while many aspects (such as the remote rendering, mobile client, cloud repository and X3D to MPEG-7 tool are already functional, we are still progressing towards the final system integration. While certain aspects we have described (such as MPEG-21 compliance or the authoring tool) remain to be completed, the core of the system as presented here offers a powerful market tool for remote, distributed and flexible advertising, while offering a technology with vastly broader implications, in remote VR experiences.

Acknowledgements

The research of this paper is granted by the European Union and the Hellenic General Secretary of Research and Technology under the "COOPERATION 2009 / 09SYN-72-956" Framework.

References

- [1] D. Mazursky and G. Vinitzky, "Modifying consumer search processes in enhanced on-line interfaces," *Journal of Business Research*, vol. 58, no. 10, pp. 1299 – 1309, 2005.
- [2] K.-S. Suh and Y. E. Lee, "The effects of virtual reality on consumer learning: an empirical investigation," *MIS Quarterly*, vol. 29, no. 4, pp. 673–697, 2005.
- [3] P. Spala, A. G. Malamos, A. D. Doulamis, and G. Mamakis, "Extending MPEG-7 for efficient annotation of complex web 3D scenes," *Multimedia Tools Appl*, vol. 59, no. 2, pp. 463–504, 2012.
- [4] M. Zampoglou, P. Spala, K. Kontakis, A. G. Malamos, and J. A. Ware, "Direct mapping of x3d scenes to mpeg-7 descriptions," in *Proceeding of the 18th International Conference on 3D Web Technology June 20-22, 2013 San Sebastian, Spain*, accepted for publication.
- [5] F. Lamberti and A. Sanna, "A streaming-based solution for remote visualization of 3D graphics on mobile devices," *IEEE Transactions on Visualization and Computer Graphics*, vol. 13, no. 2, pp. 247–260, 2007.
- [6] T. K. Çapın, K. Pulli, and T. Akenine-Möller, "The state of the art in mobile graphics research," *IEEE Computer Graphics and Applications*, vol. 28, no. 4, pp. 74–84, 2008.
- [7] The Xj3D Project website, "<http://www.xj3d.org/>," last accessed 23/2/2013.
- [8] G. Kousiouris, G. Vafiadis, and T. A. Varvarigou, "A front-end, hadoop-based data management service for efficient federated clouds," in *Cloud Computing Technology and Science (CloudCom), 2011 IEEE Third International Conference on*, pp. 511–516, 2011.
- [9] The Corona Project website, "<https://github.com/facebook/hadoop-20/tree/master/src/contrib/corona>," last accessed 28/2/2013.
- [10] The Zorba Project website, "<http://www.zorba-xquery.com/>," last accessed 28/2/2013.

ViewPoint: An Augmented Reality Tool For Viewing and Understanding Deep Technology

Malek ALRASHIDI^{a,1}, vic CALLGHAN^a, Micheal GARDNER^a, and Jennifer B.
ELLIOTT^b

^a *University Of Essex, UK*

^b *University of Cincinnati, USA*

Abstract. This paper will explore the use of augmented reality, and its ability to reveal deep technologies (hidden technologies)¹, as a means to create more effective tools for developers or students studying embedded computing, which are typified by topics such as the *internet of things, pervasive computing and robotics*. This approach aims to enrich the experience for developers and learners by constructing a meaningful view of the invisible things around us. Thus, we will propose and explain a general model, called ViewPoint, which consists of several components such as learning design specification, collaborative environments, augmented reality, physical objects and centralised data. Furthermore, to support the proposed model, we present a 4-dimensional learning activity task (4DLAT) framework which has helped us to structure our research into several phases where we can scale up from single-learner-discrete-task to group-learner sequenced-task, based on the proposed scenario. As a first step towards these lofty ambitions, this study will focus on developing Internet-of-Things systems based on a small self-contained eco-system of networked embedded computers known as Buzz-Boards.

Keywords. Mixed Reality, Augmented Reality, Internet-of-Things, Cloud-of-Things, Learning Activity, Mobile Augmented Reality, Buzz-Boards.

Introduction

Since the beginning of creation, learning has been one of the most natural things in human life. People like to be involved in a process whereby they can gain knowledge and skills and improve themselves. Furthermore, with the advancement of technologies and the development of techniques, the possibility of using these technologies in the field of education has increased and they are considered an important means to improve and develop the learning of students. Pena-Rios [1] describes some of the technologies used in the education sector, such as mixed reality, augmented reality and virtual environment, which have transformed learning and teaching from traditional methods to new high-tech methods. In addition, collaboration and interaction in these technologies can be exploited in educational practices. Also, the exercises in

¹ Corresponding Author: Malek Alrashidi, School of Computer Science & Electronic Engineering, The University of Essex, 5B.525, Wivenhoe Park, Colchester, CO4 3SQ, UK, E-mail: mqaalr@essex.ac.uk

collaborative learning have advantages in terms of enabling learners to clarify their ideas and develop better concepts through the discussion process[2].

Linking real and virtual worlds allows augmented reality to create a reality that is both enhanced and augmented[3]. Augmented reality provides new possibilities for learning and teaching, which have been recognized by educational researchers[4]. Learners can benefit from the coexistence of virtual objects and real environment in several aspects. First, it allows learners to visualise complex spatial relationships and abstract concepts[5]. Second, learners can interact with 2D and 3D synthetic objects in the Mixed-Reality (MR)[6]. Third, it allows phenomena that are not existent or impossible in the real environment to be experienced by the learners. Finally, it allows learners to develop important practices that cannot be developed in other learning technology environments[7]. These advantages have made augmented reality one of the key emerging technologies for learning and teaching over the next five years[8]. In addition, connecting various innovative technologies such as mobile devices, wearable computers and immersive gadgets, could create augmented reality[4]. However, the educational benefits of augmented reality not only concern the use of the technologies but also how augmented reality is designed, implemented and integrated into learning settings, both formal and informal[4]. AR might be based on technology, but it should be conceptualized beyond technology [4].

To this end, the aim of this work-in progress is to explore how augmented reality could be used to make the invisible things visible in order to construct a meaningful view for developers and learners to understand better the abstract concepts of the internet-of-things surrounding us. As a first step towards these lofty ambitions, we have proposed an AR model we call ViewPoint which we propose to apply to the development of an Internet-Of-Things based desktop robot that is constructed from a small self-contained eco-system of networked embedded system known as BuzzBoards [30].

1. Related Work/Literature Review

1.1. Mobile Augmented Reality

Augmented Reality (AR) is an approach centered on the overlay of virtual objects in a real-world context, and has the ability to induce in users feelings of sub-immersion through facilitated interactions between virtual and actual world[9]. Augmented Reality (AR) integrates or mixes generated virtual objects in real world images. From the user's perspective, the objects rendered complement reality and coincide in the same environment [10]. Accordingly, there is the need for alignment between the virtual world and the real one; this will facilitate the creation of such an illusion. A number of theoretical AR applications have been examined, including entertainment, maintenance and repair, manufacturing, medical visualisation, and robot environment planning[11]. AR necessitates accurate scene registration, which subsequently causes the issue of camera pose prediction in the context of the 3D environment [12].

Mobile AR is recognised as being an organic platform geared towards various 'killer apps', as they are named. It has been highlighted by Wagner et-al[13] for instance, that an interactive AR museum can be described as "a virtual media that annotates and complements real-world exhibits". In this same vein, a training application is introduced by[14]which enables the staff of oil refineries to observe

instructional diagrams positioned on top of the tools being utilised and learned. A number of other applications are known, such as [15], equipment maintenance [16], and document annotation [17], amongst others. Regardless of the application, however, there are a number of characteristics in common. For example, all of these applications depend on there being vast distributed and dynamic data, and there is a need for all links between relevant data and recognisable visual targets to be maintained. Such links will ultimately alter through application development or with the growth of the underlying data. Essentially, there is the need for the presence of a presentation layer, which describes how data can be rendered as virtual media. In some instances, although this rests on the data's nature, it may be sensible to render various mixes of icons, images, texts or 3D objects. The exact conversion from information to virtual content ultimately rests on the type of application. Various users adopting different mobile devices could be able to collaborate and share data. This therefore suggests the requirement of a central data store with the ability to monitor the actions of users, as well as the system state overall[18]. In addition, collaboration in augmented reality can be more valuable, especially when multiple users discuss, state their viewpoints and interact with 3D models at simultaneously[19]. However, for educational purposes, much research has already been done in the area of collaborative AR which used 3D objects [20,21,22], for example: the struct3D, tool which was used to teach mathematics and geometry[23] ; Web3D, which was used to help engineering students[24] ; and magicbook, which were used for multi-scale collaboration. Most of these applications are based on screen-based AR, using see-through displays, and see-through head-worn displays. Moreover, augmented reality has the potential to provide multiple points of view of the same object, which can aid learners to go further than the information available to them[25].

1.2. Internet-Of-Things

It was stated by Ferscha et-al [26] “smart things are commonly understood as wireless ad-hoc networks, mobile, autonomous and special purpose computing appliances, usually interacting with their environment implicitly via a variety of sensors on the input side and actuators on the output side”. In addition, the hidden functionalities of any system that humans cannot see are considered deep technologies. These hidden technologies are embedded in the environment and are invisible to human sight, although they are still there. They can increase users' perception of the environment surrounding them, if presented to them in a natural way. Thus, linking the physical world with the virtual one is an important aspect, and this can be achieved by using means such as mixed reality or augmented reality. For example, Ferscha et-al [26] developed a 6DOF DigiScope, a visual see-through tablet that supports “invisible world” inspection. Another example is the University of Essex's iClassroom, which includes projectors, whiteboards, wall-mounted touch-screen, and handheld devices which are all networked together in order to aid learning and teaching [1].

1.3. Learning Activities and Pedagogical Approach

The IMS (Instructional Management System) produced by the Global Learning Consortium has defined specifications that can be used to create, plan and share a collection of learning activities that students can achieve during an online session [1,31] (Figure 1). Units of Learning (UoL) is the structured sequenced of activities; this

can be led by zero or more conditions before completing or starting the tasks; the teacher, on the other hand, creates the UoL by using the services in the environments. The goal of this structure is to allow students/learners to achieve the learning goal. These specifications have several benefits, such as completeness, personalisation, formalisation, compatibility and reusability.

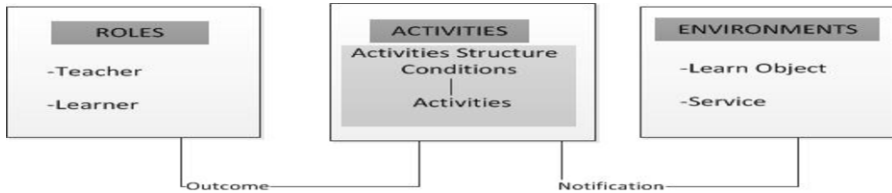

Figure 1 IMS Learning Design Specification (adapted from [1])

A good description of a learning theory is an effort directed towards explaining the way in which people learn, thus facilitating understanding of and insight into the intrinsically complicated learning process. Human learning is undoubtedly complicated, and a number of different scholars have suggested various theories on the different types of learning[27]. The basic learning theories centred on people can be broken down into three many categories, namely behaviourism, cognitivism, and constructivism [28]. The objective of this paper is to utilise the constructivism theory in order to devise augmented reality learning using smartphones/tablets. Importantly, it is held by constructivists that learning is an on-going and continuous process, where learners are seen to create their own knowledge in line with individual preferences according to their experiences within a matrix; this is commonly established by the instructor or otherwise as a result of a search carried out by the learner[29]. In addition, knowledge may also be garnered through the sharing of viewpoints [28].

2. System Model

A high-level view of the proposed model, ViewPoint, is shown in Figure 2. This is based on several aspects that integrated together such as the learning design specification (Figure 1), the collaborative environment, the augmented reality characteristics, the physical objects and the central data that manage the whole system.

Theses aspects can be further described as follow in more details:

- a) *LD Specification*: the teacher creates the unit of learning, the learning objective, the expected learning outcomes and specifies the task that should be completed by the students. Furthermore, the students perform a sequence of actions to achieve the goal of the activities that set by the teacher. In addition, they would be able to see their performance and score for the task which would be retrieved from their personal content profile and could also can be seen by the teacher.
- b) *Collaborative Environment*: This is where multiple users with separate smartphone/tablets can communicate, collaborate and share data during the learning activities. Furthermore, the environment can notify other users for the updating data/information.

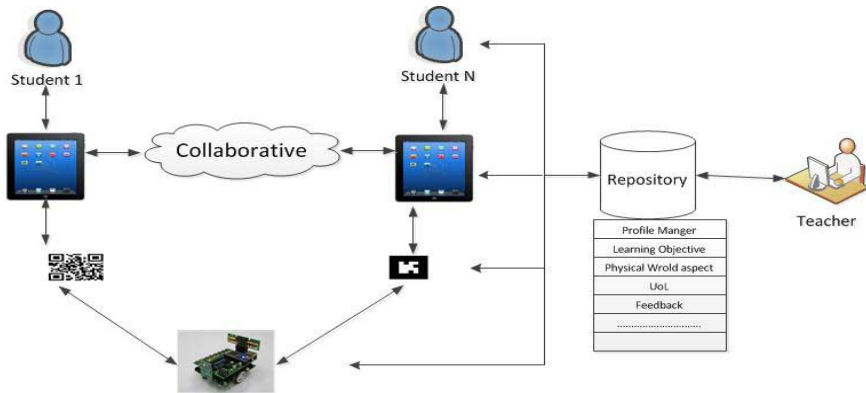

Figure 2 High-Level View of the ViewPoint Model

c) *AR Characteristic:*

- *AR Display:* Is the user interface/ the client application/ the output device where users can see things on top of devices' camera, and these things/artefacts can be rendering, recognized and tracked in order to overlay virtual content in the user display such as text annotation, icons , video, image and 3D model.
- *Visual Targets:* Is the techniques/targets to be used in order to access and interact between the real objects and the virtual objects. The interaction could be undertaken by diverse technologies such as Quick Response code (QR), Bar Code, Near Field Communication (NFC), Video Markers, Computer Vision (object recognition), Global Position System (GPS), interactive sensor/effector systems and computer networks (e.g. micro sub-nets).

d) *Physical Objects:* Is the object which the users want to track, visualize and manipulate. The physical objects could range from the things that we use in our daily life such as cars, washing machine, TV, aeroplane, robotics, Buzz Board (Figure 3) to the mobile technologies.

e) *Central Data:* Is the repository where the whole system managed. This contains all the Units of learning, assessments, Role for users (teachers and students), the share data, the virtual content, and the physical objects functions/representation.



Figure 3 Some BuzzBoard Internet-of-Things Components (an Internet Radio)

2.1. *Augmented Reality Scenario*

John is a smart teacher who always makes great ideas/tasks for his students, which motivate and engage them in the activities. John teaches embedded system at The

University of Essex, which maintains the state-of-the-art embedded system laboratories, and which comprises all the facilities needed for learners, from hardware through to complete software, such as Robotics. Many computer science and engineering students find the embedded system abstract subject difficult to learn and understand. For this reason, John devised an idea that uses advanced technology, such as Augmented Reality, which may reveal the hidden aspects/functionalities/process in the embedded system, thus facilitating students' understanding in a better manner.

John created a maze escape for robots as a test bed (Figure 4), and assigned a task for students to write software to build a desktop robot that can escape in the maze (based on BuzzBoard technology [30]). The assignment is structured in such a way that each student assumes responsibility for building one function of the robot control system (e.g. obstacle avoidance, Path follow, turning left/right, reading signpost). When combined into the final robot solution, none of these internal functions are visible. In order to test and debug their robot, the students use standard debugging tools, although this can commonly result in a disconnection between the problem abstraction and the behaviours, as exhibited by the real robot. In this scenario, the students each use an iPad/tablet to point at the robot and to determine the invisible aspects of the robots from various perspectives while discussing the problem. They can then combine as a team to develop the robot together as well as seeing how the robots functions in the real practice.

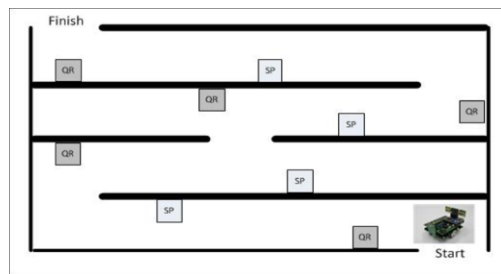

Figure 4 Maze Escape Scenario

In order to make the maze-escape more fun, John distributed several cards/visual targets for the students, such as QR code, NFC, Barcode, etc., which the students could place in the maze-escape in order to reach the final target faster. These cards are represented as signposts for the robot, which tell the robot which direction should be followed, or which may otherwise simply tell the robot for more information, such as location and clues, etc. The student can track the robot and see how it interacts with these cards by using their iPad/tablet. Figure 5 shows the modularised robot which is assembled by students who plug together various hardware and software modules (there is also potential for students to create their own software and hardware).

2.2. Implementation Approach

The proposed scenario can be broken into sub-tasks; this is scale from single-user discrete-task to multi-user sequenced-task (easy to difficult). These tasks are represented in a learning activity framework (Figure 6), as this work-in progress, our aim is to go through all the tasks based on the scenario.

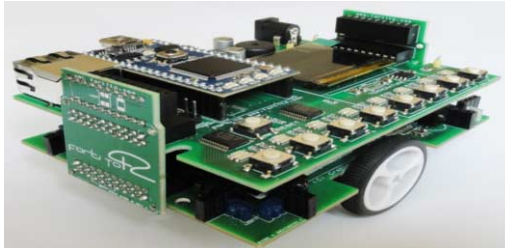

Figure 5 The BuzzBot (a modularised educational robot)

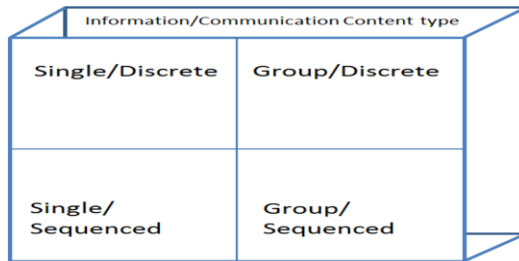

Figure 6 4-Dimensional Learning Activity Framework

The learning activities tasks utilise a Fortito’s Buzz Boards which is an educational technology toolkit that contains several software and hardware modules [30]. It is used to produce students’ assignments and projects, both interesting and simple such as mobile robots, mp3 players, heart monitors etc. Buzz-boards can be assembled using various methods. A variety of hardware applications can be made that then allow students to program in order to gain skills and motivations. Moreover, the functionality and physical form of buzz-boards are determined by the concept of pluggable modules. Buzzboards provide a lot of information that is useful to the AR system via the network. Examples include providing ID when they join the micro-net ,or sending out events when modules are plugged together, or when actions occur (user or device), all of which can be integrated with other sources such as cameras [30].

The focus of this paper is to describe the left side of the framework both single learner discrete and single learner sequenced task. Both tasks are based on a UoL schema so as to achieve the learning objective of each task. The single-learner discrete-task gives the learners the basic knowledge for constructing a Buzz-Board module. The task works by allowing students to work individually in order to identify the different pluggable modules of the buzz boards by pointing their tablets/smartphones over visual targets that represent each module. This will overlay virtual information about each module such as text annotation, image or 3D module that gives additional information for the students such as its use, function and process. It might also pictorially show software or communication process, plus sensory fields, which are normally invisible to the student.

In the second dimension, single-user sequenced-task, the learning objective is to allow the learner to construct the whole buzz board modules together. The users/learners can follow step by step instruction which guide them to build the final modularized modules using their tablets. However, in case of plugging the buzz board

wrongly, the augmented reality should inform the learners about it and give a suggestion for example; go back to the previous steps. In addition, the learners can view different layer of information representation, this will allow the learners to view the whole components of the buzz board module, or focusing on one component of the module.

Finally, the following stage of the implementation consists of the construction of the right side of the framework where both group-learners discrete and group-learners sequenced tasks are undertaken. The aim in the right side is take the research into more complex situation where a variety of collaborative tasks are carried out simultaneously by several users.

3. Conclusion and Future Work

In this paper we have explored the use of augmented reality, and its ability to reveal deep technology (hidden technologies), as a means to create more effective learning tools for students studying courses in embedded computing, which is typified by topics such as the *internet of things, pervasive computing and robotics*. This approach aims to enrich the learning experience for learners by constructing a meaningful view of the invisible things around us. Thus, we proposed and explained a general model, ViewPoint, which consists of several components such as learning design specification, collaborative environments, augmented reality, physical object and centralised data. Furthermore, to support the proposed model, we produced a 4-dimensional learning activity task (4DLAT) framework. This helped us to structure our research into several phases where we can scale up from single-learner-discrete task to group-learner sequenced-task, based on the proposed scenario. The paper explained the implementation of left side of the 4DLAT framework, whereas the right side will be one of our aims for future works for this research.

In our future plan, we aim to continue implementing the left side of the research, and using the buzz board system as a physical object and pedagogical test bed for our experiment work. In addition, there is still much research to be done, this relates to how to create effective learning design activity using augmented reality as well as the interaction procedure with the invisible technology. In addition, finding the appropriate techniques for visualizing embedded technology requires further investigation. Furthermore, the evaluation of our work is a crucial factor which we will take it into consideration on our future progress. Finally, we look forward to presenting more on this work-in progress at future conferences.

References

- [1] A. Pena-Rios, V. Callaghan, M. Gardner, and M. J. Alhaddad, "Towards the Next Generation of Learning Environments: An InterReality Learning Portal and Model," in *2012 8th International Conference on Intelligent Environments (IE)*, 2012, pp. 267–274.
- [2] C. Steeples and T. Mayes, "A Special Section on Computer-Supported Collaborative Learning," *Computers & Education*, vol. 30, no. 3, pp. 219–21, 1998.
- [3] S. C. Bronack, "The Role of Immersive Media in Online Education," *Journal of Continuing Higher Education*, vol. 59, no. 2, pp. 113–117, 2011.

- [4] H.-K. Wu, S. W.-Y. Lee, H.-Y. Chang, and J.-C. Liang, "Current status, opportunities and challenges of augmented reality in education," *Computers & Education*, vol. 62, pp. 41–49, Mar. 2013.
- [5] T. N. Arvanitis, A. Petrou, J. F. Knight, S. Savas, S. Sotiriou, M. Gargalakos, and E. Gialouri, "Human factors and qualitative pedagogical evaluation of a mobile augmented reality system for science education used by learners with physical disabilities," *Personal Ubiquitous Comput.*, vol. 13, no. 3, pp. 243–250, Mar. 2009.
- [6] L. Kerawalla, R. Luckin, S. Seljeflot, and A. Woolard, "Making it real": exploring the potential of augmented reality for teaching primary school science," *Virtual Real.*, vol. 10, no. 3, pp. 163–174, Nov. 2006.
- [7] K. Squire and E. Klopfer, "Augmented Reality Simulations on Handheld Computers," *Journal of the Learning Sciences*, vol. 16, no. 3, pp. 371–413, 2007.
- [8] L. F. Johnson, A. Levine, R. S. Smith, and K. Haywood, "Key Emerging Technologies for Elementary and Secondary Education," *Tech Directions*, vol. 70, no. 3, pp. 33–34, Oct. 2010.
- [9] Y. Uematsu and H. Saito, "Vision-based Augmented Reality Applications," in *Computer Vision*, X. Zhihui, Ed. InTech, 2008.
- [10] O. Y and T. H, *Mixed Reality, Merging Real and Virtual Worlds*. 333 Meadowlands Parkway, Secaucus, USA: Springer-Verlag New York Inc, 1999.
- [11] D. Schmalstieg and D. Wagner, "Experiences with Handheld Augmented Reality," in *6th IEEE and ACM International Symposium on Mixed and Augmented Reality, 2007. ISMAR 2007*, 2007, pp. 3–18.
- [12] R. Azuma, Y. Baillo, R. Behringer, S. Feiner, S. Julier, and B. MacIntyre, "Recent advances in augmented reality," *IEEE Computer Graphics and Applications*, vol. 21, no. 6, pp. 34–47, 2001.
- [13] D. Wagner and D. Schmalstieg, "Handheld Augmented Reality Displays," in *Virtual Reality Conference, 2006*, 2006, pp. 321–321.
- [14] M. Träskbäck and M. Haller, "Mixed reality training application for an oil refinery: user requirements," in *Proceedings of the 2004 ACM SIGGRAPH international conference on Virtual Reality continuum and its applications in industry*, New York, NY, USA, 2004, pp. 324–327.
- [15] D. Wagner, T. Pintaric, F. Ledermann, and D. Schmalstieg, "Towards Massively Multi-user Augmented Reality on Handheld Devices." In *Proceedings of the Third international conference on Pervasive Computing (PERVASIVE'05)*, Hans-W. Gellersen, Roy Want, and Albrecht Schmidt (Eds.). Springer-Verlag, Berlin, Heidelberg, 208-219.2005
- [16] S. Feiner, B. Macintyre, and D. Seligmann, "Knowledge-based augmented reality," *Commun. ACM*, vol. 36, no. 7, pp. 53–62, Jul. 1993.
- [17] J. Rekimoto and Y. Ayatsuka, "CyberCode: designing augmented reality environments with visual tags," in *Proceedings of DARE 2000 on Designing augmented reality environments*, New York, NY, USA, 2000, pp. 1–10.
- [18] J. Mooser, L. Wang, S. You, and U. Neumann, "An Augmented Reality Interface for Mobile Information Retrieval," in *2007 IEEE International Conference on Multimedia and Expo*, 2007, pp. 2226–2229.
- [19] D. van Krevelen and R. Poelman, "A Survey of Augmented Reality Technologies, Applications and Limitations," *The International Journal of Virtual Reality*, vol. 9, no. 2, pp. 1–20, Jun. 2010.
- [20] A. Henrysson, M. Billinghurst, and M. Ollila, "Face to face collaborative AR on mobile phones," in *Mixed and Augmented Reality, 2005. Proceedings. Fourth IEEE and ACM International Symposium on*, 2005, pp. 80 – 89.
- [21] J. Caarls, P. Jonker, Y. Kolstee, J. Rotteveel, and W. van Eck, "Augmented reality for art, design and cultural heritage: system design and evaluation," *J. Image Video Process.*, vol. 2009, pp. 5:2–5:2, Feb. 2009.
- [22] M. Billinghurst, H. Kato, and I. Poupyrev, "The MagicBook: Moving Seamlessly between Reality and Virtuality," *IEEE Comput. Graph. Appl.*, vol. 21, no. 3, pp. 6–8, May 2001.
- [23] H. Kaufmann, D. Schmalstieg, and M. Wagner, "Construct3D: A Virtual Reality Application for Mathematics and Geometry Education," *Education and Information Technologies*, vol. 5, no. 4, pp. 263–276, Dec. 2000.
- [24] F. Liarokapis, N. Mourkoussis, J. Darcy, M. Sifniotis, A. Basu, P. Petridis, and P. F. Lister, "Web3D and Augmented Reality to support Engineering Education," *World transactions on Engineering and Technology Education*, vol. 3, no. 1, pp. 11–14, 2004.
- [25] P. Milgram and F. Kishino, "A Taxonomy of Mixed Reality Visual Displays," *IEICE Transactions on Information Systems*, vol. E77-D, no. 12, Dec. 1994.
- [26] A. Ferscha and M. Keller, "Real Time Inspection of Hidden Worlds," in *Proceedings of the Seventh IEEE International Symposium on Distributed Simulation and Real-Time Applications*, Washington, DC, USA, 2003.

- [27] J. Bransford, R. Stevens, D. Schwartz, A. Meltzoff, R. Pea, J. Roschelle, N. Vye, P. Kuhl, P. Bell, B. Reeves, and N. Sabelli, "Learning theories and education: Toward a decade of synergy," in in *Handbook of educational psychology*, P. Alexander and P. Winne, Eds. Erlbaum, 2006, pp. 209–244.
- [28] R. Saengsook, "Learning Theories and eLearning," in *Third International Conference*, Bangkok, Thailand, 2006.
- [29] B. Parhizkar, Z. M. Gebriil, W. K. Obeidy, M. N. A. Ngan, S. A. Chowdhury, and A. H. Lashkari, "Android mobile augmented reality application based on different learning theories for primary school children," in *2012 International Conference on Multimedia Computing and Systems (ICMCS)*, 2012, pp. 404–408.
- [30] V. Callaghan, "Buzz-Boarding ; practical support for teaching computing based on the internet-of things," on *The Higher Education Academy - STEM*, London, 2012.
- [31] IMS Global Learning Consortium, "Learning Design Specification," IMS Global Learning Consortium, 2003. [Online]. Available: <http://www.imsglobal.org/learningdesign/>. [Accessed 08 2012].

IF Alice Arrives, THEN Wonderhome Incites

Tiina KYMÄLÄINEN^{a,1}

^a*Aalto University, School of Art and Design, Department of Design*

P. O. Box 31000, FI-00076 Aalto, Finland

E-mail: tiina.kymalainen@aalto.fi

Abstract. The science fiction prototype ‘Alice’s incitements in Wonderhome’ introduces an intelligent home for the aged that provide motivational and personalized activities, assistance, and memory support. The prototype is based on two intelligent environment research studies: 1) a study that constructed a do-it-yourself creation and configuring tool into a nursing home environment, and 2) a study that aimed at finding means for seniors to compose their memoirs. The science-fiction prototype highlights important results of both studies by emphasising the motivational aspects of configuring the environment. It further describes new interaction mechanisms afforded by future technologies and novel research opportunities for the cloud of things.

Keywords. Intelligent environment (IE), science fiction prototype (SFP), human-computer interaction (HCI), home for the aged, do-it-yourself (DIY) approach, cloud of things (COT)



Figure 1. Hologram forest – the Cloud of Thoughts.

¹ Corresponding Author: Tiina Kymäläinen, Permanent address: VTT Technical Research Centre of Finland, P.O. Box 1300, Finland, Email: tiina.kymalainen@vtt.fi

Background and Settings

The objective of a science fiction prototype (SFP) in intelligent environment (IE) research context is to illustrate long-term solutions for the technology, and introduce new opportunities and designs applicable in near or distant future. The SFP of this article, 'Alice's incitements in Wonderhome', is based on two inspirational IE research studies. These studies were carried out in the EU-funded DIYSE-program, Do-It-Yourself Smart Experiences (<http://dyse.org/>), which aimed at enabling ordinary people to easily create, setup and control applications in their smart living environments as well as in public environments. In Do-It-Yourself (DIY) IE the hypothesis is that the smart environments are constructed piecemeal with easily available, controllable and configurable components. Users are expected to be initiative and active constructors of their living environments, who share the responsibility of constructing, configuring and maintaining the technology. The first inspirational study developed a proof-of-concept home control system and a creation and configuring tool to an intelligent nursing ecosystem for elderly [1]. The second study constructed a service for writing, publishing and sharing personal recollections – life stories – for senior citizens [2]. Both studies examined profoundly the user expectations, embedded values and usability issues in relation to the chosen technologies.

The title of this paper introduces a simple rule: IF Alice arrives THEN Wonderhome incites. The title holds privileged humour for all struggling with the philosophical underpinnings of IE research – the “unbearable lightness” of the endless possibilities to encode the ubiquitous and adaptable technology, in contrast to the “heaviness” of the real-world unpredictable and value-saturated decryption and use. The study for developing the configuration system begun by creating scenarios, short stories, to illustrate the opportunities and usage situations of a hypothetical patient of a nursing home, a persona called Alice. The very first rule that was created (relating to the Bluetooth-lock control) begun by “If Alice arrives...” Henceforth, the research group ended up creating large number of potential rules to the system that were evaluated further with users. It was soon remarked, however, that the utmost importance was to find most evocative use cases and stories that illustrated the incitements and motivations to use the systems. Yet, logically, the greatest amount of construction material was gained at the end of the project – and, by the account, the motivation for writing this science fiction prototype becomes obvious.

The SFP is constructed around most important themes of the inspirational research studies. The first study provides substance about the motivations of people configuring, customising and personifying their environments in a do-it-yourself fashion, the inspiring and supporting role of the system, the self-actualizing part of the construction process and the preference to multimodal systems, haptic interfaces and spoken language dialogue interaction. The second study provides inspiration for the configuring activity – the creation and sharing of private memories. The SFP elaborates the findings of the original studies, places them into a concrete environment, and proceeds with what was not accomplished in the projects.

Essentially, the SFP illustrates the social connection between an elder parent and an adult child facing the challenges when moving in to a nursing home. The key philosophy in the construction objective relates to Yi-Fu Tuan's concept of “topophilia”, which can be defined broadly “to include all of the human being's affective ties with the material environment” [3]. Transferring Alice's experience of home to the nursing home offers an intriguing opportunity to explore the concept.

Tuan's study of environmental perceptions, attitudes, and values elucidate that topophilia towards a place that is the locus of memories, i.e. home, is more permanent and less easy to express than any other perception. Furthermore, the 70's environment for the SFP has been adapted from Ellen Langer's "counterclockwise" study, in which elderly men lived for a week as though it was 1959, took more control over their lives and seemed to grow younger [4]. Evidently, an intelligent, configurable environment has manifold and specified means for the objective. The side characters' diagnoses are roughly adapted from Oliver Sacks novel "The man who mistook his wife for a hat, and other clinical tales" [5]. The purpose is to exemplify motivations for personifying the environment and define the needs for exclusive interfaces and smart products. Acknowledged by Johnson's concept of SFP [6] the novel technologies – in this case, the use for the cloud of things, advanced interaction mechanisms and new data visualisation techniques – aim to redefine what can be done and how can be interacted in future intelligent environments.

1. Alice's incitements in Wonderhome

1.1. *She's Leaving Home*

During the entire trip to the home for the aged Alice was silent. Kay, her daughter, overtook that to be the final way for her mother to show discontent. But Kay was afraid after Alice had had a stroke and two serious falls with fatal consequences. Alice was afraid, too. Her condition was not getting better: she had astrocytoma, a brain cancer in the star-shaped brain cells, which could not be removed. Now that Frank, Alice's husband, had unexpectedly passed away, Kay was the only one looking after her. And Kay could not be there for Alice all the time. She had two children, husband Sam, her work in the city and a newly renovated house.

When Alice and Kay had visited Wonderhome, a compassionate nurse had introduced the settings. The apartments were furnished with most exclusive technology for monitoring inhabitants, as well as providing assistance, activities and entertainment. One important purpose of the technology, as the nurse had explained, was to encourage inhabitants to take control over their lives and perform simple but vital tasks by themselves – such as taking medicine, preparing tea and meals and dressing up – to the extent that was humanely possible due to distinct physical disorders. Alice didn't like the idea. She had a nurse visiting twice a day, and the arrangement had worked extremely well. Top off the nurse's introduction had been, when she had stressed that the wonder of the Wonderhome was not the fancy technology, but the Wonderfamily that Alice was soon going to be part. Alice didn't appreciate the idea of having housemates either. She was used living by herself – and she loved it. Besides, she had important things to do – important, *private* things – relating to something her husband has said as his last words.

1.2. *Wonderhouse, Dull house and Dollhouse*

Once Alice had walked into her south-wing apartment, she felt suddenly something she didn't expect. While entering in, she felt vaguely as if coming home. She anticipated that the sensation was the cause of many things: the room was furnished, as expected, with her dearest belongings, photographs and portraits – and even with the custom-

made wallpapers she had at home. But also more profound elements were in their familiar places: sockets, door handles, lamps and light-switches. They even worked as accustomed. Kay saw Alice's well-hidden astonishment when she proudly presented all the configurations she had made for the apartment. She said,

'The idea is that everything in here is as close to the conditions at home, mom.'

'They don't fool me. This not my home,' Alice replied resentfully.

'I know. But there are also so many improvements compared to home,'

Kay went on, not minding about Alice's remark,

'For example, if you don't want to get up in the morning, you can just call out all things of the apartment, and they do the morning tasks for you.'

Kay said things like "turn on the TV", "turn on the lights in the living room" and "fill the bathtub", by causing each thing to react. Alice tried to look unimpressed, although it was getting more and more difficult. She also understood that Kay had gone through considerable efforts when making the adjustments to the apartment.

'You may call out the things of the house wherever you are. You can ask, for example, the teakettle to be turned on in the shared kitchen.' Kay elaborated,

'But the most important thing is that the house is observing you, all the time. No harm will pass its surveillance. And it does things for you. The lights will softly turn on in the morning, when its time to get up. And if you wake up at night, the night-lights will turn on, so that you may find your way to the bathroom.'

Kay led Alice to the bedroom. Just when Alice thought that there were no more surprises left, she recognized a familiar dollhouse next to her bed (see Figure 2). Frank had originally made the miniature copy of Alice's house to Kay.

'Do you remember when I moved from home to study? Frank packed the thing with me, once he had made some configurations to it.'

'I remember,' Alice said quietly as she recalled the situation,

'He connected the lights of our home to match the little lamps of the dollhouse. Whenever we turned on a lamp, the matching lamp turned on in the dollhouse. They were supposed to signal you if we were at home, if we were asleep or awake.'

'The lights were a clever way of implying if you were available for a conversation,' Kay said and continued,

'I thought that you might appreciate the dollhouse in turn, Mom. I have adjusted the lamps to match our house in turn. You can see when we are at home and when I have gone to bed. It could be a way of saying "good night".'

Then Kay pointed towards a night lamp next to Alice's bed, and explained that it had been adjusted to Kay's home lamp in her upstairs corridor. When Alice would turn it off, it would signify when Alice had gone to bed.

Alice watched as Kay did some final fine-tuning to the dollhouse, and thought that Kay was truly her father's girl, all the way down the line. But Alice was careful not to show her appreciation.

Eventually, Kay left. She had said that during the first days, the apartment would learn Alice's preferences and tune the rooms accordingly. But Alice had no preferences! She resentfully practiced with the lights of the apartment by calling each of them in turn. It was strange, but at least she felt she had some control of her environment.

As the day turned into a night, Alice watched how the little lights of the dollhouse begun to turn off. When the last light faded, Alice thought bitterly how her daughter was probably sleeping more peacefully than ever, knowing that Alice was under

constant surveillance and observation. And that was exactly why Alice couldn't sleep. She felt that by moving into the nursing home, nonetheless how wonderful, she had lost her integrity. Alice rebelliously left on the night lamp. She recalled that Kay could see the related corridor lamp from her bed.

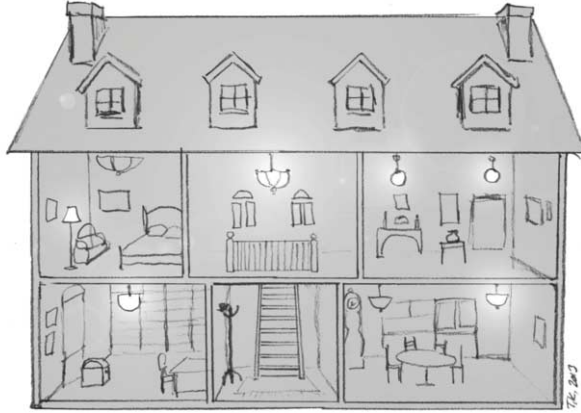

Figure 2. The Dollhouse for subtle communication.

Then Alice glanced at Frank's portrait in the bedroom wall. She instinctively tried to rub her wedding ring, which she had lost in the removal. She had been too ashamed to tell Kay about it, but now the situation made her feel twice as frustrated. Oh, how she missed Frank, their home and the life she had been forced to leave behind. But then she remembered Frank's harassing words, his bothering secret, which gave her another reason to stay awake. His exact last words had been,

'Do I still have time? There is the last confession I want to share with you Alice.'

Then, just before he had died, his voice had turned into mumbling,

'The key is... key is, Elise.'

All Alice could think, ever since, was: "Who the heck is Elise?"

1.3. *Wicked Witch of the West*

The next morning Alice was supposed to be acquainted with the other residents of the floor, but because of her poor night's sleep the circumstances were not most constructive. Still, Alice had to go to the kitchen if she wanted to have breakfast.

Alice met first Tom, the east-wing resident, who was an absentminded man in his eighties. He seemed to look somewhere above Alice while introducing himself and a weird music surrounded him once he focused on his breakfast again. Alfred, the north-wing resident, seemed to be more level headed: he had intelligent eyes, but a coarse, workman's handshake.

Fran, the west-wing resident, entered the kitchen theatrically and didn't introduce herself at all. She grasped idle looking Alice under her wing and forced her to the kitchen corner. The pompous lady pointed a statement in a smart-memo-board and harassed how important it was to encourage inhabitants to make things by themselves. The way Fran presented the goods and the kitchenware, Alice thought that she acted as if she was a nurse. Fran went on with her chattering and warned that Alice shouldn't

think that because there were two men in the room, women should do all the work. Fran, herself, was doing that, but after all, she was hosting the place and, clearly, much younger than Alice. Before Alice could retort, Fran dragged her to the rest of the shared rooms and praised their modernism. The rooms were decorated in 70's style.

Fran disappeared to the hallway, as quickly as she had come, and Alice went back to the unfamiliar kitchen. Bravely she managed to make a decent breakfast for herself, with the help of her assisting avatar that appeared to the smart-memo-board. Alice had chosen the character long time ago to help in real- and virtual world situations such as this – when she did not know the way. Her avatar was a butler-rabbit.

‘Such a clever avatar!’ Alfred commented and went on,

‘Mine resembles of my dog. Oh, how I miss the real thing! It brought such joy to my life: the way it looked at me and the way it appreciated simple things.’

Tom didn't seem to notice Alice's avatar. He replied to Alfred's statement,

‘I miss my orchestra. Nothing can fulfil the experience of playing in a concert.’

Suddenly, Fran was back to the kitchen. She joined in:

‘And I miss work! Not this trivial labour that I am doing here, for the time being, but my true call as an actress!’ She added theatrically,

‘I am waiting and waiting, but the phone never rings!’

Alfred furrowed, looked Fran and said,

‘Fran, you are disturbingly starting to sound like the characters in Beckett's play “Waiting for Godot”.’ Then he chanced his voice and imitated,

‘You divert yourself while waiting for something imaginary to happen “*if not in the evening but surely tomorrow*”.’

Alice looked Alfred curiously. Clearly she had made a misjudgement regarding him, and his workman manners. Fran looked Alfred anxiously, but seemed to miss his point. Her voice turned suddenly chilly as she declared,

‘Yet at this moment, in this instant, I miss most my shiny, silvery shoes. And when *the call* comes, I will *need* them.’

After a dramatic pause she turned her gaze towards Alice and continued,

‘Shoes do not walk by themselves, which means that someone has taken them. Men hardly have use for ladies' shoes; and thereby the only suspect is *her!*’

Fran was pointing at Alice and accused stealing her shoes the very first time they met! Alice was appalled. She didn't know how to respond to such impulsiveness, such arrogance. And she thought she was too old for the compulsory games of defining the pecking order of a new company. She looked first at Tom, who didn't seem to realise what was going on, and then Alfred, who winked his eye to Alice. He turned to Fran and retorted, as dramatically as Fran,

‘You wicked witch of the west! Why don't you use the smart-memo-board to find the lost things and stop harassing our newcomer!’

Then he was more smoothing,

‘I will help you with your shoes, but before we do that, Fran dear, you might as well tell something about yourself to our Dorothy here. For example, how old are you?’

Alice's assessment of Fran's age was a bit over eighty.

‘Why, you should know better than that, not to ask the age of a lady! But I might as well tell you – if you promise you don't tell my agent. I am thirty-nine.’

Alfred gave an evocative glance to Alice and continued,

‘Well, for such a young person, you probably don't have any trouble in remembering what year it is?’

Fran looked baffled for a moment. Then she smiled,

‘Poor old thing, you must be getting quite senile. The year is, of course, 1976!’

Alice glanced her pocket-watch-display just to make sure. In the display the butler-rabbit was proactively presenting needed information: the year was 2018. Alfred was not a bit discomfited about Fran’s retort, but went on by taking a magazine from the kitchen table. He presented Fran an article of a famous actress, Meryl Streep, and asked,

‘Fran, you are an actress. Can you tell me who the person in the picture is?’

‘Never seen in my life! Must be some shooting star, they come and they go. Oh, she looks so skinny. A bit like Audrey, but not as sophisticated, you know what I mean.’

Then Fran stood up, collected empty cups and plates, and went by the kitchen sink. Alfred noticed Alice’s confused expression. He lowered his voice and explained,

‘Fran really was an actress. She has an unusual version of Korsakov syndrome, and it causes her to think that time has frozen into 1976. That is why all the rooms are decorated in 70’s style, although there is more to it. It is for all our well-being; to make us feel younger. You probably noticed all the trouble that they had seen to make you feel at home, as well? But you should see Fran’s apartment! Her room is an exact copy of her apartment – in 1976. There are extreme details there in place: stains in the carpet, thresholds measured of exact height, force feedback in the doors and a broken thermostat that works improperly but which has obvious logic to Fran.’

‘Why?’ Asked puzzled Alice.

‘To make her feel comfortable. Not to confuse her. There is no time capsule to retrieve her back from the 70’s, Alfred said and continued,

‘But there is one thing missing from her apartment, though.’

‘What is that?’

‘A mirror. If she saw her reflection, that would break the illusion. She resembles Dorian Gray in that part.’ Alfred quoted the play melodramatically,

‘If it were I who was to be always young, and the picture that was to grow old! For that-for that-I would give everything!’ Then he whispered quietly,

‘So Alice, don’t ever show her a mirror, unless you truly want to upset her.’

Alice saw no reason to do that. Alfred concluded by saying:

‘Fran thinks that she is looking after us, but in fact, it is the other way around. The truth is Alice; that we are here looking after each other.’

After saying that Alfred went to help Fran. His assisting avatar dog led them to the lost shoes by barking louder when discovered.

1.4. *BeQuest Drawer-Chest*

Alice withdrew to her south-wing apartment, whilst she thought she had enough social life for a day. Alice had an important mission – a mission that required her undivided attention. Alice sat beside a huge, solid oak cabinet, which Frank had called the BeQuest drawer-chest (see Figure 3). Alice was hoping that the chest, with its forty-eight drawers, could help to reveal Frank’s mysterious secret.

Frank, her philosophical handyman, had spent most of his spare time devoted in renovating Alice’s house, but this new project had been his latest, his last, passion. Frank had been extremely proud of the cabinet and called it “the foundation of the human mind”. According to him, it had space to hold an entire well-classified world of a person, and once one had put something in it, it could never be lost. Frank had begun the project soon after Alice’s tumour had been discovered, and after, according to Frank’s judgment, Alice started to forget things. Frank had said that Alice needed more memory-exercises and the drawer-chest provided plenty of those.

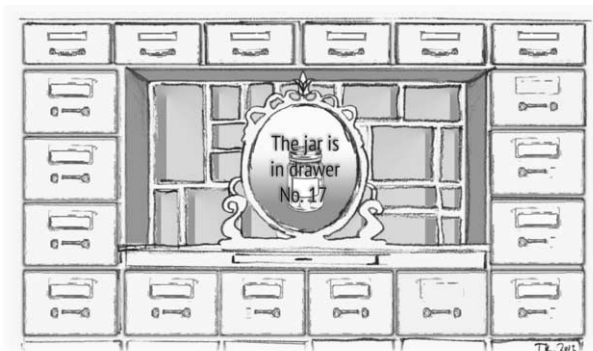

Figure 3. BeQuest drawer-chest.

The significance of the drawer had become clear after an incident. Alice was a keen conserver, and she was in trouble each autumn when it was time to store the pickles. Alice noticed some large, empty drawers in Frank’s cabinet, which she wouldn’t ever have dreamed of using, if it hadn’t been an emergency. Alice had put the pickle jars in the drawers, and thought nothing of them, until Frank had found her cache. He had been shocked and accused her of “abusing the foundation of the human mind” and “turning his reasoning cabinet into a larder”.

After calming down, he had used a pickle jar as an example how the cabinet worked. He enclosed a label into the jar, put it in front of a looking-glass display and asked Alice to explain the content. Confused Alice had done as asked, and Frank put the jar to one of the drawers. Then Frank smiled to her and requested for the jar. Alice witnessed how the looking glass required more specific details and Frank replied with roughly something that Alice told about the content. The looking glass revealed the number of the requested drawer. Frank put the container in front of the looking-glass reader and there was Alice’s voice explaining the content with a supplementary pickle recipe drawn from the cloud.

Then Frank opened up another drawer, took his father’s medal of honour and to Alice’s surprise, exposed detailed wartime stories from many sources relating to the medal. From that time on, Frank stored all their most important things into the cabinet, and asked Alice to help him to save their shared recollections. Later, Frank had told that the drawer did not open up to just anyone. There were secret compartments that opened only to him, Alice and Kay – and they requested secret, articulated passwords.

Alice was convinced now that Frank’s gloomy secret was encapsulated in the drawer. She said aloud “Elise”, but the looking-glass display didn’t react. Then Alice tried the backdoor that Frank had created in case of problems. She asked,

‘Magic mirror in the chest, I request: who is Elise?’

The looking glass remained silent.

1.5. Hologram Forest

The day after, Alice decided to take another approach for finding out the secret. With a word ‘forest’ she asked for a hologram woods to ignite itself into her living room (see Figure 1). The hologram forest was a place for all the digital traces of Alice’s life: all the things she had done, all the places she’d been, and all the communication she had

ever had. In other words: the hologram forest was the outsourcing of Alice's memory. The forest emerged as a garden of diverse trees, with various shapes, colours and sizes. The trees held branches, which held leaves, which held memories and reminiscences. The information had been implanted into the forest according to Alice's preferences; a tree was bigger if it held a significant amount of memories; it was taller if it was older and a tree had a specific gloom if it had been browsed recently. Regularly, Alice mostly browsed the maples, because they held all her dearest photographs. She practically never browsed the willows that held her regularly updating medical information or sprouts of junipers that was the new sensor data of the Wonderhome.

In addition with her own part of the forest, Alice had partial access to other people's grounds. Now that Frank was dead, with his authorisation, she had inherited his entire forest. Up until this moment Alice hadn't had time to visit there.

Now Alice crossed over the border, and visited the parts she had been able to visit before. Then she came to an unfamiliar meadow. Alice had a feeling that this could be the place to start her search. She inhaled and called out "Elise". The word echoed back. At first nothing seemed to happen, but then she heard how the branches rustled, and a tiny, familiar face peeked out from the shrubbery. It was the butler-rabbit again, who gave her a rude glance, turned around, and headed deeper into Frank's forest. Alice followed him, as usual.

The rabbit led her to a tense willow growth that seemed to contain Frank's old lecturing files. It shook a tree, and dropped a leaf to Alice's hands. It was an essay from a girl named Therese, apparently tagged with label of her nickname Elise. Alice browsed the content by moving her eyes. As she was not satisfied, the rabbit led her to a non-glooming large oak and dropped some leaves that contained photographs of an old family friend, Elisabeth. Alice knew she wasn't the one she was looking for either. Then the rabbit shook his head and bounced over to Kay's forest, but Alice felt weary and did not follow. She thought she was now totally, utterly lost with the secret.

1.6. Come Together

The homecoming party for Alice was in the following evening. Alice had invited all her new roommates to see her apartment. Alfred sat next to Alice in the sofa, looked at her warmly and said:

'I am glad you moved to live with us, Alice. It is so pleasant to have someone with some sense and sensibility.'

'I admit I had some prejudice towards Wonderhome's endless observing, self-help demands and especially, the housemates. But I have swallowed my pride and know now that this was the best thing that could've had happened to me.'

Alfred was looking at Fran and Tom, who were browsing the BeQuest drawer-chest. Alice had adjusted the looking glass *not* to show the camera reflection, and there were only few drawers open to satisfy the curiosity of the occasional browsers. Accordingly, there was only the exhibit garden accessible in Alice's forest. Alfred sighed,

'Those two don't have much use for the hologram forest.'

'How come? I couldn't live without it.'

'Fran has not any digitalized recollections before 1976, and as her memory endures only about fifteen minutes, she quickly loses interest to browsing.'

'What about Tom, then?'

‘He is another story. Tom has no visual memory or imagination. The world presents itself quite absurd to him. He cannot understand the hologram forest at all. In fact, he doesn’t comprehend any faces, images or objects around him.’

‘But he recognized me this morning, called me by the name!’

‘He has a device that he carries with him for the purpose. In the device his Dormouse avatar acts as a prompter and whispers the names. It recognises people’s faces, voices and walking-styles. And the labelled objects around Wonderhome obviously know Tom.’

‘And is there some reason why he is surrounded by music all the time?’

‘Indeed! Tom used to be a distinguished musician. Now that he does not understand things around him and what they are for, the world has been constructed according to something he understand very well – music. He has identifiable songs for every act and procedure. He has songs for dining, dressing up, even for taking a bath.’

As they were speaking, Tom came to sit next to Alice. He appraised,

‘Your cabinet seems extremely interesting, Alice. But what do you do with the hologram thing, the forest? The Dormouse told me that it is for tracing back memories, but I don’t understand. What kind of memories?’

Alice sighed. She was feeling too comfortable to conceive a lie to her new friends.

‘I might as well tell you, since I have come to a dead-end with my investigations. For the last few days, I have been trying to solve my late husband’s secret. Something he said to me in his deathbed.’

Both men leaned attentively closer to Alice. They said in unison:

‘What did he say?’

‘He said: “I have a last confession. And: the key is Elise.” Alice said and sighed,

‘I am convinced that the secret is hidden in the drawer-chest.’

To Alice’s great surprise Tom chuckled and said,

‘That is a catching tune! I have used it myself for remembering how to prepare tea and madeleine cookies.’

‘I beg your pardon?’ astounded Alice sighed.

‘I mean the most famous Elise of all: “Für Elise” by Beethoven. Now that I think of it, of course the notes could be used as a secret key. The letters that spell Elise can be decoded as the first three notes of the piece. Because an E \flat is called an Es in German and is pronounced as “S”, that makes E–(L)–(I)–S–E: E–(L)–(I)–E \flat –E...’

Alice wasn’t listening anymore. Intuitively she understood that Tom had solved the mystery. She asked gingerly:

‘Could you please play it for me, with my old piano in the corner?’

Tom graciously did as asked. All listened to the scenic music that Tom played effortlessly without any hesitation or absent-mindedness. Alice sat by the drawer-chest and observed the lockers. Then the music stopped, but nothing happened.

1.7. Last Note

After a good night’s sleep, the answer came to Alice. It came to her in a flashback memory. She had heard Frank’s last words as a mumbling: “The key is... key is, Elise”, but, in fact, she understood now, he had said: “The key is Kay’s Elise”.

When Kay had practiced the tune, as a child, she had persistently always misplayed the third note. Alice called Kay; who came and played the piece. As she hit the magical note, she simultaneously looked at her mother in a way that made Alice

understand that she had plotted this whole thing with Frank. A locker opened up – not in the drawer-chest, but in the dollhouse. It notified about the event by continuing to play “Für Elise” and guiding the source of the sound to the tiny living room. Alice picked her missing wedding ring from a small chest. Intuitively, she took the ring next to the looking-glass reader of the drawer-chest. The mirror informed that the ring contained Frank’s last confession to Alice – his confession of love.

Frank’s confession was revealed as a story of the most important things in his life, spoken in his own philosophical, earthly manner. He told about the rainy day in July they had met with Alice, the marriage, Alice’s blue house, Kay’s birth and the birth of Kay’s daughters. All the happy moments came tangible to Alice as Frank led her to the drawers, one by one, which held the souvenirs of their life together. Alice was grateful of the elongated memory. There were so many things that she had forgotten, so many things buried under some ridiculous misgiving. She was also grateful that the shared chore brought her back in peace with Kay.

2. Reflection

The first objective for the SFP was to consider what motives people would have to construct their intelligent environments and what kind of configurations they would make. These objectives were considered throughout the prototype when Alice familiarized herself with the Wonderhome and her apartment, and when she interacted with the dollhouse. The multiuse environment was augmented with referenced ubiquitous computing technology for everyday activities, such as used e.g. in the Aware Home, Easy Living and iDorm [7-9]: sensing and person tracking technologies; vision techniques, sensitive floor, and voice recognition; spatial audio cues, wearable computers and unobtrusive centralized computing services. The system for finding frequently lost objects detected Fran’s silvery shoes, conceivably, with small radio-frequency tags and a long-range indoor positioning system. The smart-memo-boards were touchscreens placed strategically throughout the Wonderhome, used for presenting all the smart- and context-aware services. As a side character, the prototype introduced an electronic butler [10], the white rabbit avatar, which was an autonomous, personal agent that operated on Alice’s behalf in the virtual world [9].

The second objective of the prototype related to the storing, retrieval and sharing of personal recollections. The BeQuest drawer-chest (exploiting the Cloud of Things) and the Hologram forest (organizing the Cloud of Thoughts) exemplified innovations that could be applicable in (near or distant) future for organizing and augmenting private data and memories. The idea for the BeQuest drawer-chest came from a personal heritage cupboard and had further inspiration from a novel by Henri Bosco written in 1947 [11]. The prototype deliberately neglected to specify in detail what the technology behind the “looking-glass reader” and the “labeling” were, as in the case, the presently available magnetic and optical data storage technologies could easily be replaced, for example, by future holographic data storage technology [12]. In that case, the “looking-glass” would play more important role in creating and reading through the hologram. In essence, the drawer-chest was a computational artefact on top of which anyone can build their life stories, complemented creatively with rhymes and chords.

The hologram forest was inspired by Mark Weiser’s concluding statement in his widely quoted article [13]: “Machines that fit the human environment instead of forcing humans to enter theirs will make using a computer as refreshing as taking a

walk in the woods”. Essentially, the hologram forest was a personal map of all the digital things traceable in Alice’s life. The forest introduced a novel data visualization technique to present the ambiguous, personal digital data stored in the cloud. Another novelty was the haptic feedback and the use of gaze-contingent technique for browsing the holographic projection.

The core testimony of the prototype was that in ubiquitous world the language has enormous significance. It defines how people interact with the technology, how devices communicate between themselves, but also how the information is retrieved. Humans are successful at communicating complex ideas to each other, but there is still a lot of work to be done with the human-computer interaction. Animated characters were mentioned by Chin et al. [14] as one option for the interaction. In the home control system evaluations, the prominence of the spoken language dialogue became evident, and hence it was chosen as the key interaction mechanism in the SFP for triggering actions and subtly securing private information.

The prototype ‘Alice’s incitements in Wonderhome’ used narrative means in bridging the gap between “the unbearable lightness” of encoding ubiquitous technology and relating “heaviness” of nondeterministic users decrypting the code. It introduced enchanting technology that aging Alice would presumably be motivated to use in an intelligent nursing home. As technology becomes physical, the motivations and values, such as creativity and control [14], are fundamentally things that have the utmost importance. The quest for the IE opportunities is an on-going cycle; this SFP aimed at ending one cycle and, hopefully, provide incitements to begin another.

References

- [1] T. M. Kymäläinen, J. Heinilä, T. Tuomisto, J. C. Plomp and T. Urhema, Co-design Process and Evaluations of a Home Control System, in the Context of Intelligent Nursing Environment. In The Proceedings of 8th International Conference on Intelligent Environments (2012), 87-94.
- [2] T. M. Kymäläinen and J. C. Plomp, Life Story – Constructing a Memoir Writing Service, In Proceeding of the 16th International Academic MindTrek Conference (2012), 147-153.
- [3] Y-F. Tuan, *Topophilia: A Study of Environmental Perception, Attitudes, and Values*, Englewood Cliffs, NJ: Prentice-Hall, 1974.
- [4] E. J. Langer, *Counterclockwise: Mindful health and the power of possibility*, Ballantine Books, New York, 2009.
- [5] O. W. Sacks, *The man who mistook his wife for a hat, and other clinical tales*, Summit Books, 1985.
- [6] B. D. Johnson, *Science fiction prototyping: designing the future with science fiction*, Synthesis Lectures on Computer Science, Morgan Claypool, 2011.
- [7] C. D. Kidd, et al. *The aware home: A living laboratory for ubiquitous computing research*, Cooperative buildings. Integrating information, organizations, and architecture, Springer Berlin Heidelberg (1999), 191-198.
- [8] B. Brumitt, B. Meyers, J. Krumm, A. Kern and S. Shafer, *Easyliving: Technologies for intelligent environments*. Handheld and ubiquitous computing, Springer Berlin Heidelberg (2000), 12-29.
- [9] H. A. Hagaras, V. Callaghan, M. Colley, G. Clarke, A. Pounds-Cornish, and H. Duman, Creating an ambient-intelligence environment using embedded agents, *Intelligent Systems, IEEE*, **19** (6): (2004), 12-20.
- [10] D. J. Cook, J.C. Augusto and V. R. Jakkula, Ambient intelligence: Technologies, applications, and opportunities, *Pervasive and Mobile Computing*, **5** (4) (2009) 277-298.
- [11] H. Bosco, *Monsieur Carre-Benoît in the Country*, Staples Press Ltd., (First English Edition) 1956.
- [12] V. Sainov and E. Stoykova, *Display Holography—Status and Future*, In *Optical Imaging and Metrology: Advanced Technologies*, Wiley-VCH Verlag, Weinheim, Germany, 2012.
- [13] M. Weiser, The Computer for the Twenty-First Century, *Scientific American* **265** (3): (1991), 94–104.
- [14] J. Chin, V. Callaghan, and G. Clarke, Soft-appliances: A vision for user created networked appliances in digital homes, *Journal of Ambient Intelligence and Smart Environments*, **1**(1) (2009), 69-75.

The Programmer and the Widow: Exploring the Effects of Total Immersion in Augmented Realities

Yu HUANG^a
Hsuan-Yi WU^b

^a *University of Southern California*

^b *National Taiwan University*

Abstract. In this Science Fiction Prototype (SFP) we explore the world where augmented realities are realised through bionic lens. People live in the virtual and physical complex where total immersion brings possibilities beyond living and death. However the somewhat immortality of life does not create happiness but emotional tangle to real human beings, especially when it comes to the sense of ‘touch’. Besides from the effects, some business innovation is seen in the SFP. For example, the protagonist in this story plays an important role in the future as holographic projection programmer, which represents a new booming job in this futuristic world. They are given the power and skills to create fascinating scenarios and objects for demanders based on their requirements as if they are ‘the one’ to design and build the world.

Keywords. Science fiction prototype, immersive environment, total immersion, augmented realities, bionic lens, cloud computing, video gaming, business innovation

1. Introduction

What if one day, augmented realities blended into the real, physical world? What will be the consequences? How will people react, interact and adapt? This Science Fiction Prototyping paper will explore some issues in this area. Our story will delve into one possible future that could result from technology which blends the virtual and physical worlds.

2. Background

2.1. *Virtual World, Virtual Reality, Augmented Reality*

The focus of this Science Fiction Prototype is the creation of a virtual world that produces an augmented reality which is so immersive that people can physically live in it. Augmented reality, as defined by the Oxford English Dictionary, is “the use of technology which allows the perception of the physical world to be enhanced or modified by computer-generated stimuli perceived with the aid of special equipment.”

It is an extension of virtual reality, which the OED defines as “a notional image or environment generated by computer software, with which a user can interact realistically.” Current technology and development in augmented realities are heading in the total immersion direction, but are still far from it. The most advanced technology today use glasses to project online information in front of people’s eyes in everyday life, or have to use some type of screen for 3-dimensional projections that seem real. [1][2][3] Freestanding holograms can only be achieved on very small scales and requires a platform to project the images.¹ In the world of this SFP, a single pair of contact lenses replaces these extraneous objects.

2.2. The Bionic Lens

The technology behind this Science Fiction Prototyping is mainly based off of the concept of the Bionic Lens. The so-called “Bionic Lens” of this paper is essentially a contact lens that can project the virtual world into the physical world. The contact lens will allow users to see hologram projections that look real, aiding the believability of an augmented reality. There are several versions of this technology being researched including some that require other equipment, such as glasses, while others require an implant to function.[4][5][6][7][8] Currently, this technology is in the experimental stages and mainly used for medical purposes (such as aiding blind people or diabetic people). But once this technology goes into mass production, it can be integrated into video gaming and augmented reality experiences. The version chosen for this paper is a more advanced version of the contact lens that is directly controlled by a mobile device (such as a smartphone). In this upgraded version, the glasses part is no longer needed for the users to see the holographic image projections. In this world, a new booming job market emerges: holographic projection programmers. Holographic programmers fall into two main categories: mass production and specialized projects. Those in mass production mainly write programs for everyday items, such as clothing, accessories, plants and other “things.” Programmers in “specialized” projects will work on larger scale programs such as immersive environments (such as video games or learning environments), higher life forms (including animals and humans), and other complex systems. For those everyday things, the programs are all stored in the Cloud, with a few swipes and taps of the user’s smartphone; anyone can conjure up something from virtual reality into the real world. Because everything is stored in the Cloud, and the contacts are wirelessly operated, images and holograms that are public can be seen by everyone who wears the contacts. This creates a more realistic virtual world. Also available in this technology is the ability to record whatever the user sees (much like the Cyborg Eye in the video). Data is transmitted to the mobile device where it is then uploaded into the cloud. All footage will be secured and private, serving as “recorded memories.” Thus, in this future, one can view one’s memories almost objectively.

2.3. The Cloud

The “Cloud” is also a technology used in this Science Fiction Prototyping. The Cloud is in its emerging stages currently. In the future of this paper, it will take on a prominent, but invisible role. People will be so used to using the Cloud that they are hardly ever conscious of it and take it for granted. The Cloud will also have upgraded.

¹ The author saw this technology at Computex 2011 and asked the exhibitors about it.

It can take on massive amounts of information and offer seemingly unlimited storage space; the Cloud in the future will also be quite secure, to the point where personal data can be stored there (although to keep it realistic, there will be ways to hack into the Cloud. However, it will be much harder than hacking in the present day because of the massive amounts of data that must be sorted through). Unlike the present where there are several “Clouds” operated and managed by different companies (i.e. the iCloud, or Google Drive, etc), the future will only have one universal Cloud that everyone uses. Developed countries will all be connected through this Cloud, and underdeveloped countries will slowly begin to connect themselves to this Cloud. However, the mass usage of the Cloud will also create new jobs as more people are needed to manage the flow of data and other services related to the Cloud.

2.4. Video Games and Violence

One central theme in this SFP is the idea of the link between video gaming and violence. Some research suggests that violence in video games can leak into real life and that prolonged exposure to such video games can result in aggressive behavior in youths. [9] Presently, research is only conducted on regular 2D video games, or maybe some 3D gaming, but nothing is so immersive as a simulated game that blends into the real world as is possible with the “Bionic Lens”. This paper hypothesizes that symptoms will worsen in a world where video games emphasize total immersion. This type of immersive gaming may also result in the degradation of the value of life, as more lines are blurred between the real and the virtual. For example, when a character dies in a game, it can be brought back to life, but this is not possible in real life. [10]

2.5. The Issue of Touch

One of the biggest issues that arise in an augmented world is the issue of touch. The other senses can be more easily fooled. Sight, especially, is easy to deceive. (Indeed, many times seeing should not be believing.) Hearing, as well is easy to deceive; put on a wireless earpiece and *viola!* sound is turned on.² Smell is harder to produce in an augmented reality, but not impossible. In this future, augmented scent is possible, but cumbersome; research is in progress for more mobile ways to produce augmented scents. [11] Taste is highly related to touch, and, therefore, also a large problem. However, most people still need physical food and nutrition to survive, thus, will opt to eat real food rather than augmented food. So, although there is no real solution to the taste problem, it is mostly irrelevant in this future world. The more pressing issue is touch. No matter how real the augmented reality seems, the physical and the virtual cannot cross when it comes to touch. [12] Holograms do not have any physical substance. Therefore, one of the central issues explored in this Science Fiction Prototyping is the inability of physical (touch) interaction between the real and virtual worlds.

2.6. Of Death and Dying

Another main issue this paper will discuss is the effect of augmented reality on the

² The future of this SFP will utilize Bluetooth headsets that are available today. Sound is broadcasted through the same mobile devices that control the contact lens.

human ability to cope with death. There has not been much research done in this area because fully augmented realities are not yet available. This Science Fiction Prototyping will hypothesize one possible route or consequence.

2.7. *Minor Technologies*

This Science Fiction Prototyping also includes some minor technologies (specifically the smartscreen technology in mobile phones and wall mounts--i.e. TV) as seen in "Corning: A Day Made of Glass" (parts 1 and 2). [13][14][15] These merely aid the use of the Bionic Lens and make the future seem more realistic (since all types of technology tend to advance concurrently).

3. The Sci-Fi Prototype

3.1. *The Programmer*

"Gooooood morning everyone! What a beautiful day it is in sunny Southern California. Your headlines for today, August 8th, 2045, are: juvenile crime rates are on the rise, still; should avatar-human marriages be allowed?; new mobile scent dispersing technology in beta-testing phase at Scentsy, Inc.; and much more to come, but first, the weather."

Lotus stretched on the bed, unwillingly. She opened her eyes, then immediately shut them again. She hated the sight of her barren room without her contacts. Everything blended into a vast expanse of white. The only thing that stood out was her smartscreen television, but even it looked flat and lifeless in 2D form. Because every night, she had to take her contacts out to let her eyes breathe. She wished they would hurry up and come up with a breathable contact that didn't need to be removed ever.

Lotus clambered out of bed with her eyes closed and felt her way to the bathroom. This was her normal morning ritual. She refused to open her eyes until her contacts were in place.

"Perfect." She blinked twice and admired her image in the mirror. Without the contacts, any outsider would not have noticed a change. The Bionic Lens, as Optitech³ coined it, looked like any normal contact lens from the 20th century; no fancy colors, no pupil-enlarging effects. But put on a pair of Bionic Lens, just like Lotus, and the whole room (no, the whole world) came to life. The walls of her bathroom resembled an aquarium; 3-D fish swimming to and fro, the water was a deep, calming blue, shifting and changing in the light.

Her eyes were bright lavender, left over from yesterday's programming. And her hair is a shocking mess of purple. Only her clothes looked plain and normal. A white cami tank and a pair of black boyshorts... She hadn't programmed any fancy outfits for yesterday. In fact, Lotus still preferred real clothing. Holographic clothing just seemed insubstantial and fake. If she did program one, it was either because she had to or for special occasions only. And she would take time to make the clothes seem extra substantial. Many of her colleagues felt that programming clothing and accessories were below them, but Lotus preferred it this way.

³ A futuristic company; the company patented the Bionic Lens technology and put them into mass production for commercialization.

Lotus walked back into her bedroom where the television was still spewing out the news. This room had also changed. The walls were no longer white, but a pleasant, sunny yellow. The walls were filled with moving pictures that people only once read about in novels like *Harry Potter*. Nowadays, all you had to do was a few simple taps on your smartphone and any video footage could be projected onto your wall. The television looked different as well. It was no longer flat and 2-dimensional. The Bionic Lens added depth to the screen, making it look 3-dimensional.

"...Scentsy, Inc hopes they can receive positive feedback from their beta testing group and put these micro-scent boxes into mass production to be available for the general public by next year! Imagine! Being able to smell those roses you "plant" in your gardens...now Archy, what's the news on avatar-human marriages? Well, Blondie, the debate has been going on for a while, but this time California seems to have finally taken action. A movement out of Berkeley, California is attempting to draw up a proposition regarding this matter and possibly having it in the ballot come next election year. Wouldn't that be something? I mean I'd really like to get married one day and have some kids. People just don't respect you these days, it's like we're not real or something. Oh wait! We're not! hahahaha..."

Lotus rolled her eyes at the television. *Newscasters these days*, she thought. In fact, the entertainment industry was one of the first to embrace the Bionic Lens technology. Much of the industry's personnel had been replaced by avatars long ago. Any job that didn't require a real human was replaced with a hologram. They were just easier to control and less expensive to maintain. There was still the few novelty big name stars from the past that were human, and even a few new human stars that managed to make it in the industry, but the vast majority had moved on to the virtual world.

"...and the biggest headline for today (like every other day): juvenile crime rates are once again on the rise... (Yes, folks, imagine that! It's rising faster than our stock market)...Officials are questioning whether children are exposed to violence too young. Current legislation does not permit anyone under the age of 12 to enter total immersion arenas for gaming. However, with this new surge in child crime, officials are considering to rise the minimum age to 16. (Archy, that's outrageous! What would these children do with their spare time? I mean not all total-immersion games involve violence. This is just like last week when they wanted to raise the age for kids to get their first smartphone controller for their Bionic Lens, or the week before when they talked about raising the age for kids to GET Bionic Lens; I mean do they want our children to live in boredom and mediocrity?) Alright, Blondie, let's not get carried away here. The new surge of interest is due to last night's stabbing incident. Reports indicate that a 13-year-old boy allegedly stabbed his father to death in their L.A. home late last night. The mother has been put under protective custody and remains anonymous. The boy is currently on the run..."

Lotus muted the TV. She'd heard enough. She knew that she should care more, but she also knew that once she started caring, the cycle would become endless. It was better to just ignore these bad things, and pretend that it could never happen to her. She picked up her phone, a sleek piece of smartglass, and tapped the "work" icon.

"Name and identification, please." A disembodied female voice answered.

"Lotus, Programmer, Level 6, PXZ62945." Lotus was a specialized projects programmer. Her area of expertise was humans, and she was one of the best, having reached level 6 out of 7. Lotus put her finger on the scanner that appeared on her screen, then lifted the on-screen camera to eye-level to scan her retina.

"Identification PXZ62945 confirmed. Access authorized."

A hologram of a man immediately popped up above her phone screen.

“Oh hey, Lotus, did you see the news? New micro-scent boxes! Only in beta stage, though. I gotta get my hands on one. Imagine--”

“Hey, Weasel, do you have any work for me today?” She was not in the mood to chat.

“Oh, um...let’s see,” Weasel sounded wounded, “Na-da, you are all free today. Hey, since you got time, think we can grab lunch together? I heard this great new---”

“Thanks, Weasel, I’m busy today, maybe next time. I’ll see you later, bye!” And she hung up.

Weasel got his name because he looked like a weasel. Lotus had long forgotten what his real name was, but she was the one who started calling him “Weasel.” The name caught on fairly quickly, and now everyone called him Weasel. Lotus felt guilty for cutting him off (just like she once felt guilty for giving him this nickname), but that feeling quickly wore off as she thought about her plans for the day.

On her off days, Lotus sometimes went to work as a bartender in her friend’s club. She didn’t need the pay, but she liked the job because it allowed her to observe all types of humans. This was one of her secrets to how she could program such realistic, lifelike humans. Clubs these days weren’t like in the olden days either. Since the Bionic Lens technology caught on, time seemed less important and rigid, especially among the youths. Previously, clubs opened at night and closed around 2am, but now, anyone could program a party or a rave in their home. To be competitive, club owners changed their hours, and most clubs were opened 24/7. In her crazy teenage years, Lotus had gone into clubs and came out without realizing that she had been inside for days. There was food and drink readily available and couch beds to sleep on, not that she slept much in clubs.

Lotus tapped the screen on her phone again. Bartending required fancier clothing, so she sifted through her personal database of “Appearance” items. She chose jet-black hair for today, and blood-red eyes. Then picked out her favorite sexy-devil outfit. She was in a dark mood today. Another tap brought up a life-sized hologram of herself in the outfit she had chosen. Strictly speaking, she wasn’t supposed to program real (living or dead) humans without permission (to avoid confusion), but she hadn’t given her hologram a personality or lifelike traits; it was effectively only a mannequin. Satisfied with her choice, she projected the outfit onto herself, and closed the program for her hologram. The last step was putting in her earpiece. It *pinged* to notify her that it was connected to the Cloud. She could now hear watery sounds from her aquarium of a bathroom. She was ready to go out.

A short walk down the street brought Lotus to her friend’s club. The bouncer at the door recognized her and opened the door. She winked at him as she brushed past him. The atmosphere inside was chaotic. Lights flashed, rotated, and changed colors; music shook the entire room, briefly deafening Lotus. Even at 8am, the place was packed; of course, Lotus doubted any of them knew it was early morning. She made her way to the bar, squeezing past smelly, sweaty bodies. When she got to the bar, she noticed an odd girl sitting alone at the counter. She was clearly already drunk (who wasn’t?), but what was odd was her plainness. She was in normal, real clothes; her hair looked unkempt, and she was not having any fun. She wasn’t interacting with anyone around her; it was almost as if she was invisible, people didn’t notice her at all. Lotus ignored her, too, as she went to work behind the counter serving people drinks.

“Canigeascochpleez.” Lotus felt someone grab her arm.

“What?” she turned around. It was the drunk girl from earlier. Miraculously, she

was still sitting at the counter.

“Ca-an I git a shchoch pleeeez.” The girl repeated.

“Oh right, scotch, yes, one coming right up.” Lotus poured the drink and handed it to her. The girl grabbed her arm again as Lotus turned back to her work.

“D’chu see the neeews to-dey?” The girl hiccupped. *Oh great*, Lotus thought, *drunk girl wants to verbal vomit on me...* Lotus didn’t reply and tried to turn her back again. The girl grabbed on tighter.

“D’chu see it? Tha-at boy, d’chu see?”

“No,” Lotus lied, “I’m sorry, I have to get back to work. Miss, you’re drunk, shall I call security to take you home?”

The girl smiled at her sadly, then in a very small voice she said, “S’only pretending to be drunk.” She let go of Lotus’ arm.

Lotus’ expression softened. “Yeah, I saw the news this morning. Some boy stabbed his father to death, right? What about it?” She figured all the girls wanted were someone to talk to; she was probably just lonely.

“What about it?” the girl repeated. It was as if she was asking herself the same question. “What about it?” The girl sighed; it sounded like there was a heaviness in her heart, like the weight of the world was on her shoulders. “That boy...he was...my son. His father was my husband.”

Lotus was genuinely shocked. The girl looked barely twenty-years-old; how could she have a 13 year-old son? She saw Lotus’ surprise and said, “He was an accident, when I was 16. But his father took responsibility for his actions and married me.” On closer inspection, Lotus could see the fishtail lines on her eyes and the laugh lines at the corner of her mouth. *Yes*, she thought, *she could be about 30*.

“I’m sorry...” Lotus didn’t know what else to say.

“So am I...so am I...” her gaze wandered off, “It wasn’t his fault you know?” she suddenly perked up, as if she had to say everything at once before she lost the courage, “He’d done it before, hundreds of times. They used to play this game where they would have sword fights with hologram swords. They always ended up okay; nothing bad ever happened. It was just for fun...Even after he was allowed in the gaming arenas, he was careful to separate reality from the virtual world. This time, he only lost his temper for a second; we were in the kitchen and he just grabbed a knife, and, and--” She couldn’t continue.

“I am so sorry.” Lotus whispered. She couldn’t imagine what it was like for her.

“I tried to stop it, but I wasn’t fast enough. He didn’t mean to; he didn’t mean to...” The girl whispered over and over again. Then, she looked up at me, eyes wide and childlike. “What am I supposed to do? How am I supposed to live? Most people can’t cope with losing one person...In one night, I lost both...what am I supposed to do?” She begged Lotus with her eyes.

“I--” She didn’t know what to say, how to comfort her.

“My son, I still have hopes. He’s out there, just lost. But he’s still alive, and he still has hope. But my husband, he was so young. It’s not right; it’s not right!” Through her anguish, her tears spilled over.

Realization dawned on Lotus. Yes, her son was still alive. There was nothing Lotus could do to help him, but her husband...Lotus could program her, a hologram of her husband. Maybe it was the fumes of the alcohol, or maybe it was the chaotic atmosphere that muddled her brain, but at that moment, Lotus thought this was a great idea. So she made the girl an offer. It was an offer she came to regret later, but she had made a promise, and a promise she intended to keep.

3.2. *The Widow*

Vivienne stared out the window at the pounding rain. Actually, it wasn't so much staring *out* as staring *at* because the weather outside was sunny today. But Vivienne's heart was heavy, so she selected a projection of rain onto her window. It had been a month since Lotus had helped her program a life-size, hologram replica of her husband, Brayden. It--he--was currently sleeping in the bedroom. Vivienne couldn't sleep so she had sat at her living room bay window looking at the rain until early morning.

At first, the hologram had helped her cope. It was almost like her life returned back to normal. Maybe even better than normal because it was before her son had been born, and it was just Brayden and her, two lovebirds. Sometimes she would forget that he was only a hologram. Indeed, she wanted to forget that he was a hologram. Lotus had done a wonderful job. He looked so solid and mimicked Brayden's personality so well. They went out together, shopped together, ate together, went to the movies, amusement parks, all those things they wanted to do but couldn't because they had a child to take care of. But after a while, things started to bother Vivienne. It all began with the pasta incident. Vivienne and Brayden used to love to cook together, so naturally, Vivienne wanted to continue this tradition. Hologram Brayden couldn't help her with the real food, so they had separated into real and virtual foods, and Brayden would cook his own food, while Vivienne cooked hers. On that particular night, Vivienne had gone into the other room to change because they decided to have a romantic candlelit dinner. While she was changing she heard the pasta pot boil over. She shouted at Brayden to turn the water off because she momentarily forgot he was a hologram. When the stove continued to hiss and sizzle, Vivienne ran out to turn the heat off. Brayden stood at the stove, looking helpless, and Vivienne, in her rush, burned her finger. Brayden reached out to grab her hand in a moment of concern, but his hands only passed through her fingers without making contact. Both of them just stood there frozen like statues.

After that incident, Vivienne started to notice more and more the inconvenience of not being able to make physical contact. She even bought a human-shaped body pillow to sleep with at night. Brayden's hologram masked the pillow, and it would feel almost like she was sleeping in his arms. But the more she tried to grab onto Brayden's physical being, the more he slipped through her fingers. Today, she was brooding again.

Vivienne sighed again, as she continued to look out her window. She couldn't bear the thought of losing Brayden a second time. The first time it hurt so much. It felt like someone ripped a hole where her heart had once been. To know that pain and have to go through it again was too much. Vivienne was not going to let it happen, even if it meant taking some drastic measures. Last week, she had spent much of her time researching online the possibility of making holograms physically substantial. She called several professionals and researchers in the field, but none could give her a satisfactory response. Most told her the technology was "infeasible," some said "not yet available," and a few said "in early stages." All this basically sounded like she was running out of options. Try as she might, she could not touch Brayden ever again. She wasn't sure this was a sacrifice she could live with. Her friends had said her personality changed. She was more irritable and paranoid. Every time one of them got close to Brayden, she would freak out. And not being able to make physical contact with his hologram became an everyday reminder of that gaping hole in her heart. It was like the hole had been filled quicksand rather than something solid.

Vivienne took out her phone. She selected a range of memories from before

Brayden's death, and projected them onto the window. Their summer trip to Hawaii, her 15th birthday, their last Valentine's Day together... Vivienne doubled over in pain all of a sudden, arms hugging herself tightly, as if trying to hold herself together or to hug away the hole in her heart...

4. Summary

This Science Fiction Prototyping posits some interesting questions regarding total immersion augmented reality. First, it described the world in which augmented realities blend into physical realities and some possible reactions of humans as a result. We hypothesize that although people are aware of the many negative side effects of this technology, they will have become so addicted that, as a society, people are not willing to discontinue its usage. In fact, most people will chose to ignore the signs because the technology has become too much a part of their lives. It also explored possible consequences of total-immersion gaming on youth. When the line between virtual and reality becomes blurred, people can have a hard time distinguishing between the two. Also, as a result, people may not be able to clearly see the full impact of their actions, leading them to perform regretful acts.

The second part of this Science Fiction Prototyping explores the two other issues that may arise in this futuristic world: integration of touch and psychology of death in augmented realities. We postulate that touch will be one of the hardest senses to integrate into augmented realities, and that it will be the one area of imperfection in a blended world. We speculate that the psychology of death will also take on some changes in the future. As technology advances, people will be most focused on how it can prevent death. But we wanted to explore the "what if's" of death. Can augmented realities help victims cope with death? Or will it just delay and worsen the initial symptoms? Although this paper does not offer any clear answers, we hope that it will urge people to start thinking about these issues. Maybe, just maybe, we can come up with solutions before it is these types of technologies take hold.

Acknowledgements

We acknowledge Prof. Jong-Tsong Chiang for his openness and encouragement to students in class. Thank to Hsuan-Yi Wu who brought this interesting method SFP to the class so that the first author had the chance to explore and complete this story in the summer of 2012.

References

- [1] Total Immersion, "*What is Augmented Reality?*", 2013, [online] Available at <http://www.totalimmersion.com/augmented-reality/what-augmented-reality> [Accessed 24 March 2013]
- [2] P. Rutledge, "*Augmented Reality: Real Life with Toppings*", 19 May 2010, [online] Available at <http://www.psychologytoday.com/blog/positively-media/201005/augmented-reality-real-life-toppings> [Accessed 24 March 2013]
- [3] J. Sloan, "*What Life Will Really Be Like Wearing Google's Augmented Reality Glasses*", 5 April 2012, [online] Available at <http://www.disinfo.com/2012/04/what-life-will-really-be-like-with-googles-augmented-reality-glasses/> [Accessed 24 March 2013]
- [4] C. Dillow, "DARPA Invests In Megapixel Augmented-Reality Contact Lenses", 02. 01. 2012, [online] Available at <http://www.popsci.com/technology/article/2012-02/video-nano-enhanced-contact-lens-makes-augmented-reality-more-realistic> [Accessed 24 March 2013]

- [5] Susanna55 "[Bionic Contact Lenses – The world before your eyes](#)", 20 February 2012, [online] Available at http://www.sony.co.uk/discussions/community/en/community/better_futures/how_you_can_help/blog/1839 [Accessed 24 March 2013]
- [6] Sally James, "[Big Step Forward for Safety of Bionic Contact Lenses](#)", 15 Feb 2012, [online] Available at <http://www.popularmechanics.co.za/article/big-step-forward-for-safety-of-bionic-contact-lenses-2012-02-15> [Accessed 24 March 2013]
- [7] ITN News, "[Man sees with bionic eye](#)", 26 Aug 2011, [online] Available at <http://www.youtube.com/watch?v=2qPWc32LS8> [Accessed 24 March 2013]
- [8] "[Bionic Eye](#)", [online] Available at <http://www.youtube.com/watch?v=y0apm2NnNx8> [Accessed 24 March 2013]
- [9] Christopher J. Ferguson, "[Video Games and Youth Violence: A Prospective Analysis in Adolescents](#)", *Journal of Youth and Adolescence*, April 2011, Volume 40, Issue 4, pp 377-391, [online] Available at <http://www.springerlink.com/content/0m182577967qu617/fulltext.html> [Accessed 24 March 2013]
- [10] Science Clarified, "[Chapter 6: Which World is Real? The Future of Virtual Reality](#)", 2013, [online] Available at <http://www.scienceclarified.com/scitech/Virtual-Reality/Which-World-Is-Real-The-Future-of-Virtual-Reality.html#b> [Accessed 24 March 2013]
- [11] Manisha Laloo "[Making smell-o-vision a reality using a polymer matrix](#)", 21 June 2011, [online] Available at <http://www.rsc.org/chemistryworld/News/2011/June/21061101.asp> [Accessed 24 March 2013]
- [12] John Suler, "[The Final Showdown Between In-Person and Cyberspace Relationships](#)", May 1997, [online] Available at <http://users.rider.edu/~suler/psycyber/showdown.html> [Accessed 24 March 2013]
- [13] Corning Incorporated, "[A Day Made of Glass... Made possible by Corning. \(2011\)](#)", 2011, [online] Available at http://www.youtube.com/watch?v=6Cf7IL_eZ38 [Accessed 24 March 2013]
- [14] Corning Incorporated, "[A Day Made of Glass 2: Same Day. Expanded Corning Vision \(2012\)](#)", 2012, [online] Available at <http://www.youtube.com/watch?v=jZkHpNnXLB0> [Accessed 24 March 2013]
- [15] Corning Incorporated, "[A Day Made of Glass 2: Unpacked. The Story Behind Corning's Vision. \(2012\)](#)", 2012, [online] Available at http://www.youtube.com/watch?v=X-GXO_urMow [Accessed 24 March 2013]

Talking Things

Yevgeniya KOVALCHUK
King's College London, UK

Abstract. Have you ever wished to know and actually feel what your friends feel so you could help them better? Or maybe you have wondered how it is to be one of those celebrities you admire? And how about to become an apple for example? To experience lazy days of hanging on a tree enjoying sunshine and being washed by rains? Or maybe it feels the opposite – a hard life of fighting against worms, decay, and poor weather conditions? What is that thing that makes us feel ourselves and being aware of the boundaries of our body? Can an iPhone we hold in our hands become a part of our body image? Can its processor unit become part of our brain, while various sensors embedded into it become part of our nervous system? So what if so you wonder? An answer follows.

Keywords. Human-machine interfaces, neuroengineering, implants, sensors, multisensory integration, 'rubber hand illusion', provenance, security.

Introduction

Every manufactured product could be equipped with an embedded processing unit and memory to routinely record and store contextual information of the products use. Similarly to humans, physical objects that surround us and services we receive would then be able to speak for themselves, socialize, create communities, exchange knowledge and pass it to their descendants by way of upgrades, and thus develop and evolve. Based on the many discussions of the 'Internet of Things' and how robots could go beyond our control [1], this paper further explores the relationship and boundaries between artificial and natural intelligence and how current scientific discoveries about human nature (from studies in neuroscience, medicine and psychology) could inform future technological innovation.

More specifically, this paper looks at the possibility of our connection to external (beyond our biological brain) processing units, extending this way our personal self beyond our physical body and consciousness. Furthermore, the paper questions what happens to the 'here and now', when we connect and bring personal memories and memories of the Things from the past into the present moment?

Why would we need this? One quick practical example – wouldn't it be nice if the common knowledge becomes part of our conscious instead of us spending many boring hours finding relevant information and then maybe having some tough times studying it? But read the story to find out more. Spinning out of the recent scientific research, this science fiction prototype blurs the boundaries between internal and external, natural and artificial, present and past.

1. Research underpinning the story

Smaller processing units, electronic memories of larger capacity, and a wider range of available sensors make it possible for humans to sense, store, and process more signals. This is our way to understand (or control?) the physical world. Using various instruments, we can see and hear things with different physical qualities inside our body, deep under water and the land, high in the sky. Such instruments may come in the form of standalone external devices (microphones, telescopes, microscopes, etc.), or wearable gadgets (smart clothes, Google glasses, etc.), or they can be attached directly to our nervous system or tissues, thus extending our natural sensory system and allowing us to connect to other biological systems or control electronic devices remotely. Examples of the later technology include the ‘bionic ear’ developed by Princeton scientists [2], neuronal and magnetic implants developed by Professor Kevin Warwick and his student at the University of Reading [3 - 6], and a number of recent neuroengineering tools for brain-computer interfaces and neuroprosthetic implants [7 - 10].

Extension of our conscious experiences may be soon achieved not only in the spatial dimension, but also in time. Technologies such as Evernote [11] may allow us to experience past events in the present moment as if they were real.

The above examples raise the question of what and where our conscious will be in the future as we experiment with our mind and the nervous system by injecting the artificial into biological and designing devices to enhance our mental and physical abilities. What will happen to our perception of the self and boundaries of our body?

A number of recent studies suggest that multisensory integration plays an important role when the brain needs to distinguish “between parts of one’s own body and objects in the external world” [12]. The ‘rubber hand illusion’ reported first by Botvinick and Cohen in 1998 [13] is now the subject of many different experiments and studies carried out by psychologists and cognitive neuroscientists alike [14 - 16] in an attempt to answer the philosophical questions of “How do we come to feel that we own our body? What is the relationship between our body and our sense of self?” [12]. The ‘rubber hand illusion’ is “a perceptual phenomenon whereby tactile sensations are referred to an alien limb as a result of the interaction between vision, touch, and proprioception” [15]. While the original experiments were carried out with an artificial (rubber) hand, some later studies have demonstrated that external real objects (that look not like a hand) could also be perceived by us as part of our body image [16], as could phantom limbs [17].

Many applications of these findings have already been tested, ranging from advanced hand prostheses [18], through manipulation of pain perception [19], to virtual reality and simulated environments [20, 21]. Such studies not only blur the boundaries between natural and artificial, virtual and real, the body and its environment, but also open doors for possibilities to explain various types of transformations that are currently considered to be mysterious. For example, we already know that a guitar can be made to sound like a piano and any voice can be made to sound like someone else’s [22]. But we don’t yet consider it is possible to turn into another person and actually consciously become that person.

Regardless of how far we stretch our imagination, extend boundaries of the body or advance transformations, the eternal question remains the same: What is the original? Would a provenance infrastructure [23] allow us to know for sure that a source is genuine and what its origin is? Even if we assume that ‘the free will’ (which

from the neuroscience perspective may be considered as our ability to intentionally inhibit our voluntary actions [24]) is the feature that distinguishes us from robots [25], are we still in control, can we still maintain the balance? How emotional relates to physical? How natural relates to artificial? The more interfaces we develop, the more opportunities for flaws we create [26].

In my research, I have explored capabilities of brain-computer interfaces to find and justify complex connection between our physical and mental states [27], proposed a model for maintaining homeostasis (balance) in biological organisms [28], and contributed to the development of the ICmetrics technology [28 - 31] – the technology of generating unique identifiers that may serve as encryption keys directly from characteristics of electronic systems' behaviour (to ensure security and safety of human-machine interfaces for example). These are some of the important aspects involved in devising technology that may advance human performance and capabilities. There are however many other issues to consider if we want to extend our consciousness beyond our physical self. The following science fiction story is designed to highlight some of these problems and suggest possible solutions to them.

2. The fictional story

2.1. Preface: Cabbage

Once upon a time, there were four Kingdoms, all lying around a big Cabbage, but nevertheless not being aware of each other. The habitants from the first Kingdom were routinely attaching new leaves to the Cabbage due to observed shrinkage which they believed was a natural process beyond their control. The habitants from the second kingdom were routinely removing leaves from the Cabbage as they saw it expanded which they believed was a natural process beyond their control. The habitants from the third kingdom were routinely both adding and removing Cabbage's leaves depending on its size which they believed changed naturally and had no control over. The habitants from the fourth kingdom were routinely adding what they believed were good leaves and removed what they believed were bad leaves. They thought they were in control of the process. They were all wrong. The Cabbage didn't care. It believed all the changes occurring to it happened naturally.

2.2. A bump on a road

“Meditate, eat a red apple and one egg, put on the orange tie with penguins” – Paul read on the screen of his iPhone. “OK, let's see how far we go with this today” – he thought, scrambling himself from the bed and heading to the bathroom. He removed the usual morning routine from the program not to clutter the screen. Apparently he could do the same for his morning meditations which also seemed to be set as a constant for his profile. Where things started to deviate slightly from the script was the recommended breakfast and by the time the day was nearly done and bed was in reach again, his actual path seemed to have nothing in common with the original plan set out for him. All attempts to figure out why, when and where deviations were happening hadn't led him any further forward only to use “the fortune” excuse.

After reading somewhere about scientific research suggesting that a key for well-being is to keep balance (which in this case meant to load all brain regions evenly throughout the day), Paul bought an app suggesting alternative activities for each brain region and making recommendations for his life based on his profile and actual everyday activities. Consequently Paul would perform a brain scan at the end of each day and map it to the daily log of completed activities and those scheduled for tomorrow. The app would then suggest him what to eat and wear the following day along with a list of recommended alternative activities.

It never worked for him.

But he guessed there were people out there who benefited from the tool, otherwise it wouldn't be so popular. Maybe the app was designed by or for 'tanks'. Paul liked to think of life as driving with different vehicles on the road (bicycles, motorbikes, cars, buses, lorries, trams, etc.). Drivers start from somewhere, they might have a destination point in mind (or not), a map, and a navigator to guide them through. They might even be aware of road closures, diversions, road works, and trace accidents in real time. But Paul was convinced only the power of a higher divine could determine the minds of other road users, what happens in their little 'car' world, and how they react to unexpected events (created by the very same road users). Some (whom he called 'tanks') would go forward no matter what, 'removing' anything obstructing their path. Others would get angry and stressed creating even more mess. Yet others would relax and enjoy the opportunity to deviate and discover new routes. Paul preferred not to rush. He noticed many times that those in a hurry would have to wait for those behind anyway.

He wondered though, what would happen if 'traffic lights' enforced by authorities were removed; how big would the gap between people become? At the same time, the strongest force that keeps people from flying are their own habits. The longer a man lives, the deeper his roots go into the ground. Paul had lived long enough not to be able to keep up with all the innovation, most of which he thought was unnecessary. He still did multiplication on paper, when his children used calculators. He still made notes by hand, when his grand children typed on a computer. He still read paperback books, when nowadays any mobile device could read out loud an electronic version of it.

Old skills die, new emerge. Paul loved the analogy of adding and removing leaves from a cabbage. They call it neuroplasticity. He wondered what man's brain would be in future times when there is no need for people to read, write, calculate or even reason. Now his new app was suggesting him what to do today. It is a navigator. "No way will I take the back seat!" – Paul encouraged himself for the day.

He scanned the apple. Another gadget he considered to be a waste of money – real time food scanner which tells you the actual nutritional content of the item along with the (long) history of its origin and actual path (he loved the sound of the word 'provenance' though). Some fruit even had a video camera, shock and heat sensors so the fruits life from birth to consumption could be shared. The paradigm "from the farmer directly to your table" seemed to be from the genre of fantasy. He wished he hadn't used the scanner this morning either, since now he had to swallow a tasteless multivitamin tablet as the poor red thing appeared to be virtually free from anything except the various nasty chemicals it was washed in.

"OK, the orange tie with penguins... ha-ha" – Paul knew where that instruction came from. Of course, it was Tuesday, meaning the dreaded meeting with the bore of a boss was today. Normally, Paul would follow any such 'Tuesday' advice as it always proved to be fun; but not today. It was one of those mysterious indescribable feelings,

as if someone was adding something to his glass while he was not watching. He ‘knew’ something would ‘happen’ today.

Failing on two things today so far (the apple and the tie), Paul set himself off to work to witness once again how his personal nature and those of other road users would ruin another perfectly designed day intended to keep him fit and healthy. Well, he did make an attempt to correct himself by playing a tune from the collection “Cheer me up” on leaving the house. That was the trick he usually used and sometimes it actually worked. He sorted various artifacts according to the effect they seem to make on him. He always had quick fixes for any situation. Whatever was the task in front and whatever was his mood and physical state right now, there was always a treat in his collection bridging the two. From boring to funny, from tired to energized, from depressed to enthusiastic – not a problem for him.

It was a problem for him however to manage his physical health. Sudden headaches started to bother him recently. Neither he nor doctors could think of a particular reason. The attack happened again; the pain was unbearable strong this time.

No one, except one guy, paid attention to a man falling unconscious on a street bench; drunken people were the norm in this area.

2.3. A day of a courier

Paul worked as a courier. Not like a courier in those old days when you collected a box from the delivery depot and transport it to the address printed on the label. No. Today all things could speak for themselves and have attitude. He loved it in a way; at least someone to talk to. So, the thing would tell him how to be treated and where to be delivered. Those from his higher management also had access to the thing’s memory telling its history (to prevent crime so they say).

Recently however, some new suspicious parcels (actually boxes constructed from an unknown material) started to appear at the depot. No one knew where they were coming from and what was inside. They had no delivery address labels and they were packed in such a way that no one could open them. The rumour was that even higher managers didn’t know the provenance of the boxes; the boxes had no memories.

First, the boxes were kept in a storage room, while investigation into their origin was going on. They kept coming however, and managers started to worry where to find a space for them (they were afraid to destroy the boxes for political reasons). The worry was unnecessary though. Something strange was going on; despite adding the boxes to the storage room, it never became full. So far.

The most worrying thing for Paul however was the feeling that he had seen those boxes somewhere previously.

2.4. Knowledge essence in a probe

- Who are you? – Paul stared at the guy. – Where am I? – Paul couldn’t recognise the room.
- Hi, I’m Roger, you are in my house; you fell unconscious on the street, so I brought you here.

- Me? Unconscious? – Paul couldn't believe it. – Ah, that must be the headache attack had finally got me. Thank you very much for rescuing me, what I can do for you in return? Do you want money? What time is it now? I need to get to work!
- It is half past nine; you have only been here for an hour.
- Oh my god! I'm already late for the meeting with my boss at ten. Where exactly is this place, I might take a taxi?
- I'm sure your boss can wait; you are still too weak to travel.
- You don't know him, he will kill me!
- Your illness will kill you sooner. Where do you work?
- In a bank. How do you know about my illness? Do you know what it is?
- Not quite yet, but I believe we could figure that out.
- What do you mean not quite as if you know something about it? And how can we identify the disease? – Paul was lost somewhere between the urge to leave for the meeting and his curiosity about the man and the situation. He wanted to know what was going on with him recently, where those headaches were coming from.
- You told me some facts about your illness, and I believe we can get more details if you follow me.
- Have we met before? You said I had been unconscious, how could I tell you anything?
- Well, not you explicitly, but your experience of being a cell that delivers nutrients.
- What? – Paul was confused. “What should I do, this man seemed quite mad” – he thought.
- Let me explain. I am a scientist; I designed an interface which allows you to become or ‘tap’ into an external thing. I call it the Tap Machine. With it, you could consciously become aware of someone else's (or personal but from a different perspective) experiences, knowledge, and memories. I could have called an emergency when I saw you on the bench unconscious, but I thought that was a great opportunity to test my machine outside the laboratory and for a good cause. I brought you here in a car, and as you were not aware of your body at that time, the transition of your consciousness to the level of a cell was smooth. I didn't know where to start and had already considered the possibilities of self diagnosis by means of blood cell becoming. From my previous travels I had an understanding that we may lose consciousness if supply of oxygen or nutrients is restricted to the brain... – Roger stopped for a moment. – You can call the police now, but I don't think they will believe you, I don't hold you, and you are rescued at the end of the day.
- I don't think I quite understand you. Do you mean I can become this fly and feel like it? – Paul's eyes followed an insect flying in the room. – Or become you for example? – he looked into Roger's eyes.
- Yes, exactly. I know a bit about your health problem because I set you to become your own blood cell and recorded your memory and experience as a cell within your body.
- A cell? I am my cell?
- Please don't worry, and don't shout. No, you are not your cell now, now you are you. This is still only a prototype, but it looks promising. I need to do a couple more experiments to make sure everything is working. Could you help me please? I could test the Machine on you, we may then find the cause of your headaches and hopefully fix it.
- I am not a laboratory mice, sorry. What if this thing kills me?

- I will repeat; your illness may kill you soon anyway. I am not claiming anything of course, and choice is yours, but I personally wouldn't ignore those headaches.
- I haven't, I have consulted with doctors!
- And what? Have they got an answer what it is and found you a treatment? Apparently not, otherwise you wouldn't have fallen unconscious in the street. Why do you think they will help you in the future?
- Just hoping. – Paul really didn't know what to do. It all happened so unexpectedly. He needed to think about it, and this man, whoever he was, was putting pressure on him.
- Paul, what are you living for? To satisfy your boss? Or to ride yet another road because your main one has been closed? I, for example, want to make a thing that will help others, so less people suffer from headaches and other diseases. We all come and go, what remains is our product. Please help me to leave a useful product. I know you want to feel secure, but always staying in the middle of the see-saw won't make you any different tomorrow, or after tomorrow, or until you die. Let's move to the edges and fly higher to see further. You know the game, you'll be back to earth, nothing to worry about. I promise I will be here for you to get you safely to the ground.
- Your see-saw analogy reminded me my childhood. You are right in a way; I haven't progressed much since then. Still write by hand... Maybe it's time to get my hands on the 'new technology'; oh, I hate it!
- Do you remember much about your childhood? As this is exactly what I have in mind for our next experiment. I was wondering about those boxes you seem to remember as a cell. Boxes and the delivery depot were just my graphical interface to represent the actual data. As far as I could see from the log, there is a suspicious substance circulating and accumulating in your body. Neither your body nor medics could recognise it. But some of your cells seem to remember it from the past. I tapped into the aggregated knowledge of recognised physiologists and psychologists alike and many seem to agree that some diseases we develop as adults are caused by problems we had as children, despite whether it is mental, emotional or physical problems. It makes sense in a way as we are basically a collection of everything that we and others have been putting into us since our birth: the environment, people, media, adverts... who knows which transformations and reactions may happen between them as we add more and more.
- Are you saying you consciously experienced what doctors of all times knew?
- And yes and no. Of course I wouldn't have time to live each one of their lives (although I could if I wished), but I have designed an algorithm which extracts a summary of only distinct, significant events and discoveries, so I tapped into their aggregated knowledge and experiences. In a way, I was a fusion of the essences of the knowledge of all recognised experts in the field.
- Incredible, you could rule the world if you knew everything!
- I wouldn't be me if I was them and would become insane if I knew everything. I have discovered that lots of information is repetitive, despite it can be presented in different forms to hide similarities. There is also lots of rubbish out there. As I said earlier, similar to plants we are like sponges that absorb anything we come across, even if not recognising this. You might have tasted different tomatoes for example. Some tomatoes grow surrounded by farmers' love, under the sun, in a fertile soil, others accumulate tones of pesticides. Some are juicy and sweet. Others are more sour, bitter or watery. Yet others are tasteless.

- But you can get only the best, can't you?
- Well, the problem is how to identify the best and unique. We all have different preferences and certain knowledge and experiences might be not good for us. If you get used to sour tomatoes, you won't necessarily like the sweet ones, and high sugar content might be not a good idea if you have diabetes.
- Your invention would seem to be very dangerous: I could likely kill myself if tapping into a wrong source, equally I wouldn't be happy to know that someone is tapping into me, in other words becomes me.
- I totally agree, there is a lot to consider and many years will pass until regulatory institutions are established and the public warms up to the new possibilities. So far, this is just a laboratory prototype. I use it only to tap into the knowledge and archives that are publically available. Tapping should be only permitted with the owner's permission, whether it's their material or intellectual property, or indeed their biological (or not fully so) body. Would you give me such permission? We could of course arrange things formally, if you wish, but it will delay the experiment which you may not afford providing your situation. I will leave it up to you to consider all risks and decide.
- OK, I think I am impressed with your imagination enough to continue the journey. I am late for the meeting with my boss anyway, so doesn't matter much who or what will kill me first, him, my illness, or your machine.

2.5. The past saves future

Paul received the same vaccine as all other children in the nursery he attended. It was designed to protect him from a disease going around at the time. The vaccine did its job; Paul didn't get sick at the time. However, a microorganism included in a vaccine became a food for other bad bacteria in Paul's body. No one reported the side effect, and no one recognised the problem with Paul. His immune system was strong enough to kill the bad bacteria. Unfortunately, an emotional distress occurred later in his childhood, causing a hormonal imbalance which weakened the immune system. The mass of bad bacteria started to grow whenever Paul had hard times as an adult. The bacteria didn't show up in a few laboratory tests Paul took; the immune system was still fighting. But every stress promoted reproduction of the bacteria and their mass became critical. The bacteria could win the battle against the immune system at any moment.

With the help of the Tap Machine, Paul was able to recognise the dangerous situation within his body. By becoming aware of the experiences of his own blood cell, he learned about the bacteria (the suspicious boxes as designed by Roger in the graphical interface of the Tap Machine) and their origin. Paul of course didn't remember all the details from his childhood and couldn't make connections between the events. Only with the help of the Tap Machine could he live his childhood again and relate past events to the present moment.

Paul requested one more laboratory test despite the last saying he was in the clear. The doctors were shocked to find this new condition. But fortunately it wasn't too late and Paul received the treatment he needed in time. The Tap Machine saved his life. Will it save other lives? Will we be able to use the technology wisely?

3. Summary

The science fiction story presented in this paper explored the possibility and consequences of our ability connecting to external things and memories extending in that way our physical body, mind, and consciousness beyond our biological system. As opposed to the idea of extending and expanding our sensory system through inclusion of external sensors to continuously sense more, this paper suggests to tap into additional modalities and sources only when and is required. This could be a need for artificial limbs (a technology that already exists) or for conscious awareness of the human common knowledge and personal history; not as we remember it, but how it actually happened.

We have developed ways to preserve records electronically. Can means be found to include it into our conscious perception of self? The story demonstrated it could be a useful technology to the extent that it can save lives. But would it always be safe and how much information are we ready or can digest?

Evolution can be seen as a process of shifting boundaries. It is down to the human's perception of where the boundaries are. Our picture of the world is changing all the time, with the focus ruled by current trends in science. The problem is that scientists can only glimpse a portion of data that can be extrapolated from world we live in. As our data-rich environment supplies more at an ever increasing rate, the task of selection to solve a problem in a meaningful way becomes far more difficult. It doesn't really matter what is available or exists, but rather what we are tuning for. The information retrieval community may need to develop revolutionary new search algorithms as more (unusual) sources become available to us.

References

- [1] P. McCullagh, Internet of Mysterious Things, *Workshop Proceedings of the 7th International Conference on Intelligent Environments*, IOS Press, 2011, 255-267.
- [2] M. S. Mannoor, Z. Jiang, T. James, Y. L. Kong, K. A. Malatesta, W. O. Soboyejo, N. V., D. H. Gracias, and M. C. McAlpine, 3D Printed Bionic Ears, May 1, 2013, <http://pubs.acs.org/doi/abs/10.1021/nl4007744>
- [3] J. Hamed, I. Harrison, M. N. Gasson, K. Warwick, A novel human-machine interface using subdermal magnetic implants, *Proc. IEEE 9th International Conference on Cybernetic Intelligent Systems (CIS)*, 2010.
- [4] K. Warwick, Linking human and machine brains, *Proc. IEEE International Conference Engineering Intelligent Systems*, 2006, 1-6.
- [5] K. Warwick, M. Gasson, B. Hutt, I. Goodhew, K. Kyberd, H. Schulzrinne, X. Wu, Thought Communication and Control: A First Step using Radiotelegraphy, *IEE Proceedings-Communications* **151** (2004).
- [6] K. Warwick, M. Gasson, B. Hutt, I. Goodhew, An attempt to extend human sensory capabilities by means of implant technology, *International Journal of Human Computer Interaction* **17** (2004).
- [7] R. M. Rothschild, Neuroengineering tools/applications for bidirectional interfaces, brain-computer interfaces (BCIs), and neuroprosthetic implants – a review of recent progress, *Frontiers in Neuroengineering* **3** (2010).
- [8] A. Al-armaghany, B. Yu, T. Mak, K.-F. Tong, and Y. Sun, Feasibility Study for Future Implantable Neural-Silicon Interface Devices, *33rd Annual International Conference of the IEEE EMBS*, 2011.
- [9] T. W. Berger, R. E. Hampson, D. Song, A. Goonawardena, V. Z. Marmarelis, and S. A. Deadwyler, A cortical neural prosthesis for restoring and enhancing memory, *Journal of Neural Engineering* **8** (2011).
- [10] T/ W. Berger, J. J. Granacki, V. Z. Marmarelis, A. R. Tanguay, S. A. Deadwyler, G. A. Gerhardt, Implantable Biomimetic Electronics as Neural Prostheses for Lost Cognitive Function, *Proceedings of International Joint Conference on Neural Networks*, 2005.

- [11] C. B. Myers, The Future of Evernote: From memory machine to time machine, 10 September 2011, Download from: <http://thenextweb.com/insider/2011/09/10/the-future-of-evernote-from-memory-machine-to-time-machine/>
- [12] H.H. Ehrsson, The Concept of Body Ownership and its Relation to Multisensory Integration, *MIT Handbook of Multisensory Integration*, Boston, USA: MIT Press, 2010.
- [13] M. Botvinick and J. Cohen, Rubber hands 'feel' touch that eyes see, *Nature*, **391** (1998), 756.
- [14] T. Asai, Z. Mao, E. Sugimori, and Y. Tanno, Rubber hand illusion, empathy, and schizotypal experiences in terms of self-other representations, *Consciousness and Cognition* **20**, (2011), 1744-1750.
- [15] D. M. Lloyd, Spatial limits on referred touch to an alien limb may reflect boundaries of visuo-tactile peripersonal space surrounding the hand, *Brain and Cognition* **64**(1) (2007), 104–109.
- [16] N.P. Holmes, G.A. Calvert, C. Spence, Extending or projecting peripersonal space with tools? Multisensory interactions highlight only the distal and proximal ends of tools, *Neuroscience Letters* **372** (2004), 62–67.
- [17] M.R. Longo, C. Long, and P. Haggard, Mapping the invisible hand: a body model of a phantom limb, *Psychological Science* (2012), ISSN 0956-7976. (In Press), Downloaded from: <http://eprints.bbk.ac.uk/4592/>
- [18] B. Rosén, H. H. Ehrsson, C. Antfolk, C. Cipriani, F. Sebelius, and G. Lundborg, Referral of sensation to an advanced humanoid robotic hand prosthesis, *Scandinavian Journal of Plastic and Reconstructive Surgery and Hand Surgery* **43** (2009), 260–266.
- [19] M. R. Longo, V. Betti, S.M. Aglioti, and P. Haggard, Visually induced analgesia: seeing the body reduces pain, *Journal of Neuroscience* **29** (2009), 12125–12130.
- [20] M. Slater, D. Perez-Marcos, H. Ehrsson, and M. V. Sanchez-Vives, Inducing illusory ownership of a virtual body, *Frontiers in Human Neuroscience* **3** (2009), 214–220.
- [21] M. Slater, D. Perez-Marcos, H. H. Ehrsson, and M. V. Sanchez-Vives, Towards a digital body: the virtual arm illusion, *Frontiers in Human Neuroscience* **2** (2008), 6.
- [22] D. Gibson, *The Art of Mixing: A Visual Guide to Recording, Engineering and Production*, 2005.
- [23] M. Simon, S. Munroe, M. Luck, L. Moreau, Modelling the provenance of data in autonomous systems, *Proceedings of the 6th international joint conference on Autonomous agents and multiagent systems*, May 14–18, 2007.
- [24] E. Walsh, S. Kühn, M. Brass, D. Wenke, P. Haggard, EEG activations during intentional inhibition of voluntary action: an electrophysiological correlate of selfcontrol, *Neuropsychologia* **48** (2010), 619–626.
- [25] B. D. Johnson, *Science Fiction Prototyping: A Framework for Design*, Synthesis Lectures on Computer Science Series, 2011.
- [26] Y. Kovalchuk, The Ministry of Interfaces (Doors), *Workshop Proceedings of the 7th International Conference on Intelligent Environments*, IOS Press, 2011.
- [27] Y. Kovalchuk, Scientific Theatre: Multidisciplinary Approach to Designing Intelligent Environments, *Workshop Proceedings of the 7th International Conference on Intelligent Environments*, IOS Press, 2011.
- [28] Y. Kovalchuk, V. Callaghan, A Self-Organizing System for Online Maintenance of a Living Organism, *6th International conference on Intelligent Environments*, 2010, 283-288.
- [29] Y. Kovalchuk, W.G.J Howells, H. Hu, D. Gu, K.D. McDonald-Maier, A practical proposal for ensuring the provenance of hardware devices and their safe operation, *Proceedings of the IET System Safety Conference*, 2012.
- [30] Y. Kovalchuk, W.G.J Howells, H. Hu, D. Gu, K.D. McDonald-Maier, ICmetrics for Low Resource Embedded Systems, *Proceedings of the third International Conference on Emerging Security Technologies*, 2012.
- [31] Y. Kovalchuk, D. Newman, W.G.J Howells, S. Kelly, H. Hu, D. Gu, K.D. McDonald-Maier, Investigation of Properties of ICmetrics Features, *Proceedings of the third International Conference on Emerging Security Technologies*, 2012.
- [32] Y. Kovalchuk, G. Howells, and K.D. McDonald-Maier, Overview of ICmetrics Technology – Security Infrastructure for Autonomous and Intelligent Healthcare System, *International Journal of u- and e-Service, Science and Technology* **4** (3) (2011) 49-60.

An Introduction to Genetic Profiling

Marc DAVIES¹ and Vic CALLAGHAN

Intelligent Environments Group, University of Essex, Colchester, UK

Abstract. This paper highlights the latest stage of an ongoing research project, primarily focussing on generating artificial anthropomorphic behaviour-sets for computer-generated non-player characters (NPCs). Building upon work presented in previous papers, this research highlights the latest results obtained from an investigation evaluating the anthropomorphism, (i.e. human-likeness) of several computer-controlled synthetic humans, controlled using artificial behaviour-sets generated by a new Artificial Intelligence mechanism, 'Genetic Profiling'. In addition to providing an introduction to the new mechanism, this research also serves to highlight how Genetic Profiling can potentially be applied to investigative scenarios in Computer Science projects outside the recreational games related context largely used by this project.

Keywords. NPC Behaviour, iWorlds, Mimicry, Evolutionary Algorithms, Intelligent Environments.

Introduction

It can be argued that one of the ultimate destinations of Computer Science will be to someday produce a system capable of replicating a human level of intelligence. For now that feat still resides firmly within the realm of science-fiction and this project has no intention of trying to change the status quo. The ultimate goal of this project was to attempt to create an alternative mechanism that could potentially act as an interim until the development of the ultimate human-level Artificial Intelligence system. The desire was to let computer-controlled Non-Player Characters (NPCs) exhibit decision-making and action patterns resembling performances demonstrated by real people in similar situations. Although other Artificial Intelligence mechanisms already exist for such purposes, the performances they produce often lack realistic anthropomorphic behavioural patterns. This is especially an issue for computer games, where poor controller Artificial Intelligence can result in NPCs performing stupid actions, which in turn can potentially ruin the enjoyment and immersive properties perceived by the players. Consequently, a new Artificial Intelligence mechanism, (UK Patent Application No. 1012243.0), combining elements of Mimicry and a modified form of Genetic Programming, was introduced by this project. Dubbed 'Genetic Profiling', the purpose of the mechanism was to take pre-recorded performances demonstrated by real people and recombine the stored decision-making and action data into multiple novel behaviour-sets. Artificial behaviour-sets generated by the new mechanism could then be used in controller software for NPCs, which may be represented in an environment by some form of avatar, or alternatively adopt a more agent-like omnipresence.

¹ Corresponding Author: midavi@essex.ac.uk

The research performed by this project has largely focussed on the NPCs commonly found in computer games and other recreational virtual worlds. However, artificial behaviour-sets generated by Genetic Profiling mechanism could also potentially be applied to other areas of Computer Science. For example, in research projects involving Intelligent Environments, Genetic Profiling could potentially be used to generate a large number of synthetic evaluation participants, each providing different anthropomorphically realistic interaction performances [7]. To illustrate this further, the research presented in this paper outlines results from an investigation evaluating the anthropomorphism of artificial Genetic Profiling behaviour-sets, designed for NPCs inhabiting an intelligent household environment. During this experiment an amalgamated collection of real behavioural data was gathered from multiple different sources, including a combination of physical, virtual and mixed reality intelligent environments, each depicting a household scenario.

Following this introduction is a brief overview the theory behind this research, including a description of how assigning synthetic representations of human Personalities to NPCs can potentially increase the realism of their behaviour patterns. Following this the Genetic Profiling concept is presented, accompanied by an outline of how the mechanism can be used to generate artificial Personalities suitable for NPCs featured in computer game scenarios. Following a description of the different iWorlds (Information Worlds) used to gather behavioural data from real people, the methodology and results obtained from the Genetic Profiling anthropomorphism evaluation are then presented. Finally, an analysis is provided, detailing the key observations and conclusions made by this project.

1. Background Information

1.1. Generating Artificial Personalities for NPCs

To allow NPCs to exhibit behavioural performances more similar those of real humans, the Genetic Profiling mechanism was designed to generate rudimentary artificial Personalities to be used as decision-makers in controllers. Each Personality contained a number of behaviour-sets appropriate to represent each aspect of an NPC's role within the context of a scenario or environment. Although several different theories, models and approaches exist to describe the actual structure, content and origins of human Personalities, the general consensus from a psychological perspective is that they serve to impose influences upon individuals, constantly affecting their decision-making and actions [12, 13]. Several computer games and other Computer Science research projects have attempted to replicate this functionality, often by creating collections of weights to represent different characteristics or traits present within individual characters. Depending upon the approach taken, such a system could be as simple as assigning different values to a set of attributes common to every NPC in a world. Another possible strategy might be to select a personal subset of characteristics from a larger collection for each individual. In either case, the values of the variables would likely be applied to some mathematical calculation then used to add biases when deciding upon a behavioural response for any encountered stimuli. However, although such implementations may be capable of allowing NPCs to give reasonable performances, the behavioural patterns they demonstrate might not necessarily be representative of typical anthropomorphic behaviour.

Any lack of anthropomorphism in an NPC performance may be partly due to the fact that their Personality isn't the only source of influence potentially acting upon an individual during any given moment. An important factor to consider is that according to Psychology, once developed, the influences exhibited by a Personality on an individual will remain largely constant. For instance, a kind person will always behave in a kindly manner and can be expected to exhibit this characteristic to some extent in all of their chosen actions. Therefore, from Computer Science perspective it may be simpler to consider a Personality as a representation of the default model for a specific individual. However, there are many additional factors, not directly connected with an individual's Personality or mental state, which may also play a significant role in any decision-making process. For example, there could be internal attributes related to the current physical state of an individual, (e.g. are they ill, bored, hungry, tired, etc.). Likewise, influences could also originate from external sources, which could be manmade, (e.g. the content or layout of an environment), or perhaps the result of natural events, (e.g. weather conditions). Furthermore, a significant number of these additional influences may be completely unknown or unidentifiable even by the individuals themselves, possibly emerging from deep within their own sub-conscious, or as undetectable background noise within an environment. Whether directly relevant to a specific scenario or not these influences still act upon individuals in a similar manner to their inbuilt Personalities. These factors all play a combined role in the decision-making process, eventually leading to an action being selected from a range of possible options. There could also be instances where some over-lapping might occur between characteristics contained within a Personality and other unrelated influences. Therefore, such influences should not be ignored by an NPC decision-making system.

1.2. A Mimicked Approach

One potential approach allowing the effects contributed by known or unidentified internal and external influences in a scenario to be taken into account was to use Mimicry. In other words, a logging system simply records actions demonstrated by real people which are subsequently replayed by NPCs. Alternatively, rather than using Mimicry to simply copy the performance of a real person in its entirety, the strategy can also be designed to create behavioural fragments, (i.e. the individual actions). These fragments could potentially be later recombined into more complex behaviours. For example, in 2000, a signal processing research project led by Kenmochi Hideki, developed voice synthesizer software replicating human singing performances [2]. This software used as the base for *Vocaloid* (Yamaha Corporation, 2004), which used pre-recorded phonic samples mimicked from real voice actors to generate artificial sounds, (i.e. singing or other verbal performances) [11].

1.3. An Evolutionary Approach

Another possible means of generating anthropomorphically realistic behaviour-sets would be to use an evolutionary approach to create NPC controllers in a pseudo-natural manner. Evolutionary Algorithms form an area of Computer Science, encompassing numerous Artificial Intelligence mechanisms, each designed to evolve solutions to problems using approaches largely inspired by Darwinian Natural Selection. For example, Genetic Algorithms were used by the Gershwyn project to research artificial creativity in song writing [15]. Learning Classifier Systems were used by Priesterjahn

et al, to generate rules for their reactive virtual boxing NPC controller, [14]. Finally, Karl Sims used Genetic Programming to evolve several virtual creatures inhabiting several environments, simulating land and ocean-based ecosystems [16].

Some of the examples describing Evolutionary Algorithms projects can also be classified into another area of Computer Science research, specifically Artificial Life. For example, John Horton Conway's 'Game of Life' demonstrated two-dimensional Cellular Automata, where users created the initial pattern of a universe then watched as it evolved over time, spawning different representations of synthetic life [9]. The Avida Artificial Life system took a similar approach, using a population of strings containing machine-language-style instructions, known as genomes [1]. The benefits of placing an emphasis on replicating various natural biological processes for NPC controllers have been demonstrated by numerous other Computer Science projects, including implementations used in past commercial computer games. For example in *Creatures* (Millennium Interactive, 1996), Artificial Neural Networks were used to replicate an entire physiological system [10].

1.4. So which approach is best?

When it comes to portraying realistic representations of real human behaviours Mimicry is a cost-effective method that is almost always guaranteed to produce useful results. After all, if avatars are replaying actions previously demonstrated by real people, this grounding alone should be sufficient to ensure an anthropomorphic behavioural performance. However, Mimicry is by no means a perfect system. In addition to difficulties identifying influence sources such as those discussed earlier, adopting a purely Mimicry-based approach when implementing NPC controllers could potentially result in countless perfectly acceptable actions present in scenarios simply being ignored, as they were not performed in any of the recorded behaviour-sets.

Unfortunately the situation doesn't look much better from an evolutionary perspective. For starters, to a large extent both Evolutionary Algorithms and Artificial Life systems require a description of all the possible actions that could potentially be performed and influences present prior to the start of a session. Identifying all these possibilities could be challenging and time-consuming for programmers, especially in complex scenarios and environments. Another issue with an evolutionary-based approach is that unlike Mimicry any possible action that could be performed by an NPC may be chosen at some point. While this does potentially permit new ad hoc behaviour generation, there is no guarantee that the action patterns would resemble decision-making exhibited by real people when in similar circumstances.

2. Genetic Profiling

To achieve the aims of this project, a new Artificial Intelligence mechanism was required, which could allow the anthropomorphic grounding obtained from mimicked data to be combined with the artificial variation produced by Evolutionary Algorithms and Artificial Life systems. Consequently this led to the creation of the Genetic Profiling mechanism, which combines elements of Mimicry with an evolutionary-based approach, initially inspired by techniques used in Genetic Programming. The Genetic Profiling mechanism was designed to be easily customisable to suit a variety of different scenarios. Many traditional Evolutionary Algorithms typically require

advanced knowledge of any possible actions and functions that can be used to create behaviours. However, thanks to a Mimicry-based profiling system Genetic Profiling can dispense with this requirement, with possible options simply being discovered by the system during a session, allowing new behaviours to naturally emerge.

2.1. Implementation Strategies

Two different implementation strategies were devised for the Genetic Profiling mechanism. The following is a brief overview of each method.

2.1.1. Benchmark Genetic Profiling

The first implementation strategy was dubbed ‘Benchmark Genetic Profiling’. At the start of each session the mechanism selected a single Mimicry Profile from the stored collection available to the system, to act as a benchmark. An initial population of randomly generated behaviour-sets were created by the evolutionary component. Each of these samples were subsequently tested for fitness and ranked based upon how similar in structure they were to the content stored in the selected benchmark.

Subsequent generations of samples were created by applying genetic operators (i.e. crossover, mutation and reproduction) to samples selected from the previous population using a Fitness Proportional Selection method. During the fitness evaluation process, Artificial Profiles with a higher or lower number of behaviours than the benchmark Mimicry Profile were penalised. This measure was taken to ensure behaviour-sets similar in size to the mimicked benchmark would be returned by the system.

2.1.2. Direct Genetic Profiling

The second implementation strategy was dubbed ‘Direct Genetic Profiling’. When a session commenced, the initial population of samples were created by randomly selecting Mimicry Profiles from the available collection. It was possible for the same Mimicry Profile to be selected for multiple samples, especially if the collection was smaller than the required population size. This initial population then had the genetic operators from the evolution component of the mechanism, (i.e. crossover, mutation and reproduction) applied directly to the content of their behaviour-sets.

By using the actual mimicked data for an initial collection of Artificial Profiles, the mechanism can directly pass on fragments of anthropomorphic behavioural patterns, as demonstrated by real humans, to samples in subsequent generations. Implementation of the fitness measure in the Direct Method was more bespoke than that of the Benchmark Method, as the anthropomorphic properties of Artificial Profiles required grounding appropriate to the environment or scenario being used. Typically, the fitness was calculated by comparing differences in magnitude of delta values for pairs of adjacent behaviours in the artificial sets. The theory behind this approach was that by assigning better fitness values to Profiles with the smallest differences between adjacent actions, unrealistic behaviours created by combining content from several different sets together could be avoided.

2.2. Artificial Personality Representation

The Genetic Profiling mechanism was designed to create individual behaviour-sets based upon the anthropomorphic action patterns mimicked from real people. However,

when creating artificial Personalities for NPCs, it is possible to combine several Genetic Profiling behaviour-sets to stage even more complex performances. This could potentially allow NPCs to adapt to changes in their current environment. For example, many real people might behave entirely differently in a working environment, compared to how they act back in the privacy of their own home.

Essentially, from the perspective of this project, an artificial Personality can contain a single or multiple behaviour-sets, which in turn each include one or more behaviours (i.e. actions) representing decision-making. Behaviour-sets created from several different scenarios or environments can be represented in a single Personality as different Personae. Each Persona is comprised from one or more behaviour-sets created by performances in the same environment or scenario. Personae containing multiple behaviour-sets can potentially be used to allow NPCs to exhibit behavioural changes occurring during long-term performances, (e.g. different days of a week). This can also potentially prevent them from giving repetitive or predictable performances, which may appear non-anthropomorphic to observers.

3. Evaluating NPC Anthropomorphism

3.1. iWorld Environments

The iWorld concept, discussed in several of this project's earlier papers, [6, 8] was applied to this investigation. Several iWorlds each modelling a similar intelligent household, were implemented specifically to observe and record inhabitant behaviours when interacting with the environment, generating a collection of mimicry data.

3.1.1. A Physical Intelligent Environment

The first iWorld used to gather mimicry data from evaluation participants was provided by the University of Essex iSpace, a purpose-built self-contained intelligent building, designed to resemble a typical household environment [3]. To aid the discreet deployment of a large network of embedded sensors, intelligent devices and other technologies, panels concealing hollow walls and ceilings were incorporated into each room's design. Being an intelligent environment, all the smart-devices featured in the iSpace were linked with a single network, controllable and observable via computer code, using a series of inbuilt OSGI UPnP wrapper methods.

3.1.2. A Mixed Reality Intelligent Environment

Mixed Reality has also been used in a number of Pervasive Computer Science projects, such as those allowing devices or other features in intelligent environments to be remotely observed or controlled via simple GUI graphical interfaces or more complex virtual worlds [4, 6, 8]. To replicate this functionality another iWorld was created by augmenting the existing physical iSpace environment with a new bespoke virtual component. Figure 1 shows views of the physical and virtual components used in this iWorld design. In addition to cloning intelligent devices and augmenting static objects in the physical iSpace, entirely new smart technologies not present in the physical environment were added to the virtual component, increasing the range of actions that could be performed by inhabitants.



Figure 1. The Mixed Reality Intelligent Environment

3.1.3. A Virtual Intelligent Environment

Sessions recording mimicry data from participants using the physical and Mixed Reality iWorlds were performed in real-time and in a surrounding that realistically represented the scenario and intended context. Interaction involved participants manually using devices, demonstrating realistic anthropomorphic behavioural patterns. However, a third option was also available, potentially allowing anthropomorphic behaviours to be observed without the need for real-time experimentation sessions.

Taking inspiration from the Artificial Intelligence systems used by some existing commercial computer games, such as *The Sims* (Maxis / EA Games, 2000), the final iWorld, (shown in Figure 2) assigned four ‘Needs’ variables to each session participant, (i.e. Boredom, Hunger, Hygiene and Tiredness). These variables were intended to represent some rudimentary states common to all real people and were used to create specific stimuli, prompting behavioural responses from participants.

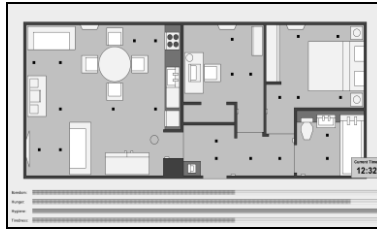

Figure 2. The Virtual Household Game Environment

3.2. Evaluation Strategy

3.2.1. Generating Mimicry Profiles

As this project was mainly interested in generating NPCs for use in computer games, it was desirable to encourage behaviour-sets containing interesting, (i.e. active) performances to be selected by the Genetic Profiling mechanism more frequently. Consequently, approximately ninety percent of the final collection of mimicry profiles used during the evaluation was generated by the Virtual Household Game Environment. The remainder of the mimicry collection was provided by the two other iWorld systems. By using this disproportionate ratio it was possible to significantly influence the general style of many subsequent artificial behaviour-sets generated by the Genetic Profiling mechanism. However, the grounded anthropomorphic behaviour-patterns gathered in the other iWorlds still provided significant contributions when selected by the crossover or mutation genetic operators. To suit other Intelligent Environments or Cloud of Things related projects, the ratio could potentially be adjusted to place greater emphasis on the mimicked data generated in the physical or Mixed Reality iWorlds.

3.2.2. Assessing NPC Anthropomorphism

Unlike the experimentation strategies used in other investigations from this project, a slightly different approach was adopted for this evaluation. Rather than presenting participants with a graphical representation of different NPC performances, this evaluation chose to concentrate on the content of the generated behavioural patterns themselves. During each experiment session, evaluation participants were presented with images of four different behaviour-sets. Three of the sets displayed unmodified Mimicry Profiles, generated in the investigation iWorlds. The single remaining sample was generated using one of the Genetic Profiling implementations. Evaluation participants were simply asked to identify which of the behaviour-sets they believed had been generated by an Artificial Intelligence.

Inspired by the methodology used for the Turing Test analysis [5, 17], the intention of this experiment was to assess whether Genetic Profiling behaviour-sets could successfully fool people into believing they were created by the actions of real individuals. The theory was that even minor inaccuracies in the content or pattern structure of a behaviour-set would attract attention from any observer when compared with similar data-sets obtained from real people. If no noticeable imperfections were present then the artificial behaviour-set could be considered similar to the Mimicry Profiles. Hence any NPC performances should appear to be anthropomorphic in style.

3.3. Evaluation Results

3.3.1. Benchmark Genetic Profiling

The experiment assessing the potential anthropomorphism of behaviour-sets generated by Benchmark Genetic Profiling presented participants with the four Profile designs shown in Figure 3. No time limit was imposed on how long a participant could observe the behaviour-sets, which were all displayed onscreen simultaneously. The experiment informed participants that three of the behaviour-sets were created by recording the actions of real people in a household environment, while the one remaining Profile had been generated by an Artificial Intelligence system. When they were ready participants were simply asked to try and identify which of the four behaviour-sets they believed had been generated by the Artificial Intelligence system. Table 1 presents the choices made by the participants during their respective sessions. For clarity, the correct answer to this question, (i.e. the behaviour-set generated by the Benchmark Genetic Profiling implementation) is highlighted in grey.

The results obtained from the first experiment, shown in Table 1, strongly indicated that the artificial behaviour-set generated by the Benchmark Genetic Profiling implementation was capable of appearing anthropomorphic, when directly compared with real human performances. Attracting approximately one-fifth of the recorded votes, (significantly below the twenty-five percent average threshold), the Artificial Profile appears to have successfully fooled a large majority of the evaluation participants. Indeed the Genetic Profiling behaviour-set actually scored fewer votes than two of the three Mimicry Profiles used in the experiment.

1	09:46	Computer
2	10:32	Oven
3	12:59	Kitchen Sink
4	14:54	Sofa 2
5	16:20	Television 1
6	18:13	Oven
7	19:42	Bath
8	21:50	Bed

1	10:41	Chair 3
2	12:15	Stereo
3	13:53	Refrigerator
4	16:32	Bath
5	19:02	Sofa 2
6	20:04	Television 1
7	21:08	Oven
8	22:31	Bed

1	09:58	Chair 5
2	10:38	Computer
3	12:17	Refrigerator
4	13:35	Toilet
5	14:33	Sofa 2
6	16:44	Television 1
7	17:47	Oven
8	18:50	Kitchen Sink
9	21:03	Chair 2
10	22:14	Television 1
11	23:31	Bed

1	09:13	Sofa 1
2	10:12	Television 1
3	11:10	Refrigerator
4	11:35	Kitchen Sink
5	12:52	Sofa 2
6	13:39	Stereo
7	14:09	Oven
8	15:22	Bath
9	16:06	Chair 5
10	16:32	Computer
11	18:03	Oven
12	18:48	Bathroom Sink
13	19:07	Bath
14	19:35	Bed

Figure 3. Mimicry & Benchmark Genetic Profiling Behaviour-Sets

Table 1. Benchmark Genetic Profiling Evaluation Results

Instance	Number Selected	Percentage Selected
Top-Left Table	12	18.8%
Top-Right Table	29	45.3%
Bottom-Left Table	16	25%
Bottom-Right Table	7	10.9%

3.3.2. Direct Genetic Profiling

The same strategy used in the first experiment was applied when evaluating the potential anthropomorphism of performances exhibited from behaviour-sets generated by the Direct Genetic Profiling implementation. Figure 4 shows the four behaviour-set designs presented to the evaluation participants. As in the first experiment, three of the behaviour-sets were unmodified Mimicry Profiles. The one remaining behaviour-set was generated using the Direct Genetic Profiling implementation. The distribution of votes obtained from the participants of this experiment is shown in Table 2. As before, for clarity the correct answer to this question was the table option highlighted in grey.

In this instance the Direct Genetic Profiling implementation attracted slightly more correct identifications from participants than the associated Mimicry Profiles. However, as shown by the results, approximately 70% of the evaluation participants were successfully fooled by the presented Artificial Profile, suggesting many would consider a NPC demonstrating that behaviour-set to be giving a realistically anthropomorphic performance. Furthermore, there was an even split of the scores obtained by the three Mimicry Profiles and all four sets of votes were close to the twenty-five percent average. Based upon probability, this pattern could potentially suggest that many of the participants may have simply been randomly guessing when making their selections during this experiment. Therefore, the ability of Direct Genetic Profiling to generate anthropomorphic behaviour-sets similar to those generated by real people may actually be even better than indicated by the results in Table 2.

1	10:41	Stereo
2	12:59	Oven
3	14:50	Kitchen Sink
4	15:51	Sofa 2
5	17:59	Bath
6	19:49	Sofa 2
7	20:16	Television 1
8	21:30	Oven
9	23:17	Bed

1	09:34	Sofa 2
2	11:01	Television 1
3	13:05	Oven
4	14:30	Toilet
5	16:48	Sofa 2
6	18:22	Refrigerator
7	20:07	Television 1
8	21:09	Bath
9	22:42	Bed

1	09:46	Computer
2	10:31	Oven
3	12:59	Kitchen Sink
4	14:55	Sofa 2
5	16:19	Television 1
6	18:12	Oven
7	19:43	Bath
8	21:49	Bed

1	09:58	Chair 5
2	10:38	Computer
3	13:53	Refrigerator
4	16:32	Bath
5	19:02	Sofa 2
6	20:04	Television 1
7	21:08	Oven
8	21:49	Bed

Figure 4. Mimicry & Direct Genetic Profiling Behaviour-Sets

Table 2. Direct Genetic Profiling Evaluation Results

Instance	Number Selected	Percentage Selected
Top-Left Table	15	23.4%
Top-Right Table	15	23.4%
Bottom-Left Table	15	23.4%
Bottom-Right Table	19	29.7%

3.4. Experimentation Strategy Discussion

In its past evaluations this project has typically used an iWorld as a demonstration platform to present actual NPCs, (typically represented using avatars), giving real-time performances to participants. However, this investigation chose to take a slightly different approach. One of the reasons behind this new evaluation strategy was a necessity due to the resources available to this project. From a household environment context, many of the actions performed by inhabitants involved sitting around in one location for potentially long intervals. If they were to appear anthropomorphic, this was still a necessary element of an NPC's performance even after adopting a more computer game, (i.e. active) behavioural style. However, it simply wasn't possible for this project to implement a bespoke demonstration iWorld capable of effectively portraying behaviours, such as eating, which would have required NPCs to manipulate minor objects over sustained periods. It was felt likely that any produced presentation could potentially induce confusion from any uninformed audience during an evaluation, which may have distorted the obtained results. While this limitation wasn't a problem when gathering data for Mimicry Profiles, (as avatars weren't used in the iWorlds for this investigation), the concern was that evaluation participants may confuse the graphical restrictions of exhibited actions performed by NPC avatars as evidence of non-anthropomorphic behaviour. By removing the graphical component from the actual experiments, it was hoped that the context of the investigation could be kept in focus amongst participants, preventing the distortion of obtained results. Effectively, this experiment asked people use their own imaginations to visualise the performances given by NPC avatars following each of the presented sets of behaviours.

4. CONCLUSIONS

4.1. *Summary & Research Findings*

This paper has presented an introduction to a new Artificial Intelligence mechanism ‘Genetic Profiling’, designed primarily to encourage realistic anthropomorphic behaviours, (i.e. decision-making and actions) to be performed by NPCs (computer-controlled representations of humans) in computer games and other contexts. The investigation reviewed in this paper demonstrates how mimicked data obtained from a large number of people, using several different source environments, could be combined to allow the generation of useful artificial behaviour-sets, focused towards an intended purpose. In this example that purpose was for use in the controllers of computer game NPCs, but the same methodology could also be applied to generate behaviour-sets suitable for other Computer Science research areas. Indeed, two of the three iWorlds used to supply mimicry data during this investigation made use of a full-scale physical Intelligent Environment, which could have also been used to playback artificial Genetic Profiling behaviour-sets stored in generated NPC controllers.

A description of the internal architecture of the Genetic Profiling mechanism has been provided, describing how naturally anthropomorphic behaviours can be mimicked from real people and subsequently applied to an evolutionary process to create multiple new artificial behaviour-sets. Also highlighted was a new model describing how one or more of the artificial behaviour-sets generated by Genetic Profiling could potentially be structured to create replica human Personalities, designed for NPC controllers.

Finally, the evaluation procedure used by this investigation to assess the potential levels of anthropomorphism obtainable from artificial behaviour-sets generated by Genetic Profiling implementations was presented. The iWorlds used to gather the initial mimicry behaviour-sets for the system were outlined, each based upon a typical Intelligent Environment architecture. Also described was the new evaluation strategy, partially inspired by the Turing Test, which was used to assess whether artificial Genetic Profiling behaviour-sets could fool people into believing they were representing the behavioural patterns of real individuals.

Two separate experiments were performed to evaluate each of the potential Genetic Profiling implementation strategies. Overall, the results obtained from the sessions performed in each experiment provided some encouraging results from the perspective of this project’s research focus. Both the Benchmark and Direct Genetic Profiling implementation strategies demonstrated that behaviour-sets generated by either method were able to successfully fool a significant majority of evaluation participants into believing they represented actions performed by real people. By successfully concealing the Artificial Profiles amongst a collection of behaviour-sets created by mimicking the behaviours of real people, there is a strong indication of anthropomorphism in the generated content. Therefore, NPCs using one or more of the generated behaviour-sets in artificial Personalities should be exhibiting a strong level of anthropomorphism from their decision-making and any subsequent actions performed.

4.2. *The Next Step*

The next phase of this project will see the Genetic Profiling mechanism being applied to NPCs performing different roles in various computer game-based environments. Internet-based computer games, attracting millions of players, who access common

virtual worlds to play remotely, will be explored further. Massive Multiuser Online worlds like these may potentially offer an abundance of anthropomorphic mimicry data.

Another area to be explored is how Genetic Profiling can be applied to suit the different uses of NPCs in computer games. Many are used to provide competitive opponents to challenge, while others might fight alongside the real players as support characters. Some games use NPCs simply as background characters to increase the immersion presented by a virtual environment, while others can use them simply to provide information crucial for advancing an ongoing plotline. This project hopes to investigate whether the Genetic Profiling mechanism can be applied to each of the identified NPC types in a variety of different scenarios, in each case attempting to increase the anthropomorphism in their performances, to make their behaviour appear more similar to that of real human players. Evaluations comparing each version of Genetic Profiling with other potential NPC Artificial Intelligence mechanisms will also be staged during this phase.

References

- [1] Adami C., Brown C. T., "Evolutionary Learning in the 2D Artificial Life System "Avida"", *Proceedings of Artificial Life IV*, MIT Press, 1994.
- [2] Bonada J., Loscos A., Cano P., Serra X., Kenmochi H., "Spectral Approach to the Modelling of the Singing Voice", *Proceedings of the 111th AES Convention*, Audio Engineering Society, USA, 2001.
- [3] Callaghan V., Clark G., Colley M., Hagraas H., Chin J., Doctor F., "Intelligent inhabited environments," *BT Technology Journal*, Vol. **22**, No. 3, Klywer Academic Publishers, Dordrecht, Netherlands, 2004.
- [4] Cook D. J., Youngblood M., Heierman E., Gopalratnam K., Rao S., Litvin A., and Khawaja F., "MavHome: an agent-based smart home", *Proceedings of the IEEE International Conference on Pervasive Computing & Communications*, pages 521 – 524, 2003.
- [5] Copeland B. J. (editor), "*The Essential Turing: The ideas that gave birth to the computer age*," Oxford University Press, UK, ISBN 0-19-825080-0, 2004.
- [6] Davies M., Callaghan V., "iWorlds: Building Mixed Reality Environments using Customisable 3D Virtual Worlds", *Proceedings of the 6th IEEE International Conference on Intelligent Environments (IE '10)*, Kula Lumpur, Malaysia, July 2010.
- [7] Davies M., Callaghan V., "Towards Producing Artificial Humans for Intelligent Environments Research", *Proceedings of the 7th IEEE International Conference on Intelligent Environments (IE '11)*, Nottingham, UK, July 2011.
- [8] Davies M., Callaghan V., "iWorlds: Generating Artificial Control Systems for Simulated Humans using Virtual Worlds and Intelligent Environments", *Journal of Ambient Intelligence and Smart Environments (JAISE)*, Vol. **4**, No. 1, Eds. Augusto J. C., Aghajan H., IOS Press, 2012.
- [9] Gardner M., "Mathematical Games: The Fantastic Combinations of John Conway's New Solitaire Game "Life" ", *Scientific American*, Vol. **223**, pages 120 – 123, October 1970.
- [10] Grand S., "*Creation: Life and How to Make it*", Phoenix, ISBN 0-75381-277-0, 2000.
- [11] Kenmochi H., Ohshita H., "Vocaloid: commercial singing synthesizer based on sample concatenation", *Proceedings of Interspeech 2007*, Antwerp, Belgium, 2007.
- [12] Kline P., "*Personality: The Psychometric View*", Routledge, London, UK, ISBN 0-415-08977-8, 1993.
- [13] Pennington D. C., "*Essential Personality*", Arnold, Hodder Headline Group, London, UK, ISBN 0-340-76118-0, 2003.
- [14] Priesterjahn S., Kramer O., Weimer A., Goebels A., "Evolution of Human-Cooperative Agents in Modern Computer Games", *Proceedings of the IEEE Congress on Evolutionary Computation (CEC '06)*, pages 777-784, 2006.
- [15] Rubenstein R., "Gershwyn mixes up a right racket", *ElectronicsWeekly.com*, <http://www.electronicsweekly.com/Articles/1998/07/01/7906/gershwyn-mixes-up-a-right-racket.htm>, Retrieved: November 2008.
- [16] Sims K., "Evolving Virtual Creatures", *Proceedings of the ACM Special Interest Group in Computer Graphics (SIGGRAPH '94)*, pages 43 – 50, July 1994.
- [17] Turing A. M., "Computing Machinery and Intelligence", *Mind*, Vol. **59** pages 433 – 460, 1950.

The Maker Fables

Vic CALLAGHAN

Department of Computer Science, University of Essex, UK.

Abstract. This Science Fiction Prototype explores the idea that the current interest in maker space activities could continue to grow to the point that it causes a sea change in the manufacturing industry as it shifts from centralised production in factories, to a distributed production in people's communities or homes. This move is a natural extension of a number of research trends, such as the increasing ability to personalise products and the popular trend of making or adapting things. We contextualise this within current concepts such as virtual appliances and buzzboards and micro industries before presenting a series of vignettes that take a potpourri look at some related ideas. Finally, we conclude the article by reflecting where this technology could go in the future.

Keywords. Maker-space, hacker-space, virtual-appliances, science-fiction, product innovation

Introduction

One of the current trends in technology is personalisation [1]. Personalisation is evident in many areas of people's lives such as their choice of clothes and home decoration through to more technical environments such as personalizing screen layouts on computers. It seems that this propensity for personalisation is closely related to people having a fascination with making things, as is evident by the vibrant hobbyist scene and, to some degree, the related cottage industries. The 'arts and crafts' industries are one such example that unleash people's creative talents and fulfil their desire for personalisation. While there are all kinds of such activities, in this article we are especially concerned with technology, particularly computing and electronics. In this area there are a number of popular movements, most notably maker or hacker spaces. According to Wikipedia, maker or hacker spaces are "*a community-operated workspace where people with common interests, often in computers, technology, science, digital art or electronic art, can meet, socialise and/or collaborate*" (<http://en.wikipedia.org/wiki/Hackerspace>). Their roots can be traced back to the early nineties, although it is only in the last 5 years that their popularity has soared. These spaces often go by a variety of other terms such as 'hacklab', or 'hackspace'. Many people claim the terms hacker and maker are interchangeable, although purists would argue that 'maker spaces' have a broader remit that extends into non-technical areas, such as 'arts and crafts'. For the purposes of this article, I will use these terms interchangeably. The fact that the activities are group based is an important distinguishing feature to the isolated home hobbyist, as the people that participate in maker spaces are often professionals, sometimes with aspirations of inventing products and establishing new businesses. As these are largely ad-hoc groupings, drawn together by a shared interest in building personalized goods, it's hard to generalize on their

motivations, apart from noting that a common denominator across these areas is personalization, albeit often in a more physical sense. The kind of tools that are used in these spaces are highly modularized embedded computer systems. An excellent example of these are Buzz-Boards (www.FortiTo.com), in which developer can plug together boards with differing electronic functionalities to produce products with an overall; functionality they desire [2] [3]. A useful feature of Buzz-Boards is that they allow different physical configurations thereby enabling the constructed system to take on a shape that is closer to the envisaged final product. Thus for example they can be used to make products that range from small wearable medical systems, through desktop robots, to large living spaces such as smart-homes. Maker-spaces can be regarded as a type of informal learning environment, as the group support is often focused on instructive advice, resulting in learning, especially by less knowledgeable members. Indeed, there is a wider commonality between hobbyists, maker-spaces, education facilities and company R&D laboratories as they are all trying to rapidly create working prototypes. Interestingly, the class of technology they use is more frequently referred to as rapid prototyping systems. The Buzz-Boards are good examples of this but there are more, such as Arduino [www.arduino.cc/], Raspberry Pi [www.raspberrypi.org/] and mbed [<http://mbed.org/>].

The movement from centralized to local production is a fascinating development that is well described in an interesting article written by Chris Anderson for *Wired* in which he describes what he refers to as a coming “*age of open source, custom-fabricated, DIY product design*” [4]. In particular he explores the potential for what he terms new ‘micro-factories’ with the current tools of the trade being products like electronics modules through to 3D printers. In that respect he notes that hardware is becoming much more like software in terms of its malleable design features. It’s a powerful vision of a distributed industry made up of thousands of micro-producers varying in size from individuals to small groups of people with a shared need. He points out that, with computer networks connecting such micro-factories (or even current factories), there is the potential to set up a meta-layer of virtual-micro factories able to design and sell goods without any infrastructure. In other words, such supply chains become scale-free, meaning they can serve small and large customers with equal ease. One very interesting issue he explores is “Why do companies exist”? He quotes Bill Joy of Sun Microsystems as saying “*No matter who you are, most of the smartest people work for someone else*”. Given the changing capabilities and economics of production, that question seems worth revisiting especially as everyone’s shed or garage has the potential to be a high-tech factory. Interestingly, Anderson reports that most such micro-factory units produce thousands of devices with a shipment of 10,000 being considered a breakout success. One inspiring example he cites is Aliph, who make the Jawbone Bluetooth noise cancelling microphone and headset which they ship by the million, without any factory facility (outsourcing all their production), an achievement that demonstrates the potential for this approach. Another interesting example he cites is a new breed of ‘open source car company’, ‘Local Motors’, whose first car the ‘Rally Fighter’ is based on a crowd sourced design and is manufactured with the help of a kit car company in numerous locations, close to where the potential owners live.

Concerning computers their programmable nature of make them especially well-suited to personalization and micro-production. The challenge for computers is that, although

programming makes them ideal candidates for maker-spaces and micro-industries, it also demands highly technical skills, such as those offered by university level degree courses. Fortunately there is an area of study that is seeking to make computers easier to programme; end-user programming. One notable approach was devised by Chin, Pervasive-interactive-Programming, which provides an ingenious natural way for people to program pervasive computing systems whereby, they simply demonstrate (via physical action), the behaviour they want from the system [1]. Moreover, Chin also proposed a novel idea for creating a new generation of ‘maker’ compatible appliances (ie appliances that can be built or adapted by ordinary people) that she labelled “virtual appliances” [5]. Virtual appliances are created by aggregating network service (including physical services such as lighting, media etc) to create a virtual product that acts directly in the real physical world. The principle is based on disaggregation of traditional appliances into basic services and then offering them for re-aggregation to network users. The re-aggregation process can create regular appliances such as TVs or home security or, by using more creative mixes, can lead to novel appliances “invented” by the user. In that sense, when combined with end-user programming tools, this is the ultimate of the current maker space approaches. Perhaps the ultimate example of this type of localised making capability is the Star Trek replicator, which is a machine capable of creating objects (including food) from more basic atomic material but, of course it’s just fiction. Whether such a vision will ever come about is uncertain, but in the following fictional tales, it’s fun to mull over some of the possibilities.

1. Science Fiction Prototyping

In this article we will explore a number of possible futures based on the use of a type of scenario called a science fiction prototyping (SFP) [6]. The differences between SFPs and more common scenario based design that are used in other areas are that they are set in a more distant future time (usually, at least 20 years out and often much longer). The idea is not necessarily to produce a prototype directly from the story (although that is always nice!) but rather to inspire a type of thinking that may lead to innovative concepts and products at some later time. Another important role of an SFP is to set the technology discussion in a holistic and credible social environment, using the story to explore the potential and consequences of the technology (www.creative-science.org). For the interested reader, there are numerous other examples of SFPs [7] [8] [9] [10]. In our case we have set our stories in periods that range from as little as 5, to as much as 50 years in the future. We are employing a diverse mix of characters, each with their own situations and peculiarities, as is the way of the human condition.

In the following section I present four very short SFPs that provide different views of what maker spaces are, or what they might do.

2. The Vignettes

The future is impossible to predict and the range of possibilities is enormous, so the following are just small potpourri of tales that are intended to stimulate a wider discussion rather than motivate any particular thread of research. The first, “*Daisy’s Present*”, explores a near term view of maker spaces; one that embraces school kids

and multidisciplinary possibilities. The second *“The Dream”* is timeless, and just poses the question as to whether universities’ are maker spaces, or could be. The third, *“Immortality”* is more futuristic and centres around a near-singularly period, examining the notion of maker spaces applied to people making reproductions of themselves. Finally the forth story asks if maker spaces are intrinsic to our existence.

2.1. *Daisy’s Present*

“Fatty, fatty, you’re a massive fatty fatty, fatty, you’re a massive fatty”, Daisy sobbed quietly, as her friend, Dale gently rested his arm around her shoulder. *“It’s not fair is it, what have I got to do, you know my mum tries so hard to give me the right food but still this happens”* (she sobs a little more). *“What more can I do, she murmured”*. Dale felt heartbroken to see Daisy in such pain, they had been friends since they were crawling babies, and she was always beautiful in his eyes. *“Daisy, this may sound a little crazy but I may have an idea of how we might be able to help ourselves, and maybe lots of other kids”*. Daisy’s face brightened up a little as she looked up at her friend; she knew she could always rely of him to reach out his helping hand whenever she was in trouble, so even though she didn’t think there was any other answer other than people having more empathy and love, she was touched that Dale wanted to help make her world better. *“What would I do without Dale in my world, it would be a horrible place without him”*, she thought. *“You know on Tuesday and Thursday nights I have been staying behind at school at the ‘Makers Club’”*, *“that’s because you are a geek”*, cut in Daisy, with a slight smile returning to her face, *“don’t tell me the school makers club can do something to help me, what have geeks ever done to help girls apart from turning them off, her face now almost laughing”*! *“Whatever your idea, you have already made me feel better”* she said, now audibly chuckling *“a geek’s club helping me!”*. *“Well”*, said Dale, with his arm still around his friends shoulder, *“you see in this club we are learning how to invent our own products, there is this system called Buzz-Boards that operates with a cloud based supporting infrastructure and all you have to do is to plug them together in different ways to create really cool things; we have been making robots but there is a whole set of body sensors that measure things like physical activity and even what’s happening inside your body; I thought I could make something for you, to help you, maybe to monitor how much exercise you have every day and how healthy your body is?”*. He looked at daisy, the smile had gone from her face, he was worried he had upset her, maybe, he wondered *“talking about attaching technology to her made her feel even more of a freak than she already felt, maybe she was horrified and thinking he was proposing to turn her into some kind of Frankenstein”*; the silence and emotionless expression remained on Daisy’s face drilling a painful hole into his heart, until she threw her arms around him, gave him a massive hug and said *“that is brilliant, and you know what, I’m going to ask the domestic science teacher if we can start a makers club for cooking; ok, I know it’s not technology, but it is about lifestyle and you can’t argue that cooking is not about making things; the difference will be we will making healthy food, which together with your maker club technology we will be able to produce something really useful for kids, thank you so much for that truly wonderful present; it’s going to take us on a great adventure, who knows where we will go, but I already feel so much better so much better maker spaces are cool!”* .

2.2. *The Dream*

Bang was wandering along Binjiang Avenue, next to the Huangpu River in Shanghai, feeling a little lonely, mostly because his girlfriend, Bik, was spending 12 months as a visiting professor at Essex University. However, as much as he missed her, he was grateful for modern technology that kept them in contact, especially instant messaging (IM) as it provided a type of always-on connection without being too intrusive, which was important as he shared his office in Shanghai Jiao Tong University with other people. Bik was 8 hours behind Shanghai time, so it was almost 4pm before he saw her appear on IM.'

Bang: *Hi Bik, nice to see you online, how did yesterday go?*

Bik: *..... and really nice to be talking to you, I'm missing you :-)*

Went to an interesting meeting in Colchester about 'Maker Spaces

It's a neat idea, a community of people helping each other build things

Bang: *You mean like the communes we had under communism?*

Bik: *Haa haa, maybe a bit like that*

Bang: *what kind of things do they build?*

Bik: *mostly technology, they have a neat plug & play system, see www.FortiTo.com*

Bang: *what is the goal of it; why do people go?*

Bik: *seems they have lots of different reasons, such as:*

some for education (learning new skills, maybe for new jobs)

some to build a new product they think they have invented (budding entrepreneurs)

some to network (connections for jobs, sales, friendship etc)

some with a community project in mind

Bang: *It's curious the West is reinventing our communes but, actually it sounds useful!*

Bik: *yes, and after I was talking to one of my English colleagues about it.*

He said it reminded him of the way universities once worked

A place for mutual help (including between academics in different universities)

A place that promoted open standards and sharing (crowd sourced IP)

An educational environment that helped people achieve their aspirations)

Bang: *So, are you saying that Universities are a kind of maker space?*

Bik: *Haa haa, as always you are reading my thoughts!*

Well, maybe what I am really saying is

that they are the perfect place to start a new type of Maker Space, one that -

embraces the wide ranging expertise & skills in universities (from science to business)

embraces the international reach of university (easy to do an international start up)

harnesses academic motivation to support innovation (maybe even finance it)

Bang: *Wow Bik, I am impressed, that is a big vision and a beautiful dream!*

Bik: *I'd like to make it more than a dream; make it a reality*

Bang: *I suppose it would have to be a virtual community; online in the cloud*

Bik: *Yes, now breath deep; I made the first web page for it; www.facultycooperative.com*

I hope you can help make this dream come true :-)

.....

.....

...

2.3. *Immortality*

Jax sat in the offices of his company, QSH (Qin-Shi-Huang), or as it was publically known, 'Immortal-Me'; they had just signed up their billionth customer; an amazing achievement which was why he was so thoughtful today. He remembered how he founded the company with the simple idea of providing an eternal memorial for the

deceased by, during their life, letting them sign up for a web page that was guaranteed to be maintained as a record of the person concerned forever (well, as much as anyone could guarantee forever!). That was how his company operated in the early millennium, with simple web page based records but all that changed when he came across a book that described the technological singularity. The book was mostly a dystopian account of the ills that would arise from machines becoming too intelligent. He had to smile when he thought of that moment in 2060, as it changed his life forever. While all those worries about dystopian futures never materialised, the chase for super-intelligence yielded some very useful spin-off technologies (much as the space programme did in the 20th century). Top of that list was ‘whole brain emulation’; the early 21st century was littered with attempts at this, as computers got ever more powerful, with ever more storage space. To the huge disappointment of the scientists concerned, none of their efforts had led to the sort of independent consciousness that we associate with our own lives, rather they achieved somewhat eerie effects that were more reminiscent of the earlier ‘brain in a vat’ thought experiments, which have fascinated both philosophers and science fiction writers alike. However, while these emulations did not function like fully living people, Jax was fast to realise the technology would be good enough for his company needs (creating crude facsimiles of people) and was quick to advertise “whole brain simulations” as a service for his ‘Immortal Me’ venture, which was operated as a type of Maker-Space in which Immortal-Me provided the tools for people to build online versions of themselves; perhaps, mused Jax, the ultimate manifestation of Philip K Dick’s famous novel ‘*We Can Build You*’. Of course people could be quite kind to themselves and create somewhat improved versions, maybe kinder and more generous than in real life. These whole brain emulation had full access to the Internet (being hosted in cloud based engines) and could, for example send birthday wishes to friends (either alive, or perhaps sadly ‘whole brain emulations’ themselves – which, of course, was a little bizarre!). It was even possible to invent new people, that had no prior existence, creating the children you never had or the partner you never had, perhaps exemplifying the maxim “*there is nought so queer as folk*”. Jax chuckled to himself when he thought about these bizarre uses of his technology as he recalled the irony that the failure of whole brain simulation to capture those often bizarre or idiosyncratic qualities of real people in a convincing fashion (and hence the failure of attaining the singularity) was, oddly, the key to the success of his company. Finally, he reflected on his original inspiration that had led to the company’s name, QSH (Qin-Shi-Huang) which was motivated by an account he read about the first emperor of a unified China, Qin Shi Huang (or Shi Huangdi), who ruled China from 246 B.C. to 210 B.C. During his 35-year reign, he transformed the geography and politics of China to an extent that led to him being immortalised in history and through the world renowned terracotta army of at least 8,000 clay soldiers placed in his tomb. However, ironically, he had not seen this would be his best route to immortality as, his main goal towards the end of his life, became finding the elixir of life, which would allow him to live forever! Of course he never found it but his, his story was the inspiration for Jax’s company, so as he rose from his chair to face the new day, he couldn’t avoid wondering how would he, or even world he, be remembered 2000 years on!

2.4. *Genesis*

The speaker began”*there was a Maker-Space where the group took on the challenge to create the most advanced intelligent machine possible. They were inspired*

by the ideas of the singularity and far from being afraid of it wanted to embrace it and build machines that would surpass their own intelligence. Ideally, they wanted to include all the characteristics that make up the human condition (eg free-will, spirituality). There were lots of ideas about how they might do this, one being that they would design machines to design even better machines that would in turn design even better machines and so on, ad-infinitum. So the members of this particular Maker-space decided that they would embark on an experiment to do this, where sets of machines would try to construct slightly better versions of themselves by including some structured (incremental) and random (disruptive) changes to their designs and, assessing good designs by means of a competition in which only the best survived". A voice from the darkened lecture room rang out "so where is this maker space group, I would like to join them?" "you already have", came the reply"

3. Summary and reflections

In this article I have described the current interest in maker-space activities. In doing this I set out the current context which is driven by various technologies such as virtual appliances, 3D printers, modularised embedded-computing kits and the cloud-of-things. I also touched on wider visions of manufacturing that envisage a move away from centralised to localised production, which is typified by the vision for micro-industries. The future is impossible to guess and the possibilities are too large to do justice to any attempt to discuss them in a meaningful way so I simply presented a small potpourri of tales that were intended to engender a wider discussion rather than motivate any particular thread of work. Most of these SFPs assume the existence of a well performing Cloud-of-Things infrastructure. The first story, "Daisy's Present", is a near-time SFP that presented the more classic idea of a maker space being a physical club where people attend but in this case, based in a school and developing multidisciplinary tentacles. It both illustrates classical approaches to system building (the modularised Buzz-Boards) and the potential for a more interdisciplinary approach than some hacker spaces adopt. It also raises the idea that maker space ideas might be a highly motivational concept for schools to adopt. The second story "*The Dream*" is a timeless SFP that sets out to introduce a broader perspective to maker-spaces by raising the possibility that the entire academic system might be considered as being a maker space, and that by overlaying a maker-space layer, it might be possible to create the perfect engine to drive forward innovation and entrepreneurship. The third story "*Immortality*", a futuristic SFP set in a near-singularity period examines an application involving maker-spaces being used by people to make virtual facsimiles of themselves. Apart from the more obvious implications for the changes technology may bring to society, it reminds us that neither our lives nor technology will last forever. The final story, "*Genesis*" revisits the age old question about the nature of our existence posing the question are 'maker activities' intrinsic to our existence and can our world be regarded as a gigantic maker space!

References

- [1] J. Chin, V. Callaghan, G. Clarke, "*End-user Customisation of Intelligent Environments*". In the handbook of Ambient Intelligence and Smart Environments, Editors: H. Nakashima, J. Augusto, H. Aghajan, Springer, 2010, Spring, pp 371-407, ISBN 978-0-387-93807-3.

- [2] V Callaghan, Malcolm Lear, Anasol Peña-Rios, Victor Zamudio, Ping Zhen, “*Putting the Buzz Back into Computer Science Education*”, Future Intelligent Educational Environments 2013 (FIEE’13), Athens, Greece, 16-17 July 2013
- [3] V Callaghan, “*Buzz-Boarding; Practical Support For Teaching Computing, Based On The Internet-Of-Things*”, 1st Annual Conference on the Aiming for Excellence in STEM Learning and Teaching, Imperial College, London & The Royal Geographical Society, 12-13 April 2012
- [4] C Anderson “*Atoms are the new bits; welcome to the next industrial revolution*”, Wired (USA), February issue, pp. 59-67, 2010.
- [5] J. Chin, V. Callaghan, G. Clarke, “*Soft-appliances: A vision for user created networked appliances in digital homes*”. In *Journal of Ambient Intelligence and Smart Environments*, IOS Press, Netherlands, 2009
- [6] B Johnson “*Science Fiction Prototyping: Designing the Future with Science Fiction*”, Morgan & Claypool Publishers, ISBN 1608456552, 2011
- [7] V. Callaghan, “*Tales From a Pod*”, Creative Science 2010 (CS’10), Kuala Lumpur, Malaysia, 19th of July 2010.
- [8] Hsuan-Yi Wu “*Imagination Workshops: An empirical exploration of SFP for technology based business innovation*”, *Futures*, Vol 50, June 2013, ISSN 0016-3287
- [9] Hsuan-Yi WU, Vic Callaghan “*The Spiritual Machine*”, Creative Science 2011, Nottingham, 26th July 2011
- [10] G Graham, V Callaghan, A Greenhill, *Futures*, Special edition on “*Exploring Future Business Visions Using Creative Fictional Prototypes*”, Vol 50, June 2013, ISSN 0016-3287

This page intentionally left blank

3rd International Workshop on Smart Offices and Other Workplaces (SOOW'13)

Peter Mikulecký (University of Hradec Kralove, Czech Republic)

Pavel Čech (University of Hradec Kralove, Czech Republic)

Carlos Ramos (Polytechnic of Porto, Portugal)

This page intentionally left blank

Foreword to the Proceedings of the 3rd International Workshop on Smart Offices and Other Workplaces (SOOW'13)

This section of the Workshops Proceedings presents contributions from the *3rd International Workshop on Smart Offices and Other Workplaces (SOOW'13)*.

The workshop series on Smart Offices and Other Workplaces (SOOW) was launched in 2009 as an event co-located with the International Conference on Intelligent Environments (IE). The second workshop of the series was organized in 2011 also as an event co-located with the International Conference on Intelligent Environments, IE'11, Nottingham.

Besides a number of well-known applications of the ambient intelligence concept in various areas, like smart home environment, or smart support to elderly or handicapped people, we may consider it also as being very suitable for intelligent workplaces development.

An intelligent workplace can be, among its other features, also helpful in managing knowledge which can be usefully needed by the users working in the workplace. Such knowledge can be used not only for solving various problems requiring some expert knowledge to be properly solved, but also for learning at the workplace when creating decisions or looking for solutions of difficult tasks.

The area of smart offices and other similar workplaces goes naturally also behind pure technical solutions, therefore, the workshop aimed also at covering much broader, but related topics, such as organizational and personal motivations for managers in using smart workplaces; specific types and models of smart workplaces for various applications; ubiquity and distributed nature of smart workplaces; or user modeling in smart workplaces, to mention just a few of the topics. In the present edition, the workshop focused on multi-agent solutions for supporting decision-making and support, possibilities of AmI solutions for outdoor workplaces, activities recognition in smart office environment, viewing on intelligent home environment as a potential workplace environment, simulation and modeling of intelligent environments, as well as some other related topics.

The workshop organizers wish to express their gratitude to the PC members and deeply thank the attendees for their participation and interesting discussions.

Peter Mikulecky, Pavel Cech, and Carlos Ramos
Co-chairs of SOOW'13

Creating and optimizing client-server applications on mobile devices

Ricardo ANACLETO^a, Nuno LUZ^a, Ana ALMEIDA^{a,1}, Lino FIGUEIREDO^a and Paulo NOVAIS^b

^a*GECAD - Knowledge Engineering and Decision Support Group
Instituto Superior de Engenharia do Porto
R. Dr. António Bernardino de Almeida, 431
4200-072 Porto, Portugal*

^b*CCTC - Computer Science and Technology Center
Universidade do Minho - Campus of Gualtar, Braga, Portugal*

Abstract. Mobile devices are embedded systems with very limited capacities that need to be considered when developing a client-server application, mainly due to technical, ergonomic and economic implications to the mobile user. With the increasing popularity of mobile computing, many developers have faced problems due to low performance of devices. In this paper, we discuss how to optimize and create client-server applications for in wireless/mobile environments, presenting techniques to improve overall performance.

Keywords. Mobile applications, distributed environments, communications

Introduction

In the age of technology and information sharing, recent advances in wireless data networking and portable information appliances have engendered a new paradigm of computing, called mobile computing, in which users carrying portable devices have access to data and information services regardless of their physical location or movement behavior. Nowadays, it is essential to have solutions that can support mobility and that leverage business data and processes providing access anytime, anywhere. Today's busy mobile workers spend more time on the road than at their desks. With business applications inside and workers outside, mobility is imperative. In this sense, extending a business applications to the mobile worker using any mobile device is imperative. Furthermore, employee productivity decreases when vital data and business processes are not easily accessible. For optimal performance on the job, today's mobile workforce needs business-driven data and tools at their fingertips.

Besides these business applications, there are many other applications that use location and context aware features (e.g., for leisure, community games). Taking as example a leisure application, we talk about a tourism planning support system [1], that takes

¹Corresponding Author

many advantages from mobile devices, like their small size and simplicity. They are easy to carry around and use in all kinds of environments.

When we go on holidays, and because cities are large information spaces, we need numerous guide books and maps that provide large amounts and complicated information in order to navigate these spaces. With a mobile phone we can access all the important information we want about a place. Still, communications with the server-side application are often required.

Mobile devices have the capability of connecting to the Internet through a mobile network. These connections, however, can be significantly slower compared to fixed or wired data connections and often have a measurably higher latency. This can lead to long retrieval times, especially for lengthy content. Also, many connection failures occur because of transmission interference (e.g., weather and terrain obstacles) and noise. Furthermore, mobile data transfers are often expensive and require additional power consumption. All of these limitations become important challenges in a mobile application that requires persistent communications with a server. Therefore, in order to provide acceptable quality of service to users, applications have to be context-aware, which requires them to adapt to context changes, such as exhaustion of battery power or constants failures to internet connectivity.

In this article, we suggest a middleware for client-server mobile applications. We assume that the middleware at the server-side has no resource restrictions, whereas at the client side it is light and does not incur much overhead to the applications. The applications running on a mobile device require a network connection and a communication protocol to access to the remote server and obtain some information. For this type of applications the accurate and fast response from the server is also a performance key actor. Besides, the connection method used to access the network can also affect the application efficiency. We will discuss what might be the best methods of communication, conjugating low traffic over the network and the simplicity to implement the whole system.

1. Challenges

New mobile computing devices (also known as pervasive or hand-held devices) are appearing everywhere. Despite the fact that growth in mobile devices and emergence of pertinent technologies paves the way for rapid growth in mobile wireless communications, the adequacy of the provided services is not the best. Poor reliability in today's wireless networks greatly inhibits (sometimes, to the point of infeasibility) supporting applications that involve efficient access to the WWW and Web Services.

Mobile solutions can be built in many different ways, used on many different devices, operate over many different networks, and integrate with many different back-end systems. The task of building a mobile solution can often be daunting given the many technology choices and implementation approaches. As we move from large, centralized systems to client/server systems that use a mixed bag of LAN-connected hardware, we need to optimize our programs for the new environment. This means we need to consume less network traffic in communications between clients and servers, to combine on less costs and better performance.

We have based our work only on client-server applications, where there is a need for a distributed environment and the communication between the distributed entities is

crucial. Here, we evaluate application speed, which is highly related to network speed, server and mobile performance. Additionally, there are many business factors that need to be considered. For example, who are the target users? How critical is it to have the latest data? Are there restrictions for storing data on the device? What countermeasures are there in case of no network connectivity? Is it a critical application?

In this sense, the following challenges must be addressed [2]:

- **Interfacing Disparate Technologies** - when different technologies are used (e.g., Microsoft .NET, Java), they must communicate seamlessly with each other;
- **Device Configuration** - since different manufacturers use proprietary methods for loading applications and configuration settings, the application should provide a menu for configuring all device settings required to the application;
- **Software Deployment And Upgrades** - deployment and remote configuration in several mobile devices should be available (e.g., automatic updates);
- **User Interface Design** - the graphical user interface (GUI) on a mobile device presents challenges due to small screen size and the difficult data entry interface;
- **Performance** - by comparison to desktop computers, many mobile devices are very slow, which implies special care in the application design and when dealing with complex algorithms and interfaces;
- **Memory Management** - since most mobile devices come with a fixed amount of memory that cannot be upgraded, an efficient handling of data is imperative;
- **Security** - losing the device and allowing a stranger to access sensitive business data are some of the security issues introduced in mobile system.

Besides all the previously enumerated challenges, when selecting the platform for the device, we can see three different types of applications [4]:

- **Online Applications** (also known as a thin client). This is client software, normally a browser, used when connectivity can be guaranteed. Without a connection, the mobile application does not work;
- **Offline Applications** (also known as a thick client). This is client software installed locally to the device that holds all required data for the duration of most operations, and synchronizes at the end of each day or after a preconfigured period of time;
- **Occasionally Connected Applications** (also known as a smart client). This is client software installed locally, similar to the offline model, but where the application can update and refresh data at any point in time. The frequency of the data refresh depends on the criticality of the application.

The continuous need of advanced services on mobile phones makes the traditional mobile terminals, based on closed software platforms, not appropriate to deliver new applications for supporting advanced services. For this reason, the mobile terminal software stack becomes always more open to host new applications as happened with personal computers. Due to this trend, also the programming environments and paradigms became closer to that of personal computers as well as the understanding operating system features [5].

Summarizing, the technological choice for programming a distributed application has different degrees of freedom: (i) application framework/OS, (ii) required computational resources, (iii) distributed programming paradigm and environment, (iv) communication among application fragments, (v) security.

2. Proposed Solution

We propose a solution that has been implemented in a system that aids the tourist in planning his travel and staying, according to his objectives, preferences, knowledge, budget and staying period. Such a system replaces the need to look for guide prospects/bulletins which sometimes can be quite confusing, or having to follow a standardized plan which does not fulfill his/her needs. It focuses on personalized sightseeing tour recommendation, based on tourism profile and recommendation techniques integration creating a personalized itinerary for holidays, based on user preferences and tastes. It recommends sites to visit, restaurants to eat and hotels to rest. Also, if necessary, the system provides a detailed and scheduled itinerary.

Because the worker can't always carrying his computer, he needs a tool that can be at his pocket, and ready to help and assist him when he needs. In this case we have a smartphone running the Android OS. The problem is that Android uses Java technology. There are two different modules, implemented with different technologies that need to communicate. Another issue is the low RAM memory capacity: only 288MB to the whole system, so we need to be very careful with the mobile application development. On the other hand, this PDA is equipped with HSDPA/WCDMA interface that allows up to 2 Mbps up-link and 7.2 Mbps down-links speeds.

Since the system uses Microsoft server-side technology and our mobile device uses the Android OS (Java technology), we need to specify a communication protocol for the mobile device to connect to the system. The objective is to give real time support to the user, indicating what to see or to do. For this system, that has maps, to show location and context aware information to the user, and involves big amounts of data in client-server communications, we suggest a solution where all the referred issues are taken into account.

This mobile device will run the Mobile Client Application. There are many considerations at this tier, including data availability, communication with middleware, local resource utilization, and local data storage. In addition, many business factors need to be considered.

Since we have two different technologies communicating with each other, and the base system is already implemented, we must implement a middleware application that bridges communications between these applications. This means that the mobile middleware will play a crucial role on the system.

Some of the important features of this tier include security, data synchronization, device management, and the necessary support for multiple devices.

When extending an application on to mobile devices, the challenges mentioned in the previous section need to be effectively addressed. The architecture needs to consider components that work in tandem to address these challenges.

For the communication protocol we will use sockets to transmit HTTP requests and responses when internet connection is available. Because this will be an occasionally connected application, a temporary database is used on the mobile device to permit access to parts of the data without constant traffic consumption over the network, and to allow the application to work without internet connection (with multiple limitations, of course). The middleware is in charge of all of the data synchronization, between the system and the mobile.

The architecture, presented on figure 1, can be summarized saying:

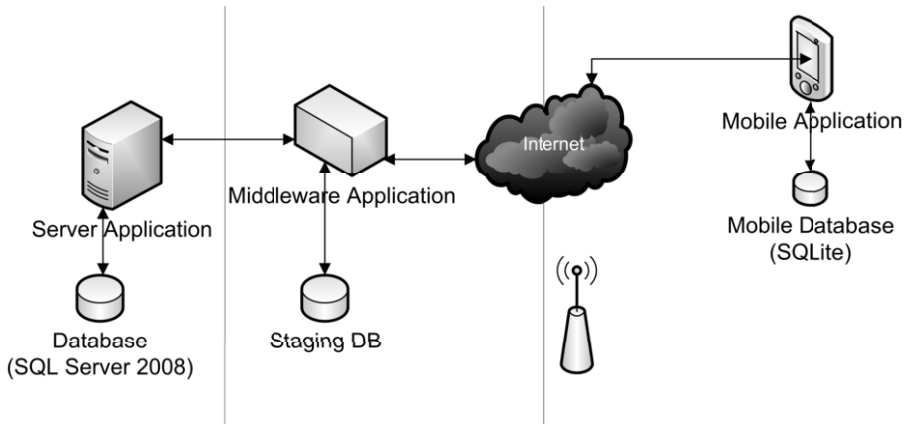

Figure 1. Mobile Architecture Description

- That the existing system will not be changed;
- Middleware application is a component that will reside on the enterprise end and will be developed on .NET Framework, with directives to permit the communications between the existing system and mobile application; a user authentication at the system; a data synchronization service between the system and the mobile device and a data access manager with a staging database; and a device manager, to permit updates of the application on the remote devices;
- Mobile application runs on Android devices and is used to capture/send data from/to the field. The application also has a synchronization component to synchronize the handheld data with the server database. Also, it contains a communication manager that is responsible for the communication protocol with the middleware application, accepting responses and making all the requests; a temporary database is used to enhance the application performance, besides the other necessary layers;
- Internet connection is used to retrieve/update itinerary information, costumers information, personal preferences and to get maps for orientation on site, based on location by GPS;
- Data is uploaded and downloaded automatically without user intervention; latest data is available to the user via background synchronization.

3. Details

We have presented a general overview of system architecture. Now, we present some application details, namely, why we choose some techniques instead of others, and a list of best practices to adopt when developing this type of applications.

To implement a good solution, it is useful to have a list of best development practices. Here is the list that we follow in our case study [4]:

1. Use Database Stored Procedures to write wrapper code for faster data access;
2. For ad-hoc data, the data should be populated using database views for faster output to the device;

3. The staging database infrastructure could be part of the main database server for faster response to mobile devices (the benefit is dependent on the number of users and the server load at any point of time);
4. While extending data from the back end to the staging database, include only those columns and fields that are necessary on the mobile device as the same is to be extended on to the device. This will help in adhering to size constraints on the device;
5. The staging database should only have data for a limited period (two months, for example) with regular scheduled archives; constraining the size of the database will reduce seek time;
6. Use the record version number to easily track records for delta updates during synchronization;
7. Use mapping tables in the staging database to track record version to facilitate conflict resolution; for example, to impose a conflict rule, overriding a transaction record with a server-side change even when multiple changes are done on the client end (A mapping table is a table in the staging database which contains the primary key of the back-end database table and the primary key of the record on the device database.);
8. The Data Exchange Service should be a recurring process and should be configurable in the middleware console to handle continuous changes on the back-end system and staging database (triggered from client), creating an asynchronous method of working;
9. Maintain only necessary user details on the middleware and link to the enterprise directory service for authentication and other user data. This will reduce out-of-sync issues for user information between the enterprise directory and the middleware;
10. Do not store passwords in the staging database; instead, query the enterprise directory service during authentication. This eliminates out-of-sync issues caused due to non-update of the server-side password in the middleware;
11. During synchronization, the client application should first check for application updates by sending its current version and downloading the latest version if applicable; this is an optimized mechanism for application version management;
12. Store the user device profile (device platforms and OS versions) in the user database and push version updates to the device accordingly, sending different builds to different users;
13. Maintain three tables: in-queue, out-queue, and user-wise out-queue for synchronization management, simplifying queue management and optimizing the synchronization process;
14. The communication manager can be made to try alternative types of connectivity when the primary method is not available, so as to use the most efficient available network connectivity option. For example, when wireless LAN is not available, the application tries General Packet Radio Service (GPRS) network; if GPRS is not available, the client does not synchronize;
15. The background sync interval should take into consideration the number of users and the number of concurrent users the server can support. These considerations will assist in reducing the load on the server supporting the maximum number of mobile users;

16. The Device Synchronization Manager just needs to send the username, device application version, sync interval time, and the delta updates during synchronization. To reduce the number of concurrent synchronizations, the middleware should return whether an update is available and the next time for synchronization if no update is required;
17. The record state column should be maintained at record level for faster composing of data during synchronization;
18. The applications should be designed in such a way that when the battery power is low, background thread priority should be set to low, reducing CPU usage and extending battery life;
19. Where the application consists of multiple screens having common UI parts and functionality, design a base form that contains the common elements;
20. Use frames instead of multiple forms wherever possible for faster user interface response;
21. Messages (such as error messages and alerts) should be configured in the middleware and should flow to the devices. Other configuration files should also be configurable on middleware and then pushed to the device application for use;
22. Database-specific queries should not be hard-coded; instead, the queries should be fetched from the middleware via a configuration file.

All these strategies force the applications to execute following some necessary principles in order to guarantee some properties. The following list contains some of the main advantages of our model.

- Scalability: the client side of a middleware is light and introduces a minimum overhead to applications and data communication network. It is possible to distribute the computation on the server side among different platforms;
- Openness: applications are "modules" that can be inserted and removed at any instant, even during runtime. Authentication, persistence and localization modules can be easily updated;
- Heterogeneity: the client side is robust and can execute on different platforms of mobile devices such as PDAs and smart phones. On the server side, the middleware can also execute on different platforms. The only requirement is to have a TCP/IP connection between those platforms and only the gateway needs to have a wireless link to communicate with the clients;
- Fault tolerance: the server side can be distributed, in order to overcome machine failures. In case the gateway fails, another entity can be configured to assume that same role. Also, redundancy can be obtained with multiple instances of the same server application. The client side deals with disconnections and reconnections in a transparent way;
- Resource sharing: multiple mobile clients can use storage of application servers, which can access a common database provided by the persistence module. Server applications share the gateway data communication link, which possibly has a larger capacity.

With these tips, we designed the architecture presented on figure 2. Here we give a detailed description of what each module can do. Starting with the middleware component we have the following modules (we give the name of the module followed by its functionalities):

- Data Access Manager - Consists of the piece of code that communicates with API's of the recommendation system, to insert, update and delete data and have preconfigured methods that return ad-hoc real-time data to the mobile device;
- Staging Database Management - This module manages the data that is at the staging database, where a replica of all transaction tables with mobile users is stored. It handles in-queue, out-queue and data archiving. Because data conflicts may arise, this module is responsible for gracefully manage and handle those conflicts. Database synchronization is also possible through this module;
- Data Exchange Service - It's the most important piece of software at middleware component, this service is responsible for bridging communications between applications. Compose messages to be sent from the back end to the mobile device and vice-versa, sending data to the out-queue, picking it from the in-queue, and use the received messages from the mobile device to call the Data Access Manager. To have effective data exchanges data optimization and a security to data introduction is necessary. All the transferred data is compressed, to consume less time on the data transmission between middleware and the mobile device. After the data is compressed it is encrypted for security;
- Middleware Console - Contains business logic to do specific activities that are not part of the middleware core, but part of the mobile solution. In this case it gets location updates captured from the device and uses them to retrieve maps to help the tourist. It also has a user interface for configuring middleware, allowing the configuration of modules such as user management, data sub setting, synchronization management, device management and so on;
- Device Management - It helps the management of the devices remotely; sends new application updates to the mobile devices; allows viewing application logs; explores device-related issues, to help solve problems remotely;
- Data Synchronization Service This is a core component of the middleware. Incoming data from the mobile device is received into the in-queue and the outgoing data is pushed to the mobile device from out-queue. It has background synchronization from the device and maintains a user-wise queue and checks for new records to be sent to the mobile device;
- Authentication Service - Manages mobile device users through a user list that is linked with the main system for users to use the same authentication on mobile devices. Also, it authenticates the mobile user during login process and synchronization, and has the capacity to handle multiple connections at the same time: from mobile users up to a maximum number of concurrent users.

On mobile side, we have the following implemented modules:

- Communication Manager - Establishes connection to the network and optimizes the way data is sent to the middleware (Compressing and encrypting the data). It is also responsible for authenticating a user with the middleware if there is network connectivity, otherwise authenticates with credentials available locally;
- Device Synchronization Manager - Sends and receives data from the synchronization service in the middleware, downloads application updates. Schedules background synchronization from mobile device sending data to the server at a pre-configured interval without user intervention (automatically), ensuring that the mobile client back end are in sync;

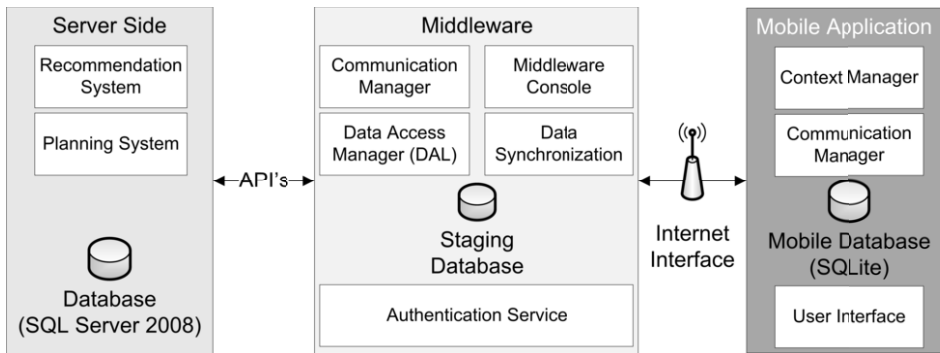

Figure 2. Detailed Solution Architecture

- Remote Data Access - Calls the methods defined in the Data Request Manager to have real-time data on the mobile device; if connectivity is not available then data existing in the device is used;
- Local Database Manager - Manages data in the device database, applying and composing the data. It is responsible to clean up temporary data from the database;
- Device Management - Is the complement of the Device Management module at middleware side, it executes commands from middleware, applies the application updates. Send application logs to middleware and if necessary it is capable of locking the application if the user enters wrong password for a specific number of times;
- Device Application - It is the face of the mobile solution it validates the user input with some business rules and interacts with external hardware interfaces attached with the device.

One of the most important aspects that must have a good performance is the data transfer. Here is where all the communications will stand. If data is carried faster, it means a more responsive system and less costs of internet traffic. It plays a significant role in mobile application architecture because of the number of 'hops' the data must make. The methods and protocols should be carefully considered during system design - see figure 3. There are several considerations to take in account regarding security. If the application is run on a secured LAN, then security restrictions may be little, otherwise restricting access to critical resources is a must. If cost and ease of implementation are imperative factors, then a less reliable method may be used. If reliability must be guaranteed, then a more expensive communication mechanism should be considered.

There are several choices for network communication. We will give a list and discuss the advantages and disadvantages of some of them, starting with the most recent communication protocol, Web Services. Web Services are relatively easy to implement and, if well implemented, are platform independent so they can be used between most platforms and technologies. They are not well suited for large, binary data files. Security is available, but may be more difficult to implement between heterogeneous technologies. It offers maximum portability and readability, but performs extremely poorly, particularly with mobile devices due to the limited bandwidth and processing power that they are able to provide.

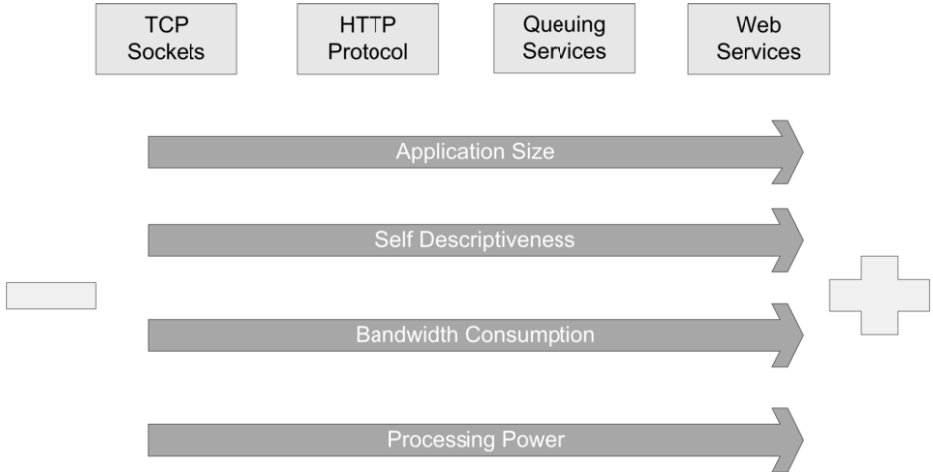

Figure 3. Comparison chart of different communication protocols

The Web Services protocol is very flexible, which is why it has established itself as the de facto standard for remote procedure calls in XML over HTTP. Unfortunately, the inherent disadvantage for the mobile segment in particular, is that it comes with plenty of overhead.

Bringing some major advantages, there are the Queuing protocols. These services guarantee data delivery. They may also be configured for store-and-forward capability. There are few queuing packages available for mobile devices and may be cost prohibitive. Queuing technologies for servers are well established and several good choices exist.

Another well-known protocol is the HTTP, which can provide an easy way to send and receive data. SSL can easily be used to provide security and the implementation is not complicated and very standardized.

Going further into some low level protocols there are the raw TCP/IP sockets. Transferring data over a raw network socket offers the greatest speed of all methods. If security is required it will need to be implemented in code, usually with an encryption library. Implementation can be quick if only raw file transfer is required, but there are many issues that need to be addressed. Multithreading will be required on the server so that multiple devices can connect simultaneously. If something far more complex than simple file transfer is required, another method (such as web services) should be considered since the specification of a new custom protocol over TCP/IP might be time consuming. The major advantage of this form of communication is its high transmission efficiency and the compact payload size. Its disadvantage, on the other hand, is that it is not self-descriptive, and also prior knowledge of the format in both the client and the server is required before the application development can even be initiated. This naturally results in a non-flexible implementation where any changes made to the message format must be consistent between the client and the server. Besides, with the increasing number of dissimilar messages that the server needs to handle, the program code becomes increasingly complex. Bringing some major advantages, there are the Queuing protocols. These services guarantee data delivery. They may also be configured for store-and-forward capability. There are few queuing packages available for mobile devices and may be cost pro-

hibitive. Queuing technologies for servers are well established and several good choices exist.

Another well-known protocol is the HTTP, which can provide an easy way to send and receive data. SSL can easily be used to provide security and the implementation is not complicated and very standardized.

Going further into some low level protocols there are the raw TCP/IP sockets. Transferring data over a raw network socket offers the greatest speed of all methods. If security is required it will need to be implemented in code, usually with an encryption library. Implementation can be quick if only raw file transfer is required, but there are many issues that need to be addressed. Multithreading will be required on the server so that multiple devices can connect simultaneously. If something far more complex than simple file transfer is required, another method (such as web services) should be considered since the specification of a new custom protocol over TCP/IP might be time consuming. The major advantage of this form of communication is its high transmission efficiency and the compact payload size. Its disadvantage, on the other hand, is that it is not self-descriptive, and also prior knowledge of the format in both the client and the server is required before the application development can even be initiated. This naturally results in a non-flexible implementation where any changes made to the message format must be consistent between the client and the server. Besides, with the increasing number of dissimilar messages that the server needs to handle, the program code becomes increasingly complex.

For our implementation we will use TCP/IP sockets (because of their performance boost), with data compressed and encrypted and a checksum algorithm to confirm the integrity of the data. The big deal will be the descriptiveness of the messages. One possibility is to send an XML file instead of pure binary text, but it requires more processing power at the client side (mobile device), and we really want to avoid that. We can say that the specification of the custom protocol will be time consuming, but will bring performance advantages in the future.

A custom protocol will be specified where the client application can invoke remote services provided by the middleware. A queuing service will also be implemented on the middleware, to manage the incoming and outgoing messages. In a distributed server-side environment, the middleware can communicate with the other server modules using web services. This way the mobile device communicates with the middleware using TCP/IP raw sockets, while the server-side distributed communications use web services. This kind of approach turns the middleware into some kind of enhanced proxy.

4. Related Work

Research in the area has been growing and there are several studies [2], [3], [4] and [6] on how to complement a business application with a mobile part. There are development tools that provide specific support for mobile device development like Eclipse and IBM WebSphere Framework [3]. We took some ideas from previous research and best practices to implement the middleware in our case study. Still, public research on the communication aspects involved between mobile devices and a middleware or business layer is still lacking. Knowledge about what is the best protocol to transport information, in an easy and effective way is the concern of many modern software enterprises that are cur-

rently developing for mobile devices. Having in mind the importance of such knowledge, we give our own contribution to the mobile community.

5. Conclusions and Further Work

In order to provide mobile capabilities to the worker, outside the office, while traveling or at home, delivering him all available business knowledge, under the form of a recommendation to a specific situation, turning business decision an easy process we have proposed a system to connect the client (mobile) application with the currently developed server-side. The final solution contains three parts: the actual server side system, a middleware component and the mobile application.

We examine aspects of mobility that distinguish mobile client-server interaction from its traditional counterpart. We also provide a comprehensive analysis of new paradigms for mobile client-server computing, including mobile adaptation, extended client-server model, and mobile data access. A comparative and detailed review of major research prototypes for mobile information access was also presented.

For this work, performance was one of our biggest concerns, as well as the reduction of traffic over internet cost. In further work we intend to implement and test the multiple communication protocols that we have presented, between mobile devices and middleware. This way, a more concrete analysis of the performance and effectiveness of the different protocols can be submitted. Also, flexibility, as well as implementation time and difficulty are some of the major future concerns.

References

- [1] A. Almeida, Personalized Sightseeing Tours Recommendation System, The 13th World Multi-Conference on Systemics, Cybernetics and Informatics: WMSCI 2009, Florida, USA, 2009
- [2] R. Schuler, Mobile Application Architecture, Enterprise Architect, 2007
- [3] D. Bevis, P. LindaMay, Extending Enterprise Applications to Mobile Users, IBM Mobile Computing Solutions, 2002
- [4] K. Hariharan, Extending Enterprise Applications to Mobile Devices, The Architecture Journal, 2008
- [5] F. Fummi, S. Martini, G. Perbellini, F. Ricciato and M. Turolla, Embedded SW design issues for distributed applications on mobile terminals. Mobile and Ubiquitous Systems: Networking and Services, 2005, 507 – 509
- [6] J. Jing, A. Sumi Helal, A. Elmagarmid, ACM Computing Surveys, Volume 31, Issue 2 (June 1999), 117–157

Open Source Based Concept of Intelligent House

Miroslav BEHAN^{a,1} and Ondrej KREJCAR^a

^a*Department of Information Technologies, Faculty of Informatics and Management, University of Hradec Kralove, Czech Republic*

Abstract. The evolution of cheap and ubiquitous sensors, chips and mobile devices lead to empower smart home environments where personal automation will reach conform potential of intelligent houses. The users and families benefits from sustainable, modular and social single smart interface where could interact their needs. We propose Smart Home point as Open Source solution for every intelligent house as low cost system with remote, social and sensorial control.

Keywords. Home, Automation, Smart, Social, Sensor

Introduction

Smart Home Point is open source system which for free to install in any building where habitants are looking for easy, comprehensive and social connected user interface with their home place. The system enables monitor, control and socialize householders with their facilities, families and friends. The monitoring covering any useful sensor which could be connected via Ethernet network such as motion, light intensity, temperature and other ambient sensors as well as voice, video or another signal readers. The controlling enables door locking, heating, air-conditioning, lighting and networking management on spot or remotely from mobile device or web browser. And mentioned socialization feature ability of system enables creates new interactive environment within home users who are identified by over their personal mobile devices and could share their social channels.

The cost of chips and sensors will reach ubiquitous level soon and we will interact and provide sensorial data to our environment. The smart environment at home will have for us more attractive background due to human social and personal behavior needs. Our relaxation, comfort, social zones will increase their efficiency thanks to intelligent sustainable environment. The houses will manage energy from recoverable sources and provide free of charge sustainable ecological live support without waste. The challenge is more than contrived where limited resources are drained in meaningless outcome in terms of human society. Therefore we propose sustainable open source project called Smart Home Point where all house management needs are connected in a single user interface ready for any customization.

We consider nowadays computational challenge as personal automation before at early stages of computational era that was industrial and after business process

¹ Corresponding Author: Faculty of Informatics and Management, University of Hradec Kralove, Rokitanského 62, Hradec Králové 50003, Czech Republic; Email: mirek.behan@gmail.com

automation where part of decision making is provided by computer or non-human computation power. There are two factors which enables such opportunity as wireless communication and mobile computing. Both in time will became the main stream providers of personal daily bases solution resolvers or advisers in terms of location, society or other contexts. Also the human interaction with the system is considerable as mandatory where visualization and control of human environment functionalities would be as one undivided unit which keeps purpose and sense of information.

1. Problem Definition

The main problem of smart home systems we consider in closed based solutions which are impossible to merge in low cost or at all. There is no open standard for smart sensors, applicants and Human-Machine Interface (HMI) at level of plug & play capabilities where house owners just plugin equipment in current sustainable system and it just works [12-14].

There are many sophisticated commercial solutions nowadays from companies which have to provide closed solution due to their survival on market which is leading to support non adaptive and dependable on mostly one provider of given solution. There is missing open based communication protocol which enables connect independent units into system on the fly. The part of problematic is in energy supply mechanism where for some applicants it is impossible to convert or to use low type consumption in 12V/24V voltage over unshielded twisted pair (UTP) cable and the power over Ethernet (PoE) is not an option. Other part of problem is in closed communication data exchange where designed protocols are dedicated to given solution and are unable to upgrade from third parties of manufactures or service providers.

There are also integration limitations of HMI in house environment [8] nowadays which in future will be transformed and known as intelligent walls, but current cost and technology well accepted are televisions with remote controllers. Therefore the challenge is about to integrate Smart Home Point (SHP) into current TV screens and among of house holders watched common content. Operating with such visualization is compound by usage of remote control technology or by usage of more convenient mobile devices as remote controllers where are the capabilities are much higher. Only disadvantage is battery consumptions of personal mobile device which may leads in such circumstances less usability of system.

Nevertheless due to such extend of home control there have to be covered the most common mobile platforms which are able to operate over wireless 802.11 [3] with system and present touch control functionality. Therefore Android, iOS and Windows Phone are considerable as mandatory for extension of HMI and native application of each platform benefits more usability of system.

The visualization relay to comprehensive and consistent user interface (UI) where text information is meaningless except numeric symbols in terms of simplification development process and interaction with international human [11], [15]. The principals of visualization are bound by nature of its meaning and functionality as an essence of pure knowledge expressed by 2D shapes and pictograms. Therefore the UI would correspond with real environment figure 1 and screen resolution accordingly to logical structure of building.

Other problematic of smart home environment is hidden in user's behavior and interactions which would morph current needs from system supportive to their actions.

The system would be capable of creating temporal social virtual space based on user personalities and intersected within group of users where intelligence surrounding environment became reality with real sense.

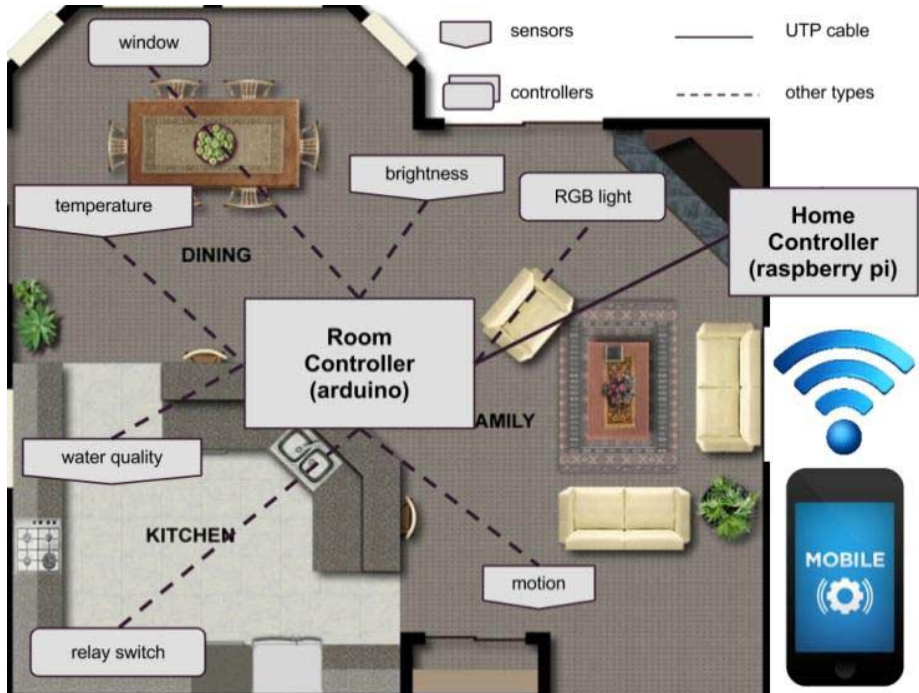

Figure 1. House overview schema – Ground floor visualization

2. New Solution

The new solution is based on open sourced and open electronics based technology within usage of Ethernet as informational and power supply medium. The core of system relies on Raspberry Pi [1] as a computational server which provides monitoring, controlling and visualization of modular units in smart home place. We propose open system prototype based on internet packet message delivery for monitoring and controlling house units over network and application interface designed to build independent solution, visualization and user control of system features.

The functionality of system we outline in figure 2 is about to merge house monitoring, controlling and personal social stream at one place. We provide administrator, householder and other user's profiles which over proper authorization process defined by OAuth 2.0 protocol specification are able to access smart home functionalities. In our solution we define house as a set of logical units which are equivalent to room or part of them. Every such logical unit has its own UTP cable and process controller which is connected in star type network. Data are transmitted over Ethernet and controller is supplied with power accordingly to 802.3af [4] where maximal 48V ~ 400mA limits possible applicants connected to controller. We choice Arduino [2] as such controller due to its open electronics principals, nevertheless it

could be any kind of dedicated Ethernet shield with logic circuits which is able to transform internet packet into electronics and backward transmit sensorial data over packets of designed protocol.

We propose communication protocol between room controllers or any other devices, applicants or some intelligent agents and visualization unit, master controller or mobile device which is equivalent as relation between in producer and consumer model. The messages from sensors are broadcast over local network, therefore any listener on specified port recognize sensorial messages and is able to take appropriate response. On the other hand commands have to be authorized by trusted controller and are broadcasted or directly sent to specific controller to provide expects actions. For instance lighting would behave on energy saving policy or on explicit user commands where broadcasting over whole building is possible. The communication is bi-directional where information distribution modeled as event is produced by every element wrapped into datagram as messages for broadcasting with content of status or measured values which could be listened on specific port. The datagrams are sent over Ethernet accordingly RFC 919 and 922 with Maximum Transmission Unit (MTU) 1500 bytes. The commands are encapsulated into datagram as message with type of command, values to be set and element identification. The datagram of commands is either unicast or broadcast dependable on destination of application. Following [Table 1] describes message definition between house unit controllers.

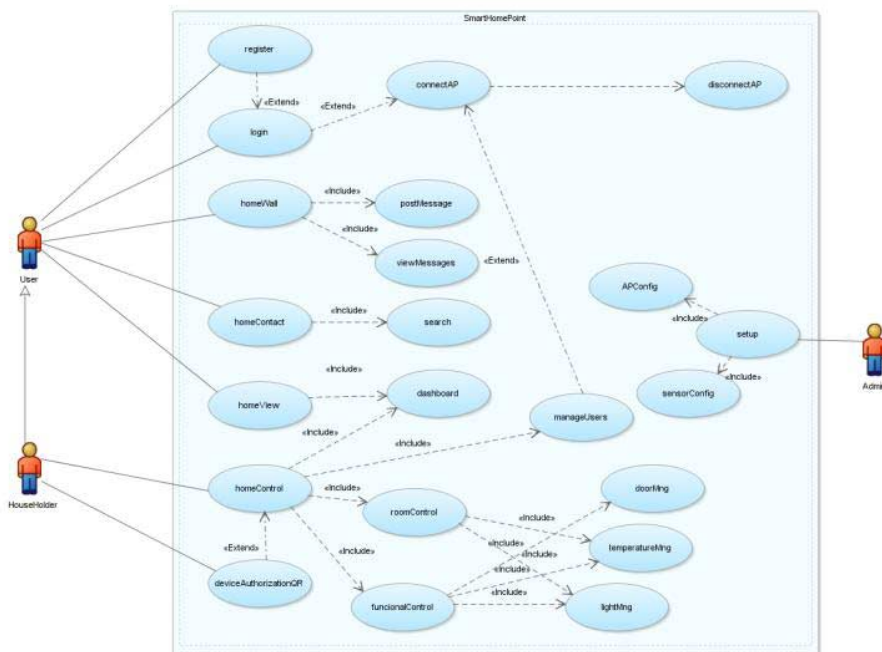

Figure 2. Use case schema of Smart Home Point

The electric signal from sensors is transformed into defined message type by controller considerable as the smallest home unit and broadcasted into local network. The magic field would be used as identification and authorization parameter of message source. Id field is incremental based stamp for synchronization and stream

purposes. The type filed defined message type whether it is Sensorial, Command or Confirmation message. Sensorial are generated invoked by sensor perception change. Commands are invoked from uses behavior or artificial knowledge and Confirmation type responses on commands with possible statuses. At last checksum and payload wraps content into JavaScript Object Notation (JSON) in case of necessity of structural data otherwise simple values like byte, int, float, double and chars not need structured bases and therefore simple chain of encoded chars are suitable.

Table 1. Message Definition of House Unit Controllers

Field	Data type/size	Description
Magic	uint32 / 4 bytes	Identifying magic value of type of message source
Id	uint32 / 4 bytes	Incremented stamp of message
Type	char / 12 bytes	ASCII string identified type of message
Checksum	uint32 / 4 bytes	Optional first 4 bytes sha256(sha256(payload))
Payload	char / ? bytes	JSON based values

The field of checksum presents integration capabilities with security option. We consider security in shared spaces where wireless access is possible and therefore this feature leads on higher performance of controller which have to also implements security check. The message itself is wrapped into Internet Packet and broadcasted over Ethernet in star schema deployment. The active nodes or controllers decide whether to broadcast further the message in other segments of network, therefore part of message delivery within system is based on correct network deployment. Following Figure 3 outline data model of system concept and from high level perspective define all data resources needed for basic scenario of house user needs.

As authorized commander house unit is any unit with computational capabilities with predefined magic values which works within system. In our case we use Raspberry Pi [1] due to cost effectiveness and openness capabilities. In different scenario that would be even mobile device or any other computer. Each commander house unit starts listening on specific port when it is deployed to system and stores history of messages. The history and statistical data are created based on time associated with recognized messages and their source. We provide in figure 3 data model annotated in Java Persistent Api (JPA) diagram where essence of gathered data are outlined. The Event and Command entity are expressing messages transmit in local network with their parameters. The element entity present all configured sensors or executable circuits with simple logic embedded within controller or have its own controller unit. Classic types of elements are predefined, but any other would be added and customized accordingly to specification. Controller represents basic building block of system which in our case represents Arduiono modules [2] suits due to its modularity and openness of electronics. The logic is programmed into the module which decides if sensorial message are broadcasted upon user location [9] and behavior [10] or ambient changes.

At last we outlined the interaction of building blocks of system where is highlighted informational view processing with authorization by secret token which enables view and controls of elements in system. The commander unit basically provides user interface interaction with other parts of system [16-17].

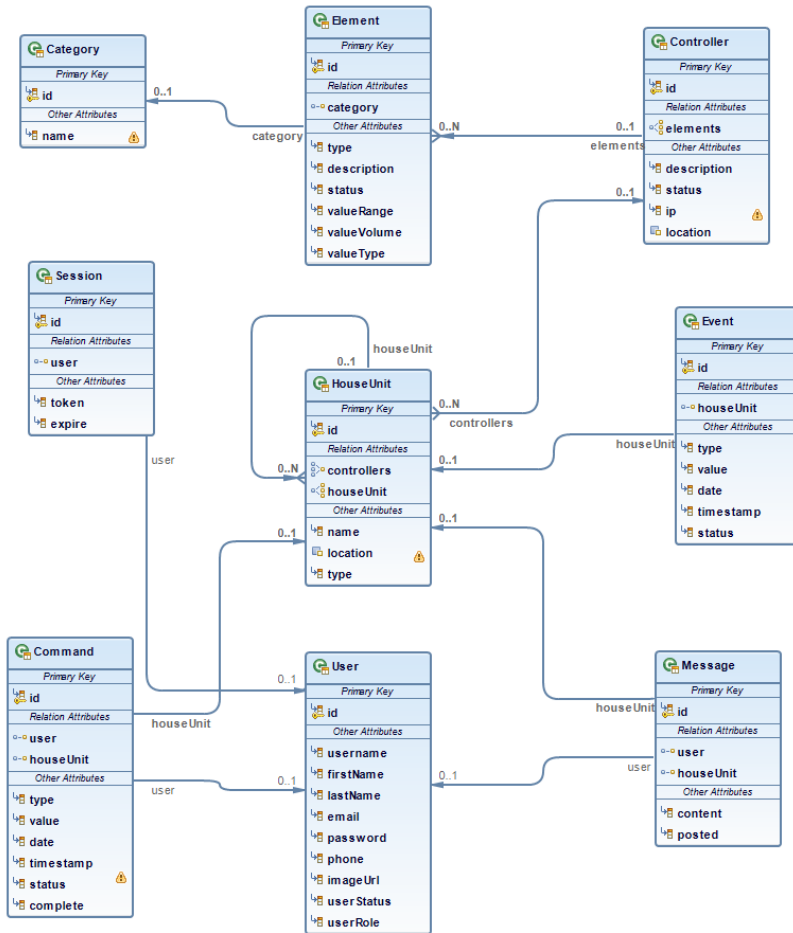

Figure 3. Data Model of Commander House Unit

3. Implementation

The prototype of system consists of Commander, Controller, Element and UI units. We consider Commander Unit as Linux based minicomputer known Raspberry Pi [1] where nonstop running web server responds for user’s mobile device and other UI applications. Also inner part of system is socket server bind with logic and database which listening on port 5000 for every event or command messages transported over local network. The communication with web server is provided by Representational State Transfer (REST) as web resource based access. The Application Programming Interface (API) describes main functionalities in following figure 4. We consider also third party access, therefore open based API access is provided and the documentation with mock’s objects available on web application [6]. API conforms to latest consideration of resource based best-practices where all types of resources if are allowed to access are able reach from top level hierarchy or from relation between

resources. The relations are expressed as inner mount point with identification of upper leading resource. The authorization to resource is provided by implementation of Filter class of web server where access privileges are defined in profile type of user and therefore resources are defined as accessible to specific type of profile. For instance Admin or Householder is able to add new user into system and authorize for him or her to executed commands.

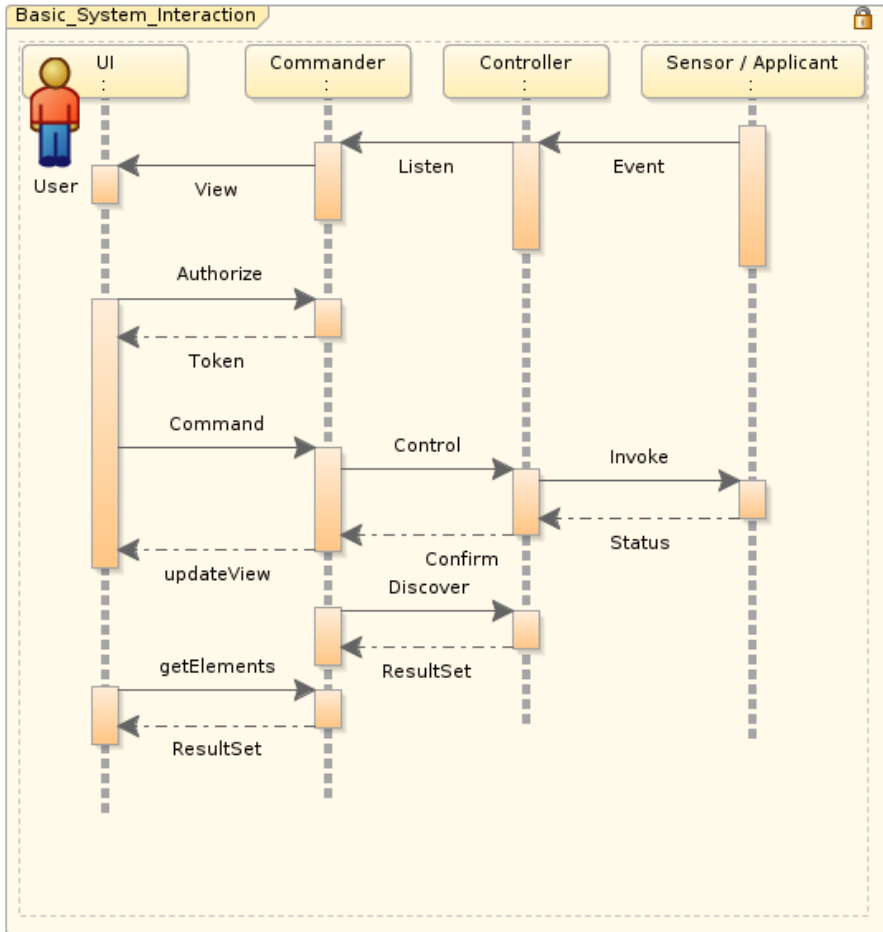

Figure 4. Interaction - Controller and Commander Units

We consider implementation on different mobile platforms as Android, iOS and Windows for UI application with simple user friendly component as a part of further discovery. Nevertheless nowadays we just propose open resource based interface which leads to correct implementation of mobile UIs. The practically are main resources User, Element, Controller, Command, Event and House which allows settings and maintaining system which was at first configured by technical person and provide proper setup of controller and commander unit. The User resource allows plain Create

Read Update Delete (CRUD) operation for authorized actor with resource. These are provided to all resources as generic plain implementation. The other operations as login, logout, findUserByKeyword, createWithArray or createWithList are provided for specific functionality where name or detailed description expresses their purpose defined by annotation on entity classes and generated on every request [6], therefore the API documentation is all the time up to date.

The solution is partially implemented and publically accessible from GitHub.com [7] where the commander unit is proposed and API for controllers is designed as blueprint for different platforms of mobile devices applications.

4. Conclusion

This project proposes web based Smart Home system realized by open technology and open source software solution as part of future intelligent house. The new solution provides connectivity between sensorial electronics signals and web resources with monitoring, controlling and visualizing elements in environment. The system is designed to be customized, upgraded and tuned by anyone under open source license.

References

- [1] Rapsberry Pi - <http://www.raspberrypi.org/> [Accessed 24.4.2013]
- [2] Arduiono - <http://www.arduino.cc/> [Accessed 24.4.2013]
- [3] Standard 802.11 - <http://www.ieee802.org/11/> [Accessed 24.4.2013]
- [4] Standard 802.03af - <http://www.ieee802.org/3/af/> [Accessed 24.4.2013]
- [5] SmartHomePoint - <http://www.smarthomepoint.com> [Accessed 30.4.2013]
- [6] API SmartHomePoint - <http://www.smarthomepoint.com/apiview> [Accessed 30.4.2013]
- [7] GitHub.com - <https://github.com/mirekbehan/SmartHomePoint> [Accessed 30.4.2013]
- [8] L. C. De Silva, Ch. Morikawa, I. M. Petra, State of the art of smart homes, *Engineering Applications of Artificial Intelligence*, Volume 25, Issue 7, Pages 1313–1321, October 2012
- [9] S. Zhang, Li Qi, The Solution of Smart Home Indoor Positioning Based on WiFi, *Artificial Intelligence and Computational Intelligence*, 4th International Conference, AICI 2012, Chengdu, China, 26-28 October, 2012
- [10] Z. Zainol, K. Nakata, Context-Based Interaction Design for Smart Homes, *12th Pacific Rim International Conference on Artificial Intelligence*, Kuching, Malaysia, 3-7 September, 2012
- [11] V. Kasik, M. Penhaker, V. Novak, R. Bridzik, J. Krawiec, User Interactive Biomedical Data Web Services Application. In ICeND 2011, August 03-05, 2011 Dar-Es-Salaam, Tanzania. *Lecture Notes in Computer Science*, CCIS Vol. 171. pp. 223-237. Springer-Verlag, Berlin, Heidelberg.
- [12] C.Y. Liou, W.C. Cheng, Manifold construction by local neighborhood preservation, In *Springer LNCS*, Volume 4985, 14th International Conference on Neural Information Processing ICONIP 2007, Kitakyushu, Japan, Non 13-16, 2007, pp. 683-692. 2007
- [13] L. Lhotska, M. Bursa, M. Huptych, V. Chudacek, J. Havlik, Standardization and Interoperability: Basic Conditions for Efficient Solutions. In *IFMBE Proceedings*, pp. 1140-1143, 2011
- [14] L. Hutnikova, R. Hudak, T. Toth, M. Michalikova, J. Zivcak, The role and applications of the databases in the process of implantology, *Lekar a technika*. Vol. 36, no. 2, pp. 236-239. 2006
- [15] K. Choros, Further Tests with Click, Block, and Heat Maps Applied to Website Evaluations, *Lecture Notes in Artificial Intelligence*, Vol. 6923, pp. 415-424, 2011
- [16] L. Longo, B. Kane, A Novel Methodology for Evaluating User Interfaces in Health Care, *24th IEEE International Symposium on Computer-Based Medical Systems CBMS 2011*, Bristol, England, June 27-30, 2011
- [17] L. Longo, B. Kane, L. Hederman, Argumentation theory in health care, *25th IEEE International Symposium on Computer-Based Medical Systems, CBMS 2012*, Rome, Italy, 20-22 June 2012

Intelligent House - Smart Living and Smart Workplace in Practical Approach

Richard CIMLER^{a,1} and Karel MLS^a

^a *Department of Information Technologies, Faculty of Informatics and Management,
University of Hradec Kralove, Czech Republic*

Abstract. People are currently spending more and more time in their homes, where they will also accomplish a wider range of activities, including professional work. The border between home-work and professional work is getting more traversal as greater number of activities is being supported by different kinds of Ambient Intelligence. Smart technology has changed the ways people work at home, with more virtual workspaces and the potential for constant wireless connection to one's work. While the conceptual description of the complexity of managing both work and home activities can be reached relatively fast, any successful model of work-home integration needs research on the spatial aspects of workspaces in the Smart Homes - physical environments, design and effective use of physical components such as sensors, controllers, and smart devices is vital. In practical part of the paper, hardware and software design and implementation of the system with basic functions for intelligent house management is described. The system enables the future extensions of its functionality in accordance with possible user requirements.

Keywords. smart home, smart workplace, ambient intelligence, work-home integration

Introduction

In 2001 ISTAG final report, four AmI scenarios were introduced as possible daily life and work experience around 2010, and since has been broadly cited and disseminated in many research publications, even though the practical implementation of the visions were not achieved yet.

Researchers envision a future information society stemming from the convergence of ubiquitous computing, ubiquitous communication and intelligent environments, especially residential environment. Junstrand in [1] observes that people are currently experiencing a major change in the way of living due to the transition from an industrial society to an information society. The key change is that people will spend more and more time in their homes, where they will also accomplish a wider range of activities, including professional work, Tele-educating, Tele-shopping, Tele-caring and etc. Therefore, the upcoming hypothesis is that the dwelling of the information society will have a different concept of space than the current dwelling. Meanwhile, the Smart Home concept represents an important step in this evolution, emanating from the all permeating information, communications and ambient intelligent technologies.

¹ Corresponding Author: Faculty of Informatics and Management, University of Hradec Kralove, Rokitanského 62, Hradec Králové 50003, Czech Republic; Email: richard.cimler@uhk.cz

In the future, people will execute an increasing amount of their everyday activities in and around the dwelling. The border between home - work and professional work will loosen up. A greater number of activities will also be supported by different kinds of Ambient Intelligence. Space in the information society is becoming more complex and can be understood as three spaces integrated in to a new concept of home environment where Virtual Space (VS) and Ambient Intelligent Space (AmI - S) is combined with Physical Space (PS).

- The Virtual Space (VS) consists of ICT appliances such as smart walls and smart furniture that are connected to an information network. It supports information - related activities, such as social networking, tele-shopping, tele-working and tele-learning.
- The Ambient Intelligent Space (AmI-S) refers to environments that are equipped with computers and sensors, in such a way that they can adapt to user activities through an automated form of awareness. This kind of space will improve physical - mental comfort and wellness. It will also assist daily activities such as cooking, sleeping, washing, eating and personal activities such as care taking of elderly and child caretaking.
- The Physical Space (PS), on the other hand, is the traditional space where people actually are with their bodies.

In practical part the article explores several commercial systems on the Czech market and based on the acquire data the architecture of the designed system is created. The article presents the description of hardware solution using .NET micro Framework modules FEZ Panda II and G120. Software for this system is composed in programming language C# and integrated development environment Visual Studio 10. The result of this implementation is fully functional system with basic functions for intelligent house management. The system enables the future extensions of its functionality in accordance with possible user requirements.

1. Smart Workspace within the Smart House

Throughout the past century, work space and home became increasingly distinct both mentally and physically. Work and private life were considered as separate spheres. But according to Leonard in [2], this trend will be reversed again by an increasing integration of the two domains. Increasingly more people are beginning to work from home either part-time or full-time. Changes to the nature of work including technological advancement, the introduction of flexible working hours and tele-working increasingly interweave work activities with home life. On the other hand, as Kennedy [3] remarked “the more time spent working at home, the greater integration and blurring of home and work boundaries will happen”. That is to say, that work-related activities on the one hand and private activities on the other will be integrated in future rather than be balanced as presently done.

In the paper [4] it is shown how work-life integration in the Smart Home is affecting the boundaries between work space and other living space. The most important advantage is that people do not need a specific space to make it work. Any corner in house may be suitable as a home office thanks to ICT and AmI technologies.

In such a scenario, some granted boundaries between spaces may dissolve and more negotiation around tasks may take place.

A number of shifting boundaries including those between work and private spaces in the house will be introduced. Due to these changes, an architecturally distinct area is no longer required and the separation of work space and living space is increasingly broken down and rearranged by “blurring boundaries” (Leonard, 2006). The former physical separation of work in public spaces and non-work in the private spaces of the home does no longer apply in the same way. Hence, smart technology has brought profound changes to the ways people work at home, with boundary less physical spaces, more virtual workspaces, and the potential for constant wireless connection to one’s work. The workplace is no longer necessarily a discrete physical location. While this level of integration is achievable by technological developments, the complexity of managing both work and home activities needs more researches to manage all “crossover” work activities at home [5]. Hence, any successful model of work-home integration needs research on the spatial aspects of workspaces in the Smart Homes.

1.1. Architecture of a Smart Home

Automation in a smart environment can be viewed as a cycle of perceiving the state of the environment, reasoning about the state together with task goals and outcomes of possible actions, and acting upon the environment to change the state. Perception of the environment is a bottom-up process. Sensors monitor the environment using physical components and make information available through the communication layer. The database stores this information while other information components process the raw information into more useful knowledge (e.g., action models, patterns). New information is presented to the decision making algorithms (top layer) upon request or by prior arrangement. Action execution flows top-down. The decision action is communicated to the services layers (information and communication) which record the action and communicates it to the physical components. The physical layer performs the action with the help of actuators or device controllers, thus changing the state of the world and triggering a new perception (Figure 1).

Because smart environment research is being conducted in real-world, physical environments, design and effective use of physical components such as sensors, controllers, and smart devices is vital. In any intelligent agent design, the physical components are what allow the agent to sense and act upon the environment. Without these physical components, we end up with theoretical algorithms that have no practical use.

1.2. Main Features of Home Smart Offices

The main advantage of ambient intelligent technology in the Smart Home is improving the level of flexibility in the ways of doing activities. Each home allows users to experience open and livable flow in the multifunctional smart zones. Rather than living in static and restricted rooms, the home promotes “flexibility in-between” for spaces. In other words, a Smart Home improves the possibility of spaces by technology and multitasking in each space while the physical elements of the space itself can be completely or partially fixed. The final result can be an open space with multifunctional zones equipped with some flexible smart furniture and devices which are networked.

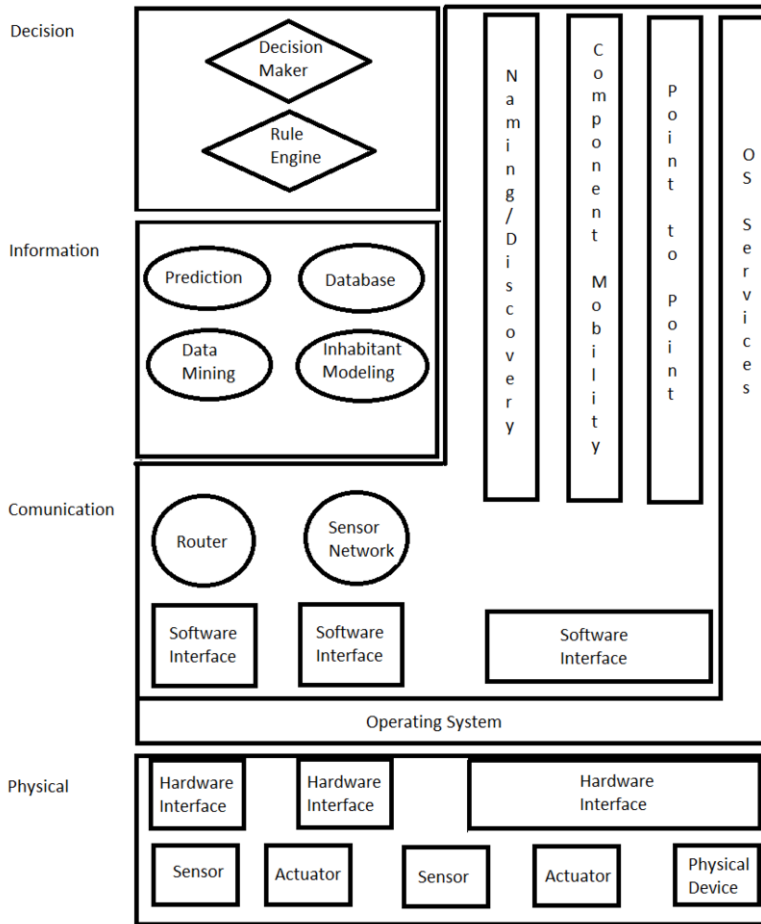

Figure 1. The components of a smart environment [6]

The possible contributions of smart home concepts and developments to space saving are:

- Reducing the need of distinct physical spaces for special activities. Activities are not restricted in space thanks to pervasive computing and data network,
- Reducing the need of distinct physical spaces for home office because of the integration between work activities with life,
- Reducing the number of devices in a house,
- Mixing several zones with each other and blurring the boundaries by multitasking,
- Use of virtual space instead of physical space by several tele-activities,
- Use of flexible and multifunctional devices and furniture,
- Improvement of the flexibility of spaces.

Such a “build better, not bigger” design approach is one the great benefits of the Smart Home.

1.3. Historical and Commercial Issues of Home Smart Offices

Interest in “wiring” homes for increased functionality dates back at least to the 1960s. At this time it was largely the province of home hobbyists, however, and most other people would have considered the description above to be science fiction.

By 1984, however, commercial interest in home automation had grown sufficiently for the National Association of Home Builders in the USA to form a special interest group called “Smart House” to push for the inclusion of the necessary technology into the design of new homes. Interest came principally from the fields of building, electronics, architecture, energy conservation, and telecommunications.

Since the 1980s, manufacturers of consumer electronics and electrical equipment have been developing digital systems and components suitable for use in domestic buildings. Important developments have included the replacement of electromechanical switching with digital switching, and of traditional twisted pair and coaxial cables by optical fibers. Other enabling developments are new communication networks (e.g. ISDN, Internet) which allow two-way communication, and new end devices (e.g. web TV, video phones)

Although the concept of the “smart house” was well established by the end of the 1990s, to date only a small number of expensive “smart homes” have been built and sold on the commercial market, in contrast to the rapid diffusion envisaged.

Many of these are simply commercial showcases with no research agenda. However, there are also a number of commercial projects actively exploring the possibilities offered by technology associated with the smart home, for example utility companies seeking to control domestic energy consumption remotely. These investigations are interesting because they can be regarded as experiments in the “real world”. Their drawback is that, where they are not academia-led and involve no social scientists, evaluation from a user-centered perspective may not be thorough. Furthermore, the findings may never enter the public domain.

2. Agile Architecture

There are a lot of companies specializing on the creation of the intelligent houses or integrating intelligent components into a house additionally. Cost of the implementation intelligence into the new building is estimated to 10% - 20% value of the whole construction depending on the level of the functions. Reconstruct old house and add intelligent components could be even more expensive.

Each company has its own know-how consisting of architecture of their solution and specialized software. Distinguished part of the value of the intelligent house is because owner of the house is buying also part of the know-how of the company.

Decreasing costs of the electronic parts and devices enable people to experiment and create their own solutions for different problems which can be solved by automation of some processes. Small systems with just an elementary functionality and simple purpose can be created quite easily with basic knowledge of electronics and programming. More time and effort can lead to creation of a complex system with extended functionality.

It is difficult to determine which house can be called intelligent and what is only humble automation of the some processes in the building. This topic was explored by many researchers and is discussed in large number of articles.

There are a lot of attitudes on question what makes house intelligent and what is only a humble automation of some processes in the building. This topic was explored by many researchers and is discussed in large number of articles. Following text describes more practical view on the problematic of intelligent houses. Intelligent house as well as only automatized system has to be based on some hardware solution. Idea of ubiquitous computing is to create systems which should help people with their activities without being noticed [7]. Design of system architecture which could lead to creation of the core for the intelligent house is presented in the following part of the text. This architecture can be easily extended and new functions can be added due to intelligent house requirements.

Micro framework modules are suitable solution for creation of the systems with basic functions. Systems composed of these modules can be further easily extended. Different companies offer these modules as well as many components with varied functionality. Modules and components can be easily connected to the system for additional functions. This agile system can maintain basic functions of the house and can be connected to computer which can provide more complex computation.

2.1. Architecture

Described architecture is inspired by commercial solution and our future research will be based on it. There is one control board - master and few extension modules - slaves. Control board can also communicate with connected computer. Quite cheap micro framework modules can be used for building solution with same architecture as commercial one. Systems could have various purposes and there could be also different demands on the system during its lifecycle and that is why modular architecture is appropriate solution. Simple functions can be handled by framework modules and more complex computation can be forwarder to connected computer.

Micro framework modules are programmed to maintain basic functions of the system. Various sensors can be connected to slave modules providing inputs into the system. Information from these sensors is forwarded by slave modules to the master. Software in the master evaluates these inputs and sends result into the appropriate device. This device can be one or more of the slave modules as well as computer connected into the system via LAN/WLAN. Slaves can execute appropriate action based on the information gained from control module. If master module doesn't have enough resources to run software necessary for evaluating some kind of inputs from the slave modules, inputs can be forwarded to other destination because of its connection to the LAN/WLAN.

Architecture of the system can be seen on figure 2. Components of the system are described in following text.

Sensor is component enabling system to acquire data from the environment. It could be for example thermometer or hygrometer. Sensors are directly connected by bus to one of the extension modules. Extension module forwards information from the sensor into the control module by bus. Each room can contain one or more extension modules.

Control element is a device such as a switch on the wall. This element communicates with extension module only if user wants to and therefore interacts with it - push a switch in our example.

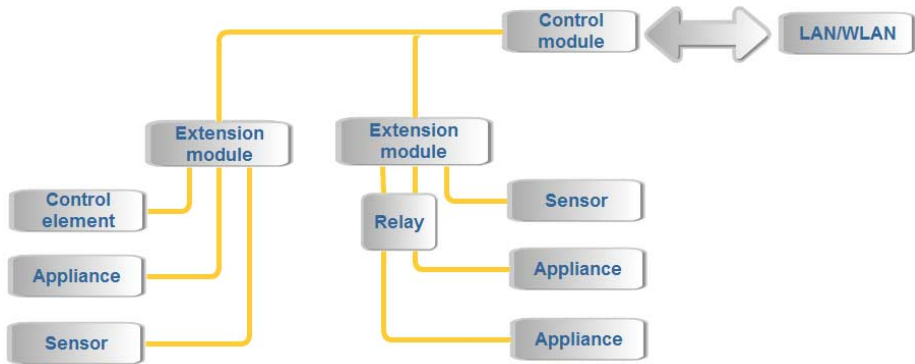

Figure 2. Architecture of the system

Relay is an electrically operated switch. Relay can control a circuit and can be operated by low-power.

Appliance is a device which can be turned off and on by extension module or by the relay. It can be for example light in the room or electric plug

Control board can communicate with extension modules and can be also connected to the LAN/WLAN.

Extension modules are connected to sensors, appliances and control elements and provides forwarding of the information

In the following part of the text the short introduction into the testing of the designed architecture is described.

2.2. Testing Designed Architecture

The micro framework modules created by company GHI electronic [8] has been used for the purpose of testing. Panda II (figure 4) and G120 (figure 5) have been chosen as a most appropriate devices. Both modules supports .NET micro framework. Parameters of each of them can be seen on figure 3.

	Panda II	G120
Processor	72 Mhz 32-bit	120 Mhz 32-bit
Flash memory	148 kB	2,87 MB
RAM memory	62 kB	13,67 MB

Figure 3. Parameters of the modules

G120 is a master module because of its better performance and Panda II is used as a slave module. Communication between devices uses CAN bus. CAN is originally designed for automobile industry and can prevent collisions in the communication.

Collisions can arise if there will be more slaves modules in the system. Communication between master module and PC is using HTTP protocol. HTTP provides easy communication with different devices as a smartphones or tablets. In our future work more specific communication protocol will be created.



Figure 4. Panda II [8]



Figure 5. G120 [8]

Simple application able to control the basic functions of the system has been programmed in .NET micro framework.

First test was sending information between devices. 100 messages containing identification number 1 were send from the Panda II to G120 and these messages were shown in the console of the G120.

Second test was connecting micro switch to the Panda II. Manual change on the switch called up an event and this information was send to the G120, where was message about the change of the switch shown in the console.

Third test was connection of the thermometer to the Panda II. All measured temperatures were correct.

All of three tests had positive results.

3. Conclusions

Theoretical aspects of smart living and smart workplace in one have been introduced. Agile architecture of the system for maintaining basic functions of the intelligent house was presented. Based on the presented architecture future research will be conducted. Agile architecture enables to create modular systems which can be used as a control unit of intelligent house. Software running on the computer can maintain more complex procedures and orders can be given to the control board via LAN/WLAN. Micro framework modules provides reasonable solution for creating system maintaining basic functions in the intelligent houses and forwarding complex events into the more performing devices.

References

- [1] S. Junestrand, Being private and public at home, An architectural perspective on video mediated communication in Smart Homes, Doctoral Thesis, Royal Institute of Technology, Stockholm, Sweden, 2004.
- [2] L. Leonard, D. Thorns, On-Line Workers Working From Home, Paper presented at the Sociological Association of Aotearoa New Zealand (SAANZ) Conference Hamilton, November 2006
- [3] T. Kennedy, J. Amoroso, B. Wellman, Blurring of home and work boundaries: integrating paid work, domestic work and family, Center for mobile communication studies, Rutgers university, New Jersey, USA, 2009.
- [4] R.T. Black, M.G. Brown, J. Diaz, K.M. Gibler, V. Grissom, Behavioral Research in Real Estate: A Search for the Boundaries, *Journal of Real Estate Practice and Education*, Volume 6, Number 1, 2003, pp85-112.
- [5] A. Sellen, J. Hyams, R. Eardley, The Everyday Problems of Working Parents: Implications for New Technologies, Hewlett-Packard Technical Report, 2004.
- [6] D.J. Cook, and S.K. Das, How Smart are our Environments? An Updated Look at the State of the Art, *Journal Pervasive and Mobile Computing* 3, 2 (2007), 53-73.
- [7] P. Mikulecky, Ambient intelligence and smart spaces for managerial work support, *Intelligent Environments*, 2007. IE 07. 3rd IET International Conference, 560-563, 24-25 Sept. 2007.
- [8] GHI ELECTRONIC, <http://www.ghielectronics.com/catalog/product/256>

A Multi-Agents Framework for Contextual and Affective Decision Making

Carlos Filipe FREITAS ^{a,b,1}, Goretí MARREIROS ^{a,b}, Ricardo SANTOS ^{a,c},
João BARROSO ^d and Carlos RAMOS ^{a,b}

^a GECAD - Knowledge Engineering and Decision Support Research Center

^b ISEP - Institute of Engineering - Polytechnic of Porto, Portugal

^c CIICESI, Escola Superior de Tecnologia e Gestão de Felgueiras, Instituto Politécnico do Porto, Portugal

^d UTAD - Universidade de Trás os Montes e Alto Douro, Portugal

Abstract. In an idea generation meeting, the facilitator role is essential to obtain good results. Also the emotional context of the meeting partially determines the (un)success of the meeting, being it of idea generation or decision selection. So the facilitator needs to obtain and process this information in order to assist the participants to reach their goals in different processes of decision making. In this paper is proposed a multi-agent framework able to be used in the support of persons in a affective context-aware and ubiquitous group decision process. Insights of the context-aware model are provided. It allows the gathering of certain typical variables of the affective context (emotions and mood) and transform those values in advises to the facilitator.

Keywords. Multi-agents framework, affective agents, affective decision making

Introduction

Intelligent or Smart Meeting Rooms (SMR) are a subdiscipline of Ambient Intelligent Environments [1] and are defined as environments that should support efficient and effective interactions among their occupants. Such environments should also understand what is happening between the participants including what is being discussed, as well as to support the decision making process considering the emotional factors of the intervenient participants and the argumentation process in order to supply intelligent feedback to users [2].

The Group Decision Support Systems (GDSS) emerge with the aim of helping the decision-making groups, supporting the decision-making process, and they can be any technology used to improve the quality of group decision-making. They run on the assumption that they can help groups to reach higher quality decisions, stimulate more equitable and useful interactions, and reduce the negative aspects of small group decision-making[1][3].

With that vision GDSS have been adapted and developed through the time, incorporating new features, and modifying their architectures. Due the costs to create

¹ Corresponding Author: ISEP - Institute of Engineering - Polytechnic of Porto, Rua Dr. António Bernardino de Almeida, 4200-072 Porto, Portugal; E-mail: caf@isep.ipp.pt.

conditions that allow participants to meet in the same place at the same time (time, travel, etc.) the ubiquitous GDSS (ubiGDSS) emerged as the natural evolution, providing to the decision makers the ability to contribute with their ideas to the decision process anywhere and anytime [3][5].

The work described in this paper considers the SMR vision and the current state of art we were motivated to provide a framework that could be used in meeting rooms and in other contexts where intervenient must take decisions in a group setting and possible in a distributed and ubiquitous way. A multi agent approach is taken. Affective agents are used to play different kind of participant roles and interact between them. Reactive agents are used to perform context data acquisition. The focus is to improve the capacities of the decision maker providing them a support to improve their decisions.

The rest of the article is organized as follows: the first section present the details of the decision process that we seek to support. In section 2 we described the proposed model and we explain the differences between it and the systems already existent.

1. Meeting Process Modulation – The context

Before explaining the meeting process in detail we need to clarify our understanding of the context. Any action or entity is linked to a context. An action depends on contextual parameters such as temperature or humidity of the context, which form part of the environment [6]. However, these parameters need to be specified.

The context may be divided into several categories and in that sense Hofer his colleagues [7] makes a distinction between logical and physical context:

- The physical context. It refers to the general context information. This information is captured by sensors and usually updated frequently to always have a value of the current situation.
- The logical context is related to the physical context. It is derived from reason and process the physical context. It is more difficult to obtain, more complex and more meaningful. User's mood or the appropriateness of context specific characteristics is examples of logical context content.

For the purpose of this study the meeting setting context was issued. Here by the physical context can be seen as the meeting process itself and the logical context, which occurs in the meeting physical context, can be seen as the participants' interaction for the discussion of the problems that leads the meeting to a solution. The emotional state of the participants is seen as one more item for the evaluation of the logical context.

About the process is possible to say that a meeting is a consequence or an interaction objective between two or more persons (teams, groups) which can be carried through one of four possible environments: same time / same place; same time / different places; different times / same place; different times / different places; and where participants take the initiative of writing everything that is relevant for the discussion they are having. It is widely accepted that in a group meeting there are two types of roles involved: the role of the facilitator and the role of the participant. Some authors argue that the facilitator should be a neutral person. However, he is always pointed as a meeting participant and sometimes as part of the team. Participants are members of the group who perform decision making in meetings and have to cooperate in order to execute a specific task [2][8].

Other feature of meetings is their purpose. From the tasks model proposed by McGraph [9], who classifies the tasks performed by a group in categories which are the generation, choosing and negotiation of alternatives and execution, we seek to support the first three which will be analyzed in more detail in the following sub-sections.

1.1. Idea Generation and Decision Support

Idea generation is strongly related to creativity that is usually seen as a process to create something new or to add value to products and services of a company [10].

Regarding the group idea generation process the ideas generated arise in an emergent way, i. e. were the exchange of ideas between participants is supposed to lead to new ideas. An idea generation meeting consists of two elements: the participants and the facilitator. While the first one has the goal of generating ideas, the facilitators have a more complex and critical mission. According to Nunamaker et al.[3], the facilitator performs four actions: to give technical support to use the applications of idea generation support; to mediate the meeting, to maintain and update the meeting agenda; to help in the planning of the agenda; and finally to give organizational continuity, to define rules and maintain an organizational store.

This process is already modeled in a form of an extensible ontology, the Meeting Task Ontology (MTO) that is able to represent in detail what knowledge exists in Meetings for group decision-making. This ontology was already extended by the IGMTO ontology that specifically focuses in the Idea Generation (IG) Process. Both are introduced as a middle layer necessary to model the physical context of meetings. The authors actually mention two other layers out of the scope of their proposal but that are used. They are, on the down layer, generic ontologies already proposed in literature to describe a smart space, and it gathers time and space features and which they reuse. And a top layer that includes a domain of speech ontology to who they include properties to interconnect with their proposed layer. [2][10]

According to the literature, it is possible to conclude that the emotional context of an idea generation meeting influences the performance of the participants. In several studies found in the literature prove that when a group is generating ideas the participants in a positive mood generate more ideas and more creative ideas [11][12][13][14].

In order to give an adequate and efficient support to participants, the facilitator should be able to understand the emotional profile of each participant in particular. Knowing participants' emotional context, it will allow the facilitator to take actions aiming to maintain the participants in a positive mood. These actions contribute directly to the maximization of the participants' performance and, consequently, to the maximization of the idea generation meeting results.

In idea generation meetings several events may occur and affect participants' emotional profile (e.g., the introduction of new ideas, the evaluation of the ideas, the visualization and analysis of the performance). The participants may be positively or negatively affected by those events, according to the desirability they have for that event. Emotions are very volatile and they have a short duration. And in literature, what is more referred as having impact in the creative process is the mood. [15]

Besides the emotional context of the meeting, the social context is also a very important variable in modelling the group idea generation process. The elements of the group may have different personalities and different ways of reacting to events that

may occur through social interaction. Thus, we can predict that these interactions will affect the social environment in which the group is inserted. [15]

The social interaction inside a group that is generating ideas is composed by various processes: share generated ideas, exchange information/collaborative problem solving, discuss multiple viewpoints/minority dissent, engage in social comparison, manage conflict and reflexivity [15]. In the literature review on the influence of social context in group idea generation was concluded that several social factors affect the productivity in this process. The most common social factors are evaluation apprehension, free riding, production blocking and social comparison [16].

Regarding the affective context the OCC model, proposed by Ortony, Clore and Collins [17], is used to understand the emotions generated by the agents during the negotiation process (argumentation) the, for the mood is used the PAD (Pleasure, Arousal and Dominance) model and for the personality the OCEAN (Openness, Conscientiousness, Extraversion, Agreeableness, Neuroticism) model. To capture the personality of the decision maker and to model His/her agent with those features it could be asked to the decision maker to answer to The Big Inventory questionnaire, which allows obtaining values of each feature of the OCEAN model (also known as the five factors model)[18].

2. Proposed Architecture

This model has as main task supporting the decision agent in the decision making process. Taking into account the ubiquitous computing objective in supporting the user regardless of location or time, an essential task is the perception of the context in which the user is immersed. The user needs to be the main actor, independently on the context and their location.

The model also includes a constant adaptation to the user context. In addition, the model aims to anticipate the user's actions, thereby increasing the automation between the user and the environment.

The sensors are responsible for collecting all the data and to send it to the system. Thereby, the data is analyzed by certain models, which transform this information into important knowledge. Using this knowledge, the system is able to support the user in decision-making process.

The most interesting issue about an approach like this one is the capability of considering the context where we seek to take the advantage of that functionality to defend the interest of the decision maker in the decision process.

The proposed framework intends to model and support the meeting processes discussed in previous section and its main features are:

1. To support the decision making process;
2. To be endowed with intelligence which allows to assist the user in discussion that he is involved;
3. To include user's emotional state;
4. To use ontologies to represent the context and present relevant information.

In more detail, the first point pretends to allow the definition of a decision problem, evaluating alternatives and attributes; to present to the group members the results already obtained; and for the user output to present the information organized as

graphics or tables, to share the preferences of each participant by the group. The second point is the one which allows the own system to support the group decision making process, and for that it looks for solutions. This way, in this model we propose an argumentation and an idea generation supported by a contextual model. Regarding the third point, we obtain variables from the affective context. Using the information collected from points 1 to 2, we intent to use ontologies and techniques of analysis based on natural language to present information, statistics and graphics on issues related to the one that is being discussed by the decision makers.

In order to fulfill all points mentioned above we propose a two layer multi-agent framework, which can be seen in Figure 1, that includes the latest features of ubiquitous decision support systems, adaptability, context-aware and more important their reuse in other meetings context's.

For the purpose of testing and evaluation we also include two interfaces, one for meeting user's usage and other for agents high level dialog's debugging.

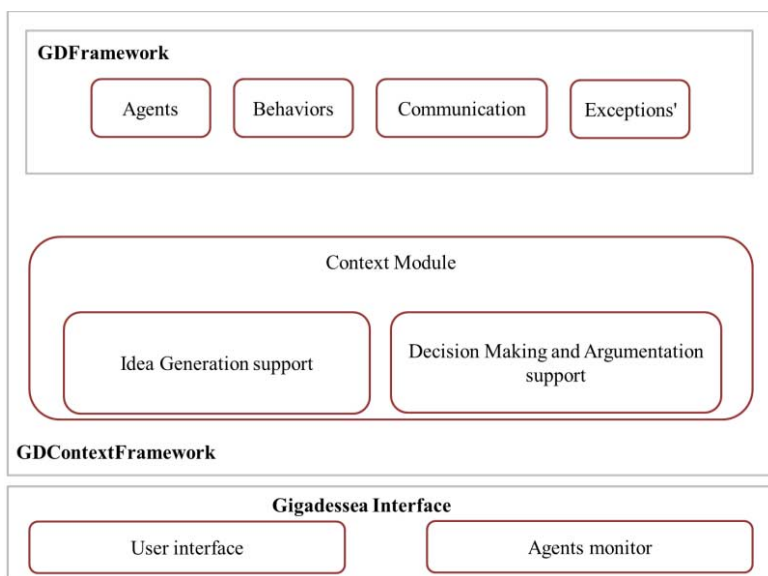

Figure 1. A Two layer architecture framework

The Gigadessea Decision Framework (GDFramework) module is used as the bridge between our proposal and Jade - Java Agent DEvelopment Framework, and it models the basic units we can in the framework. Here is defined what is an agent, the behaviors' he can have to perform his tasks and how he is able to communicate in a generic way with others. The tasks definitions are specializations of *communication* module and are performed by *behaviors* specializations included in agents. The tasks can also be used by agents behaviors' to discover other behaviors who performed by other agents, like this agents are able to delegate tasks they are not able to perform but need to perform.

In the Gigadessea Decision Context Framework (GDContextFramework) we have three big modules: the Context, Idea Generation and the Decision Making and argumentation. In the three we have agents that model the users involved in the process and agents that model the environment itself.

The context module has the task of collecting all the information about the environment in which a user is inserted. The collection of information is performed by 3 agents: a meeting agent, a knowledge indexer agent (KIA), and a knowledge inferring agent (RIA).

The meeting agent only acts in a single meeting, thereby we can have many of them, and it has two kinds of specializations which one covering different processes: the idea generation and other on the decision and argumentation process. His several tasks include the gathering of the information produced by the meeting agents, the addition of physical context information, and to request for logical contextual information on the information that he had collected. In a nutshell is able to maintain the meeting Knowledge base and to controls who can access to his meeting information. This information includes problems, ideas, decision alternatives, voting sequences, the mood and intentions of the user's. MTO and IGMTO ontologies are used to organize the physical context and to relate that information with the knowledge produced by KIA agent.

KIA and RIA agent can actually be more than one, as they perform tasks of domain ontology population and knowledge discovery. They are used for decision makers receive decisions/solutions from previous meetings that are relevant to the current decision context, by using the information on the current problem as well as the ideas and problems (and the assertions associated to it) the on demand of a user agent RIA will be able to compute a similarity measure between the current context and other contexts in the KB in order to find relevant solutions from the past and alert the user from possible solutions already proposed in the meeting. Such features can be implemented in several different ways thereby we are able to use this framework to measure the performance of such techniques because we only need to extend more *agents* that implement in a *behavior* the *tasks* performed associated to these two agents.

On *Idea generation support* and on *Decision Making and Argumentation support* modules the main idea is that we have specialization of agents that model the users' in their different decision processes and that they use the context module agents to acquire the information they need, which will be granted if the user they model have permissions for that.

On *Idea generation support* module, present in **Figure 1**, are included two types of agents who model the meeting roles available on the meeting, the facilitator and the participant. They apply a context emotional model and a facilitation model to the process support.

The *Emotional Context* represents the emotional context model of the participant. This module analyzes all emotional events produced by the context. For example, when an idea or participant is evaluated, this module will analyze if any emotion is generated. So we use emotions to infer participants' mood. Participant's mood represents the participants' emotional context over the time: if the participant is in a negative mood, then recommendations should be generated regarding the events that led the participant to that mood. The Participant Agent presented in on the left side of **Figure 2** takes into account the emotional context of the meeting where every action performed by the participant in the system will be transmitted thought this agent. In this way, it is possible to infer the participant's mood. This agent receives the events triggered in the by the participants in the meeting and generates emotions. Thus, the past emotional information is used to predict future actions, and it can help the facilitator understanding the reason for certain behaviors.

The *Facilitator model* implements a Laranjeira and his colleagues [19] proposal and has the goal of supporting the group idea generation facilitator to recommend the participants to maximize their performance. When one participant's mood is negative, the facilitator makes a recommendation based on the information generated by the model. These proposed recommendations will be based on the negative events, i.e., the events which caused the negative mood of participant. This model pretends to maximize the participants' performance, generating actions to maintain them in a positive mood. Thus, the participants will generate more ideas and more creative ideas. This module generates recommendations for supporting the meeting facilitator, in order to maximize the results of the group idea generation meeting. When a participant is in a negative mood state, analyzing the past events, this module will generate a recommendation. For example, if an idea was strongly rejected, then a recommendation can be sent to the participant to change the category of his ideas.

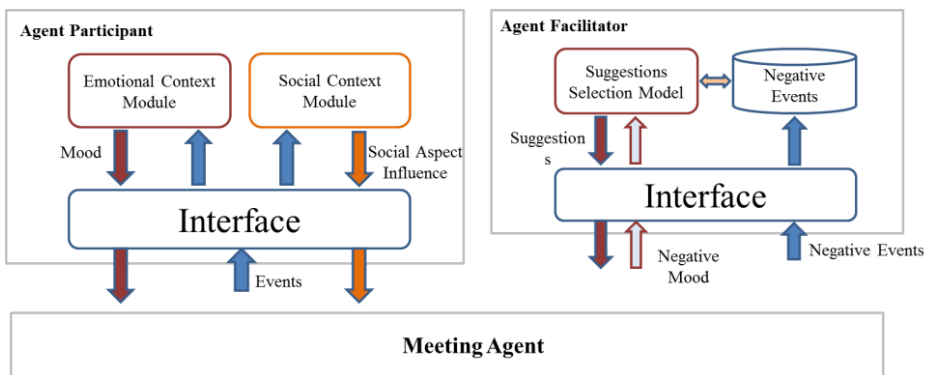

Figure 2. Facilitator and participant agent interaction between meeting agent

The facilitator and the participant agents interactions are performed through the meeting agent. The modules of each agent and their inputs can be seen in Figure 2.

Backing again to the *Decision Making and Argumentation* module seen in Figure 1 we have an agent able to support the user. Exists an agent per decision maker (or user) and in this agent are performed two kinds of supports to the user: simulation of the decision making process were the decision makers approve or request a new decision; or each decision maker receives arguments proposal that he can use in the decision making process.

In first case the Personality and Emotional modules of the agent will directly affect how the agent will simulate the decision making process. Arguments of each decision maker are also considered for the simulation. Such arguments are based in decision makers' profile. In the process of group decision-making there is always a negotiation between the various agents that represent the meeting users in order to reach a consensus. Thus, the several instances of these agents will simulate the decision process and show to their users the decision they have reach.

In second case, each agent will support each decision maker to present the best arguments based on the context of the meeting. These arguments also consider the decision maker's profile.

In both *Decision Making and Argumentation* and in *Idea Generation* modules, and regarding the affective context, the OCC model [17] is used to understand the emotions generated by the agents, for the mood part the PAD (Pleasure, Arousal and

Dominance) model [18] is used and for the personality the OCEAN (Openness, Conscientiousness, Extraversion, Agreeableness, Neuroticism) model is used. To capture the personality of the decision maker and to model His/her agent with those features it is asked to the decision maker to answer to The Big Inventory questionnaire, which allows obtaining values of each feature of the OCEAN model (also known as the five factors model).[18]

Finally, but not least, the *Gigadessea Interface* includes the support on all the interaction with agents and persons, and also includes a module that is able to debug the performed dialogs between agents on the system or only between some of them.

3. Case Study

In this section we present the scope of the tests performed to the proposed framework. We've settled a group of persons to tackle of height problems related to the domain of tourism in the city of Oporto. This group was submitted to the idea generation process in all problems and those that have been considered by the group with a satisfactory amount of promissory alternatives advanced for the decision and argumentation process. Note that the group isn't forced to do the two steps they can only do Idea Generation or if they already have the alternatives they can jump directly for de Decision and Argumentation.

From the discussion 37 ideas have emerged and were decided to advance to decision and argumentation process 5 problems.

4. Conclusion

In this paper was presented a new framework whose interface implementation enables persons to be supported in a context-aware ubiquitous group decision process. The framework presents features in order to be sensitive to context and to support the decision maker anytime and anywhere. Besides that, it takes advantages from those features, seeking to enhance the quality of the final decisions.

Our objective was to build a framework that brings considerable advantages for the decision process and that could be extended and used in other different projects that involve a decision process.

The framework presented here has the advantage of considering the logical context of the environment and also the user's mood or user's intention in the decision process. For that support are used intelligent agents. Some are used to support the context others are used to assist each participant. Those decision support agents are modeled according to the participant profile and in accordance to the decision process it is involved.

Acknowledgments

We would like to thank FCT (Portuguese Science and Technology Foundation) and FEDER, POSI, POCI and PTDC funding programs for their support in projects PEst-OE/EEI/UI0752/2011, GIGADESSEA (PTDC/EGE-GES/108524/2008) and the doctoral grant PhD fellowship SFRH/BD/38512/2007.

References

- [1] C. Ramos, G. Marreiros, R. Santos, and C. F. Freitas (2010). "Smart offices and intelligent decision rooms," in *Handbook of Ambient Intelligence and Smart Environments*, H. Nakashima, H. Aghajan, and J. C. Augusto, Eds. Springer US, pp. 851–880, 10.1007/978-0-387-93808-0 32.
- [2] C. Freitas, H. Martins, J. Barroso, C. Ramos (2011) Ontologies for meeting contents awareness – mto and igmto. In 7th International Conference on Intelligent Environments - SOOW - Smart Offices and Other Workplaces, IE '11.
- [3] J. Nunamaker, R. Briggs, D. Mittleman, D. Vogel, and P. Balthazard (1997). "Lessons from a dozen years of group support systems research: A discussion of lab and field findings". *Journal of Management Information Systems*, vol. 13, no. 3, pp. 163-207.
- [4] J. Carneiro, J. Laranjeira, G. Marreiros, C. Freitas, and R. Santos (2012). A Context-aware Model to Support Ubiquitous Group Decision Making. *Journal of Internet Services and Information Security (JISIS)*, 2(1/2), 105-118.
- [5] J. Grudin (2002). Group dynamics and ubiquitous computing. *Communications of the ACM*, Vol.45, No. 12, pp. 74-78.
- [6] M. Benerecetti, P. Bouquet, C. Ghidini (2007). On the dimensions of context dependence. In P.Bouquet, L.Sera ni, and R.H. Thomason, editors, *Perspectives on Contexts*, CSLI Lecture Notes, chapter 1, pp. 1-18. Center for the Study of Language and Information/SRI.
- [7] T. Hofer, W. Schwinger, M. Pichler, G. Leonhartsberger, J. Altmann (2003). Context-Awareness on Mobile Devices - the Hydrogen Approach, in *Proceedings of the 36th Annual Hawaii International Conference on System Sciences (HICSS'03) - Track 9 - Volume 9*. IEEE Computer Society.
- [8] G.R. Oldham, A. Cummings (1996) Employee creativity: Personal and contextual factors at work. *The Academy of Management Journal*, vol. 39, no. 3, pp. 607-634.
- [9] J.E. McGrath(1984). *Groups: Interaction and Performance*. Prentice-Hall.
- [10] C. Freitas, C. Ramos, J. Alferes (2010) ORIGAmI - ontology reuse for idea generation in AmI. In *International Symposium on Ambient Intelligence (ISAmI)*, Guimaraes, Portugal.
- [11] A. Isen, M. Johnson, E. Mertz, G. Robinson (1985). The influence of positive affect on the unusualness of word associations. *Journal of Personality and Social Psychology*. vol. 48, pp.1413–1426.
- [12] E. Hirt, G. Levine, H. McDonald, R. Melton, L. Martin (1997). The role of mood in quantitative and qualitative aspects of performance. Single or multiple mechanisms? *Journal of Experimental Social Psychology*. vol. 33, pp. 602-629
- [13] B. Frederickson (2001). The role of positive emotions in positive psychology. *American Psychologist*, vol. 56, pp. 18-226.
- [14] A. Abele-Brehm, (1992). Positive and negative mood influences on creativity: Evidence for asymmetrical effects. *Polish Psychological Bulletin*, vol. 23, pp. 203-221.
- [15] B.A. Nijstad, W. Stroebe, F.M. Lodewijkx (2002). Cognitive stimulation and interference in groups: Exposure effects in an idea generation task. *Journal of Experimental Social Psychology*. vol. 38, pp. 535-544.
- [16] H. Coskun, P.B. Paulus, V. Brown, J.J. Sherwood (2000). Cognitive stimulation and problem presentation in idea-generating groups. *Group Dynamics: Theory, Research and Practice*. vol. 4, pp. 307–329.
- [17] A. Ortony (2003). "On Making Believable Emotional Agents Believable," *Emotions in Humans and Artefacts*, R.P. Trapple, ed., MIT Press, pp. 149–211.
- [18] A. Mehrabian, "Analysis of the Big-Five Personality Factors in Terms of the PAD Temperament Model," *Australian J. Psychology*, vol. 48, no. 2, 1996, pp. 86–92.
- [19] J. Laranjeira, G. Marreiros, C. Freitas, R. Santos, J. Carneiro, and C. Ramos (2011). A proposed model to include social and emotional context in a group idea generation support system. In *IEEE Third International Conference on Social Computing (SocialCom)*.

Graphical interfaces for development exploiting the third dimension using Kinect

Raul A. Herrera-Acuña^{a,1}, Vasileios Argyriou^a and Sergio A. Velastin^b

^a*SEC, Kingston University*

London, UK

^b*Department of Informatic Engineering*

Universidad de Santiago de Chile, Chile

Abstract. The use of graphical interfaces for software development is discussed in this paper and a novel framework is proposed introducing the concept of 3D interaction during the implementation. The implications of 3D programming are explored focusing on 3D databases and their representation as long as possible uses and issues. Experiments were performed to validate the proposed system and further to indicate the importance of using three dimensions in the development systems.

Keywords. Human computer interaction, programming and developing interfaces.

Introduction

The contemporary graphical interfaces have evolved from the typical console-based writing code to visual programming environments, where the programmer can interact with the components required to create new applications, but there is still a remaining non-graphical component in the interaction. Also, those components are not advanced enough to provide the necessary flexibility and clarity to understand many aspects of the development that could be better acquired with a full graphical user interface. These problems become more obvious in pure graphic applications, which need a better understanding of the environment where the tools will actually work [1].

Research to improve interaction with computers has become one of the main issues during the last twenty years (or more) and many advances have been made. During the SIGGRAPH panel of 1998 [2], researchers addressed the importance of developing a new way to establish a communication between humans and computers. The new computer systems had to be capable to capture all the ways of communication that the human being is able to use and integrating more senses (not just vision) in interaction with software. The need of making the hardware more integrated with the work environment is necessary to improve the users' experience, making more natural the computer aided process, (e.g. in industrial design). Researchers presented approaches to break the barrier between a natural interface and a typical "device" interface.

Advances in hardware and software integration have created new ways to interact with machines. Essentially, those advances are aimed to improve human-computer interfaces and their main objective is to make these more natural, based on understanding body motion, gestures and sensory integration; and able to understand more than just

¹ R.Herrera@kingston.ac.uk.

written commands [3]. The area that is really thrusting the advances in interaction is the video game industry due to the need to provide new levels of experiences and much higher interaction between the users and the systems. Also, much of the video game innovation has been used in scientific areas (i.e. as graphic processors, interaction devices, tracking algorithms, body motion capture, etc.), both in terms of new hardware, and making that technology accessible to common people [4].

The level of detail in the interaction environment is regarded important too. Create the connection between the graphic metaphor and the data to be manipulated [5] can be problematic as well and is highly dependent of the context. In a 3D framework, the developer has to create the software layers for the specific components, including the connection graphic elements with data and the interaction language [6]. Then, the developer has to create the objects that are going to be used as basic programming elements, flexible enough to develop new applications [7].

The gesture based systems are related to hand gesture controls and they become very popular nowadays, especially in hand-held portable systems such as laptops, mobile phones and gaming devices [8]. In many cases just having a two dimensional interaction is not enough to perform naturally specific tasks, especially when these activities are performed in three dimensions in everyday life. Advances in depth capturing devices provided novel approaches to interface systems, as Microsoft Kinect has shown lately [9].

This paper presents the results of our studies on the field of 3D hand gesture interaction and how this approach can improve the developers experience and speed exploring the advantages of using a natural human computer interface. The proposed methodology solves some of the most problematic issues in this area such interaction in 3D space using finger tracking, gesture-functionality identification and recognition. Based on our analytical and empirical work the proposed framework suggests a viable alternative to conventional techniques since it provides unrevealed possibilities to design, develop, monitor, access, test and debug software, which otherwise would be very difficult to perform in a two dimensional environment.

In this paper, we propose the use of three dimensions in software development and results are presented for the case of database programming. In section 2 we briefly present some previous work on the subject of human-computer interaction.

1. Previous work

The development of new interface paradigms in the last years made apparent the need to advance the interaction approaches with information. The work of Ratti in the MIT's Tangible Media Group [10] presents an alternative to replacing the text-driven systems in geographic information systems (GIS). This new approach permits interacting with geographical data, where the user can modify the interface using tangible objects, (such as blocks, trees, hills, etc.), integrated with augmented reality environments. Furthermore, the work presents two different alternatives to implement that system: Illuminating Clay and SandScape. Illuminating Clay uses a laser based scanner to capture a physical clay model using triangulation. SandScape, instead, uses infrared illumination beneath the surface; the interaction with the surface is captured with a monochrome infrared camera and the feedback can be seen in the surface thanks to a projector above the surface. These systems were tested in a real urban design course in MIT and the results showed that this kind of systems can make the designers work easier and faster. The big problem of implementing this kind of interfaces is the high cost of the devices used and the difficulty

to configure all the hardware and software for a single application. Also, the usability tests were not performed in a real industrial environment.

The 3D representation for data is not just for simple and small systems. The possibility to represent in 3D large amount of information is explored exhaustively in the work of Markus [11], where the representation of a large software system using 3D models allows a better understanding of high dimensional data. The most relevant aspect of this system is related to the user interaction and 3D visualization, allowing visualization of different nest levels in the code. Each element represents a code segment (i.e. represented as containers) or information sources (i.e. represented as poly cylinders) mixed in a map that can be manipulated and viewed in different positions, getting even the possibility of views in 2D. The major drawback of this particular design is that the interaction is still based in 2D and that traditional devices are used keeping the disadvantages of a 2D interaction in a 3D environment. The interaction results are still limited in this model of representation and the use of more complex manipulation commands or multiple combinations of them depends on traditional interaction methods.

Another issue that should be considered is how the data will be visualized by the developer. For an environment that aims to be more natural for the user, the better option seems to present the virtual environment in 3D, allowing further manipulation corresponding to the specific scene for a given environment (metaphor). The creation of this environment is important, and the lack of tools to generate that kind of interfaces increases the difficulty. The work of Esnault in [12], addresses the problem of how future Web3D can be generated, reusing design experiences and doing a good separation between the data and its representation. The approach used by Esnault is to divide the system in two big substructures: the Genotype, a structuring metaphor construction which contains all the logical elements, such as data structure definition, the model of the exploration of the information and the access to the data source; and the Phenotype, which defines the visual aspect of the metaphor construction and the 3D visualization of the interfaces. In that case all the system is based on style sheet techniques, web-based components and an intensive use of XML. The separation presented allows strong reusability of both components in future systems. The big drawback of the proposed solution is the lack of tools to develop the 3D environment. The interface has to be created using common 2D elements in typical development systems. Also, the system proposed for the 3D environment is just for web interaction and it is not developed for natural interaction systems.

An interesting perspective was introduced by the use of modern video game devices, initially developed for entertainment, but because of their 3D detection capabilities, are used in several other applications. The most well-known cases are the infrared detection based devices, especially Microsoft Kinect. The work presented by Tang [13] related the Kinect utilization for hand gesture recognition and in [14] Frati proposed to use the same device in the field of wearable haptic technology (i.e. as a compensation for the lack of sensibility of the wearable haptic devices). This technology allows the recognition of hands and fingers for specific tasks. The only drawback of these approaches are that the tasks presented in their works, mainly are oriented to the manipulation of simple image scenarios in a graphic 3D environment, but not aiming to a higher level of interaction.

In the next section we present a novel 3D database programming environment based on 3D gesture interactions utilizing Kinect as an interface. Novel metaphors are proposed designed for 3D databases improving the development speed and the level of perception. A specific example is presented where a query is designed for a 3D database, trying to select raw and time data associated with gestures. Furthermore, the novel 3D interaction

mechanisms with the information are analyzed, presenting the initial concept, novel applications and the actual construction of these software models.

2. 3D data interaction

The contemporary graphical interfaces have evolved from the typical console-based writing code to visual environments, where the user can interact with the components required to create new applications. In the current human-computer interaction systems, there are still non-graphical elements, which could be replaced by better iconic representations of information. Also, those components are not advanced enough to provide the necessary flexibility and clarity to understand many aspects of the represented information. That could be improved and better acquired with a 3D graphical user interface. Some aspects of data could be more clear if the metaphor is included as part of the representation [15]. Additionally, some connections between 2D data representations as a 3D object could improve their understanding and functionality. Interaction with data is nowadays limited to traditional 2D environments and representations. Also, if there is a graphic representation of information, they contain just few graphic definitions (e.g. tables or data sheets), but these interface systems are not enough interactive and natural [16].

2.1. 3D Databases

The multidimensional representation of information is not a new area [17]. There have been multiple efforts associated with managing databases in more than two dimensions to improve the search/retrieve of information and data modeling [18]. These representations of the information are based on the On-Line Analytical Processing (OLAP) and the same for all the derivations to construct databases, queries and data mining. One aspect that is interesting related to 3D databases is the cube modeling and all the possible applications of that model. The possibility to represent multiple sources of information as a unique tri-dimensional entity provides the ability to manage data that could be impossible in a traditional interpretation, allowing relationship management and mapping of “hidden” information [19]. Actually all these models are managed under traditional interfaces, creating and manipulating all those models just using line commands and simple graphic representations (e.g. disconnected tables). Instead using a graphic 3D model to represent those data cubes seems to be the most natural way to interact with them. A 3D representation of those cubes will provide a better understanding of how the information in “each side” is related as a whole concept and the possibility of visually interacting with this cube (i.e. selecting rows, rotating sides and retrieving information using just gesture based interaction) will increase the productivity and efficiency in manipulating and modeling all these type of entities.

2.2. Robot Programming

Robot development and programming is a research area related to multiple fields and technologies. The main aim of robot programming is to make them perform specific tasks in the simplest way, mainly because the use of robots is not only a privilege of experts nowadays. Visual controls to manipulate specific functions of robots are popular and largely used because they provide several advantages in the manipulation of specific components and functions, such as displacement and articulation movements [20]. Even that several graphical interaction tools have been created, they still use traditional

interaction techniques with all the drawbacks associated to the limited unnatural interaction methodologies. A gesture-based programming approach can improve this task, especially in humanoid robots, where the interaction needs to be really close to the human way to react, act, and interact [21].

2.3. Development of 3D electrical systems in buildings

The modeling and development of an electric system are issues studied in [22] due to the increasing need of making them more efficient and reliable. Using 3D components that resemble the real ones, including the possibility of integrating critical structural information will provide several points of view and prevent possible risks. Also, the integration with specific devices, like climate control systems, in a 3D environment can also speed up the construction of new buildings [23]. A gesture based system could certainly improve the collaborative and interdisciplinary work, highly necessary in the construction and planning of electrical systems for large edifications.

3. Proposed Methodology

The proposed methodology attempts to define a novel way to create a common structure for different kinds of 3D hand gesture based applications. This methodology comes from our previous work to define a common developing framework for two handed gesture interaction in 3D environments [16]. In this approach, the application is divided in several layers, each of them with specific tasks. The layer architecture and the connection between their components can be seen in Figure 1.

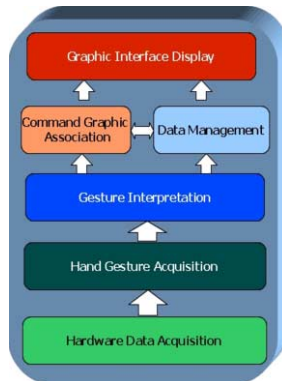

Figure 1. Layer architecture for two-handed gesture based systems.

The base layer of the proposed systems is related with the data acquisition and the hardware needed to perform this task. In this layer, all the APIs and drivers are placed. For our study case, we use Microsoft Kinect because of the features that provide in the human posture/movement detection. The depth detection is crucial in order to perform 3D activities, necessary for natural 3D interaction. The next layer is related to the identification of the hand gesture, which in our case is related to the hand and fingers identification. The gesture interpretation is the layer responsible to “translate” the gesture into a specific command, strictly related to the interaction environment. Command graphic association and data management take control of the actions and the state change of the environment. Performing a gesture triggers a subsequent action and the graphic

interface display shows the result of the interaction. This architecture provides the flexibility to define several kinds of applications based on 3D interaction. Also, it can provide a high degree of hardware independence.

Considering this architecture, there are some specific issues we should consider in our experiments, based on 3D interaction databases. These aspects are discussed below:

3.1. Finger tracking

This aspect is relevant to a hand-gesture based interaction, because our system gestures are based on the hand and finger correlation and their differences. The detection of the hand is based on the depth map proportioned by Kinect® device, under the usage of OpenNI ® drivers and SDK to connect the device to a normal computer and the possibility of gather data directly from the device and get some specific information (such as palm hands position) . The interactive environment was programmed in C# using WPF for the graphic design and 3D modeling; all developed using Microsoft Visual Studio 2010. The detection of the hand's contour relies on the segmenting the depth map at specific distance. In order to identify each hand, the relative position in the detection space is considered. The system uses an approach similar to the one presented by Frati [24] to perform the detection of the fingers. Each finger is detected by identifying the end points and their convexity. Each end point represents a finger, but also, the palm location provides information about the relative 3D position of each finger in the hand. However, since the detection of the hand is provided by segmentation, it lacks the problems of the hand gesture/detections of the work presented by Tang [13]. In that work the detection of each hand depends on the distance from the sensor (infrared), on occlusions and possible reflection problems. Also, the hands are detected as independent elements, not connected with the whole body, which limits the range of detection, but provides more degrees of freedom and gesture recognition speed. Experimentally, the optimal distance between the user and the Kinect® device should be approximately between 60 and 90 centimeters for and optimal hand and finger detection and ideally, the movements should be performed in parallel to the device.

3.2. The interaction

The interaction in our model is based only on “pure” hand-gestures, which means the interface is using the hand and no other “device” is involved to perform the tasks. This hand-gesture interaction is based on the number/position of the fingers and their changes will generate different actions and constantly different responses by the system. For our basic model, one hand indicates the function or mode and the other hand will perform the action itself. Considering that, the interactions will be divided in three groups:

- **Movements:** These actions correspond to changes in the position and/or orientation of 3D graphic elements in the environment.
- **Selections:** The selections are related to choosing or highlighting specific 3D elements or components and parts of them.
- **Executions:** Interaction related with triggering an action could be the result of a combination of the previous ones or a new separate hand gesture.

3.3. 3D Databases

3D databases are a derivation of multidimensional databases as explained previously. In our case, we consider the cube database. These kinds of databases provide an interesting

field of research development due to the several data mining features offered by this model [3]. This kinds of databases are useful in cases where the relationship between different pieces of data are not totally clear and it is necessary to connect several information sources, which cannot be performed by traditional 2D databases. A clear example of that is related to medical information, where the need to find association between factors not obviously related could help to improve the patient attention and diagnosis. In that example, hidden health factors and possible causes of diseases and sickness could be shown. However, because of the complexity of the traditional model, we defined a novel one that resembles the functionality, but with a simplified approach, where the cube is formed by multiple tables related between them.

4. Experiments and Results

In order to evaluate and test the proposed methodology experiments using a simplified version of a 3D cube database was performed. A hand-gesture interactive system was developed to compare this approach of writing specific queries with a traditional SQL set of sentences. The relevant elements of this experiment are explained below:

4.1. The interface

The experimental interface to test our proposed methodology was a 3D data interaction model. A simplified model of a cube database with the two faces of the cube representing information about a group of patients was developed. The test interface model can be seen in Figure 2.

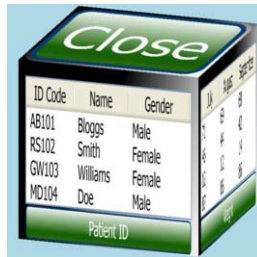

Figure 2. Data Cube model.

One of the faces contains basic identification information of the patients. The other face has information about their weight over time. The top face of the cube gives the possibility to close the application. The rest of the faces of the cube contain the same close button than the top face. This simplification was applied to avoid confusing the users of 3D interfaces and test a limited interaction. Additionally in this particular example of 3D databases only two sides of a cube are required to fully describe the relationships, but more complex datasets could be represented using either more faces or other models.

The user is able to interact with this cube using both hands. The left hand is used as function indicator and the right hand performs the action on the screen. This configuration was decided to limit possible confusions between actions. The “indicator” finger is depicted by the cursor, indicating the exact position on the screen and the cube. Any other combination of hand/fingers will not produce any result in the interface.

There are 3 types of interactions:

- I Rotation: The cube can be rotated from left to right and vice versa. In order to make the interface more intuitive only two faces of the cube are accessible, the

front face (with the patients' personal information) and the right side (with the weight/month information). This action is performed by keeping the left hand open and the movement action is performed by moving one finger of the right hand from left to right or vice versa, depending on the face that the user wants to see. There is no rotation on the horizontal axis.

- Selection: Users must display two fingers of their left hand and placing the moving finger over an element to select it.
- Clicking: The user must remain in selection mode (two fingers of the left hand) to access this mode. In order to perform the clicking, the indicator finger must be placed over a selectable element and “push” (move forward, towards the screen).

In our implementation the selectable elements of the cube are the button “close”, the column headers and the rows. To select a full column, it is just necessary to click on the column header.

Each of these movements has thresholds to avoid considering as actions random movements. Also, the full interface have indicators to facilitate each task, such as the “function mode” indicator which shows the function mode, the action performed and the column (if it is necessary) where the action is being performed.

4.2. The Experiment

In our experiment the simulation of a simple information selection from two tables is performed. In this specific case, the user is asked to select the name and the weight information during July and August. There is no specific order in the selection, but the combination of these three columns is needed for each face of the cube. This aspect eliminates the possibility of “random” performance of the task.

The general idea is to show the user the possibility of a graphical query over a traditional SQL query and obtain information about the advantages and disadvantages related to the performance of that process. Also, qualitative information over the usability of the interface and the general user satisfaction is obtained. The idea to compare a cube 3D interface with an SQL query resides in the general concept of data manipulation, access and retrieval over a 3D environment that traditionally has been under 2D domains. Also, the cube interface configuration suits with a 3D hand-gesture based interface, because an interface of this type resembles aspects of the real world.

To improve the human computer interaction feedback according to the proposed task was provided. The full interface for the experiment can be seen in Figure 3.

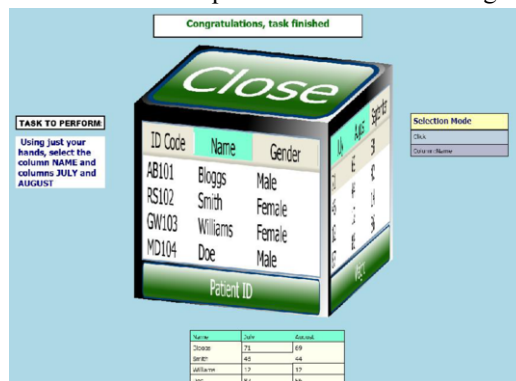

Figure 3. Full Interface.

4.3. Procedure of the experiment

The experiment was divided into six steps, presented below.

- **Details and objectives:** The objective of this experiment is to gather information about the possibility of using a hand gesture interface instead of the traditional SQL code to perform queries on a 3D database.
- **Demonstration:** The aim of this section is to present to the users the interface and its elements, answering any related questions. Also, if the user is not familiar with SQL, the basics of the language will be explained.
- **Familiarize the subject with the interface:** During the familiarization stage with the interface, interaction with the interface will be presented allowing the user to practice.
- **Subject performs the available functionalities:** The available functions (e.g. rotate, click) will be explained and performed by the user.
- **Perform the full task:** Once the user familiarize himself with the environment and with how to perform the available functions, then the full task will be performed counting the required time to accomplish it.
- **Complete the questionnaire:** After the completion of the task, a questionnaire about this experience is provided, evaluating and comparing the available interfaces (i.e. visual and SQL).

The sequence of interaction can be seen in figure 4.

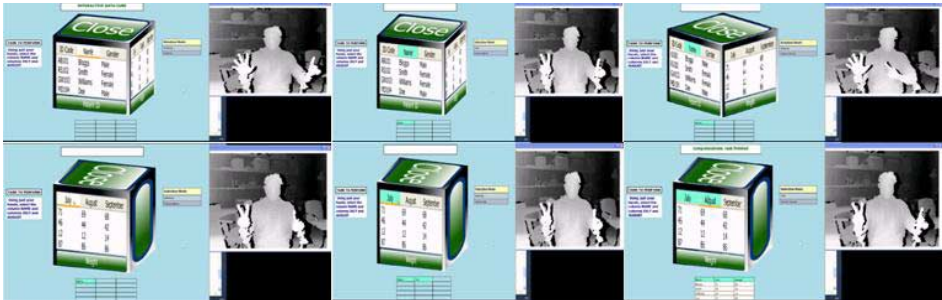

Figure 4. Experiment interaction sequence

4.4. Questionnaire Analysis

The result of the experiment is directly evaluated by the summarized information collected by the questionnaire. The construction was based on the usability model presented by Lewis [24] and the questions been divided into 3 sections, with a range from 1 (extremely bad) to 5 (extremely good). Twenty students and professionals in the computer science field participated, and further details were collected such as the age, the time to perform the task, gender and knowledge of SQL or not. The sections of the questionnaire are described in table 1.

Table 1. Questions by section from usability questionnaire

Section 1	Section 2 - How would you rate:	Section 3- SQL interface compared with the proposed visual approach
Was the interaction easy to understand?	The Interface?	The selection is easier than SQL?
Was it easy to manipulate ?	The Performance?	The task is more intuitive than SQL sentences?
Is the navigation system intuitive?	The functionality?	Is it easier to learn the proposed visual approach than SQL?
	The objective achieved?	Is the task faster to perform than with SQL?
	The user experience?	
	The hand gestures selected?	

4.5. Obtained Results

The results are presented below and the significant points are related to the “external” information, the questions, the performance time and the correlation between them.

Table 2. Average results and deviation values by section

<u>SECTION</u>	<u>Q1</u>	<u>Q2</u>	<u>Q3</u>		
Average	4.5	3.2	3.9		
Deviation	0.69	0.62	0.81		
<u>SECTION</u>	<u>Q4</u>	<u>Q5</u>	<u>Q6</u>	<u>Q7</u>	<u>Q8</u>
Average	4.0	3.4	3.8	4.2	3.8
Deviation	0.73	0.75	0.72	0.7	0.91
<u>SECTION</u>	Q9	Q10	Q11	Q12	Q13
Average	3.9	4.0	4.3	3.4	3.9
Deviation	0.93	0.79	0.72	1.27	0.93

In the tables 2 to 4 the obtained average scores for the answered questionnaires are showed. As it can be seen, for the first section, the main positive point for the user is related with how easy is to understand the interaction. Also, the interface obtained the higher points along with the possibility to achieve the task properly. In comparison with SQL, the system presents really strong points in the intuitive use and the learning simplicity. Also, it is relevant that any answer had an average punctuation not lower than 3 (normal).

The time performance is another important parameter to analyze. Some graphics presented below showing how different aspects are related to the speed and the time to accomplish the tasks.

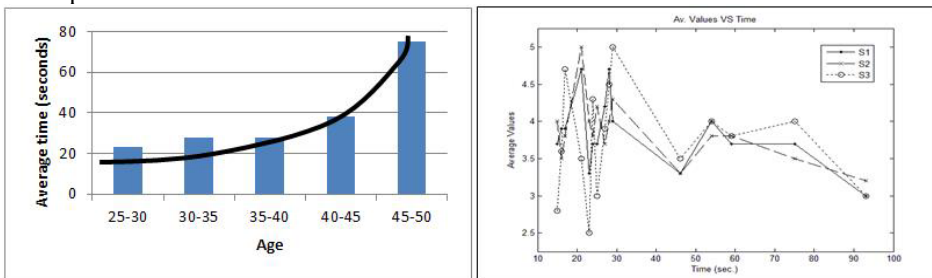

Figure 5. Performance of the subjects according their age & scores per section VS performance time

The age of the users seems to be a factor related to the required time for using this interface, because, as can be seen, people younger than 40 years old resulted the best times. This is especially clear with the subjects below 30s, as it can be seen from the curve that better interaction times were obtained in general compared with the elder people. The performance difference is more pronounced as we move to subjects about 40s following an exponential function.

The satisfaction level seems not to be an important point in relation to the time required to perform the actions. The following graphs demonstrate this observation.

The performance does not vary significantly relative to the preference for the interface, but in the three sections, the people that were more satisfied seems to be also faster.

Finally, the gender and the knowing of SQL show some interesting results.

Table 3. Average time and age for males (75% of the subjects), females (25% of the subjects), people who knew sql (70% of the subjects) and people who did not know (30% of the subjects)

	<u>Male</u>	<u>Female</u>	<u>SQL</u>	<u>No SQL</u>
Av. Time	33.47	30.2	33.57	30.5
Av. Age	36.07	31	33.57	36.33

The difference in performance time seems to be minimal, but it is observed that females and people that declares not knowing SQL seem to be fastest than males and people who knows SQL. From the obtained results it is shown that the knowledge of SQL is not an advantage in the manipulation and interaction with 3D environments. This is also part of the aims of this novel programming approach that tried to make the system easy to use without having requiring any programming knowledge of SQL or being an advantage.

5. Conclusions

In this work a novel 3D based interface for software development was proposed. A set of interaction methodologies was analyzed and discussed indicating that some applications require the third dimension to exploit all the available interaction techniques.

In order to evaluate and validate the proposed system qualitative experiments were performed focused on 3D database design and development. The system was developed using Kinect and capturing the fingers of the user. From the obtained results it can be observed that using a 3D representation for that kind of applications can significantly improve the user experience and improve the development speed. Also, this approach seems represent better the representation and interconnection of data elements, allowing a better understanding of the information.

Future work on this area will be focused in improve some aspects of interaction and selection of data process in the 3D interface presented. Different interaction approaches will be tested and evaluated trying to improve the HCI. Also, other modalities will be used to support more complex tasks such as advanced commands related to database programming or other development areas.

References

- [1] M. Rotard, D. Weiskopf and T. Ertl, "A combined introductory course on human-computer interaction and computer graphics", *Computers & Graphics* 29(2005), 267-272.

- [2] M. Harris, B. Buxton, W.T. Freeman, H. Ishii, M. Lucente and M.J. Sinclair, "Interfaces for humans (panel): natural interaction, tangible data, and beyond", SIGGRAPH 98 Conference abstracts and applications, 1998, 200-202.
- [3] A.F. Blackwell., "Dealing with new cognitive dimensions" in *Workshop on Cognitive Dimensions: Strengthening the Cognitive Dimensions Research Community.*, University of Hertfordshire, 2000.
- [4] P. Barr, J. Noble and R. Biddle, "'Video game values: Human-computer interaction and games" *Interactive Computers* **19-2**(2007) , 180-195.
- [5] M. Wu and R. Balakrishnan, "Multi-finger and whole hand gestural interaction techniques for multi-user tabletop displays" *ACM Special Interest Group on Computer Graphics and Interactive Techniques* (2003), 193-202.
- [6] K.P. Fishkin, "A taxonomy for and analysis of tangible interfaces", *Personal and Ubiquitous Computing*, **8-55**(2004), 347-358.
- [7] M. Conway, S. Audia, T. Burnette, D. Cosgrove and K. Christiansen, "Alice: lessons learned from building a 3D system for novices" *Proceedings of the SIGCHI conference on Human factors in computing systems* (2000), 486-493.
- [8] Y. Boussemart, F. Rioux, F. Rudzicz, M. Wozniowski and J.R. Cooperstock, "A framework for 3D visualisation and manipulation in an immersive space using an untethered bimanual gestural interface", *Proceedings of the ACM symposium on Virtual reality software and technology*(2004), 162-165.
- [9] E. Guettard, S. Jandziak , C. Lombard , N. Podevin , V. Varane , P. Dumont , "Virtual reality from the keyboard/mouse couple to Kinect", *Annals of Physical and Rehabilitation Medicine*, **54**(2011), pp. 239.
- [10] C. Ratti, Y. Wang, H. Ishii, B. Piper and D. Frenchman, "Tangible User Interfaces (TUIs): a novel paradigm for GIS", 2004, vol. 8, no. 4, pp. 407-421. 2004, vol. 8, no. 4, pp. 407-421. *Transactions in GIS*, 2004, vol. 8, no. 4, pp. 407-421.
- [11] MARCUS, A., FENG, L. AND MALETIC, J.I " 3D representations for software visualization" *In Proceedings of the 2003 ACM symposium on Software visualization*, 27-ff.
- [12] N. Esnault, J. Royan, R. Cozot and C. Bouville, "A flexible framework to personalize 3D web users experience", *Proceedings of the 15th International Conference on Web 3D Technology*,(2010), 35-44.
- [13] M. Tang, "Recognizing hand gestures with microsoft's kinect," Web Site: http://www.stanford.edu/class/ee368/Project_11/Reports/Tang_Hand_Gesture_Recognition.pdf, 2011.
- [14] V. Frati and D. Prattichizzo, "Using Kinect for hand tracking and rendering in wearable haptics", *IEEE World Haptics Conference* (2011), 317-321.
- [15] L. Chittaro, R. Ranon and L. Ieronutti, "3D object arrangement for novice users: the effectiveness of combining a first-person and a map view", *Proceedings of the 16th ACM Symposium on Virtual Reality Software and Technology* (2009), . 171-178.
- [16] R.A.H. Acuna, C. Fidas, V. Argyriou and S.A. Velastin, "Toward a Two-Handed Gesture-Based Visual 3D Interactive Object-Oriented Environment for Software Development," *Proceedings of the 8th International Conference on Intelligent Environments* (2012), 359-362.
- [17] K. Stefanidis, G. Koutrika and E. Pitoura, "A survey on representation, composition and application of preferences in database systems", *ACM Trans.Database Syst*, 36-4(2001).
- [18] R. Agrawal, A. Gupta and S. Sarawagi, "Modeling multidimensional databases", *Proceedings of 13th. Int. Conf. On Data Engineering (ICDE)*(1997),. 232-243.
- [19] P. Vassiliadis, "Modeling multidimensional databases, cubes and cube operations", *Proceedings of the 10th International Conference on Scientific and Statistical Database Management* (1998), 53-62.
- [20] P.I. Corke, "Visual control of robot manipulators-a review," *Visual servoing* 7 (1994), 1-31.
- [21] T. Kanda, H. Ishiguro, T. Ono, M. Imai and R. Nakatsu, "Development and evaluation of an interactive humanoid robot" *IEEE Proceedings* **2**, 1848-1855
- [22] W.H. Kersting, "Distribution system modeling and analysis", (2012).
- [23] F. Oldewurtel, D. Gyalistras, M. Gwerder, C.N. Jones, A. Parisio, V. Stauch, B. Lehmann and M. Morari, "Increasing energy efficiency in building climate control using weather forecasts and model predictive control" *RHEVA World Congress* (2010) , 9-12.
- [24] J.R. Lewis, "IBM computer usability satisfaction questionnaires: psychometric evaluation and instructions for use", *International Journal of Human - Computer Interaction* **7-1**(1993), 57-78.

Visual Multi-Agent Argumentation Solver

Nuno LOPES^{a,1}, Ricardo SANTOS^{a,b} and Goretí MERREIROS^{b,c}

^a*CIICESI, Escola Superior de Tecnologia e Gestão de Felgueiras, Instituto Politécnico do Porto, Portugal*

^b*GECAD – Knowledge Engineering and Decision Support Group*

^c*Institute of Engineering – Polytechnic of Porto, Portugal*

Abstract. Argumentation has become a very important subject in computer science research. Its importance has been increased over the years in the topic of Multi-Agent Systems because it offers the tools to implement sophisticated systems that allow the interactions between intelligent agents. In this paper we propose a Multi-Agent system that will work in an intelligent environment, in which the agents have the capacity to argue with which other, with the goal to reach a group decision, using Dung's argumentation framework as a base.

Keywords. Argumentation, Multi-Agent Systems, Abstract Argumentation, Intelligent Environment, Decision Making

Introduction

In a Multi-Agent environment, when agents try to pursue their goals, argumentation is the key. We present argumentation as a tool, with which the agents can negotiate, persuade and exchange proposals in order to achieve their individual goals[1], [2][3].

In this paper we propose a Multi-Agent argumentation solver, which model will be depicted as a system having two main components: (1) the front-end which will be responsible for the interaction with the user, and (2) the back-end which will be responsible for the negotiation process between agents.

In our work we want to integrate our Multi-Agent System in an intelligent environment, with the goal to facilitate the dynamic between the agents, so they are able to reach a group decision that satisfies the agents involved. In order to construct the agents' argumentation capabilities we will use Dung's framework[4].

In this paper we will present the architecture of our work and explain how that will work. We will also present an example of software product that gives us the idea to create a Multi-Agent Argumentation solver, called WizArg[5].

Having this in mind, we start by making a brief review of the concepts of Multi-Agent Systems, Intelligent Environment, Group Decision Making and Dung's framework, following by the presentation of our idea. As a conclusion we will show you some hints about how our work will proceed.

¹ Corresponding Author: Escola Superior de Tecnologia e Gestão de Felgueiras, Instituto Politécnico do Porto, Apt. 205, 4610-156, Felgueiras, Portugal; Email: 8060152@estgf.ipp.pt

1. Dung's Argumentation Framework

The abstract argument system or argumentation framework is a pair $AF = (AR, B)$, where AR is a set of arguments and B is a binary relation on AR called attack relation [4]. It's essentially a directed graph in which the arguments are the nodes and the arrows the attack relation. We can say that A attacks B if $AF = (A, B)$ holds. Equally we can say that a set S of arguments attack B if B is attacked by an argument in S .

As we can see above in the definition of argumentation framework different arguments can attack each other. At each attack between arguments, some arguments are able to attack successfully other arguments, while others are not able to do so, thus, intuitively we can say that if an attack of (A, B) holds, we can conclude that the argument A is acceptable while the other argument not. To address these evaluation processes of arguments we have argumentation semantics which are divided in two main groups: extension-based semantics and labeling-based semantics [6].

1.1. Extension-Based Semantics

We will now review several argumentation semantics proposed in the literature, but for the introductory purpose of this paper we will limit these to the four originally considered by Dung, namely: complete, grounded, stable and preferred semantics [4]. In common to these semantics we have this definition [4]:

- We have a conflict-free set of arguments if there is no arguments A, B in such that A attacks B .
- We can say that an argument A is acceptable with respect to a set S if S can defend A by an argument $B \in S$ against all attacks C on A .

1.1.1. Complete Semantics

The concept of complete extension is based on the principle of admissibility and reinstatement, in other words, is a set that is able to defend itself and includes all arguments it defends. Intuitively, the notion of complete extensions captures the kind of confident rational agents who believes in everything he can defend as stated by the following definition:

- An admissible set S is called complete extension if each argument which is acceptable, with respect to S , belong to S [4].

1.1.2. Grounded Semantics

This semantics give us the most skeptical semantic among all others. The idea is to accept only the arguments that we are obliged to accept and reject the arguments we are obliged to reject. In summary we refrain as much as possible. The formal definition is listed below:

- The grounded extension of an argumentation framework AF , denoted $GEAF$, is the least fixed point of its characteristic function F_{AF} [4].

1.1.3. Stable Semantics

This semantic is very simple to perceive. It states that an argument attacks another if this does not belong to the same set as we can see by the following definition:

- A conflict-free set of arguments S is called stable extension if and only if S attacks each argument which does not belong to S [4].

1.1.4. Preferred Semantics

This semantic is the opposite of the grounded semantic. The goal is to maximize the accepted arguments in order to be as large as possible, so that it defends itself from attacks. The respective definition is listed below:

- A preferred extension of an argumentation framework AF is a maximal (with respect to set inclusion) admissible set of AF [4].

2. Argumentation in Multi-Agent

The Multi-Agent System (MAS) is a software system composed by various intelligent agents which interact with each other with a common goal, within a specific environment. The MAS had its origin in the distributed Artificial Intelligence with the aim to solve problems that are difficult for a single agent to solve [7] [7][8].

Agents that work inside the multi-agent environment need to associate with others agent in order to gather information or to use services [9]

Negotiation has been in the center stage in the development of MAS [10] with a goal to resolve conflicts between agents with differing interests [8][10]. In our opinion, if we integrate these MAS in an intelligent environment we believe that will make the negotiation process more effortless.

3. Intelligent Environment

The notion of Intelligent Environment has largely arisen through the energies of the European Commission. It relies on the areas of ubiquitous computing, ubiquitous communications and intelligent user interfaces. The idea describes an environment of many embedded and mobile devices interacting to support the tasks of the users [3].

These characteristics seat very well with our work because we want that our agents be able to interact with other agents in the environment in order to achieve their goals. These types of interactions allow us to better simulate a group of people trying to reach some decision in a collaborative way.

4. Group Decision Making and Negotiation

Group decision making and negotiation embody very complex human activities.

These terms often appear in the same context because group decision making involves discussion and argumentation between the participants in order to reach a decision [11].

The benefits of the group decisions are vast:

- Groups are better than individuals at understanding a problem and find the better solution;
- People are more responsible for the decision in which they participate;
- A group has more knowledge than only one member.

Group decision, although believed to be the better way to reach a solution, many times leads to conflicts and disagreements. To resolve these, negotiation is the best technique. The ability to argument, justify and persuade the other participants of the group about some specific issue is really interesting. This concept falls within our work.

5. Wizarg

One example of an abstract argumentation solver is the project WizArg [5]. The project was a major step to close the gap between theoretical argumentation results and extension-based argumentation systems.

WizArg can be divided in two parts: (1) the back-office that has the objective to deliver a library that allows generic computational processes to use argumentation metainterpreters and (2) the front-end that provide users with ability to create their own argumentation framework and visualize the results of the argumentation.

While very promising, WizArg has some limitations such as:

- The current version does not work in multi-agent platform.
- The current version does not automatically know how to determine which semantics to use. We have to choose it at priori.

The WizArg is still in development and its application area described as an example of a prototype for abstract argumentation solver [12]. However, the idea behind the WizArg approach tells us that its application can be used for any argumentation framework solver. The idea that we can visualize the creation of our argumentation framework and their result is really interesting. Having this idea as base, we pretend to add concepts like multi-agent systems, intelligent environments and group decision making techniques to our work.

6. Visual Multi-Agent Argumentation Solver

In this work we propose a multi-agent argumentation solver that work in an intelligent environment having as goal to reach a group decision. Our aim is to create a simulation of a group of people that negotiate with each other, with the finality to reach a solution.

Our model will be depicted in a system with two main components: the front-end and the back-end. The front-end will be responsible for the interaction with a user. This component will allows us add, edit and delete agents and arguments in a user-friendly way. The arguments and the attack relation will appear to the user in a graph form, where the nodes are the arguments and the edges are the attack relation. When the agents negotiate, the front-end will paint the nodes following a labeling approach, applying one the following colors to each node [13]:

- Red if the argument represented by a node is defeated.
- Green if the argument represented by a node is accepted.
- Grey if the argument represented by a node is undecided.

The back-end will be responsible for the negotiation between agents. When an agent receives an argument, it will make a search in the knowledge base, and verify if the argument is acceptable or not. It is possible for the agent to consult other agents to verify the received information and update his knowledge base. We assume that the information that the agent possess is not always complete or accurate. We intent that with each interaction, with each negotiation, the agent will improve his knowledge base and his arguments for future interactions as in real life negotiations (this new information may come in form of fresh data about the issue in discussion or the observation of the actions of the other agents). This process continues until the group of agents reaches a solution adequate to their goals.

To simulate the participants we will create an agent with the ability to interact with other agents and with the environment. The agent architecture will be constituted by three layers: *Knowledge*, *Reasoning* and *Interaction* [3], [7], [12].

The Knowledge layer will have three subsystems:

- Self-Model
 - It will be responsible for the agent's profile, in which we can find his identity, attributes and goals.
- World Knowledge
 - It will be responsible for the agent information about the subject in question and the environment. This subsystem will be frequently updated with each negotiation.
- Model of the Others
 - It will have a database of profiles and history of the past negotiations with the opponent's agents.

The Reasoning layer will have two subsystems:

- Argumentation System
 - It will be responsible for the arguments generation. It will have access to the Knowledge Layer to help the generation of arguments and its validation.
- Decision Making
 - It will help the agents choosing the preferred alternative.

The Interaction Layer will also have two subsystems:

- Communication
 - It will be in charge of the communication with the other agents and will redirect the message received for the right layer. The knowledge that the agent acquires with the interaction with other agents and environment are obtained in this subsystem.

- Interface
 - o This subsystem will be responsible for the interaction with the user. The user will be able to create, edit and delete agents and arguments in a user-friendly way.

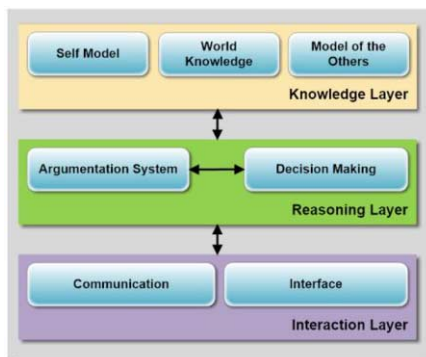

Figure 1. Agent participant architecture

7. Argumentation System

The Reason Layer will be the focus of our work, specially the Argumentation System. We will use Kraus work in respect of the type of the arguments that he identified [16][3] and we will use Dung’s argumentation framework to make the agents reasoning about their requests [4].

In our Argumentation System we will have three types of messages between the agents: *request*, *accept* and *reject*. The *request* will be a type of message with the goal to ask assistance or whatever the agent needs from another agent, while the *accept* or *reject* type are simply messages with the aim to inform the other agent that its request is acceptable or not. Each agent will need to have a set of pre-defined requests that may help him interact in the future. Inside of each type of message will exist a set of arguments that the agent will use to justify or persuade the opponent about his requests or responses. Each argument will have a type. These types of arguments will be the six types that Kraus identified [16][3].

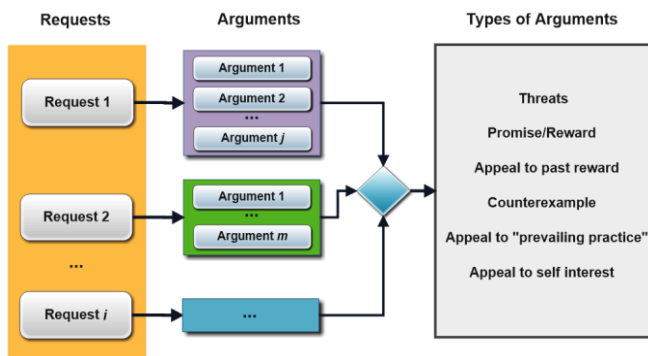

Figure 2. Types of messages exchanged between agents

To better understand the interaction between agents, we will use an example used by Kraus [16].

As we can see in Figure 3, we have two robots that engage in a negotiation. The robot *Re* has a better camera to help identify more quickly the minerals that he is supposed to mine, while the robot *Rh* has better hands which allow him to mine more quickly.

The *Rh* senses that he needs help to do his job more quickly, so, he searches in his set of requests for one appropriate for his problem. After finding one, he sends a request to *Re* to help him identify more quickly where the minerals are. But *Re* rejects his request justifying that he will waste plenty of time helping him. Then *Rh* sends a new request with an argument/threat saying that if *Re* does not help him he will destroy his camera. This time *Re* does not reject because the last argument may affect his work, so, he sends a new request with an argument/promise/ reward, saying that if *Rh* helps him now, he will help him after his job is done. The *Rh* accepts the terms of the negotiation. Both robots will save the negotiation data in the Knowledge Layer.

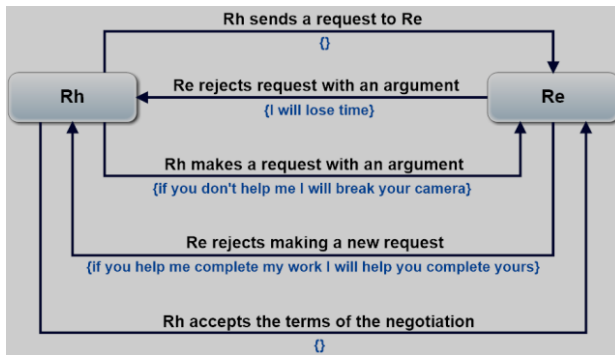

Figure 3. *Re* and *Rh* interactions

To measure the acceptability of the arguments between these two robots we will use Dung's Argumentation Framework to decide if an argument can be accepted or not. Dung defined several semantics of acceptance as we can see above in this paper [4].

The robots can use different mechanisms to infer the information:

- Credulous inference
 - o The robot will risk accepting some arguments which are not acceptable.
- Skeptical inference
 - o The robot will risk deducing little information.

Following the example with the two robots we will see the Dung's Framework in action after the robot *Rh* sends a request to *Re* to help him doing his job.

This is the list of arguments use by both robots:

- A → *If you don't help me, I will break your camera.*
- B → *I have to do my own work.*
- C → *I have to be 100% operational, in order to my job.*
- D → *It's important to cooperate.*
- E → *I help you if you have to help me finish my job.*

F → *I don't have time to help you.*

G → *I have a good camera, which allows me to find new dig sites.*

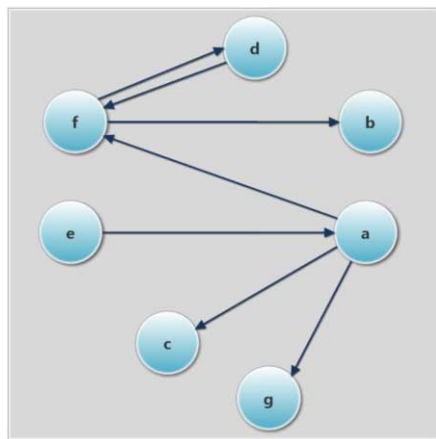

Figure 4. Interactions between agents

As we can see in the image above, during the negotiation, if the agent *Rh* is a credulous robot he will accept the set of arguments $\{C,E\}$, $\{E,G\}$ and $\{E,D\}$ sent by *Re*. If he is a skeptical agent, he will accept the argument $\{E\}$.

8. Conclusion

This article has as goal to complement Kraus's argumentation work [7] [14].

We presented the idea of our Visual Multi-Agent Argumentation Solver, starting by making a brief revision of the concepts we intent to implement.

The aim of our work is to give a problem to a group of agents, which will have to interact with each other to get as much information as possible, to make better arguments in order to reach quickly to better decision. The goal is with each interaction and negotiation the agents that participant gather new knowledge about the discussion issue and information about the opponents, using it in future negotiations.

The software that we intend to develop still is in embryonic stage and the architecture has is much space for improving like:

- To better simulate a group decision meeting we need to introduce other agents than the existing participants:
 - *Facilitator Agent*: guides the meeting, controlling who can speak, ensuring that negotiation not be dragged to long.
 - *Information Agent*: has the basic information about the subject of the meeting and the rules of negotiation. This information will be available to every agent participating in the negotiation.
- The introduction of a voting system to help the agents reach a solution more quickly.

- We believe that to better help the agents evaluate the arguments and its types, the original Dung's Argumentation Framework is not enough, because some arguments are more stronger than others during a negotiation. We will research the a idea of Value-Based argumentation framework [17].
- To improve our agents adaptation over repeated negotiations, more precisely about new arguments and its consequences for the agent. We feel that we need to do more research [18].

We believe that a Multi-Agent system that works in an Intelligent Environment with a goal to provide the agents to reach a group decision is the better way to simulate what happens in negotiation in real life.

References

- [1] N. Jennings, S. Parsons, P. Norrie, and C. Sierra, "On augmentation-based negotiation," *Autonomous Agents and Multi-Agent Systems*, pp. 1–8, 1998.
- [2] J. Votano, M. Parham, and L. Hall, *Argumentation in Artificial Intelligence*. 2004.
- [3] G. Marreiros, C. Ramos, J. Machado, and J. Neves, "Argument-based decision making in ambient intelligence environments," *International Journal of Reasoning-based Intelligent Systems*, vol. 1, no. 3/4, p. 182, 2009.
- [4] P. M. Dung, "On the acceptability role in nonmonotonic of arguments and its fundamental reasoning , logic programming and," *Artificial Intelligence*, vol. 77, pp. 321–357, 1995.
- [5] I. Gómez-Sebastià and J. Nieves, "WizArg: Visual Argumentation Framework Solving Wizard," *In Proceedings of CCIA'2010*, 2010.
- [6] I. Rahwan and G. R. Simari, *Argumentation in artificial intelligence*. London: Springer, 2004.
- [7] R. Santos, G. Marreiros, C. Ramos, J. Neves, and J. Bulas-Cruz, "Personality, Emotion and Mood in Agent-based Group Decision Making," *IEEE Intelligent Systems*, vol. 26, no. 6, pp. 58–66, 2011.
- [8] S. Kraus, "Negotiation and cooperation in multi-agent environments," *Artificial Intelligence*, 1997.
- [9] R. Stacey and M. Colley, "Agent association group negotiation within intelligent environments," *Intelligent Environments, 2008 IET 4th International Conference on*, pp. 1–6, 2008.
- [10] S. Kraus, "Automated negotiation and decision making in multiagent environments," *Lecture notes in computer science*, vol. 104, pp. 150–172, 2001.
- [11] J. Neves, P. Novais, J. Machado, G. Marreiros, and C. Ramos, "An agent-based approach to group decision simulation using argumentation," pp. 263–270, 2006.
- [12] M. Osorio, J. N. Sánchez, and I. G. Sebastià, "CF2-extensions as Answer-set Models," 2012.
- [13] M. Caminada, "On the issue of reinstatement in argumentation," *Logics in artificial intelligence*, 2006.
- [14] G. Marreiros, R. Santos, C. Ramos, and J. Neves, "Context Aware Emotional Model for Group Decision Making," *IEEE Intelligent Systems (2010)*, pp. 1–7, 2011.
- [15] R. Santos, G. Marreiros, and C. Ramos, "Personality, Emotion and Mood in Agent-based Group Decision Making," *IEEE Intelligent Systems (2011)*, vol. 26, no. 6, pp. 58–66, 2011.
- [16] S. Kraus, K. Sycara, and A. Evenchik, "Reaching agreements through argumentation: a logical model and implementation," *Artificial Intelligence*, no. June 1998, 1998.
- [17] T. Bench-Capon, S. Doutre, and P. Dunne, "Audiences in argumentation frameworks," *Artificial Intelligence*, no. December, 2007.
- [18] C. Cayrol, F. de Saint-Cyr, and M. Lagasque-Schiex, "Revision of an argumentation system," *Proc. of KR*, pp. 1–22, 2008.

Intelligent Outdoor Spaces

Peter MIKULECKY^{a,1}

^a*Department of Information Technologies, Faculty of Informatics and Management,
University of Hradec Kralove, Czech Republic*

Abstract. There are a number of recent wide area wireless sensor networks applications focused on environmental monitoring. However, there is just a few of them that aim to connect the data collecting and processing power with approaches and technologies of ambient intelligence. In our paper we intend to go further on with the ideas how ambient intelligence used in wide manner in connection with wireless sensor networks throughout the open natural environment could be beneficial not only for early warning in case of possible disasters, but also as a supporting tool for people located from various reasons in various outdoor areas. These can be hitchhikers, hikers on difficult mountains tracks, or even workers in an exacting outdoor workplace (i.e., coal mine). An idea of a large-scale ambient intelligence system based on a wide area wireless sensor network is presented, where the system could be able of monitoring the environment, evaluating the collected data and, if necessary, informing the workers in the environment about possible threats and possibly giving some hints for their rescue using their mobile devices. Such “intelligent outdoor spaces” could use already existing and matured technology of both wireless sensor networks and ambient intelligence with a clear benefit for people situated there.

Keywords. Ambient intelligence, wide area sensor networks, environmental applications, outdoor spaces, early warning.

Introduction

First ideas about Ambient Intelligence used in a large scale manner firstly appeared in [1]. In addition to incorporating intelligence in sensor nodes within a wide area wireless sensor network, the authors of [1] proposed to upgrade this vision to the next level where these geographically distributed intelligent sensor networks would become intelligent sensor resources accessible to the users anytime-anywhere. In our earlier papers [2] and [3] we started with some contemplations related towards possibilities of using large-scale ambient intelligence approaches and applications in a number of environmental problems.

In this paper we intend to go further on with the ideas how ambient intelligence used in “large-scale” throughout the open natural environment could be beneficial in supporting people located at various outdoor places. We present here some contemplation about possibilities for outdoor large-scale ambient intelligence focused on such outdoor spaces, where a wide area wireless sensor network will be able, apart from its monitoring role, also of evaluating possible threats from the

¹ Faculty of Informatics and Management, University of Hradec Kralove, Rokitanského 62, Hradec Králové 50003, Czech Republic; Email: peter.mikulecky@uhk.cz

environment and sending early warning information, if not starting a supporting rescue action for people situated at various places in the monitored environment.

1. Problem Definition

The environmentally oriented wireless sensor networks [4] are in our opinion matured enough to become a basis for more complex support of various outdoor activities. As Efstratiou [5] pointed out, wireless sensor networks are more and more seen as a solution to wide area tracking and monitoring applications, but, these networks are usually designed to serve a single application and collected information is commonly available to one authority, usually to the owner of the sensor network. According to [5], the vision for the future generation of sensor networks is of a world where sensing infrastructure is a shared resource that can be dynamically re-purposed and reprogrammed in order to support multiple applications. Furthermore multiple sensor networks (possibly owned by different authorities) can be combined in a federated fashion in order to create a more complete picture of the world.

We certainly share this opinion and propose an idea of a complex ambient intelligence system over a wide area wireless sensor network implemented in a potentially risky natural environment (mountain areas, surface mines, seashores, river basins or water reservoirs, forests, etc.) that will perform the following tasks:

- monitoring the usual hydro-meteorological parameters of the environment (air pressure, temperature, humidity, soil moisture, etc.),
- monitoring indications of possible threats (seismo-acoustic signals, smoke, water on unusual places, etc.),
- monitoring appearance and movement of animals and human beings in the area,
- evaluating the data collected from the sensor network and identifying possibly dangerous situations,
- identification of possibly endangered human beings in the area under monitoring,
- attempting to contact the persons in danger possibly via their mobile devices and starting to provide all the necessary information and knowledge support aiming to help them to escape from the dangerous situation (including eventual alarming of a rescue squad.)

An AmI system working over such a sensor network will be able of evaluating all the data collected and decide about possible active intervention in the environment aiming to help people located at outdoor spaces under threat.

2. Related Works

Outdoor oriented applications of Ambient Intelligence approaches should be prevailingly based on recent achievements in the area of wide area wireless sensor networks. Let us describe shortly a couple of related works oriented on this area.

Tremendous effort has been devoted recently to the area of sensor networks and their important applications, as mentioned in [6]. A wireless sensor network is usually a

combination of low-cost, low-power, multifunctional miniature sensor devices consisting of sensing, data processing, and communicating components, networked through wireless link. In a typical application, a large number of such sensor nodes are deployed over an area with wireless communication capabilities between neighboring nodes.

There is a number of works dealing with technical possibilities of sensor networks. The book [6] lists a number of results, oriented on context-awareness of sensors and sensor networks. The idea behind is, that if sensors could know more about their own context, then they could adapt their behavior and function only when needed and to the extent adequate to the current circumstances. This aspect can be important also for power consumption by the sensor. A lot of work has been done by [7], [8] or [9], a useful book on sensor networks is [10].

For instance, Cardell-Oliver and her colleagues [7] proposed a novel reactive soil moisture sensor network that reacts to rain storms in such a way, that frequent soil moisture readings were collected during rain (approx. every 10 minutes), but less frequent readings (once a day) were collected when it is not raining. The network includes a node with a tipping bucket rain gauge sensor and, in another part of the landscape, a group of nodes with soil moisture sensors. The node monitoring rain is separated from the nodes monitoring soil moisture, and yet these nodes need to share information, whilst minimizing the time spent sending, receiving and listening to messages.

Among a number of recent interesting environmental applications, we can mention the FieldServer Project [11], and the Live E! Project [12].

The FieldServer Project is oriented on development and networked applications of so-called Field Servers. A Field Server [11] is a wireless sensor network that will enhance the monitoring of environmental factors by allowing sensing nodes to be located at precise locations in fields, reducing overhead installation costs, and allowing for real-time data collection. For instance, in Japan, Field Servers were developed for applications at farms. They produce real-time images for security guards, and environmental data for farming. Agronomists, physiologists, and ecologists can exploit high-resolution real-time images in order to react on any specific situation that could appear in the environment. Many types of Field Servers have been developed up to now.

The second example, the Live E! Project [12] is an open research consortium to explore the platform to share the digital information related to the living environment. Using the low cost weather sensor nodes with Internet connectivity, a nationwide sensor network was deployed [12]. The network has accommodated more than 100 stations. The application of this weather station network is intended for disaster protection/reduction/recovery and also as educational material for students.

One of the most significant drivers for wireless sensor network research is environmental monitoring. Its potential will not only enable scientists to measure properties that have not previously been observable, but also by ubiquitous monitoring the environment and supplying the related data to relevant supervising bodies, they can create a basis of early warning systems for various environmental disastrous situations and their management. As [13] points out, the relatively low cost of the wireless sensor networks devices allow the installation of a dense population of nodes that can adequately represent the variability present in the environment. They can provide various risk assessment information, like for example alerting farmers at the onset of frost damage. Wireless sensor networks based fire surveillance systems were designed

and implemented, as well. They can measure temperature and humidity, and detect smoke following by early warning information broadcasting [14]. Sensors are able to consider certain dynamic and static variables such as humidity, the type of fuel, slope of the land, the direction and the speed of the wind, smoke, etc. They also allow determining the direction and possible evolution of the flame front.

In our earlier papers [15], [16] and [17] we started with some contemplations related towards possibilities of using ambient intelligence approaches in water management. According to Yang [18], watershed management administers water resources within a watershed for different water users. The ultimate purpose of watershed management plan is to maximize the profits of different users meanwhile reducing the possible conflicts that might occur between them. Watershed management can be very efficiently modelled using multi-agent systems, nevertheless, there is just a few works taking into account also catastrophic situations (see, e.g., [19]).

However, apart from other similarly serious environmental disasters, floods are responsible for the loss of precious lives and destruction of large amounts of property every year, especially in the poor and developing countries. A lot of effort has been put in developing systems which help to minimize the damage through early disaster predictions (see, e.g., [20]). On the other hand, as drought periods, opposite to floods, cause lot of damage every year as well [21], also this problem deserves high effort. Interesting solutions to the problems can be found e.g. in [22], [23], or [24].

3. Proposed Approach

In order to support a person's activities outdoor, her/his geographic location must be identified as an important contextual information that can be used in a variety of scenarios like disaster relief, directional assistance, context-based advertisements, or early warning of the particular person is some potentially dangerous situations. GPS provides accurate localization outdoors, although it is not very useful inside buildings.

Based on ideas presented by Iqbal and others in [1], we can think about *Large-scale Ambient Intelligence* as a large set of geographically widely distributed intelligent sensor resources with the main purpose of increasing significantly intelligence of various segments of real nature. By a smart sensor resource we shall mean a kind of ambient artefact, namely a combination of an advanced sensor with ubiquitously computing and communicating processor integrated with the sensor. Their purpose will be given by their main tasks, so that a number of their specific types could be possible. Let us mention a couple of them:

- smart water level guards;
- smart soil humidity sensors;
- smart forest fires guards;
- smart wind velocity sensors;
- and a couple of others.

Speaking about *guards*, we shall mean special kind of intelligent sensors applicable namely for early warning purposes in such cases, when e.g. the water level increase achieves some given gradient, or when temperature in a segment of a forest overreached the given level. In such a case the intelligent sensor resource will

communicate a kind of alarm which will be propagated through whole sensor network and immediately elaborated further on by the responsible parts of the network.

Multi-agent architectures seem to be applicable here, as it is common in the case of large networks of sensors. We can tract various types of intelligent sensors and guards as agents with appropriate level of intelligence, recent dispatchers or even dispatching centres can be modelled as supervising agents (e.g., river basin management dispatching centres or fire brigades dispatching centres, etc.).

Outdoor acting person's support should provide relevant and reliable information to users often engaged in other activities and not aware of some hazardous situations that he or she could possibly encounter. There are only a small number of attempts to solve the related dangerous situations that can be described using the following scenario:

A user appears in a natural environment performing her/his working mission, a kind of leisure time activity (hiking tour, mountaineering, cycling, etc.), or because of being an inhabitant of the area. A sudden catastrophic situation (storm, flash flood, debris flow, etc.) could put the person in a risky, if not a life endangering situation. The "intelligent outdoor space" based on a federated wireless sensor network is ubiquitously monitoring the area and estimating the possible appearance of a dangerous situation. If necessary, the network will proactively broadcast an early warning message to the user, offering her/him related navigation services supporting escape from the dangerous situation. This message can be delivered via a mobile device of the user, if the user subscribed it prior to entering the outdoor area, but the cases without subscription should be solved as well.

In the literature, there is only a little works oriented on a kind of a service to the potentially endangered persons in a natural environment; however, this service is never such complex as in our scenario.

For instance, there are some attempts of preventing children from potentially dangerous situations in an urban environment. Probably the first ubiquitous system to assist the outdoor safety care of the schools kids in the real world is described in [25].

A number of papers are devoted to various solutions for tourist assistance, mainly oriented on context-aware tourist navigation on their routes. The usual approach is in deployment of intelligent agents, which collectively determine the user context and retrieve and assemble a kind of simple information up to multi-media presentations that are wirelessly transmitted and displayed on a Personal Digital Assistant (PDA). However, these tourism oriented applications are usually deployed for the navigational purposes, without having capabilities of warning the user from potentially dangerous situations that can appear during their routes.

As an example of an in a sense similar system we refer to [26]. The deployed sensor network aimed to assist the geophysics community, and in contrast with at that time existing volcanic data acquisition equipment the used nodes of the sensor network were smaller, lighter, and consumed less power. The resulting spatial distribution greatly facilitated scientific studies of wave propagation phenomena and volcanic source mechanisms. Certainly, we can imagine a number of potentially dangerous situations that can endanger people working closely to the volcano. Enhancing the purely geophysical sensor networks by the features mentioned above could improve the safety of working near the volcano.

Another example belongs also to the area of potentially dangerous workplaces. The result of [27] seems to be one of those attempts that aimed directly at developing a sensor networks for monitoring possible dangerous situations (gas

explosion) in a large yet closed environment - a coal mine in China. In this system also a localization of miners in the coal mine is implemented, however, there is no possibility how to start some rescue actions by the system itself, by processing the results supplied by the network nodes automatically. Nevertheless, the experience with this sensor network in a Chinese coal mine is good and inspirational, according to [27].

In order to design some solution for outdoor spaces we can imagine a number of sensors acting as various kinds of guards. Let us present some examples, which are technologically feasible and frequently used in large-scale wireless sensor networks:

- water level guards, monitoring surface water level, or even groundwater level and watching over potentially dangerous or at least unusual situations.
- water quality guards, monitoring surface and groundwater quality and watching over possible contaminations or pollutions.
- air pollution guards, monitoring air quality, watching over possible pollutions.
- wind velocity sensors, monitoring wind velocity and watching over potentially dangerous situations.
- soil moisture sensors, measuring level of soil humidity, e.g. in forests, or in a river watershed, aiming at monitoring the degree up to which is the land segment saturated by water, and measuring the capacity of further possible saturation.

Of course, other kinds of intelligent sensors integrating ubiquitous monitoring (computing) of measured parameters with ubiquitous communication with other sensors – agents – in the area are possible as well.

We believe that the main application area for large-scale ambient intelligence will be any kind of prevention, connected with early warning facilities. Such areas as fire prevention, water floods prevention and early warning, or accident prevention in urban traffic could be clear candidates.

In water floods prevention area we can imagine the usage of the following agents:

- water level monitoring agents;
- land segments saturation (moisture) guards;
- water reservoir handlers;
- supervising agents.

The concept of our solution to the problem e.g., water floods, could consist of the following steps:

- Establishing a large-scale wireless sensor network, consisting of, e.g., water level guards, completed by a number of sensor sub-networks, composed from soil moisture guards, situated in those land segments that are already known as critical from the soil saturation point of view.
- The established large scale wireless sensor network will be embedded in a multi-agent architecture, where the particular sensor sub-networks of various types will play roles of group of agents in the multi-agent architecture.
- The special roles are assigned to manipulating agents, as are, e.g., water reservoir handlers, or river weirs manipulators.
- The whole system can be designed as hierarchical, as there could be a number of concentrators (agents collecting the data) as well as messages from the

groups of agents defined in the previous steps. These concentrators then communicate mutually as well as with the supervisor that is an agent with the task of evaluating the data as well as messages.

- Further on, the supervising agent will evaluate the messages from the lower level agents, and after judging the level of their importance it will start a respective action, or a whole sequence of actions, adequate to the situation appraised.
- The supervising agent will communicate also with localization agents, which are responsible for keeping information about the people localized in the monitored area. If the supervising agent evaluates the whole situation as dangerous for localized people, it will then send a request to the communicating agents to send an urgent message to the PDA's of the monitored people with a hint what to do in order to escape from the danger.

Similar solutions can be imaged also for other dangerous situations that are likely to appear in an outdoor space. These will be elaborated in a detail further on in other publications. Some our work in this direction has been already published in [3], [15], [28], or [29].

4. Conclusions

In the paper, after a short analysis of various recently used approaches, we presented an idea of a large-scale ambient intelligence application over a wide environmental sensor network aiming at monitoring and possibly early warning in cases of threats from the monitored outdoor environment. The system should be primarily focused on outdoor workplaces and workers acting there, however, it could be beneficial for all the people located in the monitored outdoor space. Their mobile devices can be naturally used for communicating with the monitoring system, with a possibility of prescription the desired messaging or warning service. The idea of just described intelligent outdoor spaces is in further development recently. We hope, that such intelligent outdoor spaces could become reality in the short time, contributing thus to saving many lives of potentially endangered people.

Acknowledgments

This research has been partially supported by the Czech Science Foundation project „*Information, cognitive, and interdisciplinary support of research – INKOV*”, Reg. No. CZ.1.07/2.3.00/20.0001, which is co-financed by the European Social Fund as well as by the state budget of the Czech Republic.

References

- [1] M. Iqbal, et al., A sensor grid infrastructure for large-scale ambient intelligence. In 2008 Ninth International Conference on Parallel and Distributed Computing, Applications and Technologies, 468-473, IEEE (2008).

- [2] P. Mikulecky, Large-scale ambient intelligence. In *Advances in Data Networks, Communications, Computers* (N. Mastrokakis, V. Mladenov, eds.), Proc. of the 9th WSEAS Conference on Data Networks, Communications, Computers, p. 12, WSEAS Press (2010).
- [3] P. Mikulecky, Large-scale ambient intelligence – Possibilities for environmental applications. In *Ambient Intelligence Perspectives II* (eds. P. Čech, V. Bureš and L. Nerudová), Volume 5 Ambient Intelligence and Smart Environments, IOS Press, pp.3-10 (2010).
- [4] J.K. Hart, K. Martinez, Environmental sensor networks: A revolution in the earth system science?, *Earth-Science Reviews* **78** (2006) 177 – 191.
- [5] Ch. Efstratiou, Challenges in supporting federation of sensor networks. In *NSF/FIRE Workshop on Federating Computing Resources* (2010).
- [6] S. Loke, *Context-Aware Pervasive Systems*. Auerbach Publications, Boca Raton (2007).
- [7] R. Cardell-Oliver, K. Smettem, M. Kranz, K. Mayer, A reactive soil moisture sensor network: Design and field evaluation. *Int. Journal of Distributed Sensor Networks* **1** (2005), 149-162.
- [8] E. Elnahrawy, B. Nath, Context-aware sensors. In Proc. 1st European Workshop on Wireless Sensor Networks, 77-93 (2004).
- [9] Q. Huai Feng, Z. Xingshe, Context-aware Sensornet. In Proc. 3rd International Workshop on Middleware for Pervasive and Ad-Hoc Computing, Grenoble, ACM Press, 1-7 (2005).
- [10] S. Misra, I. Woundgang, S.C. Misra, (eds.), *Guide to Wireless Sensor Networks*. London: Springer Verlag (2009).
- [11] S. Ninomiya, T. Kiura, A. Yamakawa, T. Fukatsu, K. Tanaka, H. Meng, M. Hirafuji, Seamless integration of sensor network and legacy weather databases by MetBroker. In 2007 International Symposium on Applications and the Internet Workshops (SAINTW'07), IEEE, 68 (2007).
- [12] S. Matsuura, et al., LiveE! Project: Establishment of infrastructure sharing environmental information. In 2007 International Symposium on Applications and the Internet Workshops (SAINTW'07), IEEE, 67 (2007).
- [13] L. Ruiz-Garcia, L. Lunadei, P. Barreiro, J.I. Robla, A review of wireless sensor technologies and applications in agriculture and food industry: State of the art and current trends. *Sensors* **9** (2009) 4728-4750.
- [14] J. Lloret, M. Garcia, D. Bri, S. Sendra, A wireless sensor network deployment for rural and forest fire detection and verification. *Sensors* **9** (2009) 8722-8747.
- [15] P. Mikulecky, K. Olsevicova, D. Ponce, Knowledge-based approaches for river basin management. *Hydrol. Earth Syst. Sci. Discuss.* **4** (2007) 1999–2033.
- [16] P. Mikulecký, D. Ponce, M. Toman, A knowledge-based decision support system for river basin management. In: *River Basin Management II*, C.A.Brebbia, Ed., pp. 177-185, Southampton: WIT Press (2003).
- [17] P. Mikulecký, D. Ponce, M. Toman, A knowledge-based solution for river water resources management. In: *Water Resources Management II*, C.A. Brebbia, Ed., pp. 451-458, Southampton: WIT Press (2003).
- [18] L.-C. Yang, *Modeling Watershed Management with an Ecological Objective - A Multiagent System Based Approach*. PhD Dissertation, University of Illinois at Urbana-Champaign, (2010).
- [19] L. Brouwers, K. Hansson, H. Verhagen, M. Boman, Agent Models of Catastrophic Events. In Proceedings of Modelling Autonomous Agents in a Multi-Agent World, 10th European workshop on Multi Agent Systems, Annecy (2001).
- [20] V. Seal, A. Raha, S. Maity, A Simple Flood Forecasting Scheme Using Wireless Sensor Networks. *International Journal of Ad hoc, Sensor & Ubiquitous Computing (IJASUC)* **3** (2012) 45-60.
- [21] H.-Y. Kung, J.-S. Hua, C.-T. Chen, Drought Forecast Model and Framework Using Wireless Sensor Networks. *J. of Inf. Science and Engineering* **22** (2006) 751-769.
- [22] R. Marin-Perez, J. García-Pintado, A. Skarmeta Gómez, A real-time measurement system for long-life flood monitoring and warning applications. *Sensors* **12**, (2012) 4213-4236.
- [23] Y. Zhang, L. Luo, J. Huo, W. Zhu, An Eco-Hydrology Wireless Sensor Demonstration Network in High-Altitude and Alpine Environment in the Heihe River Basin of China. *Wireless Sensor Networks* **4** (2012) 138-146.
- [24] E. Basha, D. Rus, Design of Early Warning Flood Detection Systems for Developing Countries. In: Proceedings of the Conference on Informations and Communication Technologies and Development, Bangalore, India, (2007).
- [25] K. Takata, Y. Shina, H. Komuro, et al., Designing a context-aware system to detect dangerous situations in school routes for kids outdoor safety care. In L.T. Yang et al. (Eds.): *EUC 2005*, LNCS 3824, pp. 1016-1025, Berlin: Springer (2005).
- [26] G. Werner-Allen, K. Lorincz, M. Welsh, et al., Deploying a wireless sensor network on an active volcano. *IEEE Internet Computing*, **10** (2006), 18-25.

- [27] X. Wang, X. Zhao, Z. Liang, M. Tan, Deploying a wireless sensor network on the coal mines. In Proceedings of the 2007 *IEEE International Conference on Networking, Sensing and Control*, London, UK, pp. 324-328 (2007).
- [28] P.Mikulecký, K.Olševičová, R.Cimler, Outdoor Large-scale Ambient Intelligence. *IBIMA*, 2012.
- [29] P. Mikulecky, Ambient intelligence and smart spaces for managerial work support, *Intelligent Environments, IE 07*. 3rd IET International Conference, 560-563, 24-25 Sept. 2007.

Simulation of Visitor Flow Management with Context-based Information System

Kamila OLŠEVIČOVÁ^{a,1} and Richard CIMLER^a

^a *Department of Information Technologies, Faculty of Informatics and Management,
University of Hradec Kralove, Czech Republic*

Abstract. We discuss utilization of agent-based models and agent-based social simulations in the process of smart application development. We present the concept of personalized context-based information system for visitors of the ZOO. The visitor flow model is enhanced with simulation of smart application that assists visitors by sending information and recommendations to their mobile devices. In general our model illustrates the idea of smart application in tourism and it allows exploring possibilities of how to manage visitor flow in natural and cultural destinations, how to eliminate crowding or how to increase the satisfaction of visitors by relevant scenarios.

Keywords. agent-based model, context-based information, visitor flow, simulation, smart application, tourism

Introduction

Ambient intelligence (AmI) and smart applications are dedicated to individuals or groups of users sharing the indoor environment (intelligent house, smart office) or outdoor environment (natural or cultural destinations). Current trend is to develop large-scale applications, based on a combination of multifunctional devices consisting of sensing and communicating components. Large number of sensors can be deployed over an area with wireless communication between neighbouring nodes [1]. Typically the applications process sensor data to track and monitor users and to provide further assistance and context-aware services (e.g. navigation, providing information, warning). Mobile devices (phones, tablets, watches etc.) of people currently situated in the given location can become part of the smart infrastructure.

When designing large-scale AmI applications, it is important to explore not only characteristics, behaviour and context of individual users, but also the effects (and side-effects) of coexistence of numerous users at the same time and place. To better understand these effects we recommended using agent-based models and agent-based social simulations [2]. Particularly in relation to sustainable tourism planning and development, coupled *visitor flow model* and *infrastructure model* can illustrate the idea of smart application and can allow us to explore possibilities that we might not have thought of otherwise.

¹ Corresponding Author: Faculty of Informatics and Management, University of Hradec Kralove, Rokitanského 62, Hradec Králové 50003, Czech Republic; Email: kamila.olsekovicova@uhk.cz

In the following part of the paper we discuss the utilization of agent-based models and agent-based social simulations in tourism. Then we demonstrate the idea of a particular smart application. To achieve this, we developed the NetLogo model of context-based information system for the visitors of ZOO. We describe the model and present experimental results.

1. Models and Simulations for Ambient Intelligence

Agent-based models (ABM, also individual-based or bottom-up models) is an approach to modelling complex systems composed of heterogeneous adaptive individuals (agents) interacting in the environment. ABM is particularly applicable when agents' adaptation and emergence are important considerations. The principles of ABM were explained by numerous authors including [3,4,5]. The overview of ABM software is provided by [6] and others. Recent applications of ABM span a broad range of areas and domains from modelling electric power markets over predicting the spread of epidemics to understanding the fall of ancient civilizations [7]. Social science is one of first research fields wherein an ABM approach has been broadly applied. Probably the first well-known and inspiring model was the Schelling's space-time model of residential segregation [8,9] Brief explanation of the area of Agent Based Social Simulation (ABSS) from a computer scientist's perspective is presented in [10].

In relation to Ambient Intelligence, ABM was suggested to be used for simulating and verifying the functioning and effectiveness of complex applications, see e.g. Ubik simulation platform [11]. When thinking about large-scale outdoor Aml applications, it is interesting to take into account ABM and ABSS of transport, traffic and also crowd and pedestrian models. Various models of particular aspects of movement of individuals and groups in the environment can provide us deeper insight and better understating of effects of the personalised context-based smart applications.

Specialized agent-based transport and traffic simulation platforms are already available, see e.g. Multi-Agent Transport Simulation framework [12] for large-scale transport modelling. Case studies designed in MatSIM visualize the traffic in different locations, demonstrate the process of evacuation from the coastline attacked by the tsunami wave etc. Pedestrian dynamics models are objective of intensive research and agent-based modelling is only one possible ways. Other approaches are based on particle models and cellular automata [9] Traffic and pedestrian models typically build on GIS data (maps) and different data sources capturing characteristics and behaviour of individuals (e.g. national census). Large models often work with samples of the whole population precisely transformed to the comparable synthetic population.

In tourism, ABM and ABSS can facilitate planners and decision makers to develop and implement strategic policies for sustainable development [13]. For example [14] presents a GIS and ABMS of actions of individual visitors using travel pattern data. The visitor flow modelling in tourism is closely related to the concept of the Tourist Carrying Capacity (TCC) which is defined by World Tourism Organizazion as *the maximum number of people that may visit a tourist destination at the same time, without causing destruction of the physical, economic, socio-cultural environment and an unacceptable decrease in the quality of visitors' satisfaction*. We can see the concept of TCC as a kind of metric of success of smart application.

The method of developing ABM and ABSS that we intend to use is presented in [15,16]. NetLogo [17] software was chosen for the implementation.

To illustrate the approach of application of ABM and ABSS in context of Ambient Intelligence for tourism, we developed the NetLogo model of personalized context-based information system dedicated to visitors of the zoological park. The main idea is to create a realistic simulation of visitor flow and then to simulate the smart infrastructure and observe its effects. Our model enables:

- *simulating visitor flow*, i.e. trajectories of visitors, their spatial and temporal behavior and movement patterns,
- *evaluating crowding* in the area, i.e. monitoring numbers of visitors at different places, measuring crowding and carrying capacities,
- *demonstrating functions of personalized context-based smart application* and measuring its impact on trajectories of visitors and crowding.

2. Visitor Flow Model

The visitor flow model has got two inputs: the map of the ZOO and the arrival rates of visitors during the opening hours.

The map is converted to the weighted network of nodes, representing entrance/exit and 19 places of visitors' interest (15 animal houses, 2 souvenir shops, 2 restaurants). Each node has got its capacity (1-100 visitors) and attractiveness (1-10 points). Edges of the network represent sidewalks with its lengths (10-100 meters). In NetLogo model, 1 patch corresponds to 10x10 m².

The ZOO opens at 8:00 a.m. and closes at 19:00 p.m. The last visitors can enter at 18:00. One tick of the model clock corresponds to 1 minute. Every minute new coming visitors are created. The Poisson distribution with the mean value given by arrival rates settings is used. Arrival rates are defined separately for morning (8-10 a.m., 10-12 a.m.), midday (12-14 p.m.) and afternoon (14-16 p.m., 16-18 p.m.). The simulation takes 660 steps correspondingly to 660 minutes (11 hours).

A *visitor-agent* represents a single visitor, a couple or a family. The visitor-agent has got following 6 attributes:

- number of persons (1-6),
- language (60% visitors are Czechs, 20% are Germans, the rest is expected to speak English; the suggested smart application will send messages in relevant language),
- total time limit for visit (2-6 hours),
- mobile device (yes-no; for simplification the visitors without a device are those who do not want to use the smart application; their presence in the model is important – and challenging – for realistic thinking about the proposed application),
- walking speed (50, 80 or 100 meters per minute),
- want-to-see list of favourite animals (0-15) – visitor-agent tends to spend 2-15 minutes to watch his/her favourite animals, but only 0-3 minutes at non-preferred places.

Two types of movement behaviour of visitor-agents around the ZOO are defined:

- *guided tour* – most visitor-agents follow it, a minority changes direction randomly; the total distance of the guided tour in the map is about 1,5 km,

- *random tour* – all visitor-agents move partly randomly, partly according their lists of want-to-see places. The visitor-agent navigates from the node to the node (preferring items from his want-to-see list, places with higher attractiveness and not yet visited places), the average walking distance is about 2,1 per visitor-agent.

The type of tour (guided or random) and arrival rates are basic parameters of the visitor flow simulation. Outputs of the model are:

- visualization of workload of each node of the network (total and current capacity of each animal house, restaurant or shop),
- monitors and plots with changing numbers of visitor-agents during the day, their total time spent in the ZOO and total walking distance.

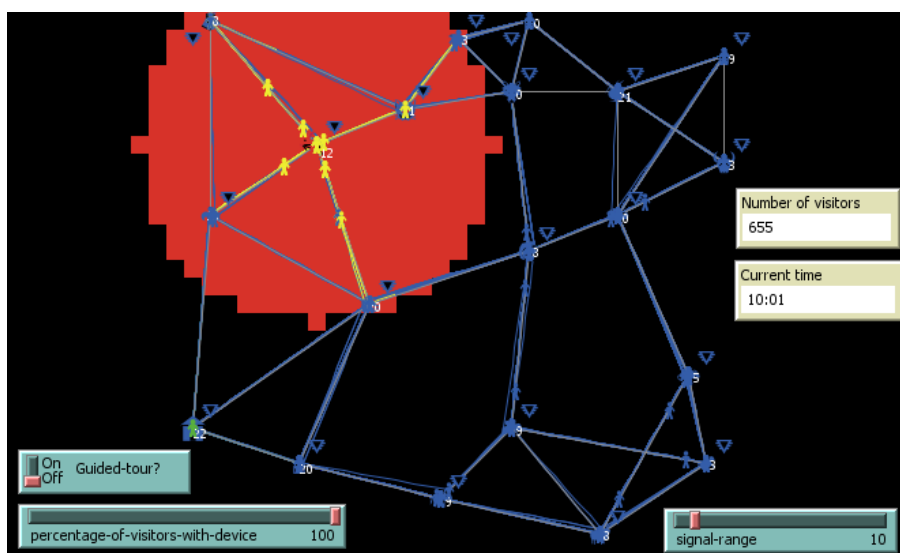

Figure 1. Visualization in NetLogo: network of nodes with visitor-agents at their current positions, switch for setting the type of tour (guided or random), slider for setting the share of users of the smart application, slider for setting the range of messages broadcasting

3. Smart Application Model

The attractiveness of animal houses in the ZOO changes during the day because different animals are more or less active in the morning and in the afternoon, some animals are presented to visitors (e.g. animal keepers feed tigers or do exercise with elephants). Visitors prefer to see active animals. Therefore we extended the visitor flow model to demonstrate how relevant smart application could work.

The application scenario is as follows. The visitors who have some mobile device (cell phone or tablet) and are willing to use the smart application can provide their data (preferred language and list of favourite animals). Then visitors can be addressed by personalized context-based textual information. For example, people who are fond of primates or who are currently situated close to the primates house, can obtain the

message (in Czech, German or English) inviting them to the house with some free capacity and upcoming presentation. The question is how the system of messages will affect the visitor flow, how non-users of the smart application should be captured in the model (and in the scenario), or how to increase the satisfaction of visitors by highly relevant messages. The model is designed to enable experimenting in relation to these questions.

The main input of the model is a share of visitor-agents using the smart application and the probability that the visitor-agent accepts the invitation.

Output of the model consists of the visualization of smart infrastructure functioning (i.e. areas covered by sensors and broadcasting) and different monitors and plots.

4. Experiments

BehaviourSpace tool in NetLogo was used for simple evaluation of the model. We repeated the simulation 20-times for each experimental setting. The simulated population was around 1500 visitors per day (Figure 2).

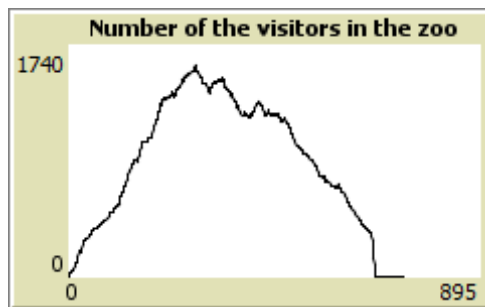

Figure 2. Number of visitors during the day

Experiment 1

Table 1. Experiment 1 - settings

Parameter	Values
Arrival rate 8-10 a.m.	2.7
Arrival rate 10-12 a.m.	4.1
Arrival rate 12-14 p.m.	3.4
Arrival rate 14-16 p.m.	3.1
Arrival rate 16-18 p.m.	1.5
Type of tour	Guided, Random
Smart application	ON, OFF
Probability of accepting the invitation	0.6

The objective of the first experiment was to compare the behaviour of visitor-agents in relation to the type of tour and the presence of smart application. The setting of the first experiment is defined in Table 1, results are shown in Table 2.

Table 2. Experiment 1- results

Type of tour	AVG Distance (km)	AVG Time (min)	AVG Visited events
Random tour, smart application OFF	2,04	160	0.697
Random tour, smart application ON	2,19	161	0.810
Guided tour, smart application OFF	1,43	143	0.391
Guided tour, smart application ON	1,62	147	0.486

Experiment 2

The objective of the second experiment was to compare the satisfaction of visitors in relation to the share of users of the proposed smart application. The setting of the first experiment is defined in Table 3, results are shown in Table 4. With the higher number of users, the average visitor-agent visits higher number of special events.

Table 3. Experiment 2- settings

Parameter	Values
Arrival rate 8-10 a.m.	2.7
Arrival rate 10-12 a.m.	4.1
Arrival rate 12-14 p.m.	3.4
Arrival rate 14-16 p.m.	3.1
Arrival rate 16-18 p.m.	1.5
Type of tour	Random
Users of smart application	0, 25, 50, 75, 100%
Probability of accepting the invitation	0.6

Table 4. Experiment 2- results

Users of smart application	Visitors at events (total / with application)
0 %	1025 / 0
25 %	1136 / 355
50 %	1205 / 695
75 %	1336 / 1077
100 %	1410 / 1410

5. Conclusion

Our NetLogo model demonstrates the functioning of personalised context-based smart application for tourists. Firstly we created the agent-based model of visitor flow in the given location. Then we added the model of networked sensors and active devices for monitoring visitors' movement and distribution of relevant context-based messages to their mobile devices. Hopefully such smart application could increase the satisfaction of visitors (and also eliminate crowding). Surely it is not possible to control all visitors in this way. In fact, part of visitors who are not users of the smart application, represent a challenge for the designer of the application. Our sample model was created for a specific destination – the zoological park – but analogically it could be designed for museums or botanical gardens. Further research is focused on:

- *refining the visitor flow model* and its calibration using real data,
- *optimizing the infrastructure model* in relation to practical hardware requirements for sensors and active devices,

- *defining smart application scenarios* with more types of messages and corresponding organizational issues (e.g. distributing quizzes or sponsoring proposals to devices of relevant users).

Acknowledgement

The research described in the paper was financially supported by grants GACR-402/09/0405, CZ.1.07/2.3.00/20.0001 INKOV and UHK specific research project no.2104.

References

- [1] P.Mikulecký, K.Olševičová, R.Cimler, Outdoor Large-scale Ambient Intelligence. IBIMA, 2012.
- [2] K.Olševičová, Ambient Intelligence, Agents and NetLogo. *Ambient Intelligence Perspectives II*, P.Čech (ed.), IOS Press. 2009. pp.77-83.
- [3] C.M.Macal, M.J.North, Tutorial on agent-based modeling and simulation. *Proceedings of the 37th Winter Simulation Conference*. 2005. pp. 2-15.
- [4] C.M.Macal, M.J.North, Tutorial on agent-based modeling and simulation part 2: how to model with agents. *Proceedings of the 38th Winter Simulation Conference*. 2006. pp. 73-83.
- [5] C.M.Macal, M.J.North, Tutorial on agent-based modelling and simulation. *Journal of Simulation*. 2010. 4, pp. 151-162.
- [6] S.F.Railsback, S.L.Lytinen, S.K.Jackson, Agent-based Simulation Platforms: Review and Development Recommendations. *Simulation* . 2006, 82(9), pp. 609-623.
- [7] S.F.Railsback, V.Grimm, *Agent-Based and Individual-Based Modeling*. Princeton University Press. 2012.
- [8] N.Gilbert, K.G.Troitzsch, *Simulation for the Social Scientist*. Open University Press, 2005.
- [9] A.M.Ullrmacher, D.Weyns (eds.) *Multi-Agent Systems: Simulations and Applications*. CRC Press. 2009.
- [10] P.Davidsson, Agent Based Social Simulation: A Computer Science View. *Journal of Artificial Societies and Social Simulation*. 5 (1), 2002.
- [11] E.Serrano, J.A.Botia, J.M.Cadenas, Ubik: a multi-agent based simulator for ubiquitous computing applications. *Journal of Physical Agents*, 3(2), 2009, pp. 39-43.
- [12] MatSIM, Multi-Agent Transport Simulation framework homepage, <http://www.matsim.org/> (2013)
- [13] E.Maggi, F.Stupino, F.L.Fredella, A multi-agent simulation approach to sustainability in tourism development. 51st European congress of the Regional Science Association International, , Barcelona, 2011
- [14] R.Zhang, Assessing the Carrying Capacity of Tourist Resorts: An Application of Tourists' Spatial Behavior Simulator Based on GIS and Multi-Agent System, Wuhan, University Journal of Natural Sciences, 10(4): 779-784 (2005).
- [15] V.Grimm, S.F.Railsback, *Individual-based Modeling and Ecology*. Princeton University Press. 2005.
- [16] V.Grimm, U.Berger, D.L.DeAngelis, J.G.Polhill, J.Giske, S.F.Railsback, The ODD protocol: A review and first update. *Ecological Modelling* 221 (23), 2010, pp. 2760-2768.
- [17] U.Wilensky, NetLogo. <http://ccl.northwestern.edu/netlogo/>. Center for Connected Learning and Computer-Based Modeling, Northwestern University. Evanston, IL., 2009

Activities Recognition in Intelligent Office Environment

Saifullizam PUTEH^a Ahmad LOTFI^{a,1} and Caroline LANGENSIEPEN^a

^a*School of Science and Technology*

Nottingham Trent University

Nottingham, NG11 8NS, United Kingdom

Abstract. In modern office environments, lighting systems, heating/cooling system and personal computers are the main energy consumers. Our aim is to minimise use of energy resources in the office environments while still taking account of user preferences and comfort. To achieve the goal, a data collection system is designed and built. This required a wireless sensor network to monitor a wide range of ambient conditions and user activities, and a software agent to monitor user's personal computer activities. Collected data from different users are gathered into a central database and converted into a meaningful format for description of the worker's Activity of Daily Working (ADW) and office environment conditions. An activity recognition model using an event-driven model is proposed to recognise a worker's activities during times when the office is occupied or unoccupied. The experimental results demonstrate the model recognises a worker's activities and can classify them into six categories (home, lunch, short break, out of office duties, not using computer and using computer) with accuracy of more than 90%.

Keywords. Activities of daily working, building management system, activity recognition, intelligent office, pervasive sensing, event-driven model

Introduction

Optimal use of resources in office environments while still taking account of user preferences and comfort is a new challenging area of research. An office environment equipped with appropriate sensory devices and actuators is required to be able to control the environmental conditions. Such an environment will be referred to as an "Intelligent Office" environment. Apart from the monitoring and control of the environment, there should be an intelligent decision-making process taking into account the office worker's Activities of Daily Working (ADW) and personal preferences. This will be referred to as a Building Management System (BMS). Therefore in an intelligent office, a BMS should allow integration and automation of all technologies and computational intelligence techniques to optimise energy consumption [1], occupants' well-being [2], safety [3] and work productivity [4].

Activities of office workers can be monitored using low level sensory devices to detect when they enter/leave the room, when they sit down at the desk, and when they use

¹Corresponding Author: Ahmad Lotfi, School of Science and Technology, Nottingham Trent University, Clifton Lane, Nottingham, NG11 8NS, United Kingdom; E-mail: ahmad.lotfi@ntu.ac.uk.

the computer. We can also monitor when they switch the light on/off, when they adjust the heating or leave the room (e.g. to get a drink). The aim of our research is to recognise activities using the low level information gathered from the environment. A user's activities must be recognised to distinguish between the time the office is unoccupied due to breaks/out-of-office duties, and the time that the office is unoccupied due to leaving at the end of the work day. The sensor based activity recognition is applied to generate the patterns of ADW and office power usage. These patterns can include the time that the an office user spends on out-of-office duties and also used computer or lighting.

This paper is organised as follows: in Section 1 of this paper a short summary of the related work regarding intelligent office environments is presented. In Section 2 the proposed system architecture and data collection are explained. Section 3 discusses the proposed technique for recognising office worker activity in an office environment. Details of our experiments are presented in Section 4. Section 5 draws some conclusions and discusses the contribution of the proposed methods for worker activity recognition in the intelligent office environment.

1. Related Work

The energy cost of a building is directly proportional to its capacity and hours of energy usage. For example, the study in [5] used private office buildings to find the relationship between energy usage and operation hours. In another study [6], it was found to be difficult to optimise the thermal comfort preferences of individuals in the office at all times. The important factors to be considered is that each individual has different thermal comfort satisfaction, and at different times and places an individual has different preferences of comfort in an office environment. In [7] they improved office efficiency based on heating, cooling and lighting to propose a future office environment. The study in [8] showed that social and personal factors can influence one's perceived health and comfort. In order to investigate individual comfort, it is necessary to investigate the relationship between personal, social and building factors.

In [9], surveys were conducted to assess the weighting given to intelligent criteria of buildings. The results showed that work efficiency is the most important selection criterion for various intelligent building systems, while user comfort, safety and cost effectiveness are also considered to be significant. This finding indicated that any intelligent office building system must perform efficiently to contribute to practicality and the building occupants' satisfaction.

A BMS is needed to integrate all intelligent building models to contribute comprehensive strategic management in all aspects, in order to analyse and report the office building performance, and then provide data analysis to any decision making system. It aims to provide intelligent functionality to respond to the energy demand and comfort of office building environments for normal daily operation. Research by [10] took into account the BMS to monitor daily energy operations in order to support the decision making process of selecting energy saving measures.

Human activity recognition and pattern discovery is explained in [11]. Tabak and deVries [12] examined the intermittent activities that interrupt the planned "normal" activities of office workers. They found that probabilistic and S-curve methods could be used to predict activities (such as "smoking", "go to toilet") and these could be used in

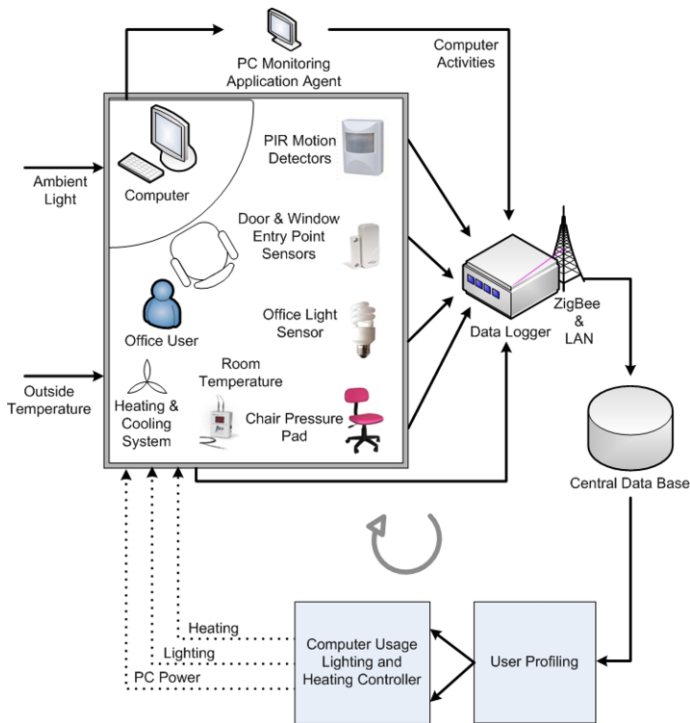

Figure 1. Proposed system architecture for intelligent office environment.

fine grained simulations of building performance. However, they cautioned that the results applied to typical Dutch office based organisations, and other office environments might need further experiments to generate data.

People's activity in a building is based on their schedule of work, lifestyle and social activity. Xin et al. [13] mentioned that one of the key features of an intelligent environment is to provide monitoring daily human activity. In many studies [14–16], human activity were monitored to assess activity of daily living in the building environment, and tried to process activity sequences to make them more understandable.

2. System Architecture and Data Collection System

The proposed system architecture is shown in Figure 1. The full monitoring and control system would use the information provided by the sensor, together with rules and algorithms deduced from the data mining to modify the environment such that the office worker found it optimal, while still achieving better energy consumption [17]. The office environment that we are using as the testbed for our experiment is the individual academic staff offices in the university campus. The proposed system comprises:

- sensors to measure user's activities and environmental properties,
- communication system to transfer collected data into a central database,
- Personal Computer (PC) monitoring application agent,

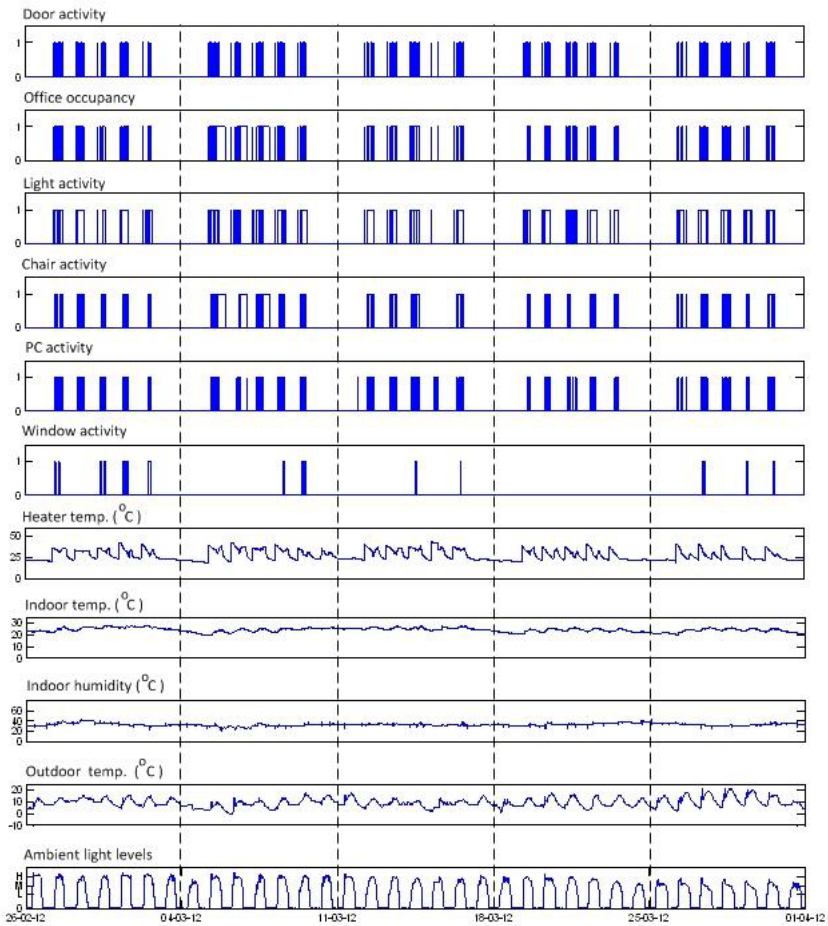

Figure 2. Sample of office signals representing a signals recorded by data collection system.

- a central database to store collected data,
- behaviour identification and user profiling,
- computer usage, lighting and heating controller.

The data collection system comprises a data logger collecting the environmental and behavioural responses collected from relevant sensors. Intelligent office environments are equipped with 11 sensors measuring different activities and properties of the testbed environment. Different types of sensors including Passive Infra-Red (PIR), Magnetic switch, temperature, humidity, light intensity, pressure pad sensors and also a PC monitoring application are used.

Sensor data is collected using a customised sensor network system and is stored in a database. A sample of the sensor signals representing working days is depicted in Figure 2. Interpretation of the data would become more difficult as more raw data is collected. Therefore, it is important to summarise the dataset and represent it in a more effective format. Collected data includes both binary and analog values. Binary data (e.g. chair

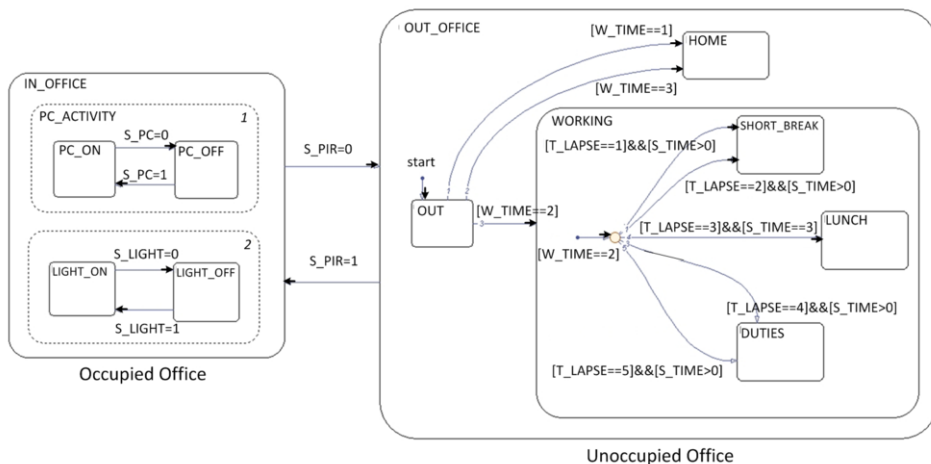

Figure 3. The events flow hierarchy of an event-driven model to discover user's activities in an office environment.

occupancy sensor) will generate a sparse data record. In our earlier research, it is shown that using Start-Time and Duration of activities would be an effective form of representation for binary sensory data.

3. Activity Recognition of an Office Worker

In order to identify ADW of an office worker, it is important to distinguish between the time the office is occupied and unoccupied. It is also important to distinguish if the office is unoccupied due to breaks/out-of-office duties, and the time that the office is unoccupied due to leaving at the end of the work day. This can include the time that the user spends on out of the office to perform duties such as teaching, meetings, etc. An event driven approach is applied to guide transitions, where events are used to indicate a certain scenario of a worker's activity.

The events flow of an office worker can be presented in a hierarchy diagram. Figure 3 shows the hierarchy of events flow for an individual office worker. In order to define the event of user's activity, the input, output and parent of an event are specified. Secondly, the events flow is determined based on a worker's ADW in the office and out of the office. The main event is separated into two separate events of IN OFFICE and OUT OF OFFICE.

Based on the information gathered from the occupancy sensor (PIR), the event will be determined. These two events hold many other events based on the conditions of other sensors.

Sensor conditions are used to control the event sequence in a transition within an event driven model. In addition to sensor conditions, three temporal variables are also defined. They are; *Time Lapse*, *Start Time* and *Working Time*. *Time Lapse* is defined as an interval of time where a worker is out of the office. It starts when the worker leaves the office and ends when the worker returns. A variable of *Start Time* is used to indicate when

Table 1. Temporal variable's values and ranges for activities recognition model.

Temporal Variable	Value/Range
Time Lapse	$T_LAPSE = \{ \text{Very_Short}=1, \text{Short}=2, \text{Medium}=3, \text{Long}=4, \text{Very_Long}=5 \}$
Start Time	$S_TIME = \begin{cases} \text{Early Morning}(EM); & \text{IF } 7.00 \text{ AM} < EM < 8.30 \text{ AM} \\ \text{Morning}(M); & \text{IF } 8.30 \text{ AM} < M < 10.30 \text{ AM} \\ \text{Late Morning}(LM); & \text{IF } 10.30 \text{ AM} < LM < 12.00 \text{ PM} \\ \text{Early Afternoon}(EA); & \text{IF } 12.00 \text{ PM} < EA < 13.00 \text{ PM} \\ \text{Afternoon}(A); & \text{IF } 13.00 \text{ PM} < A < 15.00 \text{ PM} \\ \text{Late Afternoon}(LA); & \text{IF } 15.00 \text{ PM} < LA < 17.00 \text{ PM} \\ \text{Evening}(E); & \text{IF } 17.00 \text{ PM} < E < 19.00 \text{ PM} \end{cases}$
Working Time	$W_TIME = \begin{cases} \text{Before Arrival}= 1; & \text{IF } TimePIR_1 > WT \\ \text{Working}= 2; & \text{IF } TimePIR_1 < WT < TimePIR_n \\ \text{After Departure}= 3; & \text{IF } TimePIR_n < WT \end{cases}$ <p>Where, $TimePIR_i$ is the time of PIR's sensor is activated, and $i=1,2,\dots,n$.</p>

the worker leaves the office and returns based on time partitions (e.g. morning, afternoon, evening). The variable of Working Time is divided into three categories i.e. before start work, working and finish work. It indicates the period of time that an individual worker arrives and departs from the office.

Since a worker activity and the real time can be recorded by an intelligent office environment system, the absolute time of temporal variables can be computed using statistical algorithms based on office occupancy signals from the PIR sensor. A worker's ADW patterns are not fixed and they may vary on different days of a week depending on the nature of the work. The values of time lapse are constructed using the semi-interquartile range [19]. Based on our previous work [20], start time is divided into 7 partitions, working time is divided into 3 partitions and time lapse is divided into 5 partitions. A working time is defined as the interval between the arrival and departure times of the worker to the office. These times are detected by office occupancy recorded from a PIR sensor. The statistical algorithms provided the following data outputs for the temporal variables values as shown in Table 1.

A set of heuristic If-Then rules is applied to control the transition of events for event-driven activity recognition. An algorithm consists of the rules to determine the event's transition of worker's activities based on sensory signals. The sensory signals and temporal variables are used as the antecedence part of the rules, where the consequence part can be expressed as a sequence pattern of X as shown below with possible values listed in Table 2.

Table 2. The categories of user's activities.

Category	Activity
HOME	At home or going home
DUTIES	Out of office duties
LUNCH	Lunch
SHORT_BREAK	Short break
PC_OFF	Not use computer
PC_ON	Using Computer

$$X = \underbrace{\{HOME, DUTIES, SHORT_BREAK, LUNCH, PC_OFF, PC_ON\}}_{\text{Listed in Table 2}}$$

Linguistic rules are listed below:

1. **IF** $S_PIR_i = 0$ **AND** ($W_TIME = 1$ **OR** $W_TIME = 3$) **THEN** $X = HOME$.
2. **IF** $S_PIR_i = 0$ **AND** $W_TIME = 2$ **AND** $S_TIME > 0$ **AND** ($(T_LAPSE = 1$ **OR** $T_LAPSE = 2)$) **THEN** $X = DUTIES$.
3. **IF** $S_PIR_i = 0$ **AND** $W_TIME = 2$ **AND** $S_TIME > 0$ **AND** ($(T_LAPSE = 1$ **OR** $T_LAPSE = 2)$) **THEN** $X = DUTIES$.
4. **IF** $S_PIR_i = 0$ **AND** $W_TIME = 2$ **AND** $T_LAPSE = 3$ **AND** $S_TIME = 3$ **THEN** $X = LUNCH$
5. **IF** $S_PIR_i = 0$ **AND** $W_TIME = 2$ **AND** $S_TIME > 0$ **AND** ($(T_LAPSE = 1$ **OR** $T_LAPSE = 2)$) **THEN** $X = SHORT_BREAK$.
6. **IF** $S_PC_i = 1$ **THEN** $X = PC_ON$.
7. **IF** $S_PC_i = 0$ **THEN** $X = PC_OFF$.
8. **IF** $S_Light_i = 1$ **THEN** $X = LIGHT_ON$.
9. **IF** $S_Light_i = 0$ **THEN** $X = LIGHT_OFF$.

where S_PIR_i represents office occupancy from PIR sensor, S_Light_i represents light sensor and S_PC_i represents computer sensor. Subscript i denoted the time in the sequence of data set. A temporal variable is denoted such as W_TIME for working time, S_TIME for start time and T_LAPSE for time lapse.

A time lapse variable is used to determine events when an office is not occupied. This is represented as *DUTIES* for out of office duties, *SHORT_BREAK* for a short break and *LUNCH* for lunch period. For example, if $S_PIR = 0$, then OUT state is activated. The destination of transition is determined by $W_TIME = 1$, $W_TIME = 2$ and $W_TIME = 3$. If $W_TIME = 2$ is true, the transition to WORKING state is valid. In this state, the destinations of transitions are determined by T_LAPSE . If $T_LAPSE = 2$ and $S_TIME = 3$ is true, the transition is to LUNCH. The LUNCH state will be active until $S_PIR = 1$, where a worker has entered back to the office. Temporal variables are used to determine whether the worker has gone home, having a short break, on lunch break or is performing out of duties.

4. Implementation

The developed data collection system was installed in academic offices at a university campus. To test and validate our approach to recognise an office worker's activities, collected data from our experimental offices are initially annotated [21, 22]. Annotation of the collected data will help us to understand the the relationship between the raw data and the actual activity. The rules generated from the sensory data are compared against the actual activity.

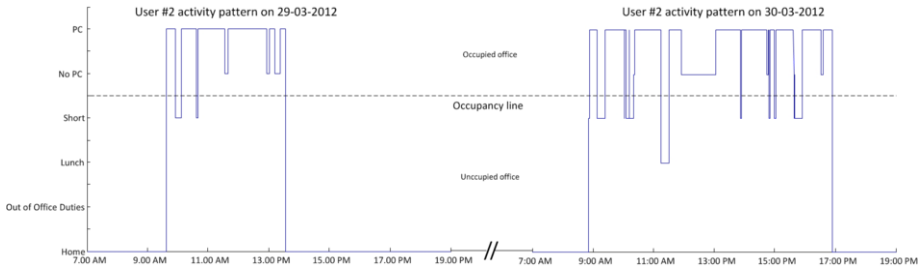

Figure 4. The activities patterns of an office user for two days.

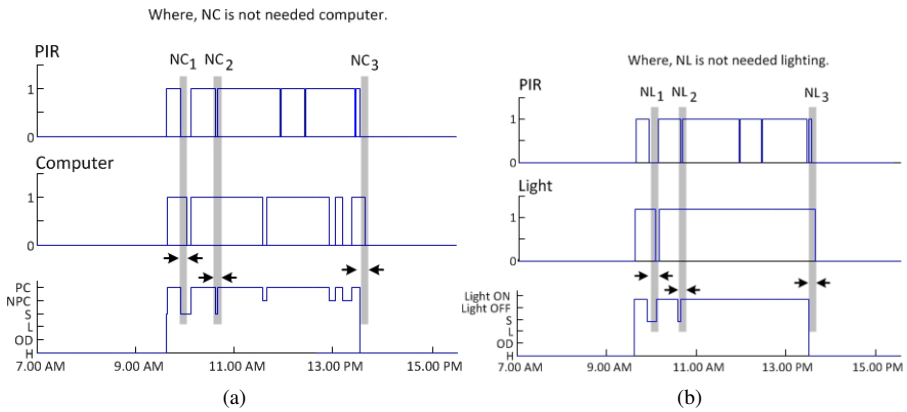

Figure 5. The samples of patterns for a) user’s activity, office occupancy and computer usage b) user’s activity, office occupancy and lighting usage.

Sensor based activity recognition using an event-driven and If-Then rules approach have demonstrated success in tracking the activities of a worker during working days. Figure 4 shows the activity patterns of a user for two different days. The dashed line is used to divide occupancy into two parts: the occupied office part and unoccupied office part. The worker clearly has different patterns on different days. Based on the results, it can be concluded that our activity recognition system is able to discover more patterns for a worker’s activities such as short break, lunch and out of office duties.

Output of this model can be used to describe a user’s profile and pattern of computer usage. Comparing the PC activities with the recognition signal, it is possible to identify periods when the PC could have been switched off. With an accuracy of 91%, the recognition model has identified the PC activities. However, the accuracy will be even better if the recognition signal is compared with PIR signal. This could be upto 99% accuracy.

Hence the proposed methods can recognise a user’s activity and computer use pattern from sensory data such as PIR and PC. Figure 5-a shows the patterns comparing between occupancy, computer usage and a user’s activity. The model of activity recognition can be used to discover a worker’s activities and describe a pattern of lighting or radiator usage by replacing the PC’s sensor with light sensor or heater temperature sensor as the input of the model. For example, Figure 5-b compares the patterns between occupancy, lighting usage and a user’s activity.

Table 3. The estimation of a user's power consumption of computer and lighting in an office for a day.

	Computer Power Usage				Lighting Power Usage			
	Total/day	NC_1	NC_2	NC_3	Total/day	NL_1	NL_2	NL_3
Use								
office(hour)	3.57	0.12	0.06	0.12	3.97	0.18	0.06	0.11
Power used(KWh)	1.2	0.04	0.02	0.04	0.38	0.02	0.06	0.01
Unnecessary	0.1 KWh				0.08 KWh			
Information:	Computer = 300 Watt							
	Monitor=30 Watt							
	Lighting= 24 Watt \times 4 units							

Further investigations are conducted to identify a worker's activity and pattern of power usage. Detailed investigation of results in Figure 5 found that, after a user leaves the office, the computer and lighting are still powered on for around five to fifteen minutes. In Figure 5, the trace lines show the unnecessary operation of computer and lighting. As can be seen from the figure; NC_1 , NC_2 and NC_3 are unnecessary operations of computer, while NL_1 , NL_2 and NL_3 are unnecessary operations of lighting detected when a user leaves the office. Table 3 provides the results of power consumption measurements based on graphs in Figure 5. The results of the estimation measurements on computer power usage for a day is 1.20 KWh, and the power consumption of computer that was identified as unnecessary reached 0.10 KWh. The lighting power usage for a day is 0.38 KWh, and the power consumption of lighting that was identified as unnecessary reached 0.08 KWh. Therefore, in the future the activity recognition can be integrated with an environmental controller system to react automatically and turn on computer and lighting based on based on user needs.

5. Conclusions

Computational intelligence and pervasive sensing technology offers opportunities to design ambient intelligence for office environments. To optimise the energy consumption of computer and lighting in the office, ADW of an office worker must be identified from start to finish. The activity recognition using an event-driven model and If-Then rules has the capability to identify the activity of an office worker whether user's activities are in the office or out of the office during a typical working day. With this capability, a user activity can be tracked and classified into six categories such as use PC/lighting, not use PC/lighting, short break, lunch break, out of office duties and home. The experimental results showed that the proposed activity recognition models are able to identify six categories of user's activity with accuracy of more than 90%. Usually sensors can detect a worker's movement in the observation area only, while our activity recognition system can detect and classify activities of a worker, whether she/he in office or out of office. The experimental results show that the proposed model has the capability to improve monitoring and tracking the ADW in office environment.

References

- [1] A. Berl and H. de Meer. An energy consumption model for virtualized office environments. *Future Generation Computer Systems*, 27(8):1047–1055, 2011.
- [2] K. Steemers and S. Manchanda. Energy efficient design and occupant well-being: Case studies in the UK and India. *Building and Environment*, 45(2):270–278, 2010.
- [3] L. Huang, H. Chang, C. Chen, and C. Kuo. A zigbee-based monitoring and protection system for building electrical safety. *Energy and Buildings*, 43(6):1418–1426, 2011.
- [4] B. P. Haynes. The impact of office comfort on productivity. *Journal of facilities management*, 6(1):51–37, 2008.
- [5] W. Chung and Y. V. Hui. A study of energy efficiency of private office buildings in Hong Kong. *Energy and Buildings*, 41(6):696–701, 2009.
- [6] S. Ari, P. Wilcoxon, H.E. Khalifa, J.F. Dannenhoffer, and C. Isik. A practical approach to individual thermal comfort and energy optimization problem. In *Annual Meeting of the North American on Fuzzy Information Processing Society (NAFIPS)*, pages 1–6, may 2008.
- [7] D. Jenkins, Y. Liu, and A. D. Peacock. Climatic and internal factors affecting future UK office heating and cooling energy consumptions. *Energy and Buildings*, 40(5):874–81, 2008.
- [8] P. M. Bluyssen, M. Aries, and P. van Dommelen. Comfort of workers in office buildings: The european hope project. *Building and Environment*, 46(1):280–288, 2011.
- [9] Johnny K. W. Wong and Heng Li. Application of the analytic hierarchy process (AHP) in multi-criteria analysis of the selection of intelligent building systems. *Building and Environment*, 43(1):108–125, 2008.
- [10] H. Doukas, C. Nychtis, and J. Psarras. Assessing energy-saving measures in buildings through an intelligent decision support model. *Building and Environment*, 44(2):290–298, 2009.
- [11] E. Kim, S. Helal, and D. Cook. Human activity recognition and pattern discovery. *IEEE Pervasive Computing*, 9(1):48–53, 2010.
- [12] V. Tabak and B. de Vries. Methods for the prediction of intermediate activities by office occupants. *Building and Environment*, 45(6):1366–1372, 2010.
- [13] X. Hong and C. D. Nugent. Partitioning time series sensor data for activity recognition. In *Proc. of the 9th International Conference on Information Technology and Applications in Biomedicine*, pages 1–4, 2009.
- [14] S. Chernbumroong, S. Cang, A. Atkins, and H. Yu. Elderly activities recognition and classification for applications in assisted living. *Expert Systems with Applications*, 40(5):1662–1674, 2013.
- [15] A. H. Shabani, D. A. Clausi, and J. S. Zelek. Evaluation of local spatio-temporal salient feature detectors for human action recognition. In *Proc. of 2012 Ninth Conference on Computer and Robot Vision (CRV)*, pages 468–475, 2012.
- [16] F. J. Ordonez, J. A. Iglesias, P. Toledo, A. Ledezma, and A. Sanchis. Online activity recognition using evolving classifiers. *Expert Systems with Applications*, 40(4):1248–1255, 2013.
- [17] I. H. Witten and E. Frank. Data mining: Practical machine learning tools and techniques. *Morgan kaufmann Pub.*, 2005.
- [18] M. J. Akhlaghinia, A. Lotfi, C. Langensiepen, and N. Sherkat. Occupant behaviour prediction in ambient intelligence computing environment. *International Journal of Uncertain Systems*, 2(2), 2008.
- [19] T. Martin, B. Majeed, Beum-Seuk Lee, and N. Clarke. Fuzzy ambient intelligence for next generation telecare. In *Proc. of 2006 IEEE International Conference on Fuzzy Systems*, pages 894–901, 2006.
- [20] S. Puteh, C. Langensiepen, and A. Lotfi. Fuzzy ambient intelligence for intelligent office environments. In *Proc. of 2012 IEEE International Conference on Fuzzy Systems*, pages 1–6, 2012.
- [21] A. Avci, S. Bosch, M. Marin-Perianu, R. Marin-Perianu, and P. Havinga. Activity recognition using inertial sensing for healthcare, wellbeing and sports applications: A survey. In *Proc. of the 23rd International Conference on Architecture of Computing Systems (ARCS)*, pages 1–10, 2010.
- [22] G. S. Chambers, S. Venkatesh, G. A. W. West, and H. H. Bui. Hierarchical recognition of intentional human gestures for sports video annotation. In *Proc. of the 16th International Conference on Pattern Recognition*, volume 2, pages 1082–1085 vol.2, 2002.

Mobile Monitoring System for Elder People Healthcare and AAL

Petr SUBA^{a,1} and Petr TUCNIK^a

^a *Department of Information Technologies, Faculty of Informatics and Management, University of Hradec Kralove, Czech Republic*

Abstract. The mobile monitoring system is intended for elder people capable of independent living on their own, requiring only minimum assistance, but suffering from minor health problems which require constant monitoring. The system should be able to detect especially life-threatening situations like heart failure, respiratory problems or fall detection, etc. which requires quick response from medical staff, but may be easily failed to notice if not under continuous observation. Our aim is to create cost-effective portable monitoring system based on smart phone hardware equipment. Reliable recognition of critical situations is the main purpose of the proposed system while the precise diagnosis is left to trained medical professionals and specialized equipment. System is combining input data of several sensors at the same time which results in more reliable functioning. This text is focused primarily on use of one of sensors used in the system - accelerometer sensor.

Keywords. Mobile sensors, ambient assisted living, homecare, healthcare, and accelerometer.

Introduction

Care for elder people is gradually increasing in importance, due to the recent demographical development. At the same time, public social services are expected to provide wide range of services - with maximum financial effectiveness due to the limited budgets - to number of clients increasing in correlating trend. This leads to search for cost-effective and reliable technical solutions.

Our goal is to design cost-effective health monitoring portable (mobile) system for elder people who are capable of independent living on their own, requiring only minimum assistance, but suffering from minor health problems which require constant monitoring. The system is designed to be able detect especially life-threatening situations like heart failure or respiratory problems, fall detection, etc. which requires quick response from medical staff, but may be easily failed to notice if not under continuous observation.

In any case, intended purpose of the system is not to provide substitution for ICU equipment or specialized diagnostic equipment. But these systems usually require presence of the patient (client) in bed, resulting in lower quality of life for people otherwise capable of taking care of themselves. This is especially important for elder people.

¹ Corresponding Author: Faculty of Informatics and Management, University of Hradec Kralove, Rokitanského 62, Hradec Králové 50003, Czech Republic; Email: petr.suba@uhk.cz

The proposed system described here is primarily intended for use at workplaces with services for elder people needs like retirement homes or medical institutions for long-term healthcare. Possibly even hospital departments where continuous observation of patients is required but it is not necessary for the patient to remain in bed all the time. Other possible application would be homecare – in this case, the system is modified for use in home environments, at the assumption family member (or anyone else) will be present in order to provide assistance when dangerous situation occurs.

Take under consideration that described system is still in development.

1. State of the Art

Intelligent environments have wide range of applications. Important distinction is in intended use. Main usage in typical commercial solutions (e.g. while implementing intelligent homes or offices) lies in increased comfort, security, entertainment and cost-effective maintenance (usually considering ecological, “green” approaches) while applications in public services are primarily motivated to provide assistance and care to its inhabitants or users.

It was already mentioned that proposed system is intended to be used at workplaces with services for fulfilling elder people needs like retirement homes or medical institutions. The improvement in quality of life for elderly clients can be significant, provided some elementary aspects of system’s functioning are taken into account, also see [1] which shares our perspective.

First of all, it is an assistance that is often expected. In this aspect, the systems for homecare and ambient assisted living applications are different from standard intelligent environments, since more interaction with users is not considered to be interruptive or unwelcome.

Secondly, there is a great importance of reliable protection of sensitive information of personal nature which the monitoring system works with all the time [2].

The third very important - and also often omitted - aspect is the respect for the privacy. This is well described by Ziefle et al. in [3]. Although the person is under continuous surveillance, there is no need to share all data gathered all the time. According to Ziefle [3], it is worth mentioning that the most disliked technology for home monitoring are camera-based systems. Also the study done by Kanis et al. [4] clearly shows some technical solutions like video or audio recordings are considered to be too invasive in regard of privacy by elder people. Rothenpieler [2] in this context comes to this conclusion: *„The collected data about the user has to be minimized to the amount which is required to effectively fulfill the monitoring task. (...) The data further should be kept anonymous as long as possible and should only contain references to the originating household if this information is needed, e.g. by an ambulance.”*

Other issue that also has to be considered is social aspect of continuous monitoring which could have negative influence on user’s social life, see [5]: *“...this (monitoring) may also increase the user’s social isolation if his friends refuse to enter the bugged apartment.”* For this reason, Rothenpieler suggests simple technical solution of easily accessible on/off switch and a status indicator in combination with global privacy switch, e.g. located at the entrance door.

The similar perspective to the proposed system offers Bekiaris et al. [5] with “REMOTE AAL” project, focused on remote health and social care for independent living of isolated elderly with chronic conditions. Another interesting project is

“AmIVital” project of Valero et al. [6]. Finally, an overview of studies to determine user requirements for in-home monitoring systems can be found in [7] which is useful for proper monitoring system design.

2. System Architecture

The system architecture is divided into several parts; the monitoring device itself and its components are shown at the Fig. 1. The main sources of collected information are shown on the left side of the Fig. 1. Sensors such as gyro sensor, accelerometer, GPS, compass or microphone are often already embedded as an integral part of smart phones. This creates suitable basis for construction of monitoring device.

Devices on the right side of the Fig. 1 are not part of the system at this moment. However, their incorporation is possible and will be most probably required in the future. Input of video cameras, motion detectors or floor sensors (list could be arbitrarily extended) may provide useful information when system tries to recognize health problems or detect fall of a client, etc. and there are already usable technical solutions available, well adjusted for the needs of this system. Since there is a lot of research already on-going in these areas, e.g. see work of Larizza [7], these possible extensions of the system will not be discussed here any further.

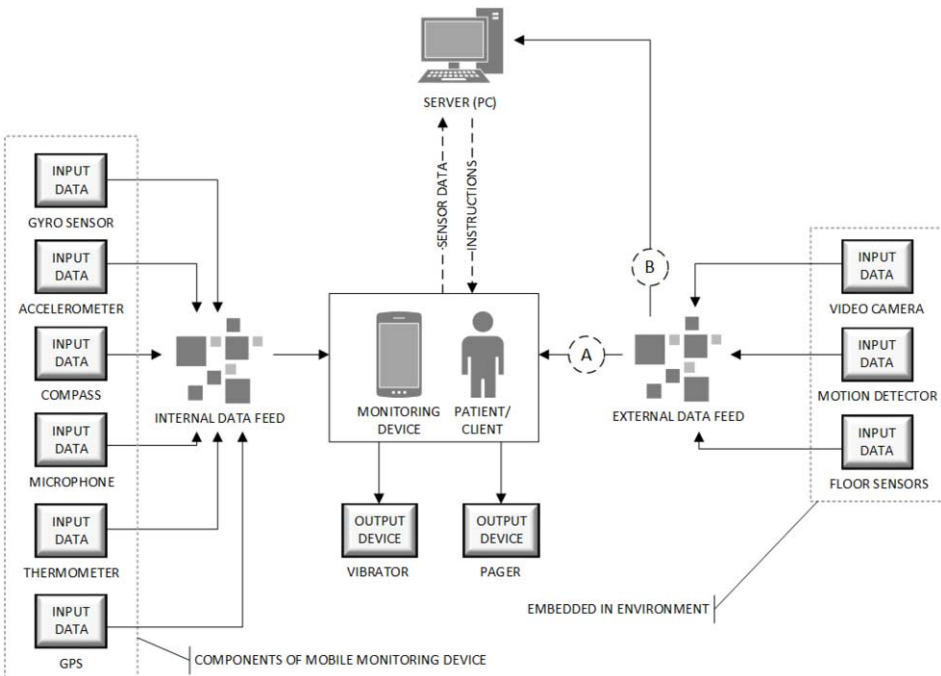

Figure 1. System components – sensors providing internal/external data flow

The main components and communication within the system are shown at the Fig. 2. The monitoring device (worn by user) transfers sensor data to server for further processing and analysis. Expert system is used for recognition of potentially dangerous situations and if such situation occurs, it sends notification to both medical staff and

doctor. In order to do so, expert system uses data from different sensors to validate classification of actual situation.

The medical staff is responsible for providing assistance, if needed, and is equipped with tablet containing overview of all patients and their (medical) status. This device contains also information about environment (layout, building plans, maps) as well as medical records of all patients currently in the care. Logs database is used for maintenance reasons and continuous updates on system's functioning are stored here (this is important especially when an error occurs or when optimizing system's performance).

The smart phone device used by doctor provides overview of each patient's health condition in periodic time intervals (it is not necessary to have continuous data feed). Doctor is able to send instructions regarding medication, examination etc. to the medical staff.

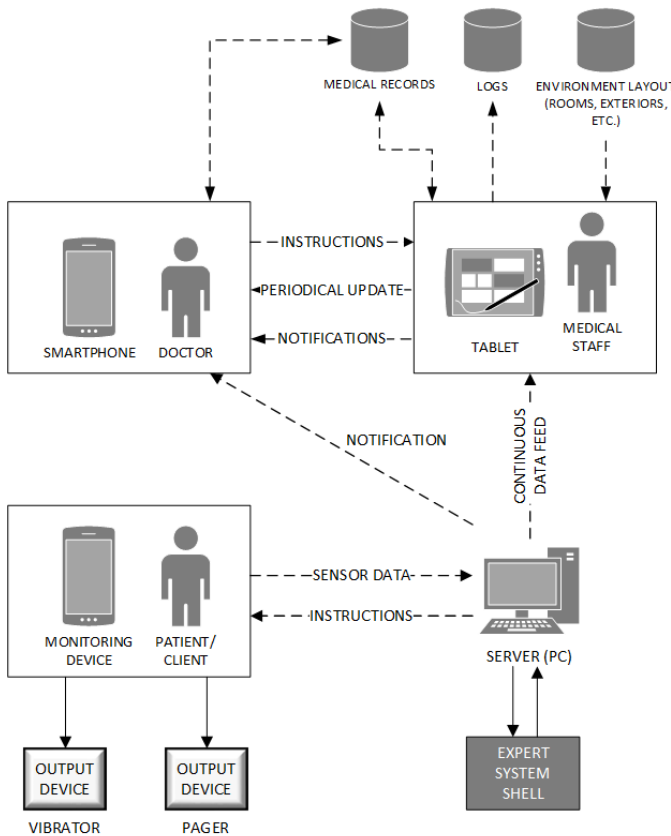

Figure 2. System components – data processing

The part of the system which would be discussed in more detail is the accelerometer sensor. Its purpose, in general, is to measure movement (in all three axes). Accelerometer usage for application in similar context is described by Matthews in both [8] and [9] (the latter is focused on accelerometer calibration), by Ravi [10], Chen and Khalil [11], Masse et al. [12], or Trost et al. [13]. These papers are generally

focused on activity recognition from accelerometer data. Important conclusion is mentioned by Trost et al. [13]: *“Studies employing multiple accelerometers to estimate physical activity energy expenditure report marginal improvements in explanatory power. These small improvements do not warrant the increased subject burden associated with wearing multiple accelerometers.”* Our system is employing only single accelerometer, which is in correspondence with mentioned study results.

3. Numerical Scanning of Physical Quantities

For the need of proposed system, it is important to scan following attributes:

- Immediate acceleration
- Position of the device towards tangential of Earth’s surface
- Position of the device towards magnetic poles
- Position of the device within geographical co-ordinates
- Noise level
- Temperature
- Humidity
- Light intensity
- Pressure

This list already takes into account possibilities offered by the category of selected hardware. Nonetheless, it may be useful to scan other physical attributes as well:

- Blood pressure
- Blood gas concentration
- Blood flow
- Lungs airflow rate
- Body surface temperature
- And others...

Scanning of above mentioned physical quantities is already well-explored area. Also, the selection of sensors available at the market is abundant. However, the proposed monitoring system is using preferentially a single monitoring device conception. For this reason, as long as it is possible, this conception will be respected which should result in a minimal encumbrance required of the monitored person to wear.

Each scanning of physical phenomena (in real-world cases) is flawed by certain level of scanning imprecision (i.e. due to wrong calibration of sensors) and by noise, especially in the case of continuous scanning. Both of these features results in error in obtained results. Noise filtering from continuously scanned data necessarily further magnifies error already present in the scanned data.

After first set of measurement, a significant level of background noise was present, depending on both the type of used sensor and the sampling frequency. A parallel scanning by referential sensor will be required for the precise measurement of noise level. This is a matter of future work since the detection of significant changes in signal

above the noise level is important at this stage of work, and quality of the signal is sufficient at this moment.

4. Choice of Sensors

The selection of scanning devices was deliberately limited to older smart phone with average level of equipment at the first phase of the research - Samsung Galaxy Ace GT-S5830 (2011).

The operating system Android in the last supported version v2.3.6 is installed on the device. The smart phone contains these sensors only:

- TAOS – proximity sensor.
- BMA220 – digital, triaxial acceleration sensor.
- MMC314X – triaxial magnetic sensor.

An accelerometer sensor was selected for the series of tests and evaluation of usability for the intended application in the research project. According to manufacturer’s documentation [14], this sensor is not suitable for use in life-sustaining or security sensitive systems (either is not this case since proposed system is intended for detection of life threatening situations). This does not necessarily pose a problem since the sensor output will be further analyzed and correlation with other sensor’s output data will be expected.

4.1. Key Features of the Sensor

According to manufacturer specifications, the sensor BMA220 has programmable functionality. It is possible to switch ranges from $\pm 2g$ to $\pm 16g$ in four steps. There is an on-chip integrated interrupt controller with interrupt signals for orientation recognition, any-motion detection, tap/double tap sensing, and low-g/high-g detection, see [14].

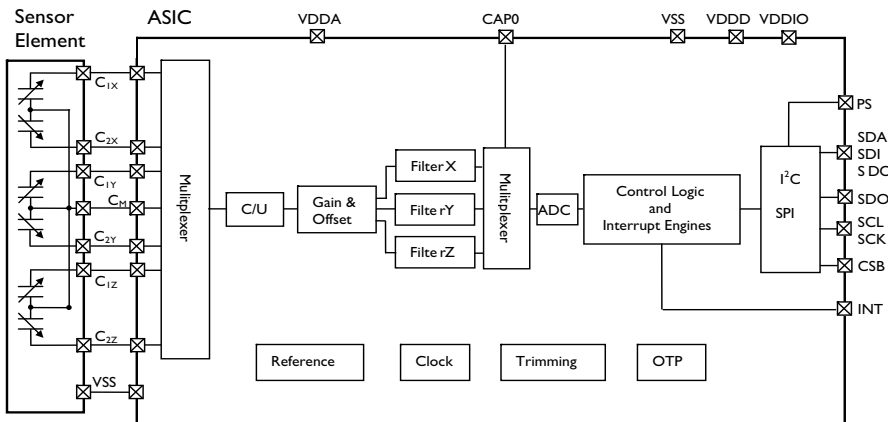

Figure 3. Block diagram BMA220, from [14].

The sensor BMA220 works in three power-consumption modes. Normal mode requires supply of current 250 μ A. In a low-power mode, the sensor consumes less than 10 μ A. In suspend mode, less than 1 μ A is consumed. Typical supply voltage is 1.8 V. Wake-Up time from sleep or suspend mode is 1.2 ms. The noise depends on used bandwidth. As it is known from the documentation[14], chosen sensor's typical noise is $2mg/\sqrt{Hz}$.

5. Structure and Type of Data

After the verification of functionality, a multiple series of tests were run to find optimal sampling frequency and was created suitable data format for representation. After this preparation phase, a multiple continual measurements of data in three basic scenarios were done. These scenarios are:

- A. 2 minutes while lying still on the floor
- B. 2 minutes while on the chest of sleeping person
- C. 2 minutes while standing and having conversation

Data were sampled with frequency of ten samples per second and stored in *.csv format on memory card. Along with accelerometer data, other data from different sensors, including GPS position and noise level, were stored as well. After the measurement, the data were transferred to PC for evaluation.

Table structure of the *.csv format allowed simple transfer to representation in a form of a chart. Data evaluation revealed unexpectedly high level of noise, present in all parts of measured data. Noise level is clearly seen in part of the chart representing the idle state (Fig. 4).

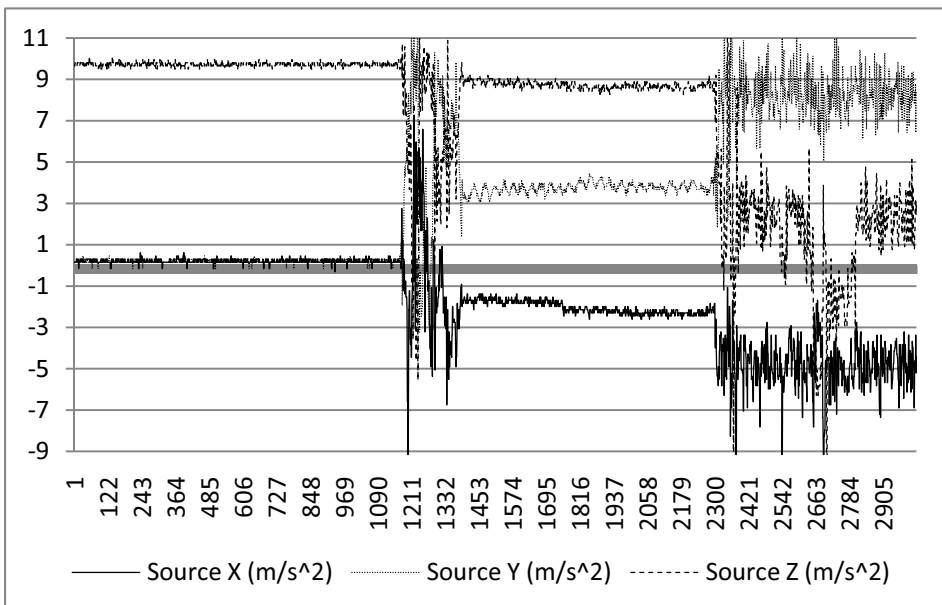

Figure 4. Shortened chart of received source data

Other negative phenomenon, observed during measurement, is low granularity of measured values. The sensor manufacturer specifies data register range of 64 values for each axis, see [14]. In measured data were perceived 141 of unique values. This is a result of automatic change of sensor range which is done at the level of operating system. The more precise measurement setting is intended for future work, because at this moment, the precision of received data is sufficient.

Final part of the recorded data, representing significant movement activity, holds minimal importance for further detailed analysis because while the monitored person is walking/running, there is usually no reason to set off the alarm. Although certain situations may be imagined when patient needs assistance and is moving at the same time, these situations are generally more easily identified by other sensors (like heart monitor, for example) and data from accelerometer may be used for confirmation purposes only.

The most important part of data for the further analysis was the part representing sleep. In spite of presence of the noise, distinct respiratory pattern was identified in the chart. This is very useful for further research and enabled further, more detailed analysis.

6. Data Processing

As was already mentioned, most attention was focused on the middle part of data representing (pretending) sleep. In the chart was recognized distinct respiratory activity.

Table 1: Example of recorded data

Source X (m/s ²)	Source Y (m/s ²)	Source Z (m/s ²)
0,1532	0,1532	9,6534
0,1532	0,1532	9,6534
0,1532	0,3065	9,8067
0,3065	0,1532	9,8067
0,3065	0,1532	9,6534
0,1532	0,3065	9,6534
0,3065	0,3065	9,6534

For further processing, it was necessary to implement noise filtration to clear measured data. Although hardware-assisted processing could be more efficient, a low-pass filtering method implemented in Matlab platform was selected. This choice was made because Matlab allows more accurate customization of filter implementation which is more useful for purposes of future research.

Used function was chosen instead of integrated filters in Matlab SPT for easy implementation in mobile device and of independent server streaming process. It offers only two samples delay for every stream of data, see [11] and [15]. Following algorithm describes process of application of low-pass filter used for processing and analysis of accelerometer data.

The first step is to determine cut-off frequency (f_c). Sampling frequency (f_s) is known as a number of samples in second. As it is outlined below, chosen cut-off frequency is 4Hz (empirically verified).

In the second step it is necessary to solve angular shape of cut-off frequency (O_c) in radians:

$$O_c = \frac{(2\pi f_c)}{f_s} \tag{1}$$

The next step is used for calculation of wave dependent β and γ values which are used in later steps:

$$\beta = 0,5 \left(\frac{1 - \left(\frac{\pi \sin(O_c)}{2 O_c} \right)}{1 + \left(\frac{\pi \sin(O_c)}{2 O_c} \right)} \right) \tag{2}$$

$$\gamma = (0,5\beta) \cos (O_c) \tag{3}$$

Now it is possible to calculate feed-forward weight coefficients:

$$a_0 = \frac{(0,5+\beta-\gamma)}{2} \tag{4}$$

$$a_1 = 0,5 + \beta - \gamma \tag{5}$$

$$a_2 = a_0 \tag{6}$$

And two feedback coefficients:

$$b_1 = -2\gamma \tag{7}$$

$$b_2 = 2\beta \tag{8}$$

In the following final step, it is possible to solve equation for each sample. Delay is two samples (as was mentioned above):

$$y_{(n)} = a_0x_{(n)} + a_1x_{(n-1)} + a_2x_{(n-2)} - b_1y_{(n-1)} - b_2y_{(n-2)} \tag{9}$$

Where used notation holds following meaning:

- $x_{(n)}$ second order low pass filter (for n-th sample in input signal)
- $y_{(n)}$ second order low pass filter (for n-th sample in output signal)

After filtering, graphical representation of original data was compared to data after filter application. Simple visual comparison is quite conclusive; at it can be seen at the Fig. 5. Selection of suitable cut-off frequency allows identification of respiratory pattern.

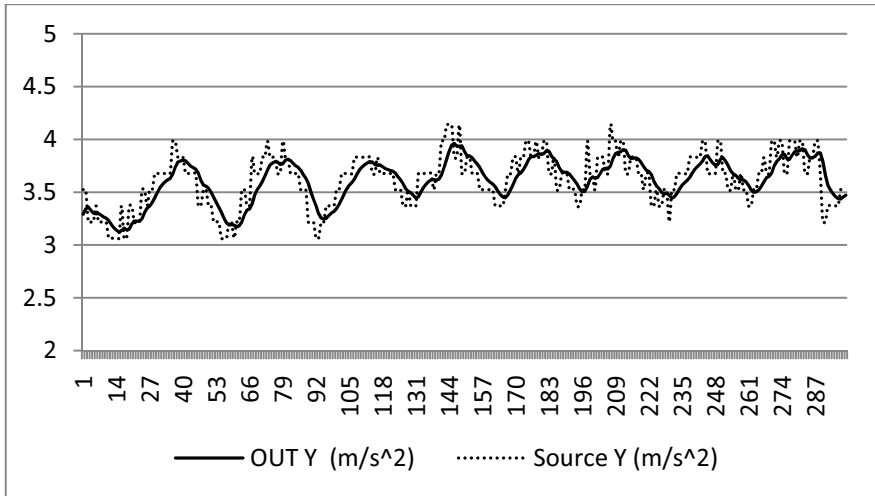

Figure 5. Low-pass filter function

Cut-off frequency was experimentally set to these values:

$$f_c = 0.4 f_s \quad (10)$$

Proper settings of cut-off frequency were crucial for quality of results, as was later obvious. With significantly lower setting of cut-off frequency, there was an oscillation, and higher setting would not provide sufficient filtration ratio. Cause of oscillation is obvious from the positive feedback used in filtering algorithm.

Experimentally, a second low-pass filter was applied to already once filtered data. Its effect was insignificant, even when control coefficients were changed. Shape of respiratory activity was closer to sinus curve shape, but chart shape was more distorted and number of local extremes remained the same. As a result, single application of low-pass filter is considered to be optimal for the given purpose.

For the further advancement in research, it would be convenient to transfer at least part of filtering process directly to the mobile device. However, the question of impact of this action on the transfer bandwidth remains open. Data before application of the filter are more suitable for size compression (there are less values present) and transfer. In future, only data necessary for processing inside the device, i.e. required by other software components inside the device, will be processed there. Remaining data will be transferred in source values in order to be processed on the server.

7. Vital Functions Detection

Although the analysis of measured data offered some optimistic results, cautious approach is still required at this point. For example, body movements while breathing are not the only vital function to be monitored. Under adverse conditions, misinterpreted data could result in fatal consequences. Therefore, as should be stressed, the single sensor data (accelerometer, in this case) could not be used separately as an unsupported source of information, but only in correlation with other sensor's

signals in order to maintain high rate of reliability of the whole system. The robust system could only be built upon several sensors' signals combined together, confirming mutually each other. On the other hand, there is no obstacle preventing one from building this individual sub-system as autonomous segment (module) which will result in modularity and this will be a positive feature. Such module is able to process and provide necessary data, concentrating related functionality at the one place.

The respiration is a periodical activity. It is necessary to detect changes in amplitude and frequency, according to following list, in order to categorize signal:

- Calm breathing – *eupnoe*
- Fast breathing – *tachypnoe, polypnoe*
- Slower breathing – *bradypnoe*
- Deep breathing – *hyperpnoe*
- Shallow breathing – *hypopnoe*
- Stopped breathing – *apnoe*

For fulfilling these requirements for proper recognition of listed ways of breathing, it is necessary to establish multi-state representation of attributes allowing identification of these states. So far, the system is able to correctly detect and recognize respiration.

8. Conclusion and Future Work

Research accomplished so far showed significant flaws in quality of measured data. This is the reason why the future effort will be focused on optimization of applications controlling individual sensors. It is necessary to perform parallel data collection from several devices and make comparison with referential device (i.e. medical devices with similar scanning purpose).

Preliminary tests on other devices, especially referential device LG Nexus 4, shows better data granularity and lower noise levels. On their basis, decision making will be more accurate and reliable. Also higher performance and better power efficiency of modern devices allow more computational operations to be done directly in monitoring device itself, saving transfer bandwidth as a result.

Acknowledgements

This work was supported by the project No. CZ.1.07/2.2.00/28.0327 Innovation and support of doctoral study program (INDOP), financed from EU and Czech Republic funds and by Specific Research Project “The use of smart mobile devices in life-saving applications” (2013).

References

- [1] R. Rogers, Y. Peres, W. Müller, Living longer independently – a healthcare interoperability perspective, *Elektrotechnik & Informationstechnik* 127/7–8 (2010), 206–211.
- [2] P. Rothenpieler, C. Becker, S. Fischer, Privacy Concerns in a Remote Monitoring and Social Networking Platform for Assisted Living, *Privacy and Identity 2010, IFIP AICT 352* (2010), 219-230.
- [3] M. Zieffle, S. Himmel, W. Wilkowska, When Your Living Space Knows What You Do - Acceptance of Medical Home Monitoring by Different Technologies, *Lecture Notes in Computer Science 7058* (2011), 607-624.
- [4] M. Kanis, S. Alizadeh, J. Groen, M. Khalili, S. Roberts, Ambient Monitoring from an Elderly-Centred Design Perspective: What, Who and How, *LNCS 7040* (2011), 330-334.
- [5] A. Bekiaris, A. Mourouzis, N. Maglaveras, The REMOTE AAL Project: Remote Health and Social Care for Independent Living of Isolated Elderly with Chronic Conditions, *Lecture Notes in Computer Science 6767* (2011), 131-140.
- [6] Z. Valero, G. Ibáñez, J. C. Naranjo, P. García, AmVital - Digital Personal Environment for Health and Well-Being, *LNICST 55* (2011), 160-167.
- [7] M. Larizza et al., Studies to Determine User Requirements Regarding In-Home Monitoring Systems, *Lecture Notes in Computer Science 7379* (2012), 139-150.
- [8] C. E. Matthews, B. E. Ainsworth, R. W. Thompson, D. R. Bassett, JR., Sources of variance in daily physical activity levels as measured by an accelerometer, *Medicine and Science in Sports and Exercise*, Vol. 34, No. 8 (2002), 1376-1381.
- [9] C. E. Matthews, Calibration of Accelerometer Output for Adults, *Medicine and Science in Sports and Exercise*, Vol. 37, No. 11 (Suppl.) (2005), S512-S522.
- [10] N. Ravi, N. Dandekar, P. Mysore, M. L. Littman, Activity Recognition from Accelerometer Data, *IAAI-05* (2005), 1541-1546.
- [11] L. Chen, I. Khalil, Activity Recognition: Approaches, Practices and Trends, *Activity Recognition in Pervasive Intelligent Environments*, Atlantis Press, Paris, 2011.
- [12] L. C. Masse et al., Data-reduction-supplement Comparison of Four Reduction Algorithms on Select Outcome Variables, *Medicine and Science in Sports and Exercise*, Vol. 37, No. 11 (Suppl.) (2005), S544-S544.
- [13] S. G. Trost, K. L. Mciver, R. R. Pate, Conducting Accelerometer-Based Activity Assessments in Field-Based Research, *Medicine and Science in Sports and Exercise*, Vol. 37, No. 11 (Suppl.) (2005), S531-S543.
- [14] Bosch Sensortec GmbH, BMA220 Data sheet, Document revision 1_15_082011, 2011 (technical documentation).
- [15] J. O. Smith, Introduction to digital filters with audio applications, available on-line (04.30.2013): ccrma.stanford.edu/~jos/filters/.

2nd International Workshop on Future Intelligent Educational Environments (WOFIEE 2013)

Juan Carlos Augusto (Middlesex University, United Kingdom)

Vic Callaghan (Essex University, United Kingdom)

Minjuan Wang (San Diego State University, USA)

This page intentionally left blank

Introduction to the Proceedings of WOFIEE'13

As the world moves steadily to become a knowledge-based economy, education and learning have never been more important. Technology is playing an increasingly crucial role in the delivery of education, which in turn is driving research into the search for ever better technological solutions. The age of intelligent environments is bringing such pedagogical advances as smart classrooms, intelligent campuses, immersive and mixed-reality learning, affective learning, mobile learning, intelligent learning clouds and personalised intelligent tutors to revolutionize current learning practices, and to challenge the traditional notion of a university or school.

Based on this context we launched the 1st International Workshop on *Future Intelligent Educational Environments* during IE'12 in Guanajuato (Mexico) and we decided to continue this event with the hope this will provide a forum where to discuss the current state-of-the-art, imagine solutions for current limitations and plan steps within our community which may help to achieve some of the required advances in this area. This event will serve as a forum for researchers and practitioners to discuss the latest intelligent technologies that can support the development of new educational technologies and environments around the world.

Central to this forum are enriched physical and virtual environments such as smart classrooms, virtual / mixed-reality environments, intelligent learning clouds or mobile and augmented-reality systems that can interact with students and teachers at a pedagogical level, so as to bring true innovations to education. We also include the systems that support the learning of practical skills, such as those typified by science and engineering laboratories that are critical to students. We also consider the wider campus infrastructure, which can also impact the cost and effectiveness of education. Examples include smart signage that can guide people around a campus or smart applications for timetabling or managing the environment of the teaching facilities. Education is increasingly global and the cultural dimension is a topic we consider important for this event. Finally, scientific research, engineering Innovation and business advancement are beneficiaries of good education and it's fitting that we are including a paper that considers how entrepreneurship for creating and commercialising future educational environments might be supported.

An additional notable development we are pleased to report is the creation of the *Transactions on Future Intelligent Educational Environments (TOFIEE)*¹ which will provide a rigorous academic forum where significant achievements will be published for global access.

As a final note, we wish to express our sincere thanks to the WOFIEE'13 Program Committee for their thorough reviews and strong support. We will also like

¹<http://icst.org/future-intelligent-educational-environments>

to acknowledge our gratitude to the authors who submitted their contributions and to those who will be there during the event to enrich the event with their opinions. We are looking forward to meeting you all at this workshop which will allow us to meet and build a strong community dedicated to introducing exciting innovations to education.

Juan C. Augusto, Vic Callaghan, Minjuan Wang
Co-chairs WOFIEE'13

A Mobile App for Adaptive Test in Intelligent Tutoring System Based on Competences

Miguel BADARACCO ^{a, 1}, Jun LIU ^{b, 2}, and Luis MARTINEZ ^{c, 3}

^aNational University of Formosa. Faculty of Economics and Business Administration.
Formosa, Rep. Argentina

^bSchool of Computing and Mathematics, University of Ulster, Newtownabbey BT37
0QB, Northern Ireland, UK

^cUniversity of Jaén Spain. Department of Computer Science, Campus Las Lagunillas,
s/n, E-23071 Jaén, Spain

Abstract. An Intelligent Tutor System (ITS) aims to customize teaching processes dynamically according to student's profile and activities by means of artificial intelligence techniques. The use of Competency based Education as pedagogical model has developed the ITS based on Competences (ITS-C). The architecture of an ITS-C uses a modular structure that optimizes the computational requirements for its implementation. Such modular architecture facilitates its use with ubiquitous devices. Therefore ITS-C or several of its processes may be ubiquitously offered to teachers and students. In this contribution a mobile app for adaptive test in ITS-C is introduced.

Keywords: Intelligent Tutoring Systems, Competency Based Education, Mobile Learning, Computerized Adaptive Tests.

Introduction

An ITS provides direct customized instruction or feedback to students in their learning processes by means of Artificial Intelligence (AI) techniques, being mainly applied to knowledge representation, managing an instruction strategy as an expert both in the teaching and pedagogical issues in order to diagnose properly the student learning status at any time. To fulfill its objective, an ITS is organized by an architecture composed by a domain model (what is taught?), student model (who is taught?), diagnosis of the student [1], instructional model (how is it taught?) [2] and the interface (man-machine interaction) [1], [3] (see Figure 1).

In [4] is presented an architecture for ITS based on Competency-based Education (CBE), which is characterized by a modular structure to represent the domain model and the student model. The updating process (student's diagnosis) based on Computerized Adaptive Test (M-CAT) [5] is an important module that is used during the student's learning process in which it is necessary to choose suitable items, modeling experts' knowledge regarding the usefulness of items. These features allow

¹ Tel.: +54 03717 451702; e-mail: itfor@arnet.com.ar

² Tel.: +44 28 90368919; e-mail: j.liu@ulster.ac.uk

³ Tel.: +34 953 211902; Fax: +34 953 212472; e-mail: luis.martinez@ujaen.es

optimizing performance and computational requirements of this module during its implementation. Therefore, due to the fact that adaptive tests during the learning process are common and frequent, it seems a potential process to be carried out in an ubiquitous way by means of mobile devices.

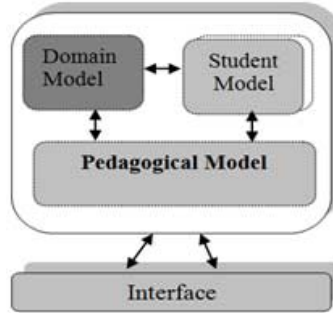

Figure 1. Generic architecture of ITS

This contribution presents an application developed on a mobile platform (Android) that allows deploying the architecture of an ITS's-C and implementing the diagnosis by Computerized Adaptive Tests of modular and distributed way using tablets and smartphones.

The paper is organized as follows; Section 2 reviews the ITS-C architecture and structure. Section 3 presents a Fuzzy Computerized Adaptive Tests for mobile devices (FM-CAT), its architecture and functionality. Finally some concluding remarks are pointed out.

1. Intelligent Tutoring Systems Based on Competency-based Education. Architecture and Diagnosis Process

An ITS-C extends ITS by linking the latter and the pedagogical model based on Competency-based Education (CBE) using the architecture showed in Figure 2 [4]. The domain model, student model are reviewed and then a further detailed revision of the diagnosis of an ITS-C is presented to facilitate the understanding of the proposal introduced in section 3.

1.1 Domain Model of ITS-C

The representation of the *domain model* in an ITS-C is based on the descriptors utilized in CBE [4] that reflect good professional practices to guide the development of the competency associated with an occupational role or profile [6], [7], [8]. Such a set of descriptors are:

- *Competency unit (cu)*: It is a main function that describes and groups the different activities concerning the role or profile chosen.

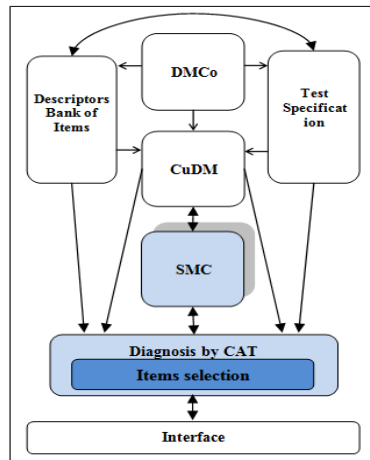

Figure 2. ITS-C Architecture

- *Competency element (ce)*: It is the disaggregation of a main function (*cu*) that aims to specify some critical activities. A function (*cu*) can be specified by one or more competency elements (*ce*), according to its complexity or variety.
- *Evidence of performance (evd)*: It checks if a process is performed according to best practices.
- *Evidence of product (evp)*: It is a descriptor of tangible evidence in the results level, when the best practices have been used.
- *Evidence of knowledge (evk)*: It is a descriptor about scientific-technologic knowledge that allows the user understands, reflects and justifies competent performance.

Therefore the *domain model* contains the expert's competences profile about a knowledge domain, hence for an ITS-C it will consist of four components briefly detailed below, further description see [4]:

- A domain model of competency (DMCo)*: It is represented by a semantic network whose nodes are competence units (*cu*), competence elements (*ce*), descriptors (*evd*, *evp*, *evk*) and their relations.
- A curriculum domain model (CuDM)*: It deploys the DMCo according to a teaching strategy that defines the competences associated to a professional profile to perform a training proposal in different situations. The CuDM based on the CBE takes a modular structure, in which each module (M_i) contains competency elements (*ce*) belonging to the DMCo.
- A set of descriptors*: The descriptors associated with the *ce* of the didactic modules are *evd*, *evp*, and *evk*, that belong to a bank of items.
- Test specifications*: They are provided by the teachers and associated with the diagnosis process considering the scope of application and the rules that the system should follow to propose adaptive tests according to the student's necessities of learning.

1.2 Student Model of ITS-C

In an ITS-C the *student model of competence (SMC)* stores student’s information, whose data are updated through a diagnosis process. For the representation of the student’s knowledge and learning process, the SMC uses an overlay model in the semantic network of the CuDM [9].

In such a semantic network the nodes *evp*, *evd* and *evk* store a probability distribution $P(\theta_{evp} = k | \vec{u}_i)$, $P(\theta_{evd} = k | \vec{u}_i)$, and $P(\theta_{evk} = k | \vec{u}_i)$ regarding the student’s level of competency *k* in the corresponding node, *k* can take values from 1 to the maximum number of level of competency on which the student is evaluated. Being θ the student’s level of technical-scientific knowledge about a descriptor for a response pattern \vec{u}_i obtained from the responses provided by the student in the test *T* (See Figure 3) during the diagnosis process.

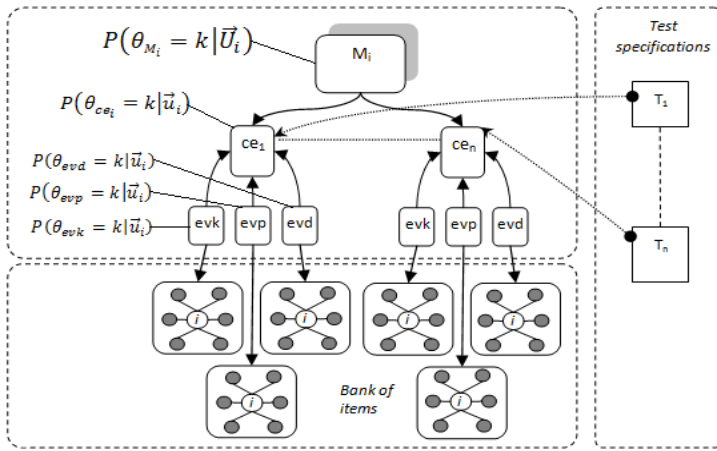

Figure 3. Module of Student Model of Competence

1.3 Diagnosis for ITS-C based on CAT

The diagnosis process estimates and updates the level of competency achieved by the student in the nodes of the SMC. To carry out the diagnosis of an ITS-C, it was adapted and extended the Computerized Adaptive Test (CAT) based on the Item Response Theory (IRT) [10]; [9]. In CAT systems the relationship between student outcomes in the test and its response to a certain item can be described by a monotone increasing function called the Item Characteristic Curve (ICC). The ICC of an ITS-C coincides with the correct response option of the characteristic curve of option (CCO). Its main components are:

- *A response model associated to the items*: It describes the student’s expected performance according to his/her estimated knowledge. An ITS-C uses a *discrete* and *non-parametric* response model based on the Item Response Theory (IRT) [11] able to evaluate multiple choice answers [10].
- *Bank of Items*: Each item I_i is associated to its descriptors (evd, evp or evk) and each option of I_i corresponds to a characteristic curve of option (CCO) obtained by a calibration process based on the Ramsay algorithm [12]. Each

CCO is represented by a probability distribution, $P(\vec{u}_i|\theta_0)$, where each component represents the probability that the student selects the response pattern \vec{u}_i , given her level of competence θ .

To develop a test the teachers must provide *test specifications* considering the scope of application and the student’s necessities of learning, namely:

- i) *Initial level of Knowledge*: The initial knowledge estimation is crucial because determines the length of the CAT for each student. It may be estimated by using different models based on previous information.
- ii) *Criterion for selecting descriptor (evp, evd or evk)*: The algorithm selects the descriptor that has the level of knowledge associated with lower probability [10]; [9]:

$$\min(\theta_{ev}) = \min(MAP(P(\theta_{ev}|\vec{u}_n))) \tag{1}$$

- iii) *Criterion for selecting items*: The adaptive CAT mechanism uses different methods to select the items for the test, a common method is the maximum information [13]; [10] that selects the item which maximizes the information in the provisional distribution of student’s knowledge. The information function for the item, I_j , is calculated as follows:

$$PI_j(\theta_i) = \frac{(P'_j(\theta_i))^2}{P_j(\theta_i)(1 - P_j(\theta_i))} \tag{2}$$

Being θ_i the knowledge level of the student i , $P_j(\theta_i)$ the value of the CCO for the student’s level, and $P'_j(\theta_i)$ the function derived from the CCO at that point. Other selection criteria were proposed in [13]; [10].

In [9] the item selection process uses experts’ knowledge, linguistically modeled, to characterize the usefulness of an item. Whereby the selected item is the maximum usefulness $\max(X_i^k)$.

- iv) *Stop criterion*: The test should stop when the student achieves a level of knowledge fixed a priori, though there are other criteria.

During the management of a test, the student's knowledge is estimated every time that he/she answers a question, by updating the student's knowledge distribution [13], as:

$$P(\theta_{ev}|\vec{u}_1, \dots, \vec{u}_i) = \begin{cases} |P(\theta_{ev}|\vec{u}_1, \dots, \vec{u}_{i-1})P(\vec{u}_i|\theta_o)| & \text{if } Q_i \text{ assesses } evd_j, \\ evk_j \text{ or } evp_j. & \\ P(\theta_{ev}|\vec{u}_1, \dots, \vec{u}_{i-1}) & \text{in other case.} \end{cases} \tag{3}$$

Being $P(\theta_{ev}|\vec{u}_1, \dots, \vec{u}_{i-1})$ the a priori student’s knowledge estimation on *evd, evp* or *evk*, and $P(\vec{u}_i|\theta_o)$ the CCO for the option of the response pattern.

After the updating process the system estimates the level corresponding to the distribution by using one out of two choices introduced in the CAT [13]; [10]:

- i) *Expectation a posteriori (EAP)*:

$$\theta_{ev} = EAP(P(\theta_{ev}|\vec{u}_n)) = \sum_{k=1}^n kP(\theta_{ev} = k|\vec{u}_n). \tag{4}$$

Being k the knowledge level.

ii) *Maximum a posteriori (MAP)*:

$$\theta_{ev} = MAP(P(\theta_{ev}|\vec{u}_n)) = \max P(\theta_{ev} = k|\vec{u}_n) \quad (5)$$

The competency level θ_{ce} is computed as:

$$\theta_{ce} = |k_1P(\theta_{evd} = k_1|\vec{u}_n) + k_2P(\theta_{evp} = k_2|\vec{u}_n) + k_3P(\theta_{evk} = k_3|\vec{u}_n)|, \quad (6)$$

being $P(\theta_{evd} = k_1|\vec{u}_n)$, $P(\theta_{evp} = k_2|\vec{u}_n)$ and $P(\theta_{evk} = k_3|\vec{u}_n)$ the probability regarding the descriptors evp , evd and evk and k_1 , k_2 and k_3 the competency levels respectively.

The competency level θ_M for the node M is computed by using the values of the nodes ce .

$$\theta_M = \sum_{j=1}^n |k_jP(\theta_{ce_j} = k_j|\vec{u}_n)|, \quad (7)$$

where $P(\theta_{ce_j} = k_j|\vec{u}_n)$ is the probability regarding the node ce_j and the competency level, k_j .

As it was pointed out in subsection 1.2, for the representation of the student's knowledge and learning process, the SMC uses an overlay model in the semantic network of the CuDM [9] whose structure is organized modularly, whereby an ITS-C might implement a competency domain gradually assimilating each module as "learning capsules". In 1.3 was discussed the diagnosis based on CAT which improves the efficiency, adaptability and evaluation length which results in lower computational requirements.

Therefore, with the exponential growth of the use of mobile devices in all social levels and the potential ubiquitous access to educational resources and tools open up new possibilities for educational innovation to democratize access to learning intelligently and independently of time and space. So in the following section it is presented an application developed on a mobile platform (Android) that allows deploying the architecture of an ITS's-C and implementing the diagnosis by Computerized Adaptive Tests of modular and distributed way using tablets and smartphones.

2. A Mobile Adaptive Test for ITS-C

In this section are presented the features of the Mobile Computerized Adaptive Test (M-CAT) application: firstly it is showed its architecture, technologies and profiling of the users used for its implementation. Eventually, it is described the functionality and performance of the M-CAT.

2.1 M-CAT application characteristics

First we will briefly refer *mobile learning* and *ubiquitous learning*, supported on these concepts; we will discuss the idea of generic architecture to adopt in the development and implementation of M-CAT.

Mobile Learning happens when the student is away from his usual place of learning. One consequence of the use of mobile devices is that learning can take place in places of interest [14], [15], but also that it is possible to redefine and provide experience in formal environments. In this way, mobile learning is linked to the paradigms “anytime” and “anywhere”.

Ubiquitous Learning facilitates that every place can result in a learning space for the user that intelligently connects both objects, people, devices and even other learning spaces, and which may appear learning opportunities tailored to the context and personalized to user. One way to think about the difference between mobile learning and ubiquitous learning is that while mobile learning takes computers out of the classroom to the world, in the ubiquitous learning the world becomes the classroom and on the computer [16].

Ubiquitous Learning Environment based on ITS-C is understood as a virtual space-oriented and aimed at the acquisition of knowledge (independent of time and space) through the deployment of an ITS-C and the implementation of some components. Both students and teachers have access to the services offered by various mobile devices.

Defined the underlying concepts, then we describe briefly the generic architecture which supports our proposal.

2.1.1 M-CAT. Generic architecture

The generic architecture is organized in three layers or levels that operate on a technological infrastructure (Figure 4). The components and levels are: a) Technology infrastructure. b) Deployment level. c) Implementation and distribution level. d) Interaction level.

Each level offers a number of benefits and services according to the user's profile.

The *Technology infrastructure* of M-CAT was developed to run on mobile devices (smartphones and tablets) on the Android platform, the main features of the architecture are:

- The structure of the Android operating system consists of applications running on a Java framework for object-oriented applications on the core Java libraries on a Dalvik virtual machine with runtime compilation. Libraries written in C include a GUI manager (surface manager), an OpenCore framework, a relational database SQLite, a programming interface API OpenGL ES 2.0 3D graphics, a WebKit rendering engine, SGL graphics engine, SSL and Bionic C standard library.
- Most applications are written in Java, there is not a Java virtual machine on the platform. The Java bytecode is executed, but is first compiled into a Dalvik executable and run on Dalvik Virtual Machine Dalvik. Dalvik is a specialized virtual machine designed specifically for Android.

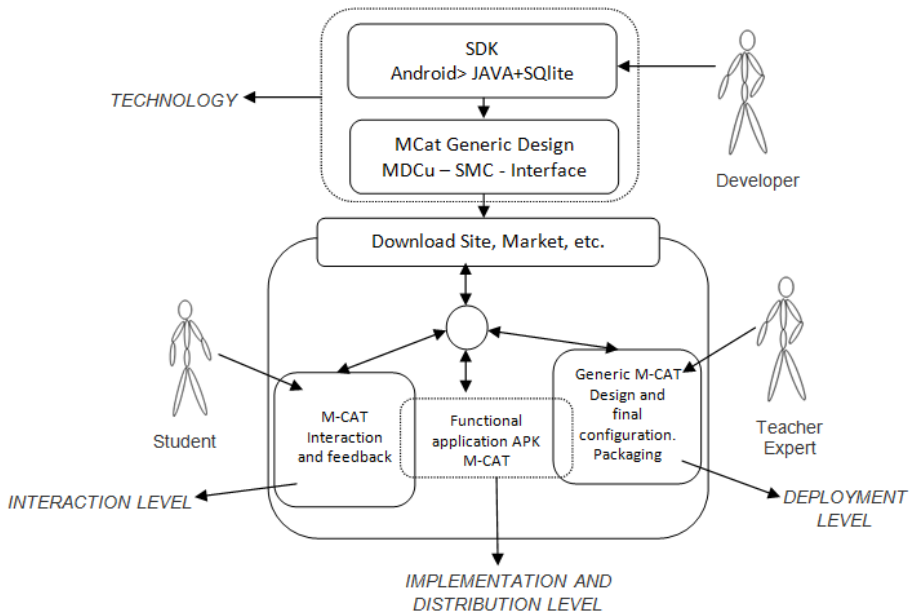

Figure 4. Architecture and technology used in M-CAT.

- We have used the Java language and for persistent storage of data we have implemented a SQLite database.
- The development of generic design of M-CAT was made on Android using the SDK. The result is an APK that can be downloaded by the expert teacher for parameterization and distribution (Fig. 4). Or a project package that can be worked through by Android Development Tools (ADT) plugin for the Eclipse integrated development environment (IDE).
- The Android application development does not require complex programming languages to learn. All that is needed is an acceptable knowledge of Java and access the software development kit (SDK) provided by Google which can be downloaded free. All applications are compressed into File Application Package (APK package is a variant of the JAR format Java and is used for distributing and installing bundled components for the Android platform), which can be easily installed from anywhere in the file browser most devices.

Deployment level: it facilitates to the expert teacher designing M-CAT on some domain of knowledge, including the construction of the item bank and operating parameters. On this level, the expert teacher is responsible for designing parameterize M-CAT, provides all the information necessary for implementation:

- Parameters of the M-CAT, after downloading the M-CAT the teacher has two alternatives of parameterization:
 - From a mobile device: using the functionality of the interfaces provided by the application (Figure 5), which have to enter data for the modules (quantity, description), evaluation criteria and ending, etc. Finally, should configure the item bank, item quantity,

description, answer choices, etc. As well as to assess the usefulness of each items in accordance the criteria established in the model.

- The other possibility is to work directly on the project package (through integrated development environment that includes ADT, such as Eclipse) and incorporate directly the SQLite database respecting the prescribed format for M-CAT.

The next step consists in the generation of the FM-CAT (APK application) for distribution.

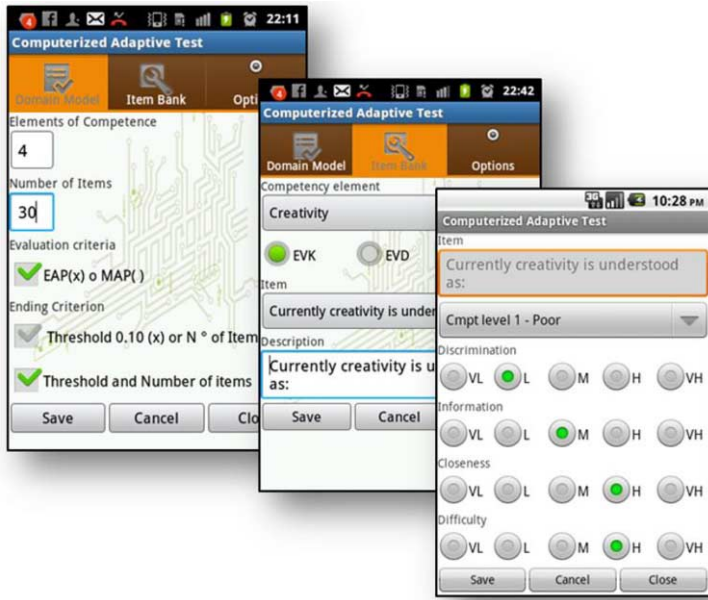

Figure 5. M-CAT -Teacher interface features.

Implementation and distribution level: After defining the specifications for the deployment of ITS-C, the expert teacher generated mobile client application for the students.

- Packaging and distribution: then distribute it for students use.
 - According the specifications set by the teacher, the packaging can build the application ready to be installed on a device, this application will consist of a client application and the deploy data in the ITS-C.
 - The layout provides the application. It can be done via Android Market, download site or any means of distribution.

Interaction level: This level chases two main aims, first to allow students access on their mobile devices to M-CAT able to assess competencies modularly with feedback to fingertips, second to facilitate teacher to receive feedback from students and analyze information of the interactions:

- Student. It is the ultimate receiver of the M-CAT, download and install the application, perform the proposed test and interaction (Figure 6). He is admitted to:
 - Check status of student model.
 - Select competency element to assess.
 - Set up system options.
 - Perform the M-CAT.
- Teacher. Receives feedback information and has the possibility to analyze the process and outcomes of the experience.
 - Receives and processes information feedback.
 - Check status of student model of each student.
 - Generate statistics and reports.
 - Executes processes adjustment for future versions.

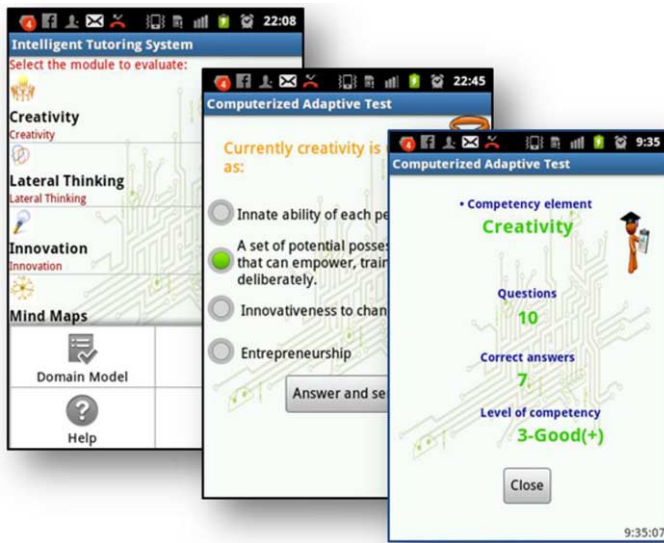

Figure 6. M-CAT –Student interface features.

2.2 Performance

Here an illustrative example that deploys the modular architecture of an ITS-C and implements the diagnostic by a Mobile Computerized Adaptive Test (M-CAT) developed by using an Android platform.

Let us suppose that is being evaluating a student by an M-CAT in evidence node ev_k , whether the probability distribution of competence levels and the correspondent characteristic curves are defined. Therefore, the process is carried out as follows:

It is selected item with $\max(X_i^k)$ and the item is showed to the student (Figure 7).

According to the answer provided by the student the updating process is carried out (See section 1.3). And again the ITS-C provides a new item to the CAT that the student receives in her/his M-CAT app.

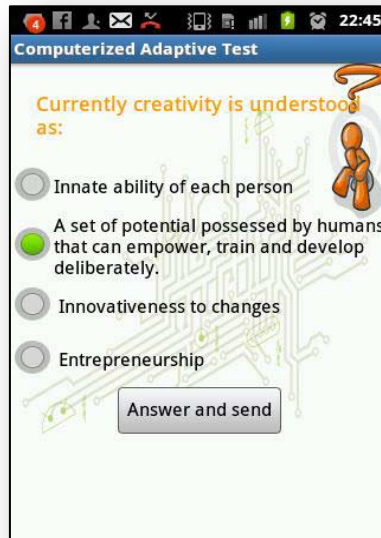

Figure 7. Question within a CAT implemented in an Android application for mobile devices.

3. Conclusions

We have presented an application developed on a mobile platform (Android) that allows deploying the architecture of an ITS's-C and implementing the diagnosis by Computerized Adaptive Tests of modular and distributed way using tablets and smartphones. The modular architecture of the domain model on an ITS-C and the diagnosis based on M-CAT has proven efficiency and lower computational requirements. Although the application does not cover all modules of the ITS-C, its current version can be a useful tool to assist with a potential ubiquitous access to educational resources and open up new possibilities for educational innovation to democratize access to learning intelligently and independently of time and space.

References

- [1] E. Wenger, "Artificial intelligence and tutoring systems," ed: Morgan Kaufmann Publishers, Inc., 1987.
- [2] J. Bourdeau and M. Grandbastien, "Modeling Tutoring Knowledge," in *Advances in Intelligent Tutoring Systems*. vol. 308, R. Nkambou, et al., Eds., ed: Springer Berlin / Heidelberg, 2010, pp. 123-143.
- [3] R. Nkambou, "Modeling the Domain: An Introduction to the Expert Module," in *Advances in Intelligent Tutoring Systems*. vol. 308, R. Nkambou, et al., Eds., ed: Springer Berlin / Heidelberg, 2010, pp. 15-32.
- [4] M. Badaracco and L. Martínez, "An Intelligent Tutoring System Architecture for Competency-Based Learning," in *Knowledge-Based and Intelligent Information and Engineering Systems*. vol. 6882, A. König, et al., Eds., ed: Springer Berlin / Heidelberg, 2011, pp. 124-133.
- [5] M. Badaracco and L. Martínez, "A fuzzy linguistic algorithm for adaptive test in Intelligent Tutoring System based on competences," *Expert Systems with Applications*, vol. 40, pp. 3073-3086, 2012.
- [6] A. Catalano, et al., Eds., *Curriculum design based on standards of occupational competence* (Concepts and methodological guidelines. Buenos Aires: CINTERFOR OIT, 2004, p.^pp. Pages.

- [7] E. a. G. Zalba, N (2006, 20/02/2008). *An approach to education based on competencies*. Available: http://www.me.gov.ar/spu/guia_tematica/CPRES/cpres-comision.html
- [8] E. S. Europe TUNING. (2000, 20/09/2009). *Una introducción a la contribución de las universidades al proceso de Bolonia*. Available: http://tuning.unideusto.org/tuningeu/images/stories/Template/General_Brochure_Spanish_version.pdf
- [9] M. Badaracco and L. Martínez, "Architecture and Diagnosis for Intelligent Tutoring System based on Competency-based Education," in *Technical Report: CIATIC-Centro de Estudios Avanzados en TIC, UJA.*, ed. Jaén, España., 2012.
- [10] E. Guzmán, et al., "Adaptive testing for hierarchical student models," *User Modeling and User-Adapted Interaction*, vol. 17, pp. 119-157, 2007.
- [11] W. J. van der Linden and R. K. Hambleton, Eds., *Handbook of modern item response theory*. New York: Springer Verlag., 1997, p.^pp. Pages.
- [12] J. O. Ramsay, "Kernel smoothing approaches to nonparametric item characteristic curve estimation," *Psychometrika*, vol. 56, pp. 611-630, 1991.
- [13] R. J. Owen, "A bayesian approach to tailored testing (Research Report No. 69)," in *Educational Testing Service*, W. J. v. d. Linden, Ed., ed. Princeton, 1969, pp. 69-92.
- [14] E. Soloway, et al., "Science in the Palms of Their Hands," *Communications of the ACM*, vol. 42, p. 21, 1999.
- [15] Y. Rogers, et al., "Ambient wood: designing new forms of digital augmentation for learning outdoors," in *Proceedings of the 2004 conference on Interaction design and children: building a community 2004*, pp. 3-10.
- [16] D. Ley, "Ubiquitous Computing," *Emerging Technologies for Learning*, vol. 2, pp. 64-79, 2007.

An Empirical Study on the Effects of Embodied Conversational Agents on User Retention Performance and Perception in a Simulated Mobile Environment

Ioannis Doumanis¹ and Serengul Smith

Middlesex University, The Burroughs Hendon, London NW4 4BT

Abstract. The paper presents a user study designed to examine the impact of the presence of a multimodal ECA on the user's ability to retain content of cultural value with variable degree of difficulty (i.e., technical and simple content). The study was conducted in the lab, using a high resolution panorama representing four locations in an archaeological attraction. The content participants perceived differed both in terms of complexity and length. Participants interacted with an ECA-based system and then with a non-ECA system that provided content about popular locations in the attraction. Results indicate that participants who used the system with the ECA retained content of variable difficulty more consistently, than those who used the system without the ECA. However, we also found that if text is added as an additional output modality to an ECA-based information system it can positively impact the perception of the technical content, which can potentially lead to enhanced retention of technical content.

Keywords: Embodied conversational agents, human-centered computing, mobile tour guides, information systems

Introduction

Evolution in the area of mobile computing has been phenomenal in the last few years. The exploding increase in hardware power has enabled multimodal mobile interfaces to be developed. These interfaces differ from the traditional graphical user interface (GUI), in that they enable a more “natural” communication with mobile devices, through the use of multiple communication channels (e.g., multi-touch, speech recognition, etc.). As a result, a new generation of applications has emerged that provide human-like assistance in the user interface (e.g., the Siri conversational assistant) [1]. These conversational agents are currently designed to automate a number of tedious mobile tasks (e.g., to call a taxi), but the possible applications are endless. A domain of particular interest is that of Cultural Heritage, where conversational agents can act as personalized tour guides in, for example, archaeological attractions. The visitors to historical places have a diverse range of information needs. For example, casual visitors have different information needs from those with a deeper interest in an

¹ Corresponding Author: Middlesex University, The Burroughs Hendon, London NW4 4BT; Email: ioannis.doumanis@lsst.ac

attraction (e.g., - holiday learners versus students). A personalized conversational agent can access a cultural heritage database, and effectively translate data into a natural language form that is adapted to the visitor's personal needs and interests. The study presented in this paper focuses on the information needs of a specific type of visitors, those for whom retention of cultural content is important (e.g., students of history, cultural experts, history hobbyists, educators, etc.). Embodying a conversational agent enables the agent to use additional modalities to communicate this content (e.g., through facial expressions, deictic gestures, etc.) to the user. Simulating the social norms that guide the real-world human-to-human interaction (e.g., adapting the story based on the reactions of the users), should at least theoretically optimize the cognitive accessibility of the content. Although a number of projects have attempted to build embodied conversational agents (ECAs) for cultural heritage [2, 3], little is known about their impact on the users' perceived cognitive accessibility of the cultural heritage content, and the usability of the interfaces they support. In particular, there is a general disagreement on the advantages of multimodal ECAs in terms of users' task performance and satisfaction over non-anthropomorphised interfaces.

We present a user study designed to evaluate the impact of the presence of a multimodal ECA on the cognitive accessibility of a mobile tour guide system, providing cultural content of variable difficulty. The system consists of a no-ECA version (control condition) and a version with an ECA capable of augmenting the acoustic information with relevant non-verbal behaviours (e.g., pointing gestures to direct user's attention focus to aspects of interest of a particular location). In a within-subjects design 14 participants interacted with both systems each with cultural content of variable complexity (i.e., simple and technical content). We evaluated the question of the impact of the presence of the ECA on the retention performance and perceived cognitive workload, as an indication of how participants felt about using the systems to uncover information about the specified locations. The study was conducted in the lab using a high-resolution panoramic application (see Figure 1).

The panoramic application included the photographic representation of four locations of the archaeological attraction and there were no on-screen buttons for users to interact with. An on-screen menu (see Figure 1), allowed users to visit the locations in any order they liked. To start the information presentation the system had to decode the name of the location from a QR-Code (shown as a camera icon in Figure 1) embedded in each location the user visited. A QR-Code is a simple two-dimensional bar-code that can be used as a cheap solution for physical location/object identification. In the current implementation the user has to photograph a QR-Code using the integrated camera of the tablet device. We had the following hypotheses:

- *"The degraded retention of complex information"*- The presence of a multimodal ECA has a negative impact on the retention of the technical information, for example, because it adds an extra burden to the already overloaded cognitive resources of the user (because of the complex nature of the technical information), but neither a positive nor a negative effective for the simple information.
- *"The enhanced retention of complex information"*- The presence of a multimodal ECA increases the participant's retention performance with the technical information, for instance because it reduces the cognitive loads (e.g., by rendering the interaction smoother) needed for retaining such information, but has no effect (neither positive nor negative) on the simple information.



Figure 1. A screenshot of interactive panoramic applications

1. Related and Previous Work

The impact of Embodied Conversational Agents (ECAs) on the user's ability to retain information has been analysed in a number of prior studies [2, 3]. In one study [2], the impact of a mobile effective tour guide was evaluated on the users' recall performance under realistic mobile conditions. Three different types of mobile guide were evaluated in an interactive tour of the "Los Alamos" site of the Manhattan project. All stories generated by the system, related to the "Making of the atomic bomb". The physical tour, however, took place at the Heriot-Watt Edinburgh campus buildings, where buildings from the "Los Alamos" site were mapped onto University buildings. The agents differed in terms of emotions and attitude, portrayed by a simplistic 2D cartoon-like head, and by the inclusion of the agent's perspective and experiences in the narration. The fully affective guide could exhibit both emotions and attitude while the other two displayed no emotions nor attitude, or emotions but no attitude respectively. For example, the emotional guides could dynamically update the story to include their own feelings and perspective about historical facts (e.g., "*it seemed brutal to be talking about burning homes*"). The participants were requested to listen to at least three stories at each location, under a thematic area of their choice (e.g., Science or Military). After the completion of each story, participants had to rate the degree of interest of the stories, as well as how much they agreed with the guide's argument. In the first group (i.e., the fully affective guide), the input given influenced the processing conducted by the guide, while in the other two it merely gave the impression that it did. Upon completion of the tour, participants had to answer two sets of questionnaires, one to indicate their subjective experience of the system, and another to test their recall levels of the information they listened during the tour. In terms of recall performance, the researchers found no significant differences in the users' recall levels of the presented information between the three guides. They attributed this to various confounding variables, such as the speed of the guide's voice, non-native English speaking users, etc.

We find this non-effect result to be rather expected. Although the conclusion that a guide with attitude and intelligence makes the interaction more interesting may be a valid conclusion, it is how these behavioural attributes are portrayed through non-verbal means that can translate subjective views into enhanced retention performance. For example, studies have shown that a more realistic depiction of a virtual human [4] can create greater participant involvement in a virtual experience. In addition, the absence of body language (e.g., beat gestures) deprived the guide of a valuable communication channel that would augment the presented information and, in turn, lead to greater user retention performance. Last and perhaps most importantly, the pretended Los Alamos site at the University campus made it impossible for the users to connect the content of the stories with their surrounding environment, thus causing unnecessary cognitive overload [5]. If the user's cognitive resources were devoted into blocking the external stimuli in order to focus his/her attention to the stories, it is not surprising that the attitude and emotions of the agent had no impact on his/her overall retention performance. If the study had been conducted on the actual site, where users would have the ability to physically visit the various sites, the results may have been different.

In another study [3], the impact of an ECA on motivation and learning performance in a repeated task over a period of time was evaluated in a laboratory setting. In the study, each group of participants experienced a vocabulary trainer application, either with an ECA (*with-agent* version) or without an ECA (*no-agent* version). In the no-agent version, the user interface consists of two windows displaying the English and German expressions and a row of buttons for showing and rating the answer. In the with-agent version, a female ECA was added in the middle of the screen featuring some idle movements to make her look alive and with a minimum amount of gestures. The researchers found a "Persona Zero-effect", i.e., that they found neither positive nor negative effects on motivation and learning performance. Therefore, it was concluded that adding an ECA on an interface does not benefit performance but also does not distract. The no-effect results produced by this study, is in fact, encouraging. If the mere presence of an ECA (with minimal or without nonverbal communicative behaviours) in a learning environment has no detrimental effects on performance, then it could be assumed that endowing ECAs with a full repertoire of proper nonverbal behaviours might, in fact, improve performance. Comprehension can be directly affected by redundancy [6] and, hence, the use of an additional, redundant channel of communication, such as gestures or facial expressions, could result in more learning. In particular, the use of gestures could reduce message ambiguity by focusing learner attention, and facial expression can reflect and emphasize the agent message, emotions, personality and other behaviour variables [7]. Our study attempts to examine the validity of this hypothesis.

2. Prototype systems

For the current study, we developed two tour guide applications one featuring a multimodal ECA and another without an ECA on the interface. Each system, used photographs of each of the locations the user would encounter as a background. The ECA could refer to objects in its background and to additional information that appeared in a floating 3D window. A dialogue window provided users with the ability to have a short "get-to-know-each-other" dialogue with the system (e.g., about how to

use the system). A control window provided access to the device's on-board camera and to an interactive map of the castle that showed the locations users had to visit. The non-ECA system (see right side of Figure 2) features the same interface elements, but instead of an ECA a subtitle window "reads" the system contents while highlighting each word of the text.

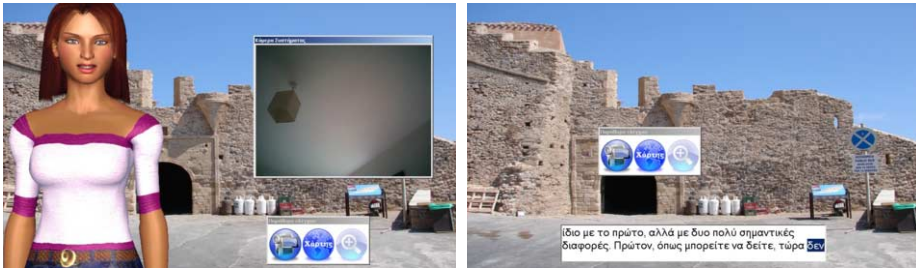

Figure 2. The system with the ECA (left side) and the system without the ECA (right side)

3. User Study

Population: In total, fourteen users (both males and females) from a variety of age groups took part in this study. The participants were randomly assigned to two groups of seven. None of the participants was either a local-resident or had visited the area before. This was done to avoid over-familiarity with the area. All participants were native Greek speakers and had a variety of academic and mobile-computer backgrounds.

Task: The goal of this experiment was to investigate different information presentation systems capable of providing content of variable difficulty about attractions in the castle, with respect to their effects on their ability to effectively retain information. Participants were asked to use an interactive panoramic application to visit four locations in the castle (in any order they like) and retrieve information with varying degree of difficulty (simple then technical or vice versa), once using system A (i.e., with the ECA) and once using the system B (i.e., without the ECA). The technical content was a technical description of the locations, while the simple content was taken from the information leaflet the castle provides for free to all visitors. The total duration of each tour was not more than 20 minutes. Furthermore, participants were informed that an experimenter would be present in the lab to observe their behaviour while using the system and to provide help if necessary (e.g., if they could not use the camera to photograph a QR-Code). In addition, they were told that after visiting all locations, they would be asked to indicate in a test what they retained from the presentations. At the beginning of each task, the system asked participants to provide their personal details (i.e., name, gender and age) and to parameterise various features of the agent and the system (e.g., the ECA's appearance, volume, etc.). After that, a computer agent appeared either in the form of an ECA or a disembodied voice with a subtitle window. In order to start a presentation, participants had to click on a button embedded in each of the locations they visited using the panoramic applications. The button activated a QR-Code that users had to photograph using the device's camera. Once the QR-Code was decoded, the system would present the relevant information

about the particular location (simple or technical). After completely uncovering information for all four locations, participants were asked to indicate, on a five-point scale, whether they found the presentations difficult. Next, a retention test was administered which asked questions about the information they heard in each of the locations. Finally, participants were asked to indicate, their perceived cognitive workloads associated with the presentations they experienced with each of the systems, on a seven-point scale questionnaire.

Measures and Methods: The only objective variable in the experiment was the answers to the retention test. The subjective measures were the responses to the items of the questionnaire, and the ratings of the difficulty of the presentations. The retention test used the same fill-in-the-blanks approach. The questionnaire items used the same seven-point agree-disagree Likert [8] format (1=strongly disagree, 7=strongly agree), and measured the perceived cognitive workload, as an indication of how the participants felt about using the systems to uncover information about the specified locations.

4. Results and Discussion

Performance Measures: We measured the amount information participants recalled from each type of content as an indicator of the effectiveness of each system (ECA present or ECA absent) in eliciting recall performance. A series of 2 x 2 ANOVAs, taking the score and confidence as dependent variables, and type of ECA (ECA-present vs. ECA-absent), order of presentation (simple then technical vs. vice versa) and type of content (simple vs. technical) as independent variables did not show any significant effects of any of the independent variables. There were no significant interactions either.

Table 1. Mean retention performances.

Order of presentation	ECA (Content) (n = 14)	Mean	Std. Deviation
Simple / Technical	Present (Simple)	25.1	13.4
	Absent (Technical)	21.8	10.99
Technical / Simple	Present (Technical)	21.1	11.9
	Absent (Simple)	36.8	22.4

However, (see Table 1) the participants' performances were more consistent with content of varying difficulty with the system with the ECA, than with the system without the ECA. Participants using the system with the ECA performed almost the same between the two content conditions (mean S/T = 25.1 vs. mean T/S = 21.1). Those participants that used the system without the ECA performed better with the simple content (mean Simple = 36.8) than with the technical content (mean Technical = 21.8). This is a strong indication that the modalities used by the ECA (voice, gestures, etc.) were more effective in enhancing the participants' ability to retain information of variable difficulty about the locations of the castle than the modalities used in the system without the ECA. This finding invalidates the hypotheses examined ("*The degraded retention of complex information*" and "*The enhanced retention of complex information*") as the ECA does not result in enhanced or degraded retention

performances. In fact, it has no measurable impact on either the simple or the technical information content. Conversely, the variation of the content affected the participants using the system without the ECA. Their performance was better with the simple content than with the technical content. Hence, we can safely say that the presence of an ECA does not enhance information retention, but it can provide a more consistent method of presentation for cultural content of variable difficulty, than a system without such an artefact on the interface.

Subjective Assessment - Workload Questionnaire: Participant subjective impression of the cognitive workload required to navigate the routes was measured by nine-sets of questionnaire items rated on 7-point Likert scales. The first set of items assessed the complexity, learnability, consistency and self-organization requirements of the information task, and it includes six questions (Cronbach's $\alpha = 0.850$). The second set includes four items, and it was designed to assess how participants perceived the output modalities (visual, auditory and textual) of the prototypes in terms of sensory, satisfaction, and understanding (e.g. visibility of the screen, confusion caused by the multiple modalities, etc.) (Cronbach's $\alpha = 0.646$). The third set evaluated how the participants perceived the feedback they received from the prototypes in terms of sensory, timing, relevance and memory requirements (e.g., relevance of the output to the environment of the castle, support to photograph correctly the QR-Codes, etc.). This question set includes six items (Cronbach's $\alpha = 0.653$). The fourth question set evaluated the working memory requirements of the prototypes. It includes four items (e.g., amount of information to hold in mind when using the prototypes, how the system should respond when a participant is confused\overloaded with information, etc.) (Cronbach's $\alpha = -0.029$). The fifth set assessed the emotional impact of the prototypes (e.g., frustrating, annoying, etc.), and it includes four items (Cronbach's $\alpha = -4.410$). The sixth set assessed how the prototypes impact the participants' long-term memory in terms of the task learnability and in relation to their existing knowledge (e.g., ease of learning of the information, relation of information to the participant's interests, etc.) (Cronbach's $\alpha = 0.503$). This question set consists of four items. The seventh set evaluated how effectively participants could access the underlying structure of the information task, and it consists of four items (e.g., simplicity of the presented information, how the structure of the information is presented, etc.) (Cronbach's $\alpha = 0.700$). The eighth set assessed how the participants perceived the rationality of their responses, and how supported they felt during their responses. This question set consists of four items (e.g., allowances for response errors, frequency of response errors i.e., wrongly retained information, etc.) (Cronbach's $\alpha = 0.446$). The final set evaluated how the participants perceived their output responses and how supported they felt in order to respond appropriately. It includes four items (e.g., ease of finding the selected locations, support to learn the information provided, etc.) (Cronbach's $\alpha = 0.536$).

For all analyses, we performed a series of 2 x 2 ANOVAs, taking each questionnaire item as a dependent variable, the type of ECA, the type of content, and order of presentation as independent variables. We found significant effects and interactions on the following items:

- “The information task is too complex”
- “The process of extracting information from the system is difficult to learn”

- “It’s hard to learn any of the information presented by the system”
- “The completion of the information task requires too much self-organization”

On the difficulty of the information task there was an effect of the order of presentation ($F(1, 24) = 9.422$; $p < .01$) and an interaction between the type of content and the type of ECA ($F(1, 24) = 9.422$; $p < .01$). The significant interaction between the type of ECA and the content was further analysed using simple main effect analysis. It revealed that the variation of content across the order conditions significantly influenced how the participants perceived the complexity of the information task with both the system with the ECA ($F(1, 24) = 4.342$; $p < .05$) and the system without the ECA ($F(1, 24) = 5.095$; $p < .05$). Participants perceived the technical content as less complex than the simple content, when each type of content was presented by the system without the ECA. Then, they perceived the simple content as less complex than the technical content when each type of content was presented by the system with the ECA. The technical content may have seemed easier with the system without the ECA because of the text and voice used as output modalities. Then, because the presence of an ECA makes an interface more user friendly and the simple content was simple enough to understand with or without the ECA, it may have seemed to participants that the complexity of the task is lower with the system with the ECA than with the system without the ECA.

On the learnability of the process of extracting information there was an effect of the order of presentation ($F(1, 24) = 8.075$; $p < .01$) and an interaction between the type of ECA and type of content ($F(1, 24) = 8.075$; $p < .01$). The significant interaction between type of content and type of ECA was further analysed using simple main effect analysis. It showed that the variation of content across the order conditions significantly influenced how the participants perceived the difficulty of learning how to extract information from the system without the ECA ($F(1, 24) = 9.084$; $p < .05$) but not from the system with the ECA. Participants perceived the process of extracting information from the system without the ECA as more difficult to learn with the simple content than the technical content. The variation of content did not impact on how the participants perceived the learnability of the process when using the system with the ECA. Most likely, the modalities used by the system with the ECA made it easier for participants to learn how to extract information from the system.

On the learning of the information presented by the systems there was an effect of the order of presentation ($F(1, 24) = 7.032$; $p < .05$) and an interaction between the type of ECA and type of content ($F(1, 24) = 7.032$; $p < .05$). A simple main effect analysis on the interaction between the type of ECA and the type of content, showed that the variation of the content across the order conditions significantly affected the participants using the system with the ECA ($F(1, 24) = 6.251$; $p < .05$) but not the participants using the system without the ECA. Participants perceived the technical content as easier to learn than the simple content when it was presented by the system with the ECA. Therefore, we argue that the system with the ECA not only provides a more consistent method of presentation (see “Performance Measures”), but it also has the potential to enhance information retention of technical cultural content. As discussed later in the comments, participants felt that both contents were difficult to memorize, which explains the overall high ratings for this item with both systems. However, it seems that participants may have felt that the system with the ECA renders the interaction smoother thus making it easier for them to retain such information. This provides some evidence that supports my enhanced retention of complex information

hypothesis (“*The enhanced retention of complex information*”). However as the objective measures failed to produce any significant results, it is hardly possible to draw any conclusions solely based on subjective evidence.

Finally, on the self-organization of the information task there was an effect of the order of presentation ($F(1, 24) = 5.481$; $p < .05$) and an interaction between the type of ECA and type of content ($F(1, 24) = 7.032$; $p < .05$). Participants perceived the self-organization requirements of the technical content as higher than the simple content, when each type of content was presented by the system with the ECA. On a contrary, they perceived the self-organization requirements of the technical content as lower than the simple content, when each type of content was presented by the system without the ECA. However, the simple main effects analysis failed to reach conventional significance levels for either the system with the ECA or the system without the ECA. A possible explanation is that the text used by the system without the ECA in the technical presentations was more natural for participants to read than watching an ECA on the screen giving information acting almost, but not perfectly, like an actual human being.

Curiously, the participants’ retention performances do not follow the findings reported above. One would expect that since the system without the ECA renders the technical task less difficult and with less self-organization requirements, it would translate to enhanced retention performances with the system without the ECA. Then, if participants thought that it is easier to learn the technical information with the system with the ECA than with the system without the ECA their motivation should have resulted to enhanced retention performances. However, as it can be seen from Table 1, participants’ retention performances when experiencing the technical content were similar with both systems (mean ECA absent = 21.8 vs. mean ECA present = 21.1) and improved when experiencing the simple content (mean ECA present = 25.1 vs. mean ECA absent = 36.8) with the system without the ECA. A possible explanation is that regardless of how the participants perceived the technical task with the system with the ECA, the modalities it used impacted their ability to memorise the content equally, as the modalities used by the system without the ECA.

Participant Comments: Participants were asked to comment freely on each of the systems. To analyse the gathered data a custom-made approach was used. In particular, the group of participants was divided into a “Feedback” and a “Confirmation” group. Each group consisted of an equal number of participants randomly chosen from the experimental conditions. If a participant had not provided feedback, s/he was excluded from the groups. We looked in the feedback group for comments based on:

- Frequency: These were groups of comments that frequently arose around a specific event encountered or feature of the systems (e.g. ECA design, experiences with the multimodal content, etc.). As a frequency threshold for these patterns, we defined 40% of the total number of participants in the feedback group.
- Fundamentality: These were comments that although did not frequently arise were deemed be fundamentally important in terms of the possible effects of ECA on the user’s experience of the prototypes.

Then, we looked in the confirmation group for comments that corroborated the patterns and/or comments of the feedback group. If a match was found in the confirmation group then, the pattern/comment of the feedback group was considered as corroborated.

If a match was not found the pattern/comment of the feedback group was considered as uncorroborated. As participants in both groups were taken at random from the experimental conditions, views were mixed and therefore uncorroborated patterns/comments could arise in the analysis. Below, we report only the corroborated patterns and comments grouped into relevant topics for simplicity.

ECA Design:

- 1) Certain features of the avatar can be improved. These include:
 - Decrease the rate of the ECA's speech to make memorization easier
 - Better body gestures
 - More natural voice to avoid the speech discrepancies.

This corroborated pattern, suggests a number of improvements to the design of the ECA that, if implemented correctly, they could make memorization of the content easier. Participants did not have any comments about the photorealism of the ECA, which leads me to assume that it was acceptable, and focused only on the improvement of the ECA's behaviours and voice.

Multimodal Content Design:

- 1) The content is difficult to comprehend and memorize for most users. This could be because of the nature of the content, as it was suggested by a participant. A content of more historical value and without so many dates (as opposed to information about the construction of the churches), could be of more interest to the users.

This pattern was corroborated by a number of participants. It shows that a different type of content (i.e., of a more historical value without so many dates) would be of more interest to the users. It also provides a possible explanation why participants scored overall low in the retention tests using both systems. A more personalised content to the preferences of participants may reveal stronger differences between the two systems (ECA-present and ECA-absent).

Application Design;

1) New Features

- Zoom-in options to better see the artefacts for which the system is providing information.
- A pause button to pause the presentation on demand.

The above corroborated pattern and comment reveal features that should be added to the systems. Participants requested a pause button and a zoom option for the artefacts the system is providing information about. Although the ECA pointed to the artefacts, the resolution of the background images was low. The zoom feature will most likely make comprehension of the narrated content easier.

2) Improvements in the existing design

- A number of participants had problems photographing the QR-Code

The comment above require improvements in the process of photographing the QR-Codes in the locations. According to the observations made by the experimenter, participants experienced two types of problems with the QR-Codes: a) some of the participants had problems photographing a QR-Code, as the lab was too bright. This can be solved by adding a higher resolution camera to the device. b) When the ECA was present, the experimenter noticed that the “click” sound of the system’s camera did not work consistently. This was to be expected, as the UMPC device had to process the graphics of the avatar, in addition to the video stream needed to photograph the QR-Codes. The latest generation of UMPC devices offers significantly more processing and graphics power, than the device used in this experiments.

5. Conclusion and Future Work

This study examined the effect of an ECA compared with a text/voice system in helping users extracting content with varying degree of difficulty in a simulated outdoor environment. In this study, participants using a multimodal ECA performed more consistently with the content, that those who used the system with text and voice output. However, qualitative evidence indicates that an ECA with text as an additional output modality can positively impact the perception of the technical content. This can potentially lead to enhanced retention of technical information.

Qualitative results revealed that the cognitive load of participants, with regards to the organization and implementation requirements of the information task, was affected by the complexity of the content, and the type of system that presented it. The system without the ECA lowered the difficulty and self-organizational requirements of the technical task, but placed more demands to the participants in terms of its learnability. The system with the ECA, on the other hand, lowered the learnability of the technical task, but had a detrimental effect on the perception of its difficulty and self-organization. Although this finding can be generalised only with caution, the careful use of text as an additional output modality when presenting technical content in an ECA-based mobile guide system can be beneficial for users rather than degrading. Then, the use of QR-Codes as a technique of content-tagging random locations in an outdoor attraction was received positively by the participants even under simulated conditions. Although some participants experienced issues with photographing accurately a QR-Code the first time, they all managed to complete a full tour with both systems with no prior training.

Overall, this study provided quantitative and qualitative evidence to support the “Persona Zero-Effect” [3] that an ECA has no negative or positive impact on the users experiencing cultural content in simulated mobile conditions. However, my results also suggest that by augmenting the output modalities of an ECA with text when presenting technical content can be beneficial for users rather than degrading.

6. References

- [1] Apple Inc., (2013). "Siri Personal Assistant". (Available from: <http://www.apple.com/ios/siri/>) [Accessed February 19 2013].
- [2] Lim, Y., Aylett, R. (2007): "Feel the difference: a guide with attitude!" In Pelachaud, C., Martin, J.C., Andre, E., Chollet, G., Karpouzis, K., Pele, D., eds.: *Proceedings of the 7th International Conference on Intelligent Virtual Agents (IVA)*, Springer (2007) pp. 317 – 330.
- [3] Miksatko, J., Kipp, K.H., Kipp, M. (2010): "The Persona Zero-Effect: Evaluating virtual character benefits on a learning task." In: *Proceedings of the 10th International Conference on Intelligent Virtual Agents (IVA-2010)*, September 20-22, 2010, Philadelphia, PA, USA, pp. 475-482.
- [4] MacDorman, K. F., Gadge, P., Ho, C.-C., Mitchell, W. J., Patel, H., Schermerhorn, P. W., & Scheutz, M. (2010): "Probing people's attitudes and behaviours using humanlike agents." *Research Poster IUPUI Research Day*. April 9, 2010. Indianapolis, Indiana.
- [5] Hollan, J., Hutchins, E., & Kirsh, D. (2000): "*Distributed Cognition: Toward a New Foundation for Human Computer Interaction Research*". *ACM Trans. on Computer-Human Interaction*. **7 (2)**, pp. 174-196.
- [6] Nemetz, F., & Johnson, P. (1998): "Towards Principled Multimedia" [online]. University of London. Available from: <http://www.bath.ac.uk/~mapfn/chi98/towards.htm> [Accessed July 15 2011].
- [7] Baylor, A. L. and S. Kim (2008): "The Effects of Agent Nonverbal Communication on Procedural and Attitudinal Learning Outcomes". *International Conference on Intelligent Virtual Agents*. Tokyo, Springer: pp. 208-214.
- [8] Likert, R. (1932): "A Technique for the Measurement of Attitudes". In: *Archives of Psychology* **140**, p.55.

Artificial Intelligence in 3D Virtual Environments as Technological Support for Pedagogy

Noha SALEEB and Georgios DAFOULAS

Middlesex University, London, UK

N.Saleeb, G.Dafoulas{@mdx.ac.uk}

Abstract. This paper researches the opportunities available to use 3D Virtual learning Environments (3D VLEs), such as Second Life, to create e-learning Project Innovation for students using 3D Virtual Design concepts and programming. This entails the use of programming and coding to create bots (artificial intelligence robotic avatars) that can be used to direct interactive teaching and learning activities inside a 3D VLE. Moreover, through the creation and coding of holographic platforms (holodecks) inside 3D VLEs, diverse classroom and environmental settings can be created to aid in the e-learning process and help the students themselves to use this technique to create immersive 3D projects e.g. 3D catalogues and exhibitions. This is in addition to the prospects of using these holodecks for educational role-play activities, modelling activities and interactive discussions and seminars.

Keywords. Artificial intelligence, E-Learning, Blended Learning, 3D Virtual Worlds, Teaching Learning Innovation, Second Life, Bots, Psychology

Introduction

3D Virtual Learning Environments (3DVLEs) have been a host for many virtual campuses of universities, e.g. Harvard and Cambridge, since their offset more than a decade ago [1]. These virtual media offer innovative opportunities for technologically supported pedagogy and e-learning for many fields of sciences and arts which has reaped noticeable participation, satisfaction and hence achievement from students [2]. Through 3D VLE online courses, online avatars allow students and their instructors to interact synchronously by audio, text chat and other media presentation techniques [3]. It thus becomes imperative to investigate the merits of migrating with delivery of e-learning to these environments.

The emergence of digitally influenced generations of students, whom Prensky [4] and Oblinger and Oblinger [5] referred to as “Digital Natives”, “Games Generation” and “Millenials”, deems it logical to anticipate why in order to enhance future learning, students are currently being encouraged to utilise game-like 3D virtual worlds, or VLEs like Second Life, Active Worlds and others to accommodate for new cognitive style changes. These play an essential role in shaping future e-learning as suggested by Wang et al. [6], specifically with the potential to bridge the gap between simple knowledge of a topic and hands-on experience with it i.e. “learning by doing” [7].

Furthermore, a paradigm shift in education also emerged called “Animated Pedagogical Agents [8]. This uses lifelike autonomous 3D characters or avatars that cohabitate the learning environment to provide a rich interactive face-to-face interface and activities with students who are also embodied in the learning environment as avatars [9]. These recently can be coded / programmed to provide an intelligent tutoring system as will be explained subsequently as part of the pedagogical practices presented in this research.

The previously described technological advances and practices support the developmental perspective of teaching and transmission of knowledge by adopting the constructivist paradigm/approach to teaching and learning. As indicated by Mikropoulos and Natsis [10] Constructivism seems to be the theoretical model the majority of the 3D VLEs are based on. This can be explained by Dalgarno’s and Lee’s [11] conception that “technologies themselves do not directly cause learning to occur but can afford certain tasks that themselves may result in learning”. Thus examples of supporting the constructivist paradigm will be seen in the following sections that fulfil the seven principles of constructivism as presented by Jonassen [12]:

1. Provide multiple depictions of reality
2. Focus on knowledge construction not reproduction
3. Produce genuine tasks
4. Provide case-based learning environments
5. Promote reflective activities
6. Enable context and content dependent knowledge construction
7. Support collaborative negotiation

The teaching/learning examples adopted and suggested for creation in this research encourage, through project work, constructing new subjective knowledge in students that is influenced by their prior experiences. Hence the constructivist approach to teaching/learning rather than objectively and passively acquiring knowledge as is the case with behaviourism [13]. Students learn as they work to understand their experiences and create meaning from it. Therefore, teachers are facilitators who create a curriculum to support a self-directed, collaborative search for meanings [14]. In this case the curriculum would encompass programming and coding bots (artificial intelligence automated avatars) inside 3D VLEs to offer interactive activities for students. As a result since students have diverse perspectives, backgrounds, learning styles and experiences, this collaborative learning environment would provide an abundance of benefits [15]. This has the possibility of increasing even more with the technological capabilities suggested above. Additionally this aligns with the developmental perspective for teaching and learning which relies on encouraging self-exploration and inquiry, by “cultivating ways of thinking” beyond the tutor’s supervision [16]. Hence, with the developmental perspective students are guided towards deriving problem solutions but not provided with them.

There is a challenge to integrate contributions from a number of different disciplines into a single learning support offering that will (i) take under consideration the pedagogic needs associated with the use of 3D VLEs, (ii) address usability and web 2.0 issues from the use of a social learning network and (iii) investigate 3D VLE interactions with the mediums used to access learning platforms. So far the creation of

intelligent 3D VLEs is primarily concerned with the design of content for virtual learning tasks.

The next section will demonstrate several educational scenarios through the creation and use of bots (artificial intelligence automated avatars) inside Second Life, an example of 3D Virtual Learning Environments, to create different interactive projects and activities to enhance students' e-learning.

1. Pedagogical Scenarios

Second Life is primarily crafted to be built and populated with content generated by its users—hence is a rich environment for content creation [17]. Along with creating solid or hollow inanimate objects, it is possible to place programmable scripts on these created objects to give them specific repetitive animations, or provide the objects with Artificial Intelligence (AI) awareness of the surrounding actions and events and hence react according to different situations and stimuli [18]. Inside Second Life these scripts are created using the Linden Scripting Language (LSL) and attached to inanimate objects or representations of avatars to animate them. These programmed avatars are called bots. This is done by placing the scripts on an object attached to the avatar, and it is this object that runs the script and controls the avatar to appear to be walking, talking etc. [18].

Bots can perform many simple interaction tasks such as to recognize approach of other avatars, ask questions, provide pre-prepared answers to questions, follow, lead or locate other avatars, turn on or off other objects, play pre-recorded animations as responses to different stimuli, collect data or information, simulate roles e.g. patient, waiter etc. The advantage of using bots is that they appear as realistic as “real” avatars, which belong to real life users, thus as indicated by Varvello and Voelker [19] can be used to conduct endless activities, social interactions and experiments at any time of day with calculated precision and efficiency. For example, Kemp and Livingstone [20] suggested setting up “tour bot” agents inside museums to greet guests and take them on a pre-determined route with descriptions of the exhibits. The stopping points and text for the descriptions sit inside the “bots” as notecards and the Logic is implemented using LSL. Bots are being increasingly used in virtual environments [21] e.g. Second Life, for their convenience as simulation platforms for testing multi-agent systems and other AI concepts that are more cost effective to use than physical ones [22].

For the purpose of this research 2 different kinds of bots were experimented with: “Pandorabots” and “Pikkubots”. These were used in association with a simulation “holodeck” as explained henceforth:

- Pandorabots are AI “minds” or “chatbots” which can be created or customised using a free open-source-based website enabling development and publishing of these chatbots anywhere on the web, including 3D VLEs like Second life. Pandorabots support the new AIML 2.0 as their knowledge content markup language. They are used due to their ease of programming and adaptability to work in any virtual reality program, for a Pandorobot mind can be easily

trained to provide certain sets of answers when asked certain combinations of questions or keywords.

- PikkuBots are bots or avatar entities created for Second Life which can be operated automatically. PikkuBot is actually a program that is usually installed on a dedicated server to automatically run inanimate avatars in "Second Life" even when the user is not at the computer. The PikkuBot can be configured to do many tasks. After installing and configuring, the bot is controlled using "commands". These are short words sent to it either using the instant messaging chat inworld (inside Second Life), typed in the command line at the bottom of the bots' GUI, or using commands sent to it directly using an inworld scripting engine placed in a concealed or visible object which triggers the command when the bot steps on it. The bots' server feeds sensory information for the characters/avatars over network connections containing the current state of the virtual world. The bots interact in the environment by sending action commands back to the server and the character moves, talks etc. [23].
- Holodecks are virtual reality platforms which can take the form of any object inside a 3D VLE but contain scripts to "rez" or materialize/create an immersive new environment around the avatar. This can be used to provide multiple alternate environments or realities, through choice from a menu, which students can engage with.

A technique to combine all 3 separate technological AI components mentioned above was used for the pedagogical scenarios presented in this research. This main merging concept for Pandorabots, Pikkubots and Holodecks was used to create multiple projects as explained henceforth. The technique used was i) Create a Pandorabot mind and train it to recognise a series of questions using combinations of keywords, then provide groups of specific answers for the bot to reply with. ii) Create/purchase an inanimate Pikkubot in Second life, customise its appearance and place the Pandorabot AI mind on it (attach it to it) to give the Pikkubot the life-like interactive conversational abilities to communicate with other real users' avatars. iii) Program a scripting engine in Second Life, a commercial example of which is "ImagiLearning Platform", which when stepped on will animate the Pikkubot's physical actions e.g. move, point etc. iv) Create/customise/script a Holodeck, build and compress all the environments/spaces/buildings which are to be rezzed from it, then place these environments inside the holodeck and script its menu to materialize them on demand. v) Adjust the scripting engine controlling the Pikkubot so that one of its commands would make the Pikkubot trigger the holodeck and rez a specific environment based on the questions and answers dialogue with the real avatar users. vi) Devise the different project scenarios to be used with the students, utilising the above created comprehensive AI system comprising of Pandorabot, Pikkubot, scripting engine, built spaces and Holodeck. Examples of this are demonstrated in the next section.

2. Project Examples

An example related to digital creativity and design modelling was a project called "Dream Environment". The purpose of this was to allow the students in a 3D



Figure 1. Pikkubots interacting with student avatars

environment to change the building style they are in to study different elements of architecture related to a certain era e.g. in an Egyptian, Chinese, Indian, Roman, Classic style temple or building. The building prototypes would be created then loaded inside a Holodeck (a commercial example of which is “Horizon Holodeck”). The student or tutor can choose whatever environment he wishes for to open up around him from a menu that appears for him inside Second Life. A Pikkubot would then appear, as shown in Figure 1, dressed appropriate to the era chosen and provide information about the architecture and design, asking questions interactively from the student. Other applications of this system can be e.g. to rez a courthouse to conduct forensic studies investigation and role-play.

“Obedient Patient” is another example of a project where bots can be trained as virtual patients, as shown in Figure 2, to give certain responses on being examined in different ways by avatars who belong to medical students training in SL on dealing with patients. This can be held inside an emergency room in a hospital rezzed from a holodeck. Furthermore 3D voice recognition can be used to provide different personalities for the replying bot.

Another example was a project called “Virtual Tourist” using the same technology to teach students about different touristic places on Earth, dangerous places or historical extinct places (could be used by any tourist unable to visit these places due to disability or time) by modeling (simulating) these places e.g. Pyramids, Eiffel tower, Everest Mountain, North Pole, Pacific Ocean, Solar System, placing them in the Holodeck (Figure 3 image 1) then rezzing them at will, with a Pikkubot to explain, provide a virtual tour and question the students. Not only can one build an environment to rez, as can be seen in environments 2 and 3 in Figure 3, but also a real-life panoramic view can be placed in the Holodeck, which would rez around the avatar and create a feeling of immersion inside it (Figure 3 environments 4-8).



Figure 2. Pikkubot posing as virtual patient

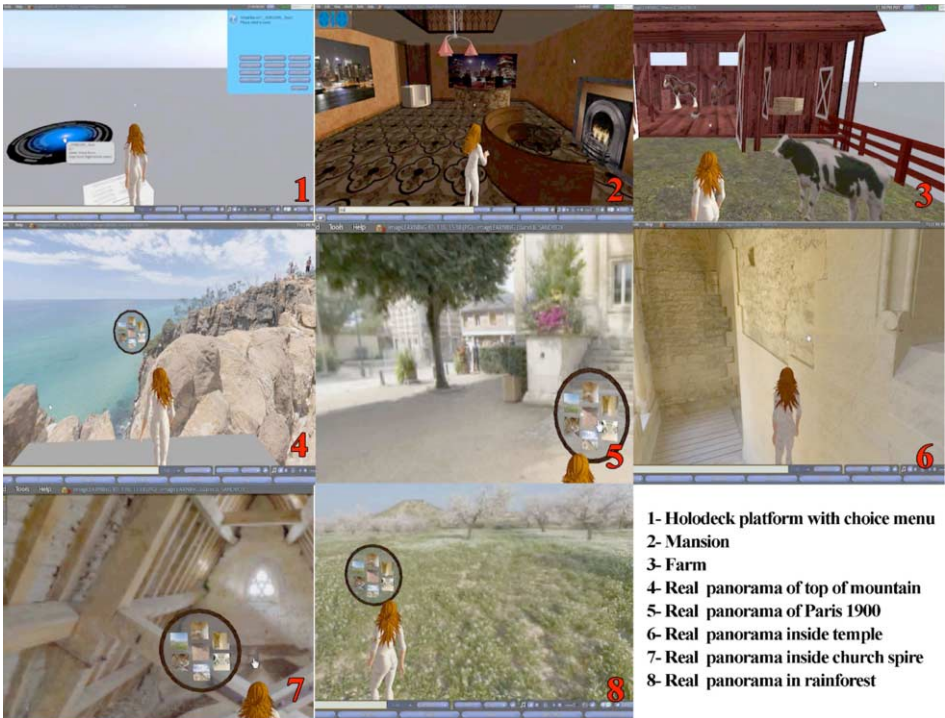

Figure 3. Holodeck and different virtual environments rezzed from inside it using a choice menu

“3D Catalogue” is another interesting project, which appealed to students. It involves creating a complete application for use by a real estate company (houses to buy or rent / hotels to choose from), where the user talks to a Pikkubot (representing an agent). The user specifies the house size he wants, number of rooms, price range

etc., and automatically samples of model house appear before him to choose from (from a holodeck) as can be seen in Figure 4. This has potential of being an online service for a real-life business.



Figure 4. Holodeck rezzing complete buildings for demonstration

“3D Exhibition” is a project similar to the above but displaying a gallery of renowned images for e.g. Monet, Renoir in the Louvre with spoken info by a Pikkubot on each (Figure 5). Another project “3D Interactive Environment” uses the Holodeck to create interactive environments e.g. how to set up alarm system, piping system, precautions in house. Figure 6 illustrates a rezzed kitchen using Holodeck. The frying pan is the Pikkubot asking questions like what to do if a pan was on fire. If you answer correctly it makes a flaring sound, if not the kitchen goes on fire, then you can reset the system again.



Figure 5. Holodeck rezzing an art gallery



Figure 6. Holodeck rezzing an interactive kitchen environment

“Virtual Sensor Simulation” is a final project example, which uses reflexive architecture techniques in SL, which use sensors to identify approach of avatars. This can be used to simulate robotic movement, car crash etc. to help with real-life design of these devices.

The 7 projects described above were piloted with samples of students at random inside Second Life. However their actual impact on under-graduate and post-graduate course remain to be investigated. One point of interest is that According to Maher and Giro [24], agents or bots can function in three modes based on their internal processes: reflexive, reactive, and reflective. Reflexive mode is where the bot responds to sensory data from the environment with a pre-programmed response or reflex without any reasoning. In this mode the bot behaves automatically with no apparent intelligence. Reactive mode is where the agent displays the ability to reason according to the input data such that the bot appears to behave with a limited form of intelligence giving different responses for different situations. Reflective mode is where the bot exhibits capacity to “reflect” on input and propose alternate actions or decisions, i.e. not simply to react but to hypothesize [24]. The projects suggested in this research demonstrate both reflexive and reactive behaviour from the bots, but not reflective. The reflexive aspect can be seen through the Pikkubots’ automatically induced reactions in response to a student’s action. The reactive behaviour can be seen in the interactive solutions or answers offered by the Pandorabot mind attached to the Pikkubot in reaction to a user’s choices or questions. This is reactive because the bot chooses answers or actions from a database, based on its previous training by its programmer. However the presented scenarios here still need to investigate the possibility of creating reflective decision-making AI within the bots.

During their engagement in each project with the bots and holodeck, students were asked to fill in questionnaires in the form of note cards in Second Life to comment and reflect on their experience and interaction. These note cards were then shared with the researcher through a note card giver. An automatic chat log of the participants’

interactions with the bots served as the observation of the interaction that participants had with the bots. This technique was employed as previously utilised by Beaumont et al. [21]. The automatic log of the interaction that every participant had with the bots was analysed, and merits and difficulties recorded to better inform the researcher of the effectiveness of the system and ways to enhance it for future testing with undergraduate and post-graduate courses.

The main merit recognised by the students, as also identified by Muir et al. [25], was that these projects allowed the student avatars to participate in an interactive, engaging "lived experience" that would not be possible in the physical world. They could embody their character, cooperate with others and submerge themselves in an experience that could not be replicated as fully in real-life. Additionally, the free form nature of the Second Life environment meant that each session/lesson could be different, allowing for different situations to be played out depending upon the contributions of the participants. The main drawback however was that students recommended that the system needs some training or orientation before usage as it is not easy or straight forward to use especially for users who are not technologically savvy.

Finally, as claimed earlier, there is sufficient evidence to confirm that the 3D AI virtual projects created in this research satisfy the 7 conditions of constructivism previously mentioned, thus demonstrate usage of constructivism as follows:

1. Providing multiple depictions of reality – through the diverse rezzed environments
2. Focussing on knowledge construction not reproduction – by formation of knowledge through the interaction between bots and users
3. Production of genuine tasks – through innovative ideas created using the bots/holodeck system
4. Providing case-based learning environments – since each project presents a unique case study, situation or environment
5. Promoting reflective activities – through providing critical analysis and reflection on the experience in the form of questionnaires filled by the users
6. Enabling context and content dependent knowledge construction – by programming content specific scripts in the system.
7. Supporting collaborative negotiation – through the engagement of all the students in class in the experience together and contributing to the discussion with the bots

Conclusion

The Artificial Intelligence bot and holodeck system developed in this research shows how 3D virtual worlds can provide environments that can respond automatically and interactively with their users. The diversity of projects created using this system opens endless frontiers for creating student-centred and engaging educational activities to enhance a student's learning experience. As mentioned previously future research

involves enhancing the system, simplifying it and testing it with under-graduate and post-graduate students in Higher Education courses. This is in addition to investigating the possibility of adding reflective behaviour in bot actions to enable decision making to reap most value from technologically supported pedagogy.

References

- [1] J. Kay, *Educational Uses of Second Life* (2009). Retrieved September 3, 2012, from <http://sleducation.wikispaces.com/educationaluses>
- [2] C. M. Calongne, Educational Frontiers: Learning in a Virtual World, *EDUCAUSE Review*, 43(5), (2008), pp. 36-38.
- [3] D. Butler, and J. White, A slice of Second Life: Academics, support staff and students navigating a changing landscape, Hello! Where are you in the landscape of educational technology? *Proceedings ascilite Melbourne*. (2008).
- [4] M. Prenksy, Digital natives, digital immigrants, *On the Horizon*, 9(5), (2001), pp.1–6.
- [5] D. Oblinger and J. Oblinger, Is it age or IT: first steps towards understanding the net generation, In D. Oblinger & J. Oblinger (Eds), *Educating the Net generation* Boulder, CO: EDUCAUSE, (2005), pp. 2.1–2.20.
- [6] X., Wang, P. E., Love, R., Klinc, M. J., Kim, and P. R. Davis, Integration of E-learning 2.0 with Web 2.0. *Journal of Information Technology in Construction (ITcon)*, 17, (2012), pp. 387-396.
- [7] K. Ku and P. S. Mahabaleshwar, Building Interactive Modeling for Construction Education in Virtual Worlds, *Journal of Information Technology in Construction*, 16, (2011), pp. 189-208.
- [8] W. L., Johnson, J. W., Rickel, and J. C. Lester, Animated pedagogical agents: Face-to-face interaction in interactive learning environments. *International Journal of Artificial intelligence in education*, 11(1), (2000), pp. 47-78
- [9] M. A. S., Nunes, L. L., Dihl, L. M., Fraga, C. R., Woszezenki, L., Oliveira, D. J. Francisco, and M. D. G. Notargiacomo, Animated pedagogical agent in the intelligent virtual teaching environment. *Digital Education Review*, 4, (2010), pp. 53-61
- [10] T. A., Mikropoulos, and A. Natsis, Educational virtual environments: A ten-year review of empirical research (1999–2009). *Computers & Education*, 56(3), (2011), pp. 769-780.
- [11] B. Dalgarno, and M. J. W. Lee, What are the learning affordances of 3-D virtual environments?. *British Journal of Educational Technology*, 41, (2010), pp. 10–32.
- [12] D. H. Jonassen, Thinking technology: toward a constructivist design model. *Educational Technology*, 34(4), (1994), pp. 34–37
- [13] M. A. Boudourides, Constructivism, Education, Science, and Technology. *Canadian Journal of Learning and Technology*, 29(3). (2003).
- [14] G. Siemens, Connectivism: A learning theory for the digital age. *International Journal of Instructional Technology and Distance Learning*, 2 (1), (2005).
- [15] J. J. Ham and M. A. Schnabel, Web 2.0 virtual design studio: social networking as facilitator of design education, *Architectural Science Review*, 54(2), (2011), pp. 108-116.
- [16] D. D. Pratt, and Associates, *Five Perspectives on Teaching in Adult and Higher Education*. Malabar, FL: Krieger, Publishers (1998).
- [17] M., Liu, D., Kalk, L. Kinney, and G. Orr, Web 2.0 and its use in higher education from 2007-2009: A review of literature. *International Journal on E-Learning*, 11(2), (2012), pp. 153-179.
- [18] D., Friedman, A., Steed, and M., Slater, Spatial social behavior in second life. In *Intelligent virtual agents*, pp. 252-263. Springer Berlin Heidelberg, (2007).
- [19] M., Varvello, and G. M. Voelker, Second life: a social network of humans and bots. In *Proceedings of the 20th international workshop on Network and operating systems support for digital audio and video*, pp. 9-14, ACM, (2010).
- [20] J., Kemp, and D. Livingstone, Putting a Second Life “metaverse” skin on learning management systems. In *Proceedings of the Second Life education workshop at the Second Life community convention*, pp. 13-18. CA, San Francisco: The University Of Paisley, (2006).
- [21] C., Beaumont, M., Savin-Baden, E., Conradi, and T. Poulton, Evaluating a Second Life Problem-Based Learning (PBL) demonstrator project: what can we learn? *Interactive Learning Environments*, pp.1-17, (2012).
- [22] S., Ranathunga, S., Cranefield, and M. Purvis, *Interfacing a cognitive agent platform with Second Life*, pp. 1-21. Springer Berlin Heidelberg, (2012).

- [23] R., Adobbati, A. N., Marshall, A., Scholer, S., Tejada, G. A., Kaminka, S., Schaffer, and C., Sollitto, Gamebots: A 3D virtual world test-bed for multi-agent research. In *Proceedings of the Second International Workshop on Infrastructure for Agents, MAS, and Scalable MAS*, vol. 5, Montreal, Canada, (2001).
- [24] M. L., Maher, and J. S. Gero, Agent models of 3D virtual worlds. *Proceedings of ACADIA 2002*, (2002).
- [25] T., Muir, J. M., Allen, C. S., Rayner, and B. Cleland, Preparing pre-service teachers for classroom practice in a virtual world: A pilot study using Second Life. *Journal of Interactive Media in Education*, (2013).

Putting the Buzz Back into Computer Science Education

Vic Callaghan^{a,1}, Malcolm Lear^a, Anasol Peña-Rios^a, Victor Zamudio^b, Ping Zheng^c

^a University of Essex, UK

^b Instituto Tecnológico de León, México

^c Canterbury Christ Church University, UK

Abstract This paper describes a rapid-prototyping system, based around a set of modularised electronics, Buzz-Boards, which enable developers to quickly create a wide variety of products ranging from intelligent environments, through robots to smart-phones peripherals to be built and deployed. In this paper we introduce readers to Buzz-Board technology, illustrating its use through three examples, a desktop robot (BuzzBot), a desktop intelligent environment (BuzzBox) and an Internet-of-Things application using a Raspberry Pi adaptor (BuzzBerry). As part of this paper we provide a general overview of Computer Science curriculum developments and explain how Buzz-Boards technology can provide a highly motivating and effective focus for computer science practical assignments. This paper adds to earlier BuzzBoard publications by describing support for Raspberry Pis and intelligent environments, together with reviewing the latest developments in computer science curricula in the USA and UK.

Keywords. Educational Technology, Computer Science Curriculum, Internet-of-Things, Embedded Computing, Buzz-Boards, Intelligent Environments, Robotics, Smart-Phones. ACM-IEEE Curricula, DfE National Curriculum for Computing.

1. Introduction

Enthusing students is the key to engaging students in education. Part of this is providing students with coursework that is relevant to their lives and engages with their imagination and, if possible, creates a general ‘buzz’ in the class. In this paper we discuss this challenge in relation to teaching computer science and present an approach, BuzzBoards, which we believe can be used as a vehicle for simultaneously providing a motivating theme while acting as a teaching tool to illustrate important computing principles. BuzzBoards are a rapid prototyping kit of hardware and software components that enable students and developers to quickly create Internet-of-Things, Pervasive Computing and Intelligent Environments products. In the following section we will introduce the problem we are solving and, by way of comparative examples, describe some other solutions available to educators.

¹ Corresponding author: vic@fortito.com

1.1. Rapid Prototyping kits for education

Computer Science teachers and students face a particular problem in relation to their practical assignments; a shortage of time! Typically, student practical work is organised so students have only a few hours to design, assemble and test a system. Generally that means computer science students have to use pre-designed hardware which limits their scope for creative design. Systems that enable developers (students or professional designers) to quickly create working prototypes are called *rapid prototyping* systems. Buzz-Boards are one such rapid-prototyping system and adopt the principle of utilising modularised plug-together boards in order to enable a wide variety of products to be created quickly, leaving the students more time to focus on creative design elements and programming the systems. For educators wishing to procure tools to support such educational processes, there are a number of systems available, which are described in more detail elsewhere [1] [2] but, for convenience, we now present a précis of the most relevant examples. One of the most widely used prototyping kits is the Arduino system (www.arduino.cc). This is an open-source physical computing platform based on a choice of two processors, ARM and Atmel's ATmega328 microcontrollers. There is a huge user base and a good choice of add-on boards. Programming is an implementation of Wiring which is a Java based platform and IDE (but can be expanded through C++ libraries). The mbed is a rapid prototyping platform developed through collaboration between ARM and Philips which is popular with commercial developers, which supports ARM based product design (<http://mbed.org/>); ARM being the most widely deployed embedded processor in the world being, for example, the processor of choice in smart-phones. It has a practical dual-inline form, allowing it to be plugged into electronic boards in much the same way as an integrated circuit (making it easy to integrate into prototypes). It can be developed in various ways but one attractive option is an online C/C++ compiler and IDE which provides highly productive collaboration support. Again there is a large user base that share software. Finally, there is the Raspberry Pi which is the newest, cheapest and most popular ARM based educational computer kit available, having shipped over a million units in the first 12 months (www.raspberrypi.org). It differs from the majority of bare-board platforms in that its functionality is closer to a data processing computer (ie desktop computer functionality) rather than an embedded computer. As a consequence the RPi IO is somewhat limited. It was originally intended that Python would be its main programming language but the massive RPi user base have ensured it can run numerous OSs and languages.

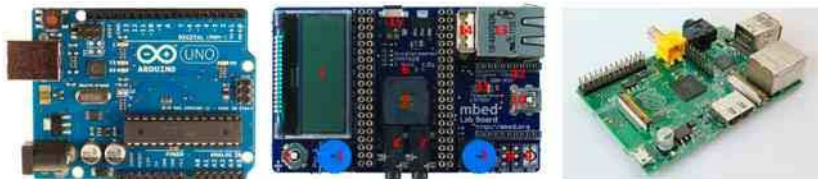

Fig. 1. (left to right): Arduino, mbed and Raspberry PI.

The Arduino, mbed RPi devices are shown in figure 1. A cursory glance reveals they are very different to regular personal computers and, as one might expect from such a bare technological appearance, the architectural functionalities are more obvious and the workings more basic, all of which are used as an educational advantage.

However, these devices and similar systems also have educational shortcomings. For example they frequently need additional hardware to create useful applications, requiring either third part add-ons or a high level of electronic competency to construct the required hardware. While for electronics engineering, there may be advantages in undertaking electronic design, for most computing students, needing to focus on programming, it's a drawback. BuzzBoards overcome these limitations by providing the add-ons these systems need, and offering a flexible plug-and play functionality that makes them simple and quick to use for students. The rest of this paper will examine some of these issues in more detail.

2. Overview of Buzz-Board Technology

2.1. Buzz-Board Markets

As explained earlier, Buzz-boards are primarily a technology for *rapid prototyping* that have applications in a wide range of areas where there is a need to assemble working computer based systems quickly. The primary areas targeted by Buzz-Boards are Education (student assignments), Industry (prototyping) and Maker Activities (arts, crafts & hobbyist). Buzz-boards can be used to create a divers set of applications such as smart-homes, smart phone apps, medical systems, pet-care, toys, internet-of-things gadgets etc. There are over 30 Buzz-Board modules for developers to choose from. Unfortunately, there is not the space to list them in this paper, but they are all listed on the FortiTo website (www.FortiTo.com) and papers [1] [2]. In the following sections we introduce the technology together with some exemplar applications.

2.2. Buzz-Boards

The key principle underpinning Buzz-Boards is modularity (both hardware and software) together with plug-and-play functionality (boards are identified to the system, and to each other, as they are plugged in) based on a common bus (Buzz-Bus). This provides a highly flexible, reconfigurable modular system that can be seen as an ideal infrastructure solution for rapid-prototyping and construction of pervasive and intelligent environments from full scale down to the desktop size environments.

2.2.1. Buzz-Bus

The flexibility of the Buzz-Board system is largely due to the Buzz-Bus board interconnect. Most sensor/affectors and other peripheral devices utilize I²C, SPI, or RS232 serial buses. The Buzz-Bus uses these standards along with general purpose IO to allow Buzz-Boards to be reconfigured and interconnected to create novel products. For example the Buzz-Medi (ECG, EEG or EMG) and Buzz-Sense (humidity, temperature, barometric pressure) boards could be connected to the Buzz-Free (remote IO) to create a product that could log cardiac or muscular activity along with environmental data wirelessly onto a smart phone for later analysis.

2.2.2. Main Processor

The key component of any computing system is the processor. There are, however, a plethora of processors on the market suitable for embedded systems, each with a particular target market in mind. The Buzz-Board system could have adopted a specific processor but this solution would have been at odds with FortiTo's philosophy of flexibility and rapid prototyping without limiting component selection. In addition, FortiTo's marketing strategy is not to compete with existing and popular commercial offerings, but rather to support and augment them. With this in mind a processor agnostic solution was adopted. The main processor board adopted two methods of interfacing a wide range of processors. The first was a 40 pin dil socket designed to accept modules that have little more than a processor on-board, thus keeping cost to a minimum. This socket was based on the already existing mbed processor module thus immediately allowing full mbed compatibility [1]; see the right-hand image in figure 2. This processor agnostic socket links to the main boards Buzz-Bus sockets and on-board OLED display, push buttons, LED's etc. The possibility of remote wireless processing using a smart phone for example can also realized by plugging the Buzz-Free module into this socket. This option will be discussed later in this paper. The second processor interface is a dedicated Raspberry Pi connector; see the left-hand image in figure 2. The Raspberry Pi is a very popular low cost ARM processor board widely used in education. Unfortunately it suffers from limited peripheral IO interfaces, however it does support the I²C and SPI serial buses and with the use of some Buzz interfaces, can be made fully Buzz-Bus compatible.

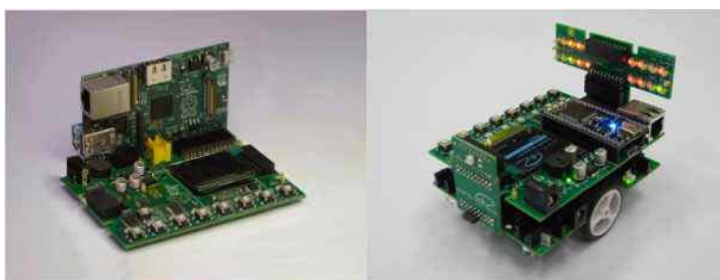

Figure 2: (left to right): Raspberry-Pi BuzzBerry and Buzz-Bot

3. Buzz Applications

3.1. Buzz-Bot – building a desktop robot

Buzz-boards enable the user to assemble them in different combinations; allowing the student to create and develop a wide variety of projects in a very simple ‘plug-and-play’ way. Mobile robots have long been recognized as a highly motivating and thorough way to cover computer science curricula [3] so, in this section, we describe how students can build a desktop robot Buzz-Bot (see Figure 3). The Buzz-Bot can be programmed to perform different tasks such as line following, light seeking, and maze escapes (which are the classic robotic challenges) among others. The Buzz-Bot includes 8 IR Range Finders, 5 line following sensors, 2 light following sensors, Lithium-Ion Battery, 2 dual mode motors, motor load monitoring, quadrature motor

feedback, and USB and external DC charging. This example uses a mbed which can be programmed using C/C++. Programming the Buzz-Bot is very simple, using the online tools and software available on the mbed site. The program is compiled online, generating a .BIN file. The Buzzbed is connected to a PC via a USB (which behaves like a USB pen drive) allowing the user to ‘drag and drop’ the compiled program onto the “pen drive”. Figure 3 shows students from the Instituto Tecnológico de Leon (Mexico) programming and testing the Buzz-Bot as a line follower.



Figure 3. Students programming and testing the Buzz-Bot.

3.2. Buzz-Box – emulating intelligent environments

In simple terms, Intelligent Environments are high-tech environments, filled with numerous networked computers embedded into everyday things we use. Examples include smart -cities, -buildings, -hospitals, factories, -aircraft, -cars, -clothing or even space habitats. They are the forerunners of a new era of digital living where computers will be embedded into most aspects of our lives raising almost limitless possibilities. As such this is “hot topic” in research and teaching. Typically such facilities utilize a full size living space, such as an apartment, equipped with a rich selection of sensors/effectors along with associated embedded processing units. Whilst this approach has many advantages in terms of evaluating real life functionality and practicalities, it does not however lend itself to the classroom scenario involving several students, each requiring exclusive use of the environment. The Buzz-Box (figure 4) addresses this problem by the deconstruction and scaling down of the component parts of the larger environment to create a desktop environment. Key components are the interconnecting 250mm square Buzz-Panels fabricated using PCB material. This construction allows for a selection of essential environmental sensor/effectors to be pre-fitted to a range of panels. The various Buzz-Panels can be connected in any configuration (and size) to create the Buzz-Box using connectors that both mechanically hold the box form and distribute power and data to the sensor/effectors. The panels are manufactured as generic entities, and are then customised to create the specific functionalities illustrated in figure 4. For example, some panels act as the processor host, another might host media services, others a lighting or heating system, another as a controller or status indicator etc.

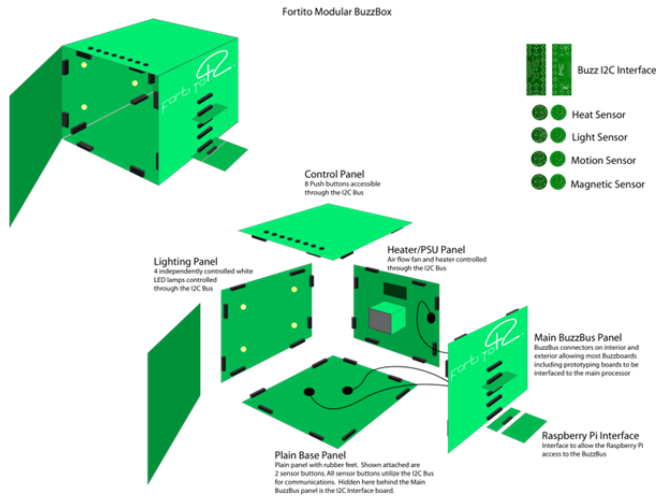

Figure 4 - The Buzz-Box Concept

3.3. Buzz-Free Wireless IO Link

The Buzz-Free wireless IO link (see Fig. 5) offers a new way to connect the processing power of a smart phone, or any computer, directly and wirelessly to hardware. The vision behind this product was to make it easy for smart-phone App developers to create applications to interact with the physical world. The difficulty is, while most embedded processors used inside smart phones have a rich set of peripheral IO interfaces such as I²C, SPI, serial and general purpose IO, these interfaces are usually used exclusively within the phone and are not available for direct connection to the outside world. The FortiTo Buzz-Free system solves this restriction by breaking-out some of these interface to a small module called Buzz-Free. Access and control of the IO from smart phone processor is through a Bluetooth wireless link. The Buzz communication protocol is fast and simple to utilize once a Bluetooth channel is opened up.



Figure 5 - Buzz-Free (Wireless IO) Figure 6 – RPi + BuzzBoards (IoT Application)

For example, if an I²C temperature sensor was connected to the Buzz-Free module, a smart phone could issue a simple ASCII command requesting data from the sensors I²C address. Whilst the Buzz-Free module does have a processor, the protocol and firmware are fixed and the Buzz-Free module can be thought of as an IO breakout for the embedded processor, be it in a smart phone, Raspberry Pi or some other computer.

3.4. BuzzBerry – A RPi Interface for Internet-of-Things applications

The BuzzBerry (RPi hub) [1] is an interface board to the Raspberry Pi (RPi). As was mentioned in the introductions, the RPi is a small low-cost arm GNU/Linux computer which was developed to teach programming and computing fundamentals (<http://www.raspberrypi.org/>). The RPi uses an ARM processor and an SD card as a hard drive and the container of a customised Linux distribution for the device. In terms of peripherals, it allows the use of HD screens with a HDMI video output port and connectivity with an Ethernet port and two USB ports. It also includes RCA video output (for use with analogue televisions) and a 3.5 audio output jack. Finally the RPi includes General Purpose Input Output (GPIO) pins, which allow interfacing it to other devices in the real world. However, the IO is rather difficult to use as it requires a good understanding of electronics to interface to the physical world, which is why we have created the BuzzBerry, as a way to simplify building RPi application that interact with the physical world.

A topical and highly motivating application for students is the *Internet-of-Things*, which in its early years had a variety of names, including the *Embedded-Internet* [4]. Sundmaeker [5] defined the Internet-of-Things (IoT) as “*a dynamic global network infrastructure where physical and virtual “things” have identities, physical attributes, virtual personalities, intelligent interfaces and are seamlessly integrated into the information network*”. This creates smart objects capable of generating and collecting data autonomously using diverse sensors and actuators. In this example we use a mashup between RPi and BuzzBoard toolkit, a combination that allows the implementation of innovative projects by assembling diverse modules/functionalities in various combinations. To facilitate this, BuzzBerry uses RPi’s GPIO pins to interface it with different Buzz-Boards modules allowing the creation of Internet-of-Things (IoT) applications of the students’ choice (fig. 6). Discovery and communication using the Inter-Integrated Circuit bus (I²C) allows the RPi to control a network of devices and permits the wider Internet to be notified which boards are plugged together, identifying board status and services. Mashups between the RPi and BuzzBoard Toolkit can be used in different domains such as; in health by monitoring vital signs in babies or elderly people using the BuzzMedi board, or tracking activity levels combining BuzzNav’s compass and accelerometer with the Global Positioning System (GPS) in BuzzGPS. A different example is the use of the environmental sensors (humidity, temperature and barometric pressure) in BuzzSense to allow remotely monitoring and managing of intelligent environments, which can be applied to energy efficiency or assisted living. An innovative application is the use of BuzzBoards on immersive education and mixed reality laboratories [6], where geographically dispersed students can use immersive technology combined with IoT-based laboratory activities in collaborative learning sessions. The learning activities in these virtual laboratories are based on BuzzBoard modules, which have both real and virtual forms and where components can be created and moved between any of the connected virtual and real worlds. In terms of programming the RPi, the Raspberry Pi Foundation proposes the use of Python, an open-source multiplatform language that has become very popular in the teaching of programming fundamentals (<http://www.python.org>). However it is possible to create programs in other light-weight languages (e.g. C++). To use BuzzBoards with the RPi, the first step is to setup an SD card with RPi’s linux-based operating system. To access BuzzBoard devices a programmer can utilise I²C libraries

that are provided for most popular languages. However, first the programmer will need to identify the I²C address of the BuzzBoards using a command-line function. Finally a program can be written using a text editor and compiled using the console window or created using an open source light-weight IDE (e.g. Geany - <http://www.geany.org/>), generating an executable file (.py - python or an object file for C) that can be invoked on command line.

4. Pedagogy, Computer Science and Buzz-Boards

4.1. Pedagogical Views

The nature of education involves both sides of the learning equation, the acquisition of concepts and theories by the learners and the use of this knowledge in real life situations to solve specific problems. In Computer Science education, the application of this knowledge to real world activities is an essential skill that the learners need to develop, and one of the reasons why educational institutions include laboratory activities in their curriculum programs. These laboratory activities follow the 'learning-by-doing' vision of Problem-based Learning (PBL), a constructivist pedagogy that encourages learners to build on their own knowledge by solving real problems co-creatively [7]. Papert et al. defined that the acquisition of this knowledge is generated by the interaction between knowledge, personal experiences and ideas in active behaviour resulting in the construction of meaningful tangible objects [8].

The application of problem-solving strategies is not limited to academic settings as, emerging technology is encouraging (or maybe requiring) people to adopt more life-long learning behaviours. An interesting example of this is the so-called *hackerspace* or *makerspace*. *Hackerspaces* have been defined as “*physical locations with tools and diverse experts who can help collaborate on projects in a wide range of scales, but it connotes a philosophy of doing things with no particular preference to empirical or theoretical methods*” [9]. One issue in maker and hacker spaces is the availability of suitable prototyping tools, which is an area that Buzz-Boards support. In a similar way, companies utilise rapid prototyping technology to design new products that meet the market requirements. Collins & Halverson [10] suggest that the use of new technologies in learning moved education from apprenticeship (where the student learns through observation and repetitive practice guided by a coach), to didacticism, (classroom-based education where knowledge is transmitted from teacher to student), to the current era where learning involves interacting with a rich technological environment. Buzz-Boards can support learning of these new technologies in both formal settings (universities) and informal (maker or personal spaces). Finally, as most science and engineering is grounded in the physical world, it is especially important, for educators, institutions and policy makers to consider how practical work should be integrated into a modern curriculum.

4.2. Computer Science Curriculums

There is no doubt that computing education is witnessing the need for huge changes to keep up with the evolving skill needs of industry which, in turn, affects computer science curricula. Fortunately, now is an especially timely moment to be considering

computer science curricula as 2013 is the year that the Association of Computing Machinery (ACM) and the Institute of Electrical and Electronic Engineers (IEEE) publish their once-a-decade international curricular guidelines for undergraduate programs in computing [11]. The last complete volume was published in 2001 so the publication of ‘Computer Science Curricula 2013’ allows our discussion to take advantage of the most current insights into computer science curricula. In addition, the UK is currently going through a major metamorphous in pre-university computer education, with the UK Governments’ Education Secretary, Michael Gove, having recently announced (January 2012) the government’s intention to replace the existing ICT curriculum with a more academic Computer Science curriculum [12]. The reasons for this stem from both academia and industry, both of which have been concerned to introduce a computer science curriculum that keeps abreast of the needs of a modern technology based economy. For example, the current Engineering-UK annual report [13], identified that, in order to meet the future UK demand for engineers with Level 4+ skills (top end of pre-University), the UK needs to roughly double its output of students via HEIs and FECs. This assertion was scrutinised by the UK Department of Business, Innovation and Skills (BIS) and has become part of their Industrial Strategy. In support of UK Government policy, the Department for Education released a specification for their new Computer Science Programmes of Study for pre-University school students that was defined in terms of attainment targets which collectively aimed to teach students *“how digital systems work, how they are designed and programmed, and the fundamental principles of information and computation”* [14]. This is still in the process of being implemented so, at the time of writing, there are few clear templates for what the content may look like but, the indications are, it will entail students understanding and using computational abstractions, key algorithms, programming languages (linked to computational problem solving), Boolean logic, hardware and software architecture, networks and some system level work, including the role of specification and evaluation in design (both machine and user).

AL - Algorithms and Complexity	IAS - Information Assurance and Security	PD - Parallel and Distributed Computing
AR - Architecture and Organization	IM - Information Management	PL - Programming Languages
CN - Computational Science	IS - Intelligent Systems	SDF - Software Development Fundamentals
DS - Discrete Structures	NC - Networking and Communications	SE - Software Engineering
GV - Graphics and Visual Computing	OS - Operating Systems	SF - Systems Fundamentals
HCI - Human-Computer Interaction	PBD - Platform-based Development	SP - Social Issues and Professional Practice

Table 1 - ACM-IEEE ‘Computer Science Curricula 2013’ Knowledge Areas

In support of this, the influential UK ‘Computing at School’ Working Group released a report in March 2012, endorsed by such industry giants as Microsoft and Google, that provided a much more detailed interpretation, which identified the key concepts as being Languages, Machine and Computation; Data and Representation; Communication and Coordination; Abstraction and Design; and wider issues such as Intelligence and Ethics etc. [15]. From this it is clear that there is a move towards

invariant principles which is a significant improvement on the earlier situation. As, at the time of writing (May 2013), the UK proposals are a little fluid, so we will focus on the more mature ACM-IEEE 'Computer Science Curricula 2013' [11]. This curricula is organized into a set of 18 Knowledge Areas (KAs), shown in table 1, which correspond to areas of study in computing. The authors go to great length to point out that they would not expect these knowledge areas to translate directly into equivalent courses, but rather that a good degree programme would have these topics integrated across its offerings in a way that suits the particular institution. Clearly this is a wide ranging curricula and the following section will discuss where Buzz-Boards can best support these aims.

4.3. Buzz-Boards and Computer Science

All the above reports argue, a computer science curriculum needs to be supported by substantial body of theoretical and practical knowledge. Buzz-Boards provide a practical means to implement the theory. Moreover the UK DfE stresses the importance of creative processes and projects, which the versatile system composition method employed in Buzz-Boards supports (reconfiguration via re-plugging). In more concrete computer science terms, Buzz-Boards are networked processors with a rich set of IO. Because the hardware structure is highly visible, through the process of plugging in functional units, the architecture principles are made more evident to students. The processors run an OS which can be programmed at various levels, from machine code through high-level languages such as C++ to end-user programming. Clearly there is not sufficient space to go through the ACM-IEEE Knowledge Areas, item by item, but even a cursory glance quickly reveals it would be difficult to find an area that Buzz-Boards could not support. To give just a few examples of how the ACM-IEEE curricula (see Table 1) might be supported by Buzz-Boards, AR and SF can be illustrated using the highly modularised architectural functionalities of Buzz-Boards; OS, SDF, PL, might be supported using the rich variety of programming environments afforded by Buzz-Boards; AL can be supported via the rich set of Buzz-Board sensors which provide huge opportunities for algorithms; the wide set of communications supported by Buzz-Boards, such as IP, Bluetooth, WiFi and I²C, provide good mechanisms for NC. Beyond the basic Buzz-Board functionalities there are a huge variety of applications they can be used to illustrate. Some popular topics are the Internet-of-Things, Pervasive Computing and Intelligent Environments. All these topics are characterised by intensive use of networks, distributed computing and real-time operation. Clearly choosing application areas is also an important consideration both to support the underlying computer science and open the door to a longer term job market.

5. Buzz-Boards Value Proposition & Relevance to Wider Business

This paper has discussed the educational value of Buzz-boards in a university context explaining how they can perform as an effective pedagogical tool for teaching by meeting the needs of modern curricula and promoting an action-oriented learning environment to nurture future innovation. Undoubtedly Buzz-Boards can be recognised as the muse to inspire individuals and engineers to develop their creative ability in

computing science. However, the potential values of Buzz-Boards are far more than its application to university education, as it has substantial commercial value both as a rapid-prototyping system for ICT industries worldwide, together with some potential to service a rapidly growing consumer market for educational toys and smart-phone apps (to give just some examples). Value creation can be defined from different perspectives using strategy and organisation behaviour literature; marketing and economics; or entrepreneurship theory. The core of the value creation process, regards it as adding value to market offerings of the customer, the wealth creation of the business organisation and advancement to the industries [16] [17]. Buzz-Boards can directly contribute to a manufacturers value creation by enabling them to generate prototypes of their product ideas quickly (quicker than other methods, and their competitors). In addition, the use of effective IT tools and computer AI can result in radical changes on how work is performed and managed (see case study evidence from Zheng [18]). In education it enables institutions to offer more attractive and effective options to students and staff, improving their image and impacting on their revenue generation.

We now live in a digital world with interconnected networks where embedded computing is all pervasive. The concept of Buzz-Boards has captured this emerging trend and can be further developed into a series of portfolio products serving different emergent market gaps. For instance, Buzz-free can be applied to various types of electronic consumer goods, such as smart phones for mass consumer market and BuzzBerry can support the RPi market which has massive educational and hobbyist user groups. In the long run, Buzz applications can create multiple commercial values in a more complex business environment for both B2C (business to consumer) and B2B (business to business) markets. Needless to say Buzz-Boards are full of unique and exploratory added values that have great potential to add value to a number of enterprises, especially the education market that this paper addresses.

6. Summary

In this paper we have addressed the issue of how new computer application paradigms such as the Internet-of-Things, Pervasive Computing and Intelligent Environments can be harnessed to form a highly motivating theme for teaching the latest computer science curricula. To enable this we have introduced a modular computer science laboratory kit, BuzzBoards that enables students to build a variety of products and environments, of their own design. We also explained how BuzzBoards are processor agnostic and can work with virtually any processor or system. We illustrated the potential for BuzzBoards using three examples starting with a desktop Robot (BuzzBot) assembled from a mbed ARM based processor. Robots are popular with students and have been used widely to illustrate most computer science principles, such hardware, IO, OS programming, data structures, communication and AI. We then described how a desktop intelligent environment could be built (BuzzBox) that enabled students to experiment with building, for example, smart-homes or pet-care applications. Finally, we discussed how BuzzBoards can support experimentation with the Internet-of-Things using a Raspberry Pi. In addition we highlighted our latest member of the Buzz-Board range, Buzz-Free, which is a board that enables connections to any Blue Tooth device, such as a smart-phone, enabling students to create innovative Apps that interact with the real world. While the BuzzBoard range of over 30 boards can be used for rapid prototyping of new products in companies, its roots lie in

education and we therefore concluded the paper with a discussion on pedagogies and computer science curricula to show how these products might support computer science teaching. Finally, to further reinforce that discussion, we ended by presenting the value proposition that Buzz-Boards represent. More information is given in the cited references and on the BuzzBoards website www.FortiTo.com. The aim of the BuzzBoard range is not just to provide the most versatile educational technology kit for teaching computer science, but also to be the most creative and motivating approach, with the hope that, with your help, we can “Put the Buzz Back into Computer Science Education”.

References

- [1] V. Callaghan, “Buzz-Boarding: Practical Support For Teaching Computing, Based On The Internet-Of-Things”, 1st Annual Conference on the Aiming for Excellence in STEM Learning and Teaching, Imperial College, London & The Royal Geographical Society, 12-13 April 2012
- [2] M. Wang, V. Callaghan, M. Lear, M. Colley “Teaching Next Generation Computing Skills; The Challenge of Embedded Computing”, Intelligent Campus 2011 (iC’11), Nottingham 26th July 2011
- [3] V. Callaghan, R. McCarthy (eds), “Introduction To Robotics In Computer Science And Engineering Education”, Special Issue of Journal of Computer Science Education, Vol 7, Issue 2, JAI Press, 1996
- [4] J. Chin, V. Callaghan, ‘Embedded-Internet Devices: A Means of Realising the Pervasive Computing Vision’, Proceedings of the IADIS International Conference WWW/Internet 2003, ICWI 2003, Algarve Portugal, 2003
- [5] H. Sundmaeker, P. Guillemin, P. Friess, S. Woelfflé, “Vision and Challenges for Realising the Internet of Things”, Cluster of European Research Projects on the Internet-of-Things (CERP-IoT) - European Commission, 2010.
- [6] A. Peña-Ríos, V. Callaghan, M. Gardner, M. J. Alhaddad, “Remote mixed reality collaborative laboratory activities: Learning activities within the InterReality Portal” on Web Intelligence and Intelligent Agent Technology (WI-IAT), 2012 IEEE/WIC/ACM International Conferences - The Intelligent Campus International Symposium (IC’12), vol.3, no., pp.362,366, 4-7, Macau, China, 2012.
- [7] K. Ngeow, Y. Kong. “Learning to learn: Preparing teachers and students for problem-based learning” [ERIC digest] 2001.
- [8] S. Papert, I. Harel, “Constructionism”, Ablex Publishing Corporation, 1991
- [9] M. Altman, “Founding a Hackerspace: An Interactive Qualifying Project Report”. (Interview). 2010.
- [10] A. Collins. R. Halverson. “Rethinking Education in the Age of Technology: The Digital Revolution and the Schools”. Distance Education, (fall), p.1-11. 2009. Available at: http://mit.kku.edu.sa/courses/media-arts-and-sciences/mas-714j-technologies-for-creative-learning-fall-2009/readings/MITMAS_714JF09_read03_coll.pdf
- [11] ACM-IEEE, “Computer Science Curricula 2013”, Ironman Draft (Version 1.0), The Joint Task Force on Computing Curricula (ACM & IEEE-Computer Society) February 2013.
- [12] M. Gove “Harmful’ ICT curriculum set to be dropped to make way for rigorous computer science”, Press release, Rt Hon Michael Gove MP ‘UK Department for Education (DfE), 11 January 2012
- [13] EngineeringUK, “Engineering UK 2012: The state of engineering” (a report), Weston House, 246 High Holborn, London WC1V 7EX, www.EngineeringUK.com
- [14] DfE, “Computing: Programmes of study for Key Stages 1-4”, Dept for Education, February 2013
- [15] CAS, “Computer Science: A curriculum for schools” Computing at School Working Group, <http://www.computingschool.org.uk>, March 2012
- [16] D. F. Kuratko, R. M. Hodgetts, 7th ed., “Entrepreneurship: Theory, Process, Practice”, Thomson South-Western, Mason, USA, 2007.
- [17] P. Burn, *Entrepreneurship and Small Business: start-up, growth and maturity*, 3rd ed., Palgrave Macmillan, Basingstoke, UK, 2001.
- [18] P. Zheng, “Entrepreneurial Growth and Ownership under Market Socialism in China - a longitudinal study of small business growth”, *Journal of General Management*, Vol. 38, No. 2, Winter 2013

Towards Adjustable Autonomy in Adaptive Course Sequencing

Abdulkareem ALZHRANI ^{a,1}, Vic CALLAGHAN ^a and Michael GARDNER ^a
^a*Department of Computer Science, University of Essex, UK.*

Abstract. This paper presents adjustable autonomy and its application in adaptive course sequencing. The research aims to explore an adaptive course sequencing system (ACSS) which adapts the sequence of learning objects based on the student's profile and learning behaviour using soft computing techniques. The main contribution of this research is to make ACSS user driven by equipping it with adjustable autonomy mechanisms which allows student, tutor or some automated process to set the desired level of autonomous guidance. In addition, the system enables the teacher to reedit the sequence/guidance rules. Hence, we believe that a student will learn better when he/she learn using such a system, a hypothesis the longer term work of this student will seek to confirm. This paper gives an overview of the research area and presents an initial conceptual model which describes the ACSS's units and the relationship between these units.

Keywords. Adaptive course sequencing, intelligent tutoring system, adaptive educational hypermedia system

Introduction

Sequencing learning objects in intelligent tutoring system is one of a teacher's or instructor's responsibilities. Hence, he/she has to provide the domain model together with rules needed by the tutoring model to guide a student through a sequence of learning objects. However, this method is not sufficiently adaptive and personalized for individual students.

Therefore, we are proposing a new approach which we have named the Adaptive Course Sequencing System (ACSS). ACSS neither provides a fixed sequence of learning objects nor requires the teacher to dictate the rules for the guidance. Instead, it uses soft computing techniques to build an adaptive and dynamic sequence. This is done by offering number of learning objects and allowing the student to choose the learning objects he/she prefers to learn. ACSS then observes the student's learning behaviour and builds a profile for the student. The profile is then analyzed and informs a personalised tutoring agent so it can act as a sequence learning guide, suggesting the most appropriate learning path through a palette of learning objects.

By achieving that, we believe that students, particularly mature learners will learn better. However, as in real life, learners require differing levels of support a need we address by providing an adjustable autonomy tutor (i.e. an agent that can have the amount of help it provides adjustable). The amount of help a learner needs depends on

¹ Corresponding Author: Abdulkareem Alzahrani, School of Computer Science & Electronic Engineering, University of Essex, Wivenhoe Park, Colchester, CO4 3SQ, UK; E-mail: aalzaa@essex.ac.uk

numerous factors such as their previous knowledge of the subject, the quality and teaching style of the current learning object and even how the student feels on that particular day. Therefore, equipping intelligent tutoring system with the adjustable autonomy mechanisms will make the system more adaptable and dynamic to the numerous variables that characterise the particular learning needs of a student. In addition, it will allow the learner or tutor to have the control and choose the preferred level of autonomy which in turns leads to learning better.

The main aim of this research is to devise an adaptive course sequencing system (ACSS) which learns students' needs and provides an adjustable level of support in guiding them through a set of learning object. This involves exploring the need for adjustable autonomy in ACSS and the ways of enabling adjustable autonomy in ACSS.

1. Related work

1.1. Intelligent Tutoring Systems

Intelligent Tutoring Systems (ITS) are computer-based learning systems which attempt to adapt to the needs of learners [1]. It operates by facilitating ITS components (domain, student, tutoring, and user interface models) to interact so as to achieve various leaning and knowledge acquisitions[2]. In addition, ITS is the only part of the general IT and educational research which seeks, its scientific goals, to make computationally precise and explicit, forms of educational, psychological and social knowledge, which are more often left implicit" [1]. The following sections describe the ITS components (domain, student, tutoring, and user interface models) in more detail:

1.1.1. Domain model

This represents information about specific problems. It includes entities, definitions, processes, skills, and relations. In some problems it defines how experts should perform in a given domain, such as how to administer medications for disease [3], generate algebraic equations [4], or multiply numbers [5], to give but sum examples. There are three popular approaches for representing and reasoning domain knowledge which are; rule-based models, constraint-based models, and expert models.

1.1.2. Student Model

This represents the level of a student's conceptual understanding of a domain and describes how to reason about the student's knowledge of the domain. In its specific meaning, it contains information regarding a typical student's domain skill (stereotypic) and the information about current students. Examples of the latter include possible misconceptions about a domain, time spent on particular problem, the hints requested during learning, and the preferred presentation and learning style. [6].

1.1.3. Tutoring Model

This model comprises the series of decisions that should be implemented to identify a representation plus a descriptive assessment of the learning of knowledge, skills, and competencies. [8]

Woolf (2010) is of the view that tutoring models represents teaching strategies. This includes methods for encoding reasoning about the feedback from initial processing. Such encodings can be derived from empirical observation of teachers informed by learning theories, or enabled by technology, thus being only weakly related to a human analogue (simulations, animated characters).

1.1.4. Communication model

This model represents methods adopted for communicating between the students and computers. Examples of devices and processes used in communication models are graphical I/O interfaces, animated agents, and other dialogue mechanisms. Typical communication includes graphical illustrations, managing communication, and discussing student reasoning [2].

1.2. Adjustable Autonomy

Adjustable autonomy emerges from the underlying concept of agent autonomy which centres on building sets of actions, the relationship between the actions, respective scopes of each action, and the associated logical constraints governing the actions [9].

As identified by Bradshaw et-al. [9], a major challenge in adjustable autonomy is the requirement that the degree of autonomy is continuously and transparently consistent with declared policies ideally imposed and removed appropriately as desired. Bradshaw et-al also introduced the concept of a “sweet spot”. According to this concept, an autonomous system is governed in a way that balances the convenience to delegate work with the assurance that delegating such work to a trusted system results in a minimum risk of failure.

Recently, a project [10], [11] at the University of Essex designed and built a smart home adjustable autonomy system which sought to collaborate with users to manage common tasks in homes.

In this project, Ball and Callaghan [10], [14] categorize four level of adjustable autonomy as being, full, high, low, and NO autonomy. In ‘full autonomy’ the agent manages the environment without user assistance. To do this it monitors the user’s habitual behaviour creating rules (learning) that it uses to pre-emptively set the environment to a state it believes will match the user’s needs. High-Semi-autonomous offer a mix of user and agent control which is commonly termed mixed initiative interaction. It is similar to fully-autonomous operation except that it requires the user to confirm automatically generated rules. This way, users can accept, reject, or edit the rules generated by the agent. Low- semi-autonomous uses the same mixed initiative interaction but uses an approach whereby the user offered suggestions by agent as an aid to generating behavioural rules. Finally, ‘no autonomy’ is similar to low autonomy with the added difference that, the user generates the rules without any assistance from an agent. The Essex work is rooted in Chin’s end user programming research [13] and Hagaras’ fuzzy logic agents [12].

Various survey results indicate the usefulness of adjustable autonomy management system for intelligent environments. Differences in styles, user preference, trust, and dynamic control of autonomy level constitute the major findings as reported by many researchers [14]. A typical finding in these surveys is that people prefer higher level of

control over personal systems such as entertainment and lower level of control over systems such as heating and lighting that are not associated with a particular user experience and perception. We hypothesise that this desire for personal control will extend to personalised learning.

2. Fictional Discussion to Illustrate Rationale

“Smith is a University lecturer and he teaches a Software Engineering Module. Smith has been asked to use an online educational system to be used by students as a support tool, accessing the system in their own time. However, Smith said he had a bad experience with an online educational system. He said it had taken a long time to create the learning design scheme, particularly the guidance rules that are used for sequencing learning objects, which added greatly to the load on him. Therefore, he asked if there is an alternative way to determine and program the sequence of the learning objects. In addition, Smith said that he asked some students about their preferences regarding the online educational system. He found that some students asked more freedom in terms of choosing which learning objects would be studied. Those students argued that some learning objects in the system might be known before and if they are forced to study them again this would negatively affect their motivation towards the module. In other words, those students said they wanted the sequence of learning objects to be more flexible to allow them study only the learning objects they needed. Other students added that if the system could recommend the most appropriate learning path they should follow, that would improve their learning experience.”

From that story, we can advise Smith and his students to use the Adaptive Course Sequencing System (ACSS). ACSS is a web-based system which is capable of profiling its users and suggesting appropriate learning path based on their profile. The teacher is not required to provide ACSS with the sequence of the learning objects and their conditions, which are used for the guidance. Alternatively, ACSS uses the soft computing techniques to predict the most appropriate learning path for every student based on his/her profile.

ACSS has node-based interface which allows students to choose the learning objects they would like to learn. In addition, every node in this interface represents one learning object and contains introduction, explanations and multiple-answer questions (i.e. formative assessment). The student can read a node's introduction by hovering over the node with a mouse. Every node has one of three colours (blue: the student hasn't opened this node yet, green: the student has achieved the relevant learning objective and Red: means the student could not answer the questions in this node).

Every interaction between student and ACSS is recorded in student profile as well as some information about the student (e.g. his/her gender, age and level of knowledge ...etc.). Once enough information is gathered about a student, ACSS, using soft computing techniques, analyses student profiles and observes the patterns of the sequences that students have made in order to generate guidance rules. Subsequently, ACSS uses these rules to build a tutor model.

The tutor model contains sets of rules which are generated and refined over the time by reasoning on student profiles. Each rule, when created, is assigned a value

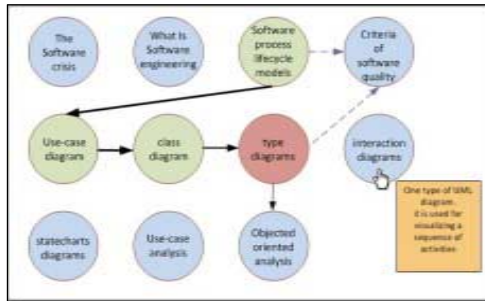

Figure 1. The node-based interface in ACSS

between 0 and 1 as a level of confidence. The value of the confidence level increases over the time based on who the repetition of the actions that make the rule. Rules that have high confidence level are stored as ‘Active Rules’ whereas other rules are stored as ‘Potential Rules’. Both sets are part of the tutor model.

On the other hand, ACSS is trained by teaching a number of students (*software engineering*) and each lesson will have a number of learning objects with no sequencing between them. After the ACSS is trained sufficiently, it has got affective student profiles and tutor model. Hence, ACSS can present appropriate learning paths for students’ based on their profile and experiences of other similar students. In addition, the most appropriate learning path for the student will be presented in bold solid black colour line and the alternative path will be presented in dashed grey colour.

2.1. The need of adjustable autonomy in ACSS

2.1.1. An Illustrative Scenario

“Sarah, Jane and David are learning using ACSS and they meet their teacher (Smith) to discuss the benefit of this system. Sarah said, she does not like the node-based interface (module map) in ACSS. She said that she is hesitant and the presentation of the nodes and the learning paths made her confused which, in-turn, affected her learning progress. She selected the option whereby ACSS would choose the most appropriate learning path for her and force her to follow it without giving her the ability to skip any learning object. In contrast, Jane said that the presentation of the learning paths ACSS performs (as shown in **Figure 1**) is absolutely convenient for her and she loves it. David said he likes the freedom he is given by ACSS for jumping between learning objects but he does not want any kind of recommendation or guidance from ACSS. In other words, he asked to keep the presentation of the learning objects’ nodes as it is shown in **Figure 1** but without it making suggestions as to his learning path.

Smith (the teacher) asked if there is a way allowing him to access the tutor model to dictate and edit the rules.”

From this story, it can be said that the best way to make ACSS user-driven is by implementing the mechanisms of Adjustable Autonomy. By doing this, every student can choose from various levels of autonomy as described in this table:

Table 1. The levels of adjustable autonomy in ACSS

Autonomy Level	Description
Full autonomy (3)	The tutor model agent takes guidance responsibility and guides the student from learning object to another without using the node-based interface.
Partial autonomy (2)	Students can choose their own sequence from the module map. In addition, ACSS presents the appropriate learning paths and recommends one of them.
No autonomy (1)	Students can choose their own sequence from the module map. The ACSS will not recommend the best learning path.
Instructor Programmed	The teacher can access the tutor model and dictate new rules or edit the existent rules.

After adjusting the autonomy of the tutor agent in ACSS, Sarah is then forced by ACSS to follow the most appropriate learning path for her. ACSS guides her from learning object to another depend on her profile. In addition, Sarah does not need to deal with the node-based interface.

For Jane, who prefers the partial autonomy level, ACSS will continue acting as before and she will not recognize any change.

For David who prefers the no autonomy level, the ACSS does not present the recommended learning paths. He is free to choose the learning objects he would like to learn from the module map (as before).

Smith (the teacher), can then access the tutor model and write or edit the rules. In addition, he can reset the level of confidence for any rules.

3. ACSS Conceptual Model

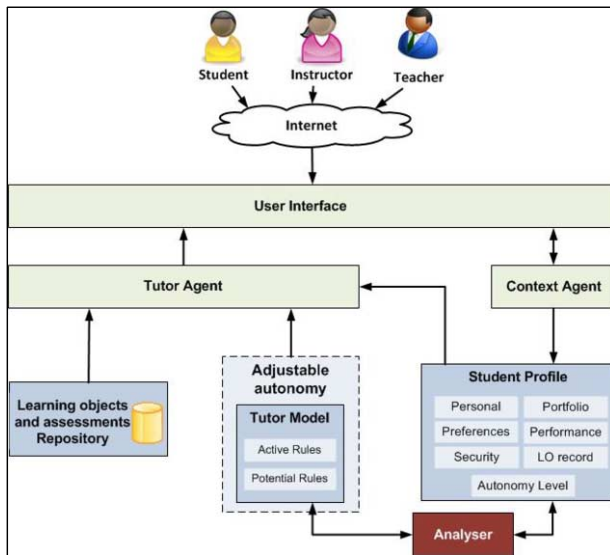

Figure 2. ACSS Conceptual Model

Using the earlier scenario, we have proposed this conceptual model as a way of delivering the required functionality. From the student’s perspective, this model is able

to give students' the freedom to choose a path through learning objects as well as recommend appropriate learning paths. In addition, it gives the student the ability to choose the guidance method (e.g. enforce, recommend or no guidance). On the other hand, the teacher/instructor can set the guidance rules simply and the learning objects as well.

The model is divided into the following main parts: communication, user interface, tutor-agent, context-agent, Analyzer, LO and assessments repository, student profile, the tutor model and adjustable autonomy mechanism which are briefly described in the following sections.

3.1. The communication

ACSS is a web-based application. Therefore, the learner uses the internet network to access ACSS.

3.2. User Interface

ACSS has a node-based interface. That means every learning object will be presented as a node, as previously described in the scenario. This interface will be presented to a student who chooses one of these levels of autonomy namely: No autonomy (1) or partial autonomy (2) or full-autonomy. However, the difference between these levels in terms of the interface is that the module map will be presented for student who chooses the partial autonomy level. In addition, a student who chooses the full autonomy level will simply be presented with learning objects to complete (not the node-based interface or the module map). Technically, the development of the node based and module map interface is being developed using Python and JavaScript (D3.js).

The teachers/instructors have a different user interface which allows them to access the tutor model and set the learning sequence rules manually.

3.3. Tutor Agent

This agent manages the entire process. When a student starts using the ACSS, the tutor agent will request student profile for this student. If there is no information about the student's knowledge level, the tutor agent will generate a formative assessment (taken from the assessment repository) and ask the student to undertake it, storing the result in the student profile. However, if the student has already done the formative assessment, the tutor-agent will request some relevant information from student profile (i.e. student's preferences and performance) which is uses to request the related rules from the tutor model. In addition, the tutor-agent takes into consideration the chosen autonomy level and, based on that, the tutor-agent will chose the guidance method as described in section 2.

When the student finishes studying a learning object, the tutor-agent will request the relevant assessment from the repository to test the student and then store the marks in the student profile.

3.4. Context Agent

This agent is responsible for observing student learning behaviour and store the information in the student profile.

3.5. Analyzer

This is the main component that provides the ACSS with intelligent behaviour based on the use of fuzzy logic to generate rules which are subsequently analysed by a reasoning engine operating on the student profiles.

3.6. Learning Objects and Assessments Repository

This component is responsible for storing learning objects with their information. This information includes the title, description, main content (i.e. explanations) and multiple-answer questions (i.e. formative assessment). In addition, the teacher can access the repository to add, delete or edit any learning object.

3.7. Student Profile

This component uses a database to store the student's personal information (e.g. name, age and email...etc.) and the student's learning information (e.g. completed learning tasks and time on tasks....etc.). In addition, this component follows, partially, the enhancement of IEEE-PAPI specification that was made by Wei and Yan [15]. Thus, this component has these categories:

- Personal information: <name, telephone, address, reference, e-mail, post address>
- Portfolio information: <knowledge level, degree, transcription, qualifications, certificates, licenses>.
- Security information: <user name, password>
- Preference information: <language, region, age level, input/output device preference, content preference, prefer time on each study>.
- Performance information: <learner ID, content ID, recoding-date-time (time begin, time end), complete percentage, score>.
- Learning objects record <learning object ID >.
- Autonomy level: <level of autonomy>.

3.8. Tutor Model

The tutor model contains rules to be used by the tutor-agent. In addition, the rules in tutor model are classified into two components; Active rules component and potential rules component.

The active rules component stores the rules that have high confidence level (initially more than 0.75 of 1.00). Whereas, the potential rules component stores the low level confidence rules.

These rules will be readable (thanks to fuzzy logic rule sets). Below is an initial view of the active rules component.

Table 2. Example of the active rule component

Rule	Confidence Level
If the previous domain knowledge is poor AND the learning object A mark is good AND the learning object C mark is bad THEN next learning object is B.	0.78

3.9. Adjustable Autonomy

This component offers three choices of autonomy for student and gives the teacher the ability to add, delete and edit the rules in the tutor model (as explained in section 1.1). It can give suggestions for rules to aid the teacher.

4. Experimental work to date

In this section, we summarise the work to date.

4.1. Learning Design (LD)

Using LAMS, we have structured the evaluation scenario for the learning phase. Firstly, the student will be forced by the system to do a formative assessment. Then, the student will be able to choose one of the learning objects. Every learning object is designed to have an introduction, explanation and multiple questions to assess the student’s performance in that learning object. By the end of this process, the student will have been completed an assessment and survey which, in addition to supporting the system operation, will provide an experimental record and data.

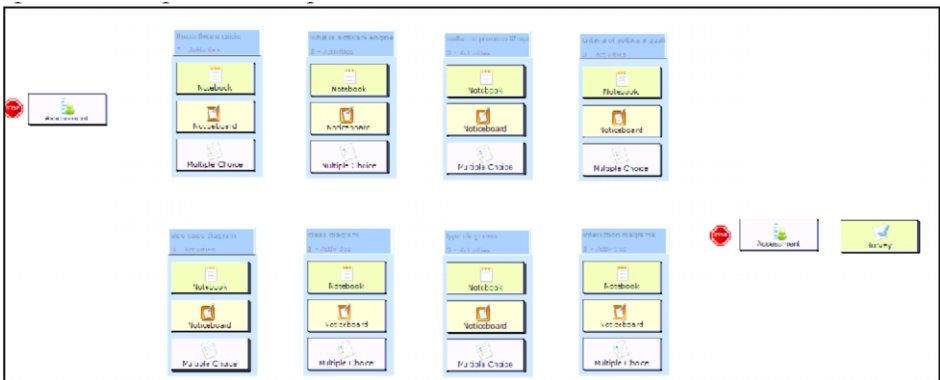

Figure 3. Learning design first lesson using LAMS

4.2. Student profile

Using PostgreSQL we have designed and built a student profile scheme. As mentioned earlier in section 3.7 the student profile will follow IEEE PAPI. **Figure 4** shows the seven tables with the relations between them, that comprises this profile.

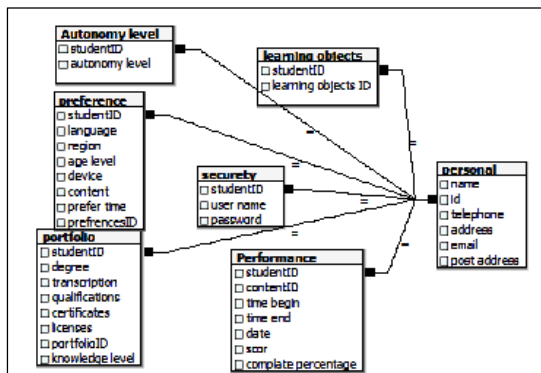

Figure 4. The initialized student profile

5. Future work

We are now entering the experimental phases of the research. The first phase will investigate the students' learning needs and preferences regarding adaptive course sequencing in general and adjustable autonomy in particular. Therefore, a questionnaire will be distributed and analyzed to partially contribute in achieving these research objectives; 1) *understanding the student's learning needs and preferences*, 2) *studying the need for adjustable autonomy in adaptive course sequencing*.

The second phase will involve exploring the chosen topic (*Software Engineering*) might be implemented as a practical test of ACSS. This will involve choosing number of lessons, constructing the related learning objects and constructing the formative and summative assessments from those lessons.

In the third phase, a web-based adaptive course sequencing will be built. This will involve mapping the subject space to learning objects, initializing student profile, developing the observation mechanisms to observe student doing learning, building tutor model and implementing the soft computing techniques needed for reasoning student profile to enrich the tutor model. By doing this phase, the question "*How do we encode the learning experiences in fuzzy rules?*" will be answered.

The fourth phase, will refine and implement the conceptual architecture model for the adjustable autonomy as part of a broader intelligent educational environment (AAIEE). In addition, this phase will involve defining how adjustable autonomy can be designed and what the steps are needed for this design in educational context. In completing this phase we aim to answer the question "*How best can adjustable autonomy be enabled in adaptive course sequencing system*". Moreover, we will also answer the question (*Does adjustable autonomy intelligent tutoring system brings significant benefits to student learning?*).

The fifth phase is the training phase which involves teaching a number of student's lessons (*in software engineering*) with each lesson having a number of learning objects. By doing this phase, we will answer the question "how much training is required".

The sixth phase is the evaluation phase which involves teaching students the same lessons and assessing their behaviour and progress. This phase consists: 1) Equipping the system with adjustable autonomy mechanisms; 2) Evaluating the guidance in the system by giving the students summative assessments after they finished every lesson (and comparing their marks with students studying similar lessons but in fixed sequencing method); 3) Using interviews to provide a qualitative assessment of student satisfaction towards the adjustable autonomy together with a more quantitative comparison of students' marks from every level of autonomy. Another area of evaluation is will be to analyze the usage of ACSS based on the data gathered from the behaviour of the adjustable autonomy. By doing these phases, we will be able to answer the question "*What are the benefits of adjustable autonomy and adaptive course sequencing to students*". Moreover, we hope to answer many more research questions as part of this work.

6. Conclusion

This paper describes early stage research that is setting out to investigate how adjustable autonomy might be applied to sequencing learning objects to empower students to personalise better their learning experiences. Our research objects concern both the technical possibilities as well as the learning benefits, so we will be evaluating this work using real students and lessons. The work itself is an early stage and we believe that the main contributions of this paper are a through literature the rational for applying adjust able autonomy to education and, most importantly, a conceptual model (the ACSS) for how this might be implemented. The proposed model implements the adjustable autonomous agent as part of an intelligent pedagogical tutoring system. The level of guidance can be adjusted autonomously to cater for the need of the pupil. The adjustment can be carried out by the teacher, the pupil, or the machine based preference of educational stakeholder's policies (E.g. curricula) and the pedagogical needs of the target pupil. This type of intelligent environment is important as it closely reflects the actual teaching environment where the teacher alters the level of help or guidance a pupil receives based on their capabilities and immediate needs. Adding a more naturalistic view to alter the autonomy provided by such system will, we hope, have a positive impact on learning systems. We suggest that this adds a more dynamic adaptability to supporting the role of teachers' and needs and progressions of learners using online systems.

References

- [1] J. Self, "The defining characteristics of intelligent tutoring systems research: ITSs care, precisely," *International Journal of Artificial Intelligence in Education (IJAIED)*, vol. 10, pp. 350–364, 1998.
- [2] B. . Woolf, *Building Intelligent Interactive Tutors: Student-centered strategies for revolutionizing e-learning*. Morgan Kaufmann, 2010.
- [3] C. R. Eliot, K. A. Williams, and B. P. Woolf, "An intelligent learning environment for advanced cardiac life support.," in *Proceedings of the AMLA annual fall symposium*, 1996, p. 7.

- [4] A. Corbett, "Cognitive tutor algebra I: Adaptive student modeling in widespread classroom use," in *Technology and Assessment: Thinking Ahead. Proceedings from a Workshop. National Academy Press, Washington*, 2002.
- [5] I. Arroyo, J. E. Beck, B. P. Woolf, C. R. Beal, and K. Schultz, "Macro-adapting Animalwatch to Gender and Cognitive Differences with Respect to Hint Interactivity and Symbolism," in *Intelligent Tutoring Systems*, G. Gauthier, C. Frasson, and K. VanLehn, Eds. Springer Berlin Heidelberg, 2000, pp. 574–583.
- [6] Y. Zhou and M. W. Evens, "A practical student model in an intelligent tutoring system," in *11th IEEE International Conference on Tools with Artificial Intelligence, 1999. Proceedings*, 1999, pp. 13–18.
- [7] A. S. Drigas, K. Argyri, and J. Vrettaros, "Decade Review (1999-2009): Artificial Intelligence Techniques in Student Modeling," in *Best Practices for the Knowledge Society. Knowledge, Learning, Development and Technology for All*, M. D. Lytras, P. O. de Pablos, E. Damiani, D. Avison, A. Naeve, and D. G. Horner, Eds. Springer Berlin Heidelberg, 2009, pp. 552–564.
- [8] J. Bourdeau and M. Grandbastien, "Modeling Tutoring Knowledge," in *Advances in Intelligent Tutoring Systems*, R. Nkambou, J. Bourdeau, and R. Mizoguchi, Eds. Springer Berlin Heidelberg, 2010, pp. 123–143.
- [9] J. Bradshaw, M. Sierhuis, A. Acquisti, P. Feltovich, R. Hoffman, R. Jeffers, D. Prescott, N. Suri, A. Uszok, and R. V. Hoof, "Adjustable Autonomy and Human-Agent Teamwork in Practice: An Interim Report on Space Applications," in *Agent Autonomy*, H. Hexmoor, C. Castelfranchi, and R. Falcone, Eds. Springer US, 2003, pp. 243–280.
- [10] M. Ball and V. Callaghan, *Managing Control, Convenience and Autonomy*. Special Issue on Agent-Based Approaches to Ambient Intelligence, AISE book series, IOS Press, 2012.
- [11] M. Ball, V. Callaghan, and M. Gardner, "An Adjustable-Autonomy Agent for Intelligent Environments," in *2010 Sixth International Conference on Intelligent Environments (IE)*, 2010, pp. 1 – 6.
- [12] H. Hagras, V. Callaghan, M. Colley, G. Clarke, A. Pounds-Cornish, and H. Duman, "Creating an ambient-intelligence environment using embedded agents," *IEEE Intelligent Systems*, vol. 19, no. 6, pp. 12 – 20, Dec. 2004.[13] J. Chin, V. Callaghan, G. Clarke, "End-user Customisation of Intelligent Environments". In the handbook of Ambient Intelligence and Smart Environments, Editors: H. Nakashima, J. Augusto, H. Aghajan, Springer, 2010, Spring, pp 371-407, ISBN 978-0-387-93807-3.
- [14] M. Ball and V. Callaghan, "Introducing Intelligent Environments, Agents and Autonomy to Users," in *2011 7th International Conference on Intelligent Environments (IE)*, 2011, pp. 382 –385.
- [15] X. Wei and J. Yan, "Learner Profile Design for Personalized E-Learning Systems," in *International Conference on Computational Intelligence and Software Engineering, 2009. CiSE 2009*, 2009, pp. 1–4.

Improving Communication and Presence in Online Telepresence Systems

Alfonso TORREJON, Prof. Vic CALLAGHAN and Prof. Hani HAGRAS

Intelligent Environments Group, Department of Computer Science and Electronic Engineering, University of Essex, UK

Abstract. This describes research into a mechanism that enables geographically dispersed participants in telepresence system to be placed in artificial views that better mimics a real life lecture or meeting room situation. In support of this we present a novel solution for collaborative activity that converts participant's into Mixed Reality's visual objects allowing them to interact more naturally from any location, enhancing their communication.

The system enables people to logon, choose a seat or location (which also assigns them a virtual presence in that location) thereby enabling them to talk and interact, with their virtual neighbors. The sound volume can be controlled so as to produce a kind of virtual bubble that surrounds the participants allowing the audio to be directional and selective. In addition, attendees to the real environment can interact with the remote attendees.

Keywords. Directional audio, telepresence, immersive presence, MR directional audio, panoramic audio, immersive reality.

Introduction

Augmented Reality (AR) is a technology that enables users to interact and combine 3D virtual objects with the physical world in real-time applications. Until now AR technology has mostly been used to overlay virtual objects on physical scenes to in a way that augments the information value of the scenes. Most AR system used in education are used to visualize objects and processes that are invisible to the naked eye, such as molecules, animals, body parts and similar items. By way of an example, Cofin et al [1] proposed a system that addressed two main goals: the use of Augmented Reality for virtual annotations and illustrations which allowed students to interact with objects fellow students and the lecturer over great distances.

Augmented Reality and other Virtual Reality work largely focuses on the visual domain, with the audio side being given little or even no consideration at all. It is not always clear why that is but one reason might be that it was regarded as less important. The communication between objects and viewers is normally either via controlling an animation or auxiliary information such as text boxes or other overlays.

Some VR environments have tried to integrate audio communication, perhaps the most well regarding being Open Wonderland®, where it is one of their main competitive advantages. In their system they use directional audio with privacy spheres. However, the system is avatar based rather than video and so the sense of realism

suffers as a consequence. Our work goes beyond this by, in addition to using real video, providing the user with more control over the audio environment.

In this paper we present a similar strategy to that used in AR, but instead of using graphical objects, we use video of people in order to provide a more realistic mixed reality experience for participants. This type of mixed reality is often referred to as ***Immersive Reality***.

The motivation for our thread of work can be traced back to Billinghurst and Kato's 1991 paper [2] which pointed out the merit of "beyond being there" which mostly related to earlier Computer Supported Collaborative Work.

All setups used for telepresence have used similar methods to provide remote presence, some with more or less success. The main intention always has been to achieve feeling that is indistinguishable between attending locally or remotely.

When people communicate in a face-to-face conversation in the real world, there is a dynamic and easy interchange of information between the listener and the speaker's interpersonal space and a sense of sharing valuable information related to their personal goals. Equally the value of the information shared between individuals is related to the distance between them. People who "feel" closer together will share more intimate information.

It has been demonstrated that search interests of people who already connected via a social network, are more similar than random individuals. Moreover it was found that the longer they were sharing messages the closer they were [5]. Our system supports these ends by providing virtual bonds between people that are geographically dispersed. In our system those bonds are derived from their common goals, shared knowledge and desire for success. In addition, technical affordances such as synchronous communication which gives the opportunity for more intimacy, leading to a better understanding of each other, providing the opportunity to balance the groups weaknesses in order to achieve their goals.

1. Social Interaction and Social Presence

What makes students engage in an online virtual learning? Beyond the chosen subject itself, there is a social view that emerges in support of online virtual learning that argues the individual joins a community group and which gives rise to the potential for building and maintaining that sense in virtual classrooms [6][7].

There are 3 interrelated elements to be considered: ***Social presence***, ***teaching presence*** and ***cognitive presence***.

The CoI framework (Community of Inquiry) is a process model of online learning [8]. It assumes that effective online learning, especially higher order learning, requires the development of community, and that such development is not a trivial challenge in the online environment.

1.1. Social Presence

Social presence is defined as the degree to which the student feel socially and emotionally connected to others in the group, projecting themselves as "real" people, independent of the communication medium used [15]. Socio-cognitive theorists describe learning as an interactive group process in which learners actively construct knowledge and then build upon that knowledge through the exchange of ideas with

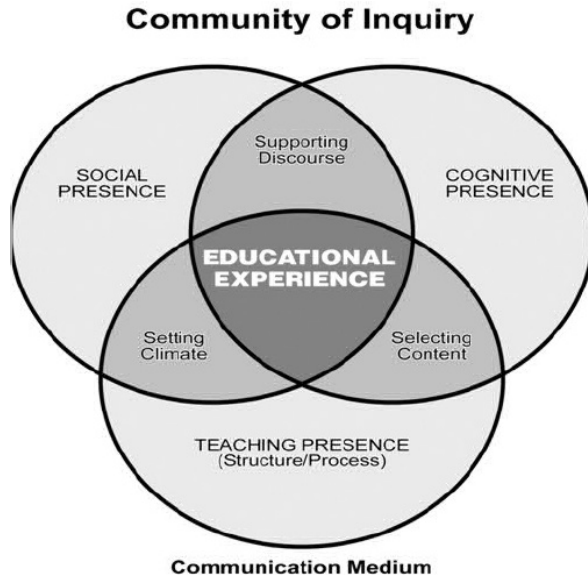

Figure 1. Community of Inquiry

others [9]. If the students are distant in traditional distance learning scenario will be condemned to isolation and loneliness of their own space without any possibility of synchronously exchanging ideas, and missing information beyond words and text that sometime are milestone in the learning process.

Studies on social presence with a large set of participants [11] determined that social presence was composed of three subjective elements: co-presence, intimacy, and immediacy, none of them naturally available at distance learning, so the need to build a model that takes those into consideration. In this ‘value social interaction’ and ‘learning interaction’ are the key factors needed to achieve learner satisfaction and goal achievement, which is basically the final goal of any teaching institution.

1.2. Cognitive Presence

Cognitive presence describes the extent to which the student is able to construct meaning through sustained communication, reflection and discourse.

Poor critical thinking has been found in some online discussions between students [10]. Results indicate that participants of some courses did not value the forum which was reflected in the quality of posts submitted. One of the reasons found is that, rather than critically analyzing each other’s posted comments, they tend to discuss the student-content interaction, failing to engage one another’s ideas (i.e. they are not recognizing the value of student-student interaction above the content) [12]. This can be illustrated using the Practical Inquiry Model (Fig.2) where there is a triggering event on a shared world, that began in the form of an issue or dilemma that needs resolution. As a result of this event, there is a natural shift to exploration in search for relevant information that can provide insight into the problem. As ideas grow, connections are made between all elements found and possible explanations, where finally, there is a selection and application of such solutions and resolution of the issue. This is the complex path of any critical analysis. The more participants and elements that are

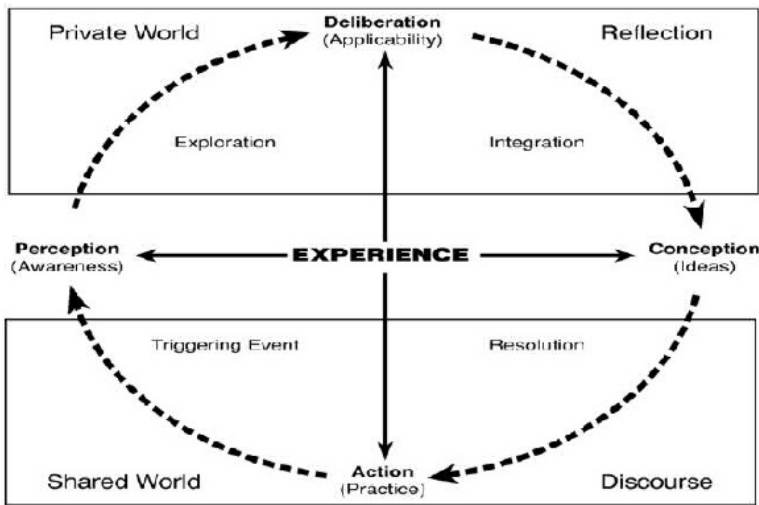

Figure 2. The Practical Inquiry Model (PI Model)

available to the deliberation, the higher the number of possible explanations that could be found, confirming the hypothesis that discussion enriches all path of exploration.

1.3. Teaching Presence

The glue to bring all together is teaching presence. By designing, facilitating and providing direction to the cognitive and social presence so as to allow students to achieve their full potentials. In traditional class teaching, the educator is responsible for providing emotional presence that will lure and engage the student into being inquisitive, in order to progress. The question arises as to the amount of support that teachers can provide to unknown remote students, with no physical links or contacts, rather barriers that limit their teacher-student contact. How can teachers replace the information provided in a face-to-face teaching sessions for students that are not present?

Emotions are present throughout our lives, and obviously are present in any online community [14][15]. Research on emotional presence, within online communities, demonstrates the existence of emotion in online learning. Given this reality, emotion must be considered, if not a central factor, at least as a ubiquitous, influential part of learning online [15].

Recent research in social presence [14][16] has suggested that an increase in social presence is important, not only for its impact on the quality of collaboration, but also for the development of shared group identity. Asynchronous methods lack the shared context, body information and timely feedback during collaboration, slowing down the whole process of creativity and leading to misinterpretation, reducing the perception of the common interest.

A recent development in collaborative working and learning has been the use of synchronous tools such as Web videoconferences, whereby learners meet online at a fixed time (synchronous) in an online classroom. While Web videoconferencing is not a new phenomenon, tools like Skype®, MSN Web Messenger® and Acrobat Connect® allow learners to communicate efficiently, they still create virtual barriers, as the distant

students are limited by the amount of communication that they may have with peers and teacher. Equally the lack of a sense of being socially embedded or immersed into the real space.

Until recently, basic technology would allow only for asynchronous communication, as in discussion groups, message boards and forums. Some courses have made use of those boards but with very poor response and results. For example, some learners reported a lack of spontaneity and improvisation that resulted from asynchronous communication, where frustration built up on the learners side while they were forced to wait for answers to their questions before being able to move on to the next point in the discussion [7].

Web and video conferencing have opened new dimensions for collaborative work. While the majority of students' time is spent in asynchronous activities (e.g. reading at library, preparing coursework and essays, searching for more information), the synchronous part of students' life is crucially important, such as attending debates, face-to-face tuitions and lectures, joining sporting groups and socializing at the University events. Web and Video based courses are often disappointing experiences for all ages groups but particularly for younger generations for the lack of those synchronously activities.

2. Approaches and Scenarios for Local and Distant

We now analyze a simple scenario based on traditional education. Student A, student B and student C arrive to their seminar room and seat contiguously.

As their lecture begins there are some questions that student B wants to confirm from student A, related to the taught subject. Naturally he/she will come closer to his/her ear and whisper the question. If the question stays unresolved then he/she might approach other people within close area (such as student C) or even will request attention from the tutor expecting a more public reply.



Figure 3. Traditional classroom seating

Now let's translate this scenario into the proposed distant learning scene. Let's consider student A and C arrive to their local seminar room, while the student B is attending remotely the lecture. Student A and C take a seat and student B remotely choose to sit on an empty chair between A and C.

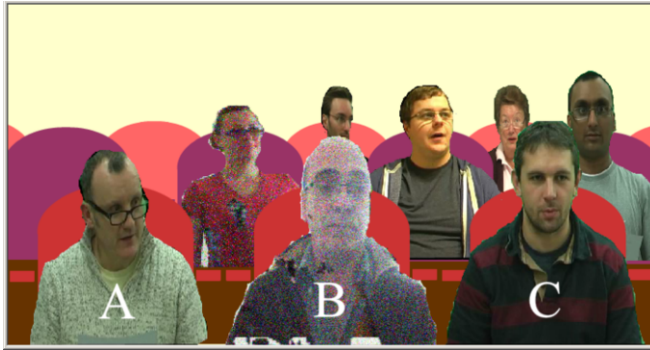

Figure 4. Distant students immersed in the real classroom

The first question to arise might be; how will student A, B, lecturer and other attendees (including distant learners), be aware that student B is “present”? While this question can be easily solved by using similar approach to AR using a real video stream (that is visible to all), a new question arises: How can they communication between them providing with the discussion being limited to the same spatial limits as in real life and, where the operation is controlled by the remote student?

Clearly, to be realistic, any comment from student B should only be heard by the person seating next to his/her virtual space. Similarly, if student B’s question stays unanswered then the need arises to approach other people near-by and, as last resort, the tutor or lecturer.

How the remote student will communicate their intention to speak? Evidently there is a need to model a system that takes all those issues into consideration.

3. Taking Spatial Ownership

The first problem is to define a system where the remote student can take ownership of a seating space to position him/herself among the other students, either other remote students or local attendees.

A spatial area is needed to be defined and coordinates passed onto the system. In our proposed scenario, a camera is kept pointing at the seating area, providing a similar view to that of the teacher. Students can click on the real time video image of the classroom at the available hotspots (real seating area) and, by doing so, will take ownership for that specific point in space. This spatial point will be released as soon as the student virtually leaves the room.

Once a student has taken spatial ownership then they virtually enter the physical room. Accessing the room is though a camera on the remote location (the distant student’s location and web camera) that will remove any background information and in real time will stream only the student’s body (removing background) onto the real-time video at the specific point chosen.

To do this convincingly it is necessary to consider the depth of view and ensure that closer students will occlude farther students (either remote or local ones).

By taking this spatial ownership we set the matrix where the distant student will remotely execute distant audio, defining who is within the different ranges and boundaries.

From this point onwards, groups are created dynamically to everyone's desire. Virtual and real spaces are synchronously mixed to the convenience of each element in the shared space. This space comes alive, not only for the distant student but also by the local ones, who can make use of this tool for their own internal communication without affecting the surrounding environment.

4. Aural Communication Channel

Real-time communication is a must, in order to support the emotions needed for a distant student to "feel" being part of the group, and for the local student to accept and identify the remote student as part of the group.

In Fig. 5 we illustrate our scheme for differentiating real students (blue dots) from immersive telepresence students (red dots). As any conversation between them should not reach public level, local students are encouraged to make use of their headphones connected to their network devices, such as their phones, tablets or laptops, which display a real time video showing the classroom view. Not only are they able to see their peers seated among them, but they will be able to hear and talk to them too, depending of their seating distance, as the boundaries will be set automatically depending the volume of the remote student (these audio levels are represented as ellipses in Fig. 5).

Natural speech is directional, therefore is necessary to take into account the location in space of the participants. This is easily managed with the built-in magnetic sensors that almost current pads and phones have. Equally this built-in facility is used to eliminate unwanted conversations of students away from the boundaries. When other students, either real or immersive, are talking between them, the audio will be automatically mute, if they are outside boundary thereby avoiding eavesdropping into each other's communication.

Rozier, Karahalios, and Donath [18], presented an augmented reality system using audio as the primary interface. Their intention was to create "audio imprints" at an

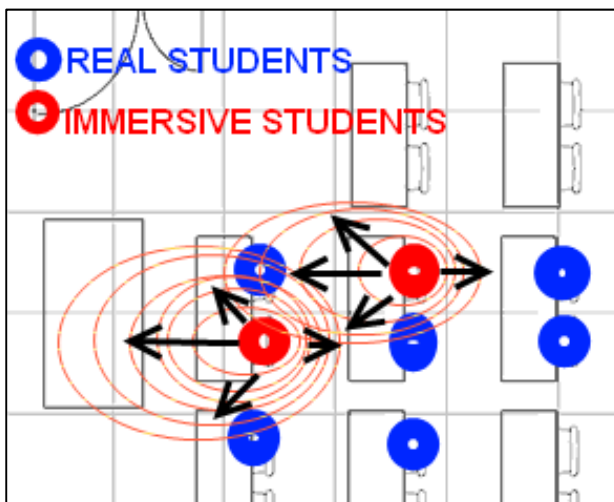

Figure 5. Communication between real and immersed elements

outdoor location where, at a later stage, other individuals could collect them as they travel through the author path. Our proposed model is somewhat similar, with the variant that an audio imprint is not recorded but, rather, lives audio, which is both directional and selectable by the author at any given point (i.e. the same that natural speech).

Our working system has been developed with ActionScript 3® (AS3) and Adobe Flash® for reasons of portability. There are some limitations but AS3 is a continually evolving language with new packages and classes becoming available every day.

Our audio system originally was developed for an immersive panoramic environment (360° real time video), positioning audio hotspots on a panoramic video which was presented in another paper at this conference [19]. It has been proven to be effective for most common types of room layout. For this reason the student's location is registered in relation to other elements as "audio hotspots". Local students wanting to use the immersive system will need to register their location by interacting with the video image.

While the experience has been taken from a panoramic scenario, a new algorithm has been developed to add elliptical behavior, due to the different goal (Fig.6) of trying to achieve a fixed directional audio. Binaural audio elements can be added to enhance the "feeling of been there".

Those locations are recorded in a database and presented to all users through a web query, making every device aware of the other's location. In normal operation, devices are querying frequently in order to draw their boundaries and find elements within their range (as they will be the only devices receiving the audio stream). Audio stream are dependent of the distance and position from the source, and the manual control of the audio originator.

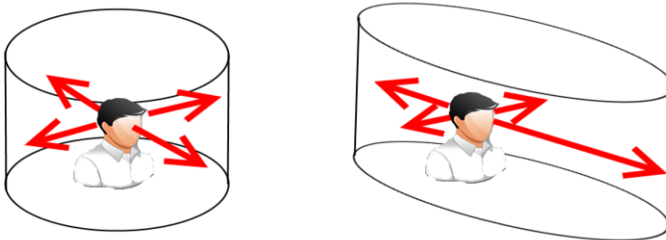

Figure 6. Circular and elliptical audio coverage

5. Visual Communication Channel

The immersive reality embedded into the real space (i.e. available to real people in the real teaching space) can only be provided by the use of networked devices, such as tables, smart phones and laptops (Fig. 7). Immersed students can be seen displayed either on students' tablet or another auxiliary projection system in the classroom (LCD screen or projector). Mixed elements can be tagged to provide extra information, such as the students' names, email contacts, public profiles and groups that belong to, etc... (as approved by the student whose information it is).

By the use of this method, teachers can experiment first-hand using face-to-face communication with remote students (and/or counterpart in collaborative teaching),

providing the necessary student-teacher relationship without the content interference. West [20] mentioned that one of the biggest challenges for teachers or instructors is the need to adapt to the lack of visual cues that by nature we use when interacting with people face-to-face. Until now preparing content that accommodates that lack of student-teacher interaction has been the main approach adopted but this is clearly not ideal.

Using this model teachers have the opportunity to enhance teaching by the adding aspects of augmented reality as the students already have tablets to facilitate this, without the need of any additional equipment (e.g. augmented glasses, 3D goggles with head-trackers, etc...) The usefulness of AR applied to learning has been demonstrated in many studies where participants were, for example, participants said they can memorize content better [21][23].

Constructivist theory underlines that knowledge is not transmitted from one “knower” to another but is actively built up by the learner, based on the way learners construct their own knowledge by testing ideas, taking different approaches, experimenting with the situation and comparing and contrasting what they already know. The closer that learners are to the reality, the faster they will build their knowledge [23].



Figure 7. Mixed real and Immersive Reality

6. Conclusions

In this paper, we have described a novel use of Immersive Reality based on embedding live video feeds into computer supported environments in a way that facilitates more realistic communication between them and their environment. We introduced the term, Immersive Reality and described our unique variant of it that used embedded real-time video and where the two elements interacting are video overlays on real space. In this world (i.e. the meeting or lecture setting) can be either left unmodeled or partially modeled to accommodate new structures and elements (such as AR and VR).

We provided a new insight to communication between participants in a telepresence session with the capability of applying segregation, occlusion and directionality, controlling the spatial domain for 1-to-1 and 1-to-many communication within the same event. Thus, from this model, individuals have the capability or dynamically extending or shrinking the communication group to accommodate their needs and even creating subgroups, modeling their relationship as they please.

7. Future Work

The proposed model has been tested technically at an experimental classroom level by making use of our iClassroom at the University of Essex. Transfer of this knowledge to a real classroom is needed in order to collect feedback from real students and teachers to get more definitive data.

References

- [1] C. Cofin, S. Bostandjiev, J. Ford and T. Hollerer. "Enhancing Classroom and Distance Learning Through Augmented Reality". *Proceedings of World Conference on Educational Multimedia, Hypermedia and Telecommunications 2010* (pp. 1140-1147).
- [2] M. Billingham, H. Kato. "Collaborative Mixed Reality". *Proceedings of the International Symposium on Mixed Reality (MR '99)*, March 19-21, 1999, Yokohama, Japan.
- [3] R.L. Draft, R.H. Lengel. "Organizational Information requirements, media richness, and structural design". *Management Science*, Vol. 32, 1991, pp. 554-571.
- [4] J. Short, E. Williams, B. Christie. "The Social Psychology of Telecommunications". London, Wiley 1976.
- [5] P. Singla, M. Richardson. "Yes, There is a Correlation - From Social Networks to Personal Behavior on the Web". *Proceeding of the 17th International World Wide Web Conference*, Beijing, China, 2008.
- [6] A. Rovai. "Building Sense of Community at a Distance". *International Review of Research in Open and Distance Learning*, Vol. 3 No. 1, April, 2002.
- [7] E.J. Stodel, T.L. Thompson, C.J. MacDonald. "Learners' Perspectives on What is Missing from Online Learning: Interpretations through the Community of Inquiry Framework". *Review of Research in Open and Distance Learning*, Vol. 7 No. 3, December, 2006.
- [8] D.R. Garrison, T. Anderson, W. Archer. "Critical inquiry in a text-based environment: computer conferencing in higher education". *The Internet and Higher Education*, 2, 2-3, 87-105, 2000.
- [9] A. Caspi, I. Blau. "Social presence in online discussion groups: testing three conceptions and their relations to perceived learning". *SocPsycholEduc*, April 2008.
- [10] L.M. Harasim, L.M. "Online education: Perspectives on a new environment". New York: Praeger 1990.
- [11] C. Wei, N. Chen, Kingshuk. "A Model for Social Presence in an Online Classroom". *Proceedings of the 18th International Conference on Computers in Education*. Putrajaya, Malaysia: Asia-Pacific Society for Computers in Education, 2010.
- [12] C. Angeli, N. Valanides, C. Bonk. "Communication in a web-based conferencing system: the quality of computer-mediated interactions". *British Journal of Educational Technology*, 34(1), 31-43, 2003.
- [13] P. Gustafson, D. Gibbs. "Guiding or hiding? The role of the facilitator in online teaching and learning". *Teaching Education*. 11(2), 195-210, 2000.
- [14] M. Cleveland-Innes, P. Campbell. "Emotional Presence, Learning, and the Online Learning Environment". *Research Articles in The International Review of Research in Open and Distance Learning*, Vol. 13, No. 4, October 2012.
- [15] G. C. Marchand, A. P. Gutierrez. "The role of emotion in the learning process: Comparisons between online and face-to-face learning settings". *The Internet and Higher Education*, 15(3), 150-160, October 2011.
- [16] R. Pekrun, T. Goetz, W. Titz, R. Perry. "Academic emotions in students' self-regulated learning and achievement: a program of qualitative and quantitative research". *Educational Psychologist* 37, 2, pp-91-106, 2002.
- [17] P. Rogers, M. Lea. "Social presence in distributed group environments: the role of social identity". *Behaviour & Information Technology*, Vol. 24, No. 2, March - April 2005, 151 - 158.

- [18] J. Rozier, K. Karahalios, J. Donath. "Hear&There: An Augmented Reality System of Linked Audio". International Conference for Auditory Display 2000, Atlanta, USA, April 2000.
- [19] A. Torrejón, V. Callaghan, H. Hagra. "Selectable Directional Audio for Multiple Telepresence in Immersive Intelligent Environments". IE'13, Athens, Greece. July 2013.
- [20] G. West. "Teaching and learning adaptations in the use of interactive compressed video". *T H E Journal*, 21 (9), 71-74, 1994.
- [21] D.D. Sumadio, D.R.A. Rambli. "Preliminary Evaluation on User Acceptance of the Augmented Reality use for Education". 2010 Second International Conference on Computer Engineering and Applications. Bali, March 2010.
- [22] W.F. Maqbleh, M.S. Sindhu. "From Boards to Augmented Reality Learning". Conference on Information Retrieval & Knowledge Management, (CAMP), 2010 International, March 2010.
- [23] H. Kaufmann, M. Csisinko, A. Totter. "Long Distance Distribution of Educational Augmented Reality Applications". Proceedings of EURO-GRAPHICS 2006, pp. 23-33. Blackwell, Oxford. 2006.

1st International Workshop on Museums as Intelligent Environments (MASIE'13)

Nikolaos Avouris (University of Patras, Greece)

Alexandra Bounia (University of Aegean, Greece)

Nikoleta Yiannoutsou (University of Patras, Greece)

Maria Roussou (University of Athens, Greece)

This page intentionally left blank

Museums as Intelligent Environments

Nikolaos AVOURIS^{a,1} Nikoleta YIANNOUTSOU^a Alexandra BOUNIA^b, Maria ROUSSOU^c

^aHuman Computer Interaction Group, University of Patras

^bDepartment of Cultural Technology and Communication, University of Aegean

^cMuseum Studies Program, University of Athens and Makebelieve Design & Consulting

Introduction

Modern museums seem to be today more open to technologies that may transform them to intelligent environments. The result of fusion of such technologies in museums may result in new kinds of augmented museum exhibits that sense visitors and interact with them and new kinds of visitors' experiences as they engage in new types of activities that transcend the linked physical and digital spaces. These new capabilities can enhance the educational and creative value of the museum visit.

Based on this layer of technology and related new possibilities for interaction and participation, personalized experiences to the visitors may be supported. The rationale for applying such techniques is that museums have a huge amount of information to present, which must be filtered and personalized in order to enable the individual user to easily access it. This is even more applicable if we consider the current trend of including in the content, user generated material, produced by crowd sourcing museum applications, social media etc., or use data from social behavior tracking.

The workshop is intended to act as a forum for reflection on the cultural experience supported by intelligent technologies and for exploration of new ideas. The papers submitted in this workshop analyze the role of intelligent technologies in supporting and focusing on different aspects of cultural experience like the following a) the social and affective dimension of museum visits [1], b) museums as spaces of interaction and navigation [2], c) personalized and adaptive narratives as vehicles for interaction with the exhibits and multimedia [3] d) natural language processing in approaching cultural experience through questions and answers [4] and e) learning in virtual museums [5] and learning through game play and game design [6]. The authors exemplify their approach with reference to specific museums for which technologies are designed. In the majority of the papers findings from evaluation studies are reported.

More specifically, the invited paper by D. Petrelli [1] stresses the problems arising from the emphasis on information delivery and discusses the role of smart technologies in supporting affective experience grounded in the materiality and authenticity of the exhibits.

Navigation and motion in space is analyzed in an empirical study [2] where technologies support smart routing. In this study recommendations are based on the visiting styles and the museum is modeled as a space where visitors meet and interact.

¹ Corresponding Author.

Storytelling supported by intelligent technologies is discussed as new means to structure cultural experience [3]. Specifically, the stories are tailored to visitor interests and adapt in real time to the changing parameters of the visit. The authors analyze how their approach is implemented in the Acropolis Museum and they discuss findings from an evaluation study with visitors.

Questions and Answers is one of the tools the visitors can use to become acquainted with cultural experience [4]. The authors of the paper propose a system called Virtual People factory which allows rapid prototyping of a “Questions and Answers” system. This system is enhanced by Natural Language Processing Elements in order to identify free form questions. A short study on the evaluation of the system is also presented.

Cultural experience and specifically the sense of presence in virtual museums is analyzed in relation to the diverse technologies employed [3]. The paper focuses on the learning dimension of the cultural experience and performs a statistical analysis of this experience in five Virtual museums using as basis for this analysis the construct of Generic Learning Outcomes.

The second paper on the learning dimension of the cultural experience discusses visitor engagement through game play and game design. The authors distinguish between the needs of teachers and students. This distinction underlies the design of MagMAR which is a system that combines a web interface targeting educators and a Mobile Augmented Reality game targeting students. The paper reports findings from an evaluation study in a museum of contemporary Art with a teacher and his students.

References

- [1] D.Petrelli, Digital –material Hybrid objects and augmented spaces to support the social experience of heritage. *Invited paper in International Workshop in Museums as Intelligent Environments. Workshop Proceedings of the 9th International Conference on Intelligent Environments, Amsterdam: IOS Press (in press)*
- [2] I.Lykourentzou, X. Claude, Y. Naudet, E. Tobias, A. Antoniou, G. Lepouras and C. Vassilakis. Improving museum visitors’ Quality of Experience through intelligent recommendations: A visiting style-based approach. *International Workshop in Museums as Intelligent Environments. Workshop Proceedings of the 9th International Conference on Intelligent Environments, Amsterdam: IOS Press (in press)*
- [3] L. Pujol, A. Katifori, M. Vayanou, M. Roussou, M. Karvounis, M. Kyriakidi, S Eleftheratou and Y. Ioannidis. From personalization to adaptivity. Creating immersive visits through interactive digital storytelling at the Acropolis Museum. *In International Workshop in Museums as Intelligent Environments. Workshop Proceedings of the 9th International Conference on Intelligent Environments, Amsterdam: IOS Press (in press)*
- [4] I. Doumanis, S. Smith. Beyond Artificial Intelligence Markup Language (AIML) Rapid prototyping of a Q&A system. *In International Workshop in Museums as Intelligent Environments. Workshop Proceedings of the 9th International Conference on Intelligent Environments, Amsterdam: IOS Press (In press)*
- [5] S. Sylaiou, K. Mania, F. Liarokapis, V. Killintzis, I.Paliokas and P. Patias. Exploring the effect of diverse technologies incorporated in virtual museums on visitors’ perceived sense of presence. *In International Workshop in Museums as Intelligent Environments. Workshop Proceedings of the 9th International Conference on Intelligent Environments, Amsterdam: IOS Press (In press)*
- [6] I. Di Loreto, M. Divitini, I. Trimailovas and M. Mander. Playing in museums by constructing your game. *In International Workshop in Museums as Intelligent Environments. Workshop Proceedings of the 9th International Conference on Intelligent Environments, Amsterdam: IOS Press (In press)*

Exploring the effect of diverse technologies incorporated in virtual museums on visitors' perceived sense of presence

Stella SYLAIYOU^{a,1}, Katerina MANIA^b, Ioannis PALIOKAS^c, Vassilis KILLINTZIS^d,
Fotis LIAROKAPIS^e and Petros PATIAS^f

^a *School of Social Sciences, Hellenic Open University, Greece*

^b *Faculty of Computer Science, Polytechnic School, University of Crete, Greece*

^c *Democritus University of Thrace, Greece, Greece*

^d *Lab of medical informatics Aristotle Univ. Thessaloniki*

^e *Coventry University, UK*

^f *Faculty of Rural & Surveying Engineering, Aristotle University of Thessaloniki*

Abstract: This paper presents the preliminary results of a research project aimed at exploring the perceived sense of presence incorporated in diverse technologies used in Virtual Museums. It initially presents the selection criteria and the five museum websites involved in the analysis. Then, it describes the evaluation process, in which a group of subjects explored the museums' on-line resources and completed a presence. The results of a double-phased statistical analysis are discussed, which investigated the technological conditions under which a Virtual Museum enhances the visitors' experience of presence.

Keywords: Virtual museum, presence, evaluation

Introduction

Cultural organizations, such as museums are in continuous development and performance improvement, effectively monitoring trends and assessing their progress. Cultural organizations such as galleries and museums, experience a fast-moving change derived from the proliferation of ICT tools and technologies, including the WWW. Interactive 3D computer graphics content is often adopted by museums in order to entertain and educate the wide public in an innovative and interactive manner. Virtual museum exhibitions allow museums to easily exhibit vast collections of digitized objects and overcome limitations of the physical objects' fragility, lack of exhibition space and cost. The virtual museums provide also the opportunity to people that live far away from the "brick and mortar" museums and to people with disabilities to visit their exhibitions and obtain an engaging and educative museum experience. Virtual museum visitors are becoming accustomed to technology being increasingly technologically aware also expecting exhibits and information to be technologically aware [1]. They demand a high level of experience quality through interactive digitized content. Virtual

¹ Corresponding Author.

museums should be engaging and legible, so as to be correctly interpreted, stimulate thought, and trigger enjoyment, inspiration and creativity satisfying human curiosity. One of the main quality criteria that contribute significantly to the quality of experience while engaged in a virtual museum exhibition is associated to users' level of 'presence' or 'sense of being there', in the virtual museum. Presence has been considered a generic metric assessing the overall experience of the visitor rather than the information retained or the visitor's success in task completion. Previous research explored the effect of technologies such as interactive 3D graphics and augmented reality incorporated in a virtual museum website on visitors' perceived presence [2, 3, 4].

As more museums, libraries, archives and galleries move towards digitizing displays and exhibitions incorporated in their official websites, a series of questions have emerged from scholars as to how visitors and the wider society perceive 'online museums' and their 'digital heritage' [5, 6] in relation to the physical museum's experience. Museum visitors may interact with the virtual museum environment via a constructive dialogue that provides them with access to thematic information and explanations about the museum objects' context selecting the level of information and the amount of detail they prefer. They shift their focus from the high-quality presentation of collections to the making of meaning related to the artefacts and their interpretation. There is the constant need for virtual museums to reach out and attract larger and more diverse audiences and find ways to understand visitor expectations and experiences, in order to address the needs of diverse user groups and be responsive to various communities' interests. On-line museum resources signifying 'digital heritage' provokes an innovative area of studying the visitor's interaction with on-line catalogues, digital objects and virtual exhibitions in relation to the technologies embedded in digital cultural spaces [7, 8]. The study presented in this paper describes compares and evaluates visitors' sense of presence after being exposed to five virtual museum websites that incorporate diverse technologies, such as panoramic images, scalable images, searchable database, web3D environments, Flash technologies and videos. The scope of this paper is to explore the effect of diverse technological characteristics of on-line digital museums on users' level of perceived presence or sense of being there, in the virtual museum environment.

1. Background

1.1 Presence in Virtual Environments

The main aim of a Virtual Environment (VE) is the ability to mislead one's senses so well that the illusion of being in the real-world situation simulated is created. Thus, the sense of presence is the design aim of a simulation. Presence is defined as the sense of "being there" in a mediated environment, e.g. the degree to which the users feel that they are somewhere other than they physically are while experiencing a computer generated simulation [9, 10]. Perceived presence could also be explained as the extent to which a VE becomes the dominant one—i.e., that the participants will tend to respond to events in the VE rather than in the real world [11]. In a study [12] the sense

of presence signifies behaving in the VE as in the real-world. Presence in the virtual environment, as sensed by the users of a simulator, cannot be directly linked to a specific type of technology; it is a product of the mind [13]. According to Heeter [14] there are three different kinds of Presence; Personal, Social and Environmental Presence. *Personal Presence* is the degree that someone feels part of the VE. *Social Presence* is the degree that someone feels that other beings exist in the VE aware of the user's existence. *Environmental Presence* refers to the degree the environment is aware of user's existence and responds to user's interaction. According to his empirical definitions [15] Schloerb distinguishes two types of presence; *Subjective presence* is the degree that a VE user feels physically present in the VE; and *Objective presence* is the likelihood of successfully completing a task, which is considered as the most significant criterion. The idea of *Cultural Presence* was introduced by Champion [16] and corresponds to the feeling that people from a specific culture while occupying a VE transform a digital space into a culturally meaningful place. Presence will be enhanced if the content is realistic and relevant in terms of social or cultural factors [17]. Pujol and Champion [17] also suggest that a definition of presence as simply 'being there' is unacceptable, because "these words have different meanings in different societies, and because culture is understood by ongoing usage rather than by instantaneous depiction." The first studies on presence assessment mainly focused on measuring the effects of VE technologies [18] using questionnaires [19, 20]. According to [21] researchers must collect complementary information in order to explore and investigate the factors inducing a high level of presence in cultural VEs. Here, we examine perceived presence after exposure to specific virtual museums and related artifacts and their context. The goal of the study presented in this paper is to explore whether users' level of 'presence' or 'sense of being there' is affected by the diverse technologies incorporated in the web sites of five on-line museums.

1.2 Virtual Museums Incorporating Diverse Technologies

In order to group the existing museum websites into representative categories, a team of four scientists with extensive experience in art education, educational design and ICT in education was assembled. Museum online resources were firstly divided according to their general representation method, which corresponds to panoramic images (QTVR), scalable images with text, searchable databases, 3D environments, and videos. The experts shared a preselected pool of museum websites and worked independently to extract within these categories, the factors that influence the user's experience according to their personal experience and recent literature results. In the next step, the factors were merged into a set of five qualities or capacities: imageability, interactivity, navigability, personalization and communication (Table 1). Each of them is defined by a number of features and that can be found in different degrees in the aforementioned visualization categories. Potential on-line museums to be incorporated in the study were compared against these specifications and the on-line museum which fulfilled better each category's expectations was selected. Of the five representative cases of virtual museums, four serve as on-line extensions to existing physical museums, while one only exists on-line without a physical counterpart.

Table 1: List of the questions included in the questionnaire and their correspondence with the GLOs

Virtual museum quality	Virtual museum definition
<i>Imageability</i>	Perceptual quality of a Virtual Environment that makes it memorable
<i>Interactivity</i>	The HCI functionality that makes a Virtual Environment able to communicate with its visitors
<i>Navigability</i>	The degree to which navigation capabilities are perceived from structural elements of the Virtual Environment
<i>Personalization</i>	The degree to which a virtual visit can be adjusted to personal preferences and needs
<i>Communication</i>	Communicational capabilities and communicative profile of the institution

In order to explore visitors' sense of presence while interacting with on-line virtual museums, five on-line international museums have been selected. They have been classified according to the following categories.

Imageability in panoramic images

The participants experience interactively the virtual museum space via panoramic images and get a feeling of the real museum's space thanks to the possibility to rotate and pan, zoom in and out, and navigate panoramic images of the galleries. This technique is convenient for medium to big size museums in which the architectural settlement is highly memorable or it is important to convey the design of the exhibition (selection, placement, lighting of objects, and continuity and cohesion of the exhibition discourse). The selected case for this study represented as M1 is Washington's National Gallery of Arts "Virtual Exhibition Tours" (<http://www.nga.gov/onlinetours/index.shtml>), in which visitors can select specific works of art for larger image views, close-up details, streaming audio commentary, and information about the object (Figure 1).

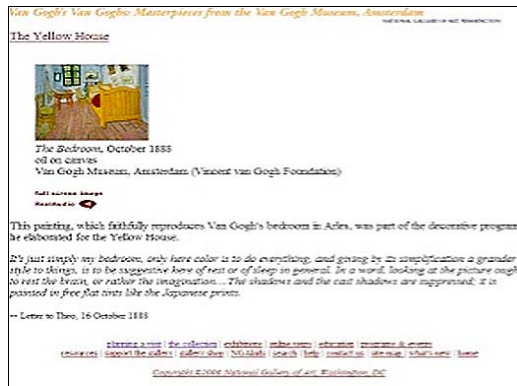

Figure 1: Washington's National Gallery of Arts "Virtual Exhibition Tours" website

Interacting with texts and scalable images

Image scalability and details on demand function provide the opportunity to examine museums' artifacts or parts of them in detail by applying zoom tools over high resolution images. These zoom-on-demand features take the dialectic between visitors and artifacts at a higher level since they allow seeing things that are not visible to the naked eye because of their size or because of the museums' spatial proximity restrictions. The VEs are highly interactive and enhance museum experience. The selected case for this study represented as M2 is the Metropolitan Museum of New

York (<http://www.metmuseum.org/>). In this website the visitors are able to navigate the museum's collections, locate exhibits of their interest, and take information via zoomable images and detailed textual exhibit information (Figure 2).

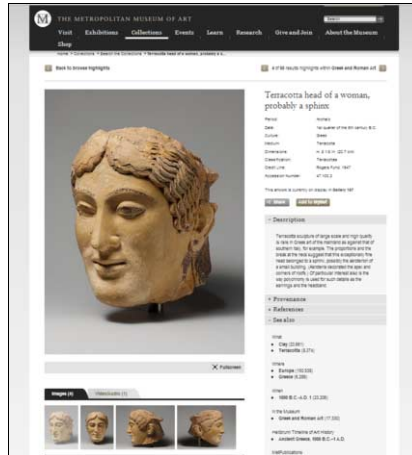

Figure 2: Metropolitan Museum of New York website

Searching utility for images and texts

This type of online museum environments offers multiple search options and enhanced image manipulation. This searchable database contains 2D representations, photos of objects along with their metadata, which are uploaded to the museum's online database in order to make a selection of the museum's collection. The website has a search engine which allows searching by content, concept, or metadata, thanks to an entry point usually consisting of a text area, in which visitors enter search criteria based on keywords. The selected case for this study represented as M3 is the Museum of Modern Art (<http://www.moma.org/explore/collection/index>). Through its database, visitors can navigate the various thematic areas of the museum and search its collections by artist, work or keyword. It also has an advanced search that allows adding refinement criteria such as period or object's management status (Figure 3).

Simulation and navigability in a virtual museum space

This type of online resource allows free and interactive real-time navigation in a 3D space reproducing more or less realistic reconstructions of museum galleries and containing mainly 3D representations of museum exhibits along with different kinds of associated information. This kind of online resources usually seeks to reproduce as realistically as possible [22] the experience of the visit, with the added value of the multimedia information, the hypertext/spatial navigation, and the possibility to manipulate (zooming, rotation) objects. The selected case for this study represented as M4 is the Van Gogh Virtual Museum (<http://www.vangoghmuseum.nl/>), which constitutes a typical example of a 3D reconstruction of a museum setting using computer-aided design tools and gaming technologies (Figure 3). The navigation is possible thanks to a user interface that is freely available for download or may be embedded in the web browser using common plug-ins.



Figure 3: Van Gogh Virtual Museum

Personalized exploration of a video archive

The last category corresponds to museum websites containing embedded videos. The selected case for this study represented as M5 is the Virtual Silver Screen of the Library and Archives Canada (<http://www.collectionscanada.ca/silverscreen/>). The website uses Flash technologies to present different Canadian films (now historic documents) of the early 20th century organized by themes (Figure 4).



Figure 4: Virtual Silver Screen of the Canada Library and Archives website

2. Materials and Methods

2.1 Apparatus and Visual Content

The experiments ran on an HP workstation including two 2.4 GHz Xeon processors and 2048 MB of memory. Standard display technology, such as a 19' monitor was used.

2.2 Participants

A total of 64 volunteers (31 males and 33 females, aged 19-37) mainly undergraduate and postgraduate students from the Aristotle University of Thessaloniki, Greece,

participated in the experiment. Participants in all conditions were naïve as to the purpose of the experiment. After they navigated the virtual museums environment and performed the assigned tasks, they were subsequently asked to fill in the presence questionnaire. All the participants reported to have at least a basic knowledge of computers and their knowledge of the English language was excellent.

2.3 Experimental procedure and metrics

The settings were as realistic as possible with respect to those in practice. Four steps were undertaken including: (a) goal setting (users start with a plan of the tasks to be accomplished), (b) exploration (users explore the interface and discover useful actions), (c) selection (users select the most appropriate actions for accomplishing their task) and (d) assessment (users interpret the system's responses and assess its progression). Initially, the participants were informed about the scope of the study and were informally interviewed in private. The evaluation involved one participant at a time and experimental assistants provided help when needed. The evaluation and the interviews took place in the laboratory of Photogrammetry and Remote Sensing of the Aristotle University of Thessaloniki, Greece. The evaluation used cued testing, which involves explaining to the users what the program is about and asking them to perform specific tasks or to answer questions. The users were provided with written instructions concerning sets of predetermined tasks which guided them to navigate the virtual museum exhibitions' websites. The next stage was concerned with the user's ability to move through the contents of an interactive program in an intentional manner. They performed tasks such as exploring the virtual museum, selecting museum exhibits and getting informed by reading and listening to information about their context as well as zooming in the images. In order to measure perceived presence of visitor's interacting with the virtual museums presented in section 2.2, a Virtual Reality Presence Questionnaire (Slater 1999) was presented to them after they interacted with each virtual museum. The questionnaire included a series of questions inquiring about their experience rated on a numeric Likert scale from one to seven with seven representing a high level of presence and requiring around 10 minutes to complete. The original VR Presence questionnaire (Slater 1999) was modified since it was originally constructed to assess presence in immersive environments to specifically refer to a virtual museum scene in a website environment.. Its first two questions concerned the extent to which the participants used computers in their daily activities and the extent they were familiar with VR, AR and computer games, respectively. The next eight questions assessed the sense of being there and more specifically the degree to which individuals experience presence while interacting with a virtual museum exhibition (*ibid.*). The virtual museum visitors described their experience in virtual museums as compared with their experience in traditional museums. The participants were asked to assess whether the virtual museum visited appeared as a group of images that they had seen, or as a gallery that they had visited. They were asked to evaluate the virtual museum system intuitiveness, the naturalness of control and of the interactivity as well as the degree to which they felt present in the virtual museum exhibitions. Finally, the participants were asked to assess their involvement in the procedure evaluating the degree they lost the sense of time. The last question evaluated the degree to which the participants consider they completed the procedure and the relevant tasks.

3. Results

Initially, the average of each question per group of questions and museum was calculated. In this respect, a “virtual presence” index (denoted PM) was calculated by averaging the results of the respective questions per questionnaire and museum. Then, the Kolmogorov-Smirnov was used as a goodness of fit test and tested for normality of the distribution results. It is assumed that the average score of the presence questionnaire questions provides a way to measure the sense of presence of the end-users, derived after interacting with each of the five virtual museums. It is also assumed that the derived presence scores vary according to the technologies incorporated in each virtual museum for enhancing the virtual museum experience, e.g. causation is assumed. The presence results relevant to each of the five virtual museums were compared with a direct visual inspection of the relevant histograms. Conclusions were extracted and based on the frequency of the low (smaller than 3) and of the high ratings (greater than 5). In these graphs that present the frequency bars, the rating scale is divided in six (6) bars. Then, the total sum in each bar was divided by the total number of the participants’ questionnaires and multiplied by one hundred for providing the % frequency of the counts for each bar. These graphs provide an image of participants’ scores distribution. The data that emerged adding the frequencies for each bar, were visualized with the aid of cumulative histograms for the optical/ visual inspection of the differences in the data distribution. The standard deviation was also visualized. Boxplots were used to represent the central area, as well as the information concerning the range of scores. The statistical tests ANOVA single factor and t-test were used to explore whether the differences between the virtual museums’ results are statistically significant or not.

The total counts in each bin (i.e. the total number of PM indices that lie in each bin range) are then divided by the total number of counts (i.e. the total number of questionnaires) and multiplied by 100 to produce the per cent frequency of counts per bin. These graphs provide an image of the distribution of the ratings among the participants. Furthermore, by adding the frequencies of each subsequent bin a “cumulative frequency histogram” is produced (Graph 1).

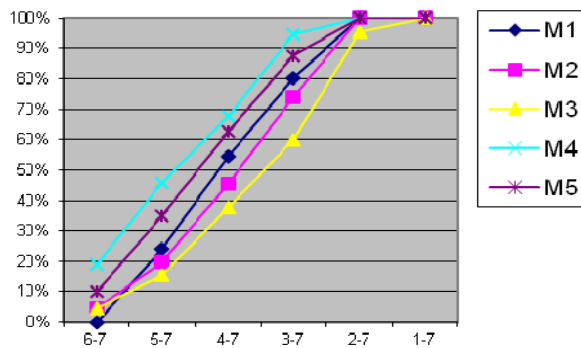

Graph 1: Cumulative frequency of museums M1, M2, M3, M4, M5

The cumulative frequency histogram (Graph 2) showed that the third museum had the lowest score in a scale range from 2 to 3 (35%). Also, the Van Gogh virtual

museum (M4) and the Cinema Virtual Museum (M5) had the highest scores in a range of 5 to 7 (41% and 36% respectively). The scores below the mean (3) were 90% for the Van Gogh virtual museum (M4) and from the Cinema Virtual Museum (M5), 80% (M1), 74% για το Metropolitan Museum of New York (M2) and 60% for the Museum of Modern Art MOMA (M3). According to the histogram of cumulative frequency and the boxplots the Van Gogh Virtual Museum (M4) has the greatest median (5) and the most high scores between 3,67 and 5,67, but at the same time it has a great range of scores. It follows the Cinema Virtual Museum (M5). Its greatest score is the same with that of the Van Ghogh Virtual Museum (M4), and more specifically 6,78 with a median 4,28. The half scores range between 3,64 and 5,44. Then it follows the virtual museum of the National Gallery of Art (M1) with median the 4,23 and the half of its scores in a range between 4,97 and 3,22. The Metropolitan Museum of New York (M2) comes immediately after with the highest score the 6,5 and the lowest the 2,11. Its median is 3,89 and its half scores range between 3,03 and 4,64. Finally, the Museum of Modern Art MOMA (M3), που has the lowest scores, with median 3, 44 and lowest score the 1,78. The half of its scores were from 2,67 to 4,33. The error bars shown in the Fig. 2 correspond to the standard deviation of each distribution. The comparative boxplots concern the sense of presence. The median scores of the five museums were noted with a dotted line.

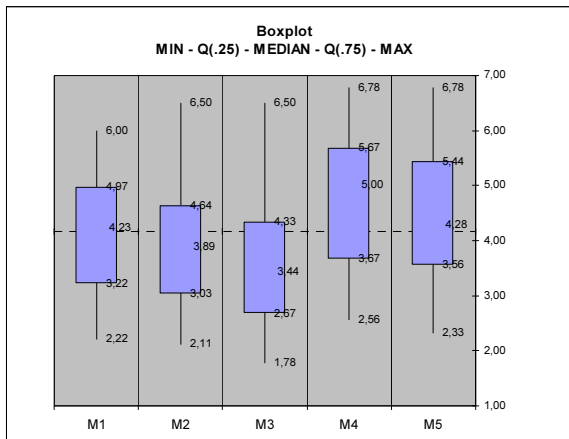

Graph 2: Summary statistics (mean and standard deviation) for the five histograms

The elaboration methodology adheres to following four steps: (i) It is assumed that the average of the ratings in the eight questions gives a measure of “virtual presence” (PM index) for the five museums. (ii) It is assumed that this is directly related to the method used by each museum to enhance the virtual tour (i.e. “causation” is assumed). (iii) The PM results for the five museums are compared by direct visual inspection of the respective histograms. (iv) Conclusions are drawn based on the frequency of bad scores (< 3) and high scores (> 5). According to the Graph 3 that depicts a bell-shaped probability density curve there are not any results concerning the sense of presence in the websites of virtual museums. An expected result/note is that the Museum of Modern Art (MOMA) (M3) with the searchable database has accepted the most negative grades.

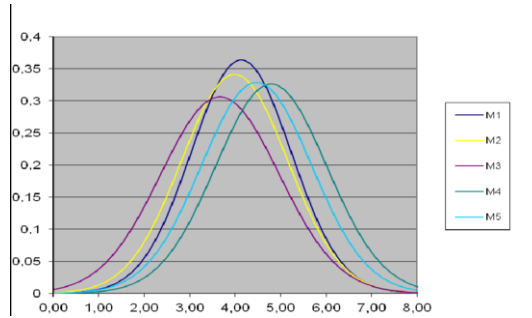

Graph 3: Normal distribution of museums 1, 2, 3, 4, 5

The above presented histograms revealed the following: (a) The frequency histogram of the third museum showed that it had the lowest score in the rank 2-3 (35 per cent), (b) The frequency histograms of the M4 and the M5 museum showed the highest scores in the range 5-7 (41 per cent and 36 per cent, respectively), (c) The cumulative histograms of all five museums revealed that the scores above average (3) were 90 per cent for M4 and M5 museum, 80 per cent for the M1, 74 per cent for the M2 and 60 per cent for the M3. Based on these findings (particularly the high scores M4 and M5 and the low score of M3) it may be argued that the methods employed to enhance the virtual presence in M4 and M5 are better than those used in museums M1 to M3. With the statistical test ANOVA single factor showed that there is marginally statistically significant difference between the museums in the sense of presence, because $p=0,0019$ ($p<0,01$). In order to explore whether there are statistically significant differences between the museums a t-test was conducted. The museums were tested by pairs. The results show that with strictest cut-off point for significance level (0.01), the pairs of museums that have statistically significant differences between them are the following:

- M1 significantly higher presence than M3,
- M1 significantly lower presence than M4,
- M2 significantly lower presence than M4,
- M3 significantly lower presence than M4,
- M3 significantly lower presence than M5,
- M4 significantly higher presence than M5.

4. Discussion and conclusions

The statistical results indicate that the virtual museum of Van Gogh virtual museum (M4), which uses Web3D technology and offers real-time navigation in three-dimensional space, has evoked a high level of perceived presence. While interacting with M4, the virtual visitor could view each cultural object from different angles based on its context, and, therefore, complete and documented mental models are evoked realizing the full potential of the virtual museum [23]. In M4, the virtual visitor can acquire the same or even additional information compared to the experience of visiting the physical museum. The virtual visitor is able to dynamically interact with the virtual museum, wonder freely in the 3D space, 'stand' in front of the exhibits and get information about them and their context. Potentially, perceived presence after being

exposed to the Van Gogh virtual museum could have been even stronger. The technical flaws of the virtual museum application and its requirements in terms of Internet speed affected the experience of the virtual visitors, as well as the feeling of presence in the 3D interactive environment. The experimental process showed that the 3D virtual tour of the museum suffered certain usability issues. For instance, in order to have access to the virtual museum, the user initially would have had to create an account. A number of participants reported that despite the fact that they had followed the instructions provided, they faced difficulties while navigating the virtual museum. After creating an account, the visitor was instructed to install the standalone virtual museum application. In some cases it was reported that the installation caused confusion, delays and problems for certain participants who had limited Internet experience. For the application to properly function, an easy-to-follow procedure and constant speed Internet connection was a prerequisite. The application required fast network access to the server of the museum in real time, in order to receive the data requested by the virtual visitor, for instance, specific information about a painting. In three cases, participants complained that here were either delays or failure of data mining the virtual museum exhibits because of a slow Internet connection.

A broader look at the results of this study shows that virtual visitors feel present in a virtual museum when they can dynamically interact with the environment while being exposed to multimodal (tactile, visual and aural) interaction while navigating through it. Based on the statistical analysis presented in the previous section, it can be concluded that interacting with text, scalable images and 3D models in a virtual museum website, such as the Metropolitan Museum of Art in New York (M2), results in high levels of perceived presence. Multimodal interactivity enhances the feeling of being there in a technologically facilitated environment, such as a virtual museum interface. Our results revealed that the experience of browsing through virtual museum space and the ability to select exhibits to view enhances visitors' sense of presence by making them feel part of the virtual museum. The direct interaction with dynamic objects contributes to the visitors' sense of immersion and allows them to be absorbed by the presentation of the virtual exhibition.

The text and Quick Time Virtual Reality (QTVR) technology virtual museum that imitates reality (M1) received high scores. As other researches pointed out QTVR technology can provide a sense of presence [24, 25] and give the sense of exploration of the museum scene.

As shown by the presence scores, certain technologies of personalized exploration of a video archive, as used by the Virtual Silver Screen of the Canada Library and Archives website (M5), contributed significantly to visitors' sense of presence. The user's interaction with the virtual museum environment enhanced their sense of presence providing a low-cost and user-friendly solution of wide acceptance which induces satisfactory level of perceived presence in a virtual museum.

The Museum of Modern Art MOMA (M3), which uses a searching utility for images and texts, induced the lowest level of presence in relation to the remaining virtual museums of this study. M3 did not intrigue the visitor's interest by providing limited information about the exhibits and did not encourage the virtual visitor to actively participate in the museum experience. Presence and enjoyment have been shown to be positively correlated and can play an essential role in the virtual museum experience [4]. The common approach of employing a thumbnail gallery leading to high resolution images was proved to be inadequate in terms of visitors' expectations as well as failed to provoke feelings of presence in a virtual museum environment.

More research is necessary to further identify the correlations between users' learning and the usability of virtual museums interfaces. Future research will investigate if and how they are influenced.

References

- [1] Falk J.H., Dierking LD (2000). *The museum experience*, Walnut Creek, CA: Alta Mira Press.
- [2] Di Blas, N., Gobbo E., Paolini P. (2005). *3D Worlds and Cultural Heritage: Realism vs. Virtual Presence*, in J. Trant and D. Bearman (eds.). *Museums and the Web 2005: Proceedings*, Toronto: Archives & Museum Informatics, published March 31, 2005 at <http://www.archimuse.com/mw2005/papers/diBlas/diBlas.html>
- [3] Pujol-Tost L., Champio E. (2007). *A Critical Examination of Presence Applied to Cultural Heritage*. In 10th Annual International Workshop in Presence, PRESENCE 2007.
- [4] Sylaiou S., Mania K., Karoulis A., White M. (2010). Presence-centred Usability Evaluation of a Virtual Museum: Exploring the Relationship between Presence, Previous User Experience and Enjoyment. *International Journal of Human-Computer Studies* (IJHCS), 68(5), pp. 243-253.
- [5] Parry R. (2005). Digital heritage and the rise of theory in museum computing. *Museum Management and Curatorship*, 20(4), pp. 333-48.
- [6] Parry R. (2007). *Recoding the museum: Digital heritage and the technologies of Change*. Abingdon: Routledge.
- [7] Marty, P. (2007). Museum websites and museum visitors: Before and after the museum visit. *Museum Management and Curatorship*, 22(4), pp. 337-60.
- [8] Marty, P. (2008). Museum websites and museum visitors: digital museum resources and their use. *Museum Management and Curatorship*, 23(1), pp. 81-99.
- [9] Stanney, K.M. et al., (1998). After-effects and sense of presence in virtual environments: formulation of a research and development agenda. Report sponsored by the Life Sciences Division at NASA Headquarters, *International Journal of Human-Computer Interaction*, 10 (2), pp. 135-187.
- [10] Ijsselsteijn, W., deRidder, H., Freeman, J., Avons, S.E. (2000). Presence: concept, determinants and measurement. In: *Proceedings of the SPIE, Human Vision and Electronic Imaging V* (3959-76). Presented at Photonics West—Human Vision and Electronic Imaging V, January 23-28, San Jose, USA. /<http://www.presence-research.orgS>.

- [11] Sadowski, W., Stanley, K. (2002). Presence in virtual environments edited by K.M. Stanney. In *Handbook of virtual environments: Design, implementation and applications*. Lawrence Erlbaum Associates Inc., Mahwah, NJ. pp.791-806.
- [12] Sanchez-Vives M.V., Slater M. (2005). From presence to consciousness through virtual reality. *Nature Reviews Neuroscience*, 6(4), pp. 332–339.
- [13] IJsselsteijn, W.A., Riva, G. (2003). Being There: The experience of presence in mediated environments. In: Riva, G., Davide, F., & IJsselsteijn, W.A., (eds.), *Being There - Concepts, Effects and Measurements of User Presence in Synthetic Environments*, Amsterdam: IOS Press. pp. 3-16.
- [14] Heeter C. (1992). Being There: The Subjective Experience of Presence, Telepresence, *Presence: Teleoperators and Virtual Environments*, 1(2), spring 1992, MIT Press, pp.262-271
- [15] Schuemie M., Straaten P., Krijn M., Mast C. (2001), Research on Presence in VR: a Survey, *Cyberpsychology and Behavior*, 4, pp. 183-201.
- [16] Champion, E., 2005. Cultural presence. In: S. Dasgupta, ed. *Encyclopedia of virtual communities and technologies*. Hershey, PA: Idea Group Reference, 95–101.
- [17] Pujol L. and Champion E., (2012). Evaluating presence in cultural heritage projects, *International Journal of Heritage Studies*, 18(1), pp. 83-102.
- [18] Barfield W., Zeltzer D., Sheridan T., Slater M. (1995). Presence and performance within virtual environments. In *Virtual Environments and advanced interface design* edited by W. Barfield and T.A. Furness. Oxford University Press, New York, 1995, 473-513.
- [19] Witmer, B.G. & Singer M.J. (1998). Measuring presence in virtual environments: A presence questionnaire. *Presence*, 7, pp. 225-40.
- [20] Slater M. (1999). Measuring presence: A response to the Witmer and Singer Presence Questionnaire. *Presence*, 8(5), pp. 560-565.
- [21] Slater M., Garau M. (2007). The Use Of Questionnaire Data In Presence Studies: Do Not Seriously Likert. *Presence: Teleoperators Virtual Environments*, 16(4), pp. 447-456
- [22] Paliokas I., Buda V., Iancu A.R. (2010). *Archaeo Viz: A 3D exploratory learning environment of reconstructed archaeological sites and cultural artefacts*, In *Proceedings of International Conference on Signal Processing and Multimedia Applications (SIGMAP, part of ICETE 2010 joint Conference)*, Athens, pp. 211-214.
- [23] Chittaro L., Ieronutti L., Ranon R. (2006). Adaptable visual presentation of 2D and 3D learning materials in web-based cyberworlds, *The Visual Computer Journal*, 22(12), pp. 1002-1014.

[24] Elevating and Safeguarding Culture Using Tools of the Information Society: Dusty traces of the Muslim culture ESCUTIS, The Educational Approaches to Virtual Reality Laboratory (EARTHLAB), http://earthlab.uoi.gr/escutis/Books/ESCUTIS_QTVR%20in%20Cultural%20Heritage.pdf

[25] Whalley P. (2003). *Interaction as enquiry: learning with layered dynamic media*. In: Rauterberg, G.M.; Menozzi, M. and Wesson, J. eds. Human-Computer Interaction: INTERACT '03. The Netherlands: IOS Press, pp. 936–939.

Improving museum visitors' Quality of Experience through intelligent recommendations: A visiting style-based approach

Ioanna LYKOURENTZOU^{a,1}, Xavier CLAUDE^a, Yannick NAUDET^a,
Eric TOBIAS^a, Angeliki ANTONIOU^b, George LEPOURAS^b and Costas Vasilakis^b
^a*Centre de Recherche Public Henri Tudor, Luxembourg*
^b*University of Peloponnese, Greece*

Abstract This paper investigates the effect that smart routing and recommendations can have on improving the Quality of Experience of museum visitors. The novelty of our approach consists of taking into account not only user interests but also their visiting styles, as well as modeling the museum not as a sterile space but as a location where crowds meet and interact, impacting each visitor's Quality of Experience. The investigation is done by an empirical study on data gathered by a custom-made simulator tailored for the museum user routing problem. Results are promising and future potential and directions are discussed.

Keywords. Intelligent recommendations, Quality of Experience, agent-based modeling, visiting styles, crowd simulation

1. Introduction

Museums; places people visit for learning, socialization and entertainment purposes. Visitors want to leave the museum having purposefully spent their time there. In parallel, museums typically have a variety of items on exhibition. What each visitor is interested in seeing varies and it can be related to their interests, learning targets, available time, as well as on other factors such as the size of the museum.

A problem often faced by museum visitors is that they often do not fully profit from their visiting experience. That is, in the course of their visit, visitors may lose time viewing items that do not interest them and miss those that do, due to time restrictions or simply to the tiredness that inevitably occurs during visits.

Missing important exhibits and viewing items that the visitor is not so much interested in may significantly lower visitor's experience. Therefore, a need exists to improve the Quality of Experience (QoE) of museum visitors through intelligent recommendations that will route visitors inside the museum towards exhibits of interest, while, in parallel, minimizing the visitors' walking time within the museum. Such an approach would contribute towards shifting the museum from a static exhibition space to what we may call an Intelligent Environment, designed to assist and improve the overall experience of the visitor. Finally, it is also very important to examine the

¹Corresponding Author.

routing and recommendations given in the *context* of the museum, i.e. taking into account the particularities of the behavior of museum visitors, which are different than a generic crowd's behaviour.

1.1 The Experimedia BLUE project

Experimedia BLUE², is a research project funded by the European Commission, to examine the above. Specifically, in Experimedia BLUE we are interested in augmenting museum visitor experience by designing intelligent recommendation algorithms that will offer a personalized visit to museum visitors according to their interests, the type of visitor that they are, but also to their personality. The experimentation setting of the project is the FHW³ museum, a technological museum situated in Athens, Greece.

Briefly, the idea is as follows: visitors can play a Facebook game, prior to their visit, which allows us to identify, with different degrees of accuracy, their interests on the museum exhibition items and themes. During their visit, we provide visitors with handheld devices that allow us to deliver recommendations over which item to visit next, but also to monitor the visitors' movement within the physical space of the museum, thus detecting their visiting style. Visiting style is an important factor reflecting people's behavior when they are inside a museum and its detection can allow us to calibrate the recommendation algorithms specifically for the museum's context. After the visit, people can share their experiences through social media. Given that different museum visitors are expected to have different levels of interest for the exhibits, different walking patterns and visiting styles, and spend varying amounts of time on exhibitions, the first thing that we wish to explore in the BLUE project, prior to any experimentation with real users, is the degree to which intelligent recommendations can improve the visitors' QoE, considering all the parameters above.

1.2 Our contribution

In this paper we investigate the potential and limitations that intelligent recommendations have on the QoE of museum visitors, when designed to optimize the latter for interesting exhibit identification and walking time minimization. We design a smart recommendation algorithm and examine its expected performance for different levels of noise in the estimation of user interests. Most importantly, given that museum visitors are divided into visiting styles, we also examine the effect that such intelligent recommendations have on each visiting style, in order to identify possible approaches, and their context, for further QoE improvements, for the specific problem of museum visit augmentation.

The difference of the BLUE approach with current approaches that use intelligent recommendations to route crowds is that typically these focus on non-museum applications such as building evacuation plans. The approaches that focus on museums usually treat them as generic physical spaces and do not take into account the visiting styles of the visitors to optimize user routing. In addition the works on optimizing user routing inside museums (indicatively [12]) usually report few quantitative results, while they do not examine factors such as noise in visitor interest estimation.

The rest of this paper is organized as follows: Section 2 presents the related literature and positions the present work within it. Section 3 presents the modeling of

² Experimedia BLUE project, <http://www.experimedia.eu/2012/10/01/blue/>

³ Foundation of the Hellenic World (FHW) museum, <http://www.ime.gr/fhw/index.php?lg=2>

the elements (museum, visitors, visiting styles, and recommendation algorithms) developed and used. Section 4 presents the experimental evaluation. Finally, section 5 discusses the obtained results, presents future work and concludes the paper.

2. Related Literature

2.1 Indoor localisation systems and location-based services

With the rise of GPS [6], localisation services have become very popular and seen a multitude of services, making good use of localisation systems, made readily available [14]. However, there is an inverse relation between the availability of the service and the need for the service as the structures we build create a shadow that cannot be penetrated by current GPS technology. Indoor localisation technologies have been developed to remedy the situation. They come in two categories: the first relies on the installation of an additional infrastructure [4; 9] while the second category aims at exploiting existing infrastructures [1; 16]. Indoor locations have since seen tailored services being developed [7]. In the scenario investigated in this paper, as well as in the BLUE project, indoor localisation technologies are to be used to capture museum visitor's positions, track their movement through a museum, and issue recommendations on their optimal path through the museum based on the visitors' personal preferences and interests.

2.2 Scenario-based user routing optimisation

In contrast to outdoor localisation systems which benefit from a very homogenous setting roads and paths are well defined and delimited clearly; indoor localisation is a bit trickier. Only part of the navigable space, notably corridors, is clearly defined. Therefore, indoor maps need to be enhanced, for example semantic information[5], to increase routing and navigation accuracy and flexibility. This will in turn enable indoor scenarios to take into account more diverse mobility types and develop specialised scenarios, e.g. for individuals with reduced mobility [8]. Due to its GPS-based scenario legacy, localisation systems focus on mobility scenarios given by physical mobility types and offer standard optimisation options (e.g. fastest, shortest) but do not account for individual's preferences, in regard to experience, to navigate spaces. However, Quality of Experience (QoE) is paramount when the objective is to experience an environment rather than merely navigating it.

Enhancing experiences through the use of technology is often proposed by using readily available, familiar, and easy to use devices. For example, the works of Andolina et al. [2] and Tesoriero et al. [15] make use of mobile devices to optimize cultural heritage visitor's experience by improvements to presentation, interaction, and integration. Unfortunately, they leave the potential for QoE improvement by interest-optimized visitor routing untapped. The work of van Hage et al. [3] approaches this problem by proposing to detect user preferences and compute a personalized visit, optimized by walking distance and the art objects that each visitor perceives as interesting. Roes et al. [11; 12] build upon the previous work by maintaining a dynamic user model and enriching the available palette of experiences by going online. However, the above works do not specify important elements such as the interest estimation accuracy and the effect that this has on the performance of the routing algorithm, nor do they take into account visitor's personalities, through their visiting styles, for the development of the recommendation and routing strategy. We think the latter are

especially crucial, and complementary to interests, for providing relevant recommendations especially tailored for museum visitors.

In this paper we examine the effect that intelligent recommendations have on the Quality of Experience of museum visitors, for differentiated conditions of the involved visitor population (i.e. behavioral/movement patterns of the visitors, differentiated interests and crowd tolerance limits), and different noise levels of the input interest estimation algorithm.

3. Methodology

We use agent-based modeling to model the behaviour of the visitors inside the museum, as well as the museum's physical space. Below we describe the modeling performed, as well as the recommendation algorithm to be examined.

3.1 Basic Element Modeling

Museum

The museum is modeled as a set of n exhibits $e_i = [e_1, e_2, \dots, e_n]$. Each exhibit represents one exhibit inside the museum. Each exhibit e_i is modelled to have a:

- *Maximum crowd capacity* M_i , which corresponds to the maximum number of people that can simultaneously visit the exhibit e_i . For example, in the case of a painting, M would mean the maximum number of people that can gather around and see the exhibit, while in the case of an exhibit that is a video-projection room, M would mean the maximum number of seats available.

Each exhibit also belongs to one museum *room*. Therefore exhibits can either be co-located in the same room or they can be located in different rooms. Each exhibit is "connected", i.e. accessible via walking, to all the exhibits of the same room. Also, in this specific modeling, each room has one exhibit connected to the museum *entrance*, as this is the case for FHW (all exhibition rooms are accessible directly from the entrance without the need to pass from other rooms first). A room may be connected, always through exactly one exhibit, to another room. To model the above, we define:

- An $|E| \times |E|$ exhibit positioning matrix $P = [p_{11}, \dots, p_{|E||E|}]$. Each element p_{ik} of the positioning matrix P can be defined as follows:

$$p_{ik} = \begin{cases} 2, & \text{if } e_i \text{ and } e_k \text{ connect two different rooms} \\ 1, & \text{if } e_i \text{ in the same room with } e_k \\ 0, & \text{none of the above} \end{cases} \quad (1)$$

- An $|E| \times |E|$ exhibit distance matrix $D = [d_{11}, \dots, d_{|E||E|}]$. Each element d_{ik} of the positioning matrix D can be defined as follows:

$$d_{ik} = \begin{cases} -1, & \text{if } p_{ik} = 0 \\ d, & \text{if } p_{ik} = 1, \text{ with } d_{\min} \leq d \leq d_{\max} \\ d_R, & \text{if } p_{ik} = 2, \text{ with } d_{R\min} \leq d_R \leq d_{R\max} \end{cases} \quad (2),$$

where d is the distance of exhibits within the same room, and d_R is the distance between rooms, which is taken as the distance between the two exhibits connecting the rooms. Finally, for each room we also define inside each room a pseudo-exhibit, which serves as the room's center and will be used for the modeling of the movement of certain visitor types (detailed in section 3.2).

The positioning matrix is used to find the connections between items of the same room and between rooms and the distance matrix is used to calculate the path distances. These two matrices can be given, if we want to experiment on a specific museum setting, or they can be generated using the following four parameters: 1) min and max exhibits distances for the exhibits of the same room, 2) min and max room distances 3) number of total rooms in museum and 4) number of exhibits per room. The simulation described here use the above 4 parameters to generate museum settings.

Visitor

Visitors are modeled to arrive to the museum with an inter-arrival rate μ , randomly distributed between two time parameters: $\mu_{min} \leq \mu \leq \mu_{max}$.

Each visitor j has the following characteristics:

- *Interest per Exhibit* $I_{e_{ij}}$, $0 \leq I_{e_{ij}} \leq 1$, where $I_{e_{ij}}$ is a Real number and the bounds 0 and 1 mean respectively no interest or perfect interest for exhibit i .
- *Crowd Tolerance* C_{ij} . The number of other people that the visitor can handle around exhibit i , without a decrease of his satisfaction from the visit. It is modeled per exhibit, as a percentage of the maximum crowd capacity of the latter, i.e.: $C_{ij} = p_{ij} \cdot M_i$, where M_i is the maximum capacity of exhibit i .
- *Maximum available Time* T_j , in minutes. The time that the user can spend inside the museum. The simulator starts counting the moment the visitor enters. Once it is over, the visitor exits the museum.
- *Walking speed* S_j , simulated in meters/second. Will be used to calculate the time needed to go to an exhibit, in the QoE function.
- *Time spent per Exhibit* $t_{e_{ij}}$. We assume that the time each user will spend seeing each exhibit is a function of their interest for that exhibit:

$$t_{e_{ij}} = f(I_{e_{ij}})$$

, where f is defined separately for each visitor type, and described in detail in section 3.2. Regarding time, each visitor also has a *maxExhibitTime* and *minExhibitTime* correspond respectively to the overall maximum and minimum times that the user can spend on one exhibit.

- *QoE*. Each user has a Quality of Experience metric. This measures how satisfied the user is from his visit inside the museum. We can intuitively assume that for each item the user visits, his QoE is proportional to the user's interest on the item, and inversely proportional to the time it took him to reach the exhibit. Therefore, for a user j that is currently at exhibit e_k and he is going to exhibit e_i , we model $QoE_{e_{ij}}$ as follows:

$$QoE_{e_{ij}} = w_1 \cdot I_{e_{ij}} + w_2 \cdot \left(\frac{1}{walkTime_{e_{ij}}} \right) \tag{3}$$

, where $0 \leq w_1, w_2 \leq 1$ are calibration weights and $walkTime_{e_{ij}} = \frac{d_{ik}}{S_j}$ and d_{ik} is the distance between the current exhibit e_k and exhibit e_i . For the

simulations, $I_{e_{ij}}$ and $\left(\frac{1}{\text{walkTime}_{e_{ij}}}\right)$ are also normalised in the $[0,1]$ range. Finally, the total Quality of Experience QoE_j at the end of the visitor's visit is:

$$QoE_j = \sum_{i=1}^n QoE_{e_{ij}} \quad (4)$$

3.2 Visiting styles modeling

Apart from the above basic characteristics, each museum visitor belongs to one of 4 distinct visiting styles described using animal metaphors (ant, butterfly, fish or grasshopper). Each visiting style corresponds to a specific movement pattern of the visitor inside the physical space of the museum. Including the visiting styles into the modeling renders the simulations more tailored to the specific context of museum visit applications and further supports its reliability in supporting decision-making based on the simulation results. For the modeling of the visiting styles we use two literature studies. The first, the work of Veron and Levasseur [10] describes visiting styles from a behavioral perspective. The second, work of Sookhanaphibarn and Thawonmas [13], is among the few who perform a mathematical modeling of each visiting style, limited however only to one exhibition room and using x, y coordinates instead of a graph-based model that we employ. In the following we extend the aforementioned modeling to fit the graph-based model that we use.

Ant

Ant visitors move linearly, visiting almost all exhibits, showing interest in the detail, avoiding empty spaces and following a clear path and the curator's suggestions. In modeling terms, the ant visitor visits the exhibits of each room sequentially, choosing the each time closest not-visited exhibit until all exhibits of the room have been visited. The ant's interest $I_{e_{ij}}$, with i the exhibit and j the visitor, is given by a normal distribution, in the $[0,10]$ range and mean equal to 5. Also, the ant has very low interest for room centers, meaning that Ant visitors do not frequently pass from these points but they rather visit exhibits in a linear fashion. The time spent per exhibit is $t_{e_{ij}} = f(I_{e_{ij}}) = I_{e_{ij}} \cdot e^{-\rho\left(\frac{C_i}{M_i}\right)}$, where j is the visitor, C_i is the current crowd around the exhibit i , M_i is the maximum crowd capacity of the exhibit and ρ is a weighted constant used as defined in [13].

Fish

Fish visitors move in the center of rooms, seeking to see the "larger" picture, not approaching most exhibits and not stopping very frequently. Their interest $I_{e_{ij}}$ is modeled the same as that of ants, with the difference that a Fish visitor has also very high interest for room centers. This means that Fish visitors will spend a lot of their time and pass often from room centers and then, visit certain exhibits according to their interest. Fish also are modeled to return to the center after each exhibit visit and after exiting a room, they choose not to visit the centers of rooms that they have visited, to avoid eternal loops in their movement pattern (induced by their high interest for centers rather than for any other exhibit in each room). The time spent per exhibit for the Fish is $t_{e_{ij}} = f(I_{e_{ij}}) = I_{e_{ij}} \cdot e^{-\rho\left(1-\left(\frac{C_i}{M_i}\right)\right)}$, where i, j, ρ, C_i, M_i are defined as in the previous.

Grasshopper

Grasshopper visitors are persons of particular interests, they only approach certain exhibits, cross empty spaces and spend a significant amount of time in front of items of interest. To model those exhibits that are of interest for the Grasshopper, we use a Beta PDF distribution with $\gamma = 1$ and $\beta = 5$, as in [13]. Then applying a threshold L , we select the exhibits that the Grasshopper will be interested in. For these exhibits, we model an interest $I_{e_{ij}}$, given by a Gaussian distribution but with a mean very close to 1, to model the very high interest that the Grasshopper has on these exhibits. For the rest of the exhibits, the Grasshopper has 0 interest. The time that the Grasshopper spends per exhibit is also affected by the above-selected exhibits as follows:

$$t_{e_{ij}} = \begin{cases} I_{e_{ij}} \cdot e^{-\rho\left(\frac{C_i}{M_i}\right)}, & \text{if } I_{e_{ij}} > L \\ 0, & \text{if } I_{e_{ij}} < L \end{cases} \quad (5)$$

, where L is the threshold on the Beta distribution, and the rest of the parameters are defined as in the previous.

Butterfly

Butterfly visitors move nonlinearly, they do not follow the curator's suggestions, they often change the direction of their movement, approach exhibits, are interested in the detail and are affected by environmental affordances, such as the accessibility of the exhibit. The Butterfly visitor is modeled to also present a selective exhibit probability, like the case of the Grasshopper, but on the inverse, i.e. a Butterfly is interested in most of the exhibits. To model the exhibits of interest for the Butterfly we use a Beta PDF distribution with $\gamma = 5$ and $\beta = 1$, as in [13]. Again placing a threshold L , low this time, we define the exhibits that the Butterfly has interest in. The exhibits underneath this threshold present a 0 interest for the Butterfly. For the selected exhibits we use a Gaussian distribution with mean equal to 7. The time that the Butterfly spends per exhibit is defined to be similar to that of the ant for those exhibits with $I_{e_{ij}} > L$ and 0 otherwise.

3.3 Modeled Systems

We model two systems implementing two kinds of visitor behaviour in the museum:

- *Simple visit.* Visitors enter the museum and select exhibits to see, according to their visiting style. For each visitor, if the exhibit he/she selects has reached its maximum crowd capacity M_i , or it has more visitors than the crowd tolerance limit of the specific visitor, then he/she moves to another exhibit. For going from one exhibit to the other, visitors always take the shortest path. The resulting simulated system, with its 4 subsystems (one for each visiting style) is referred to as the “no recommendation” system and serves as the benchmark.
- *Recommendation-based visit.* Visitors in this system are given exhibit recommendations, through a recommendation algorithm (described later on). In case the algorithm recommends them an exhibit for which their estimated interest is above 7 (in a scale of 10): $I_{e_{ij}} > 7$, then they follow the recommendation. Otherwise they behave like in the random system, i.e. they randomly select an exhibit. It should be noted that the algorithms makes its

recommendations based on the estimated interest of the user, which is modeled as the real interest of the user plus noise. The noise, which basically models the approximation error that the algorithm will have in reality, is set by the "noise" parameter of the simulator, as a range between two numbers, each in the scale of $[0,10]$, since interest is also measured in this scale. Then before each recommendation, the algorithm selects a random number in the range set for the noise and adds/subtracts it from the real user interest. This estimated value is the one used for the recommendation decisions of the algorithm. Example: Assume we set noise to be in the $[1,2]$ range and a user with real interest $7/10$. This means that the best possible approximation of this user's interest is 7 ± 1 and the worst possible is 7 ± 2 . Therefore the algorithm estimates the user's interest as a random number in the $[5,6]$ or in the $[8,9]$ ranges. The recommendation algorithm used in the specific paper is as follows:

- o "*Smart*" algorithm. The algorithm optimizes for the QoE function, as given in eq. (4). This is the classical content-based recommendation scheme where the recommender takes into account user interests and walking time to try to maximize the user satisfaction.

4. Experimental evaluation

In the following we present certain preliminary results, derived from simulating an environment that features the modeling presented above. The modeling parameters chosen for the specific experimental evaluation, and for the purposes of the BLUE project, are illustrated in Table 1.

Table 1. The parameters used in the scenario evaluation

Parameter	Value
General Parameters	
Runs per result	20
Noise input to recommender	0-10/10
Total simulation time	18,000 units
Visitor parameters	
Maximum available Time	[1800, 5400]
Walking speed	[0.83, 1.83]
Time spent per Exhibit	[60, 500]
Visitor inter-arrival rate	120
Crowd tolerance	[0.7, 1]
Museum parameters	
Exhibit distance (in the same room)	[2, 5]
Room distance	[100, 500]
Exhibit crowd limit	[4, 10]
Number of rooms	5
Exhibits per room	6

4.1 Results

First we measure the QoE between the simple and smart systems, for different levels of recommendation noise (i.e. the error between an ideal recommendation and the one actually provided by the system). This first scenario answers the basic question of whether a QoE-based recommendation increases the QoE of the visitors and, if so, by how much. The recommendation algorithm being deployed in the FHW museum will

inevitably have an approximation error (regarding its estimation of user interest per exhibit). Therefore, this scenario mirrors the QoE improvements that we expect when accounting for the algorithm's approximation error.

As we can see in Figure 1, the recommendation noise directly affects the level of visitor QoE, for all 4 types of visitors, since it affects the accuracy of the recommendation algorithm. In other words, the more inaccurate the algorithm's estimations, the lower its final average visitor QoE. This is expected as QoE is computed from the fulfillment of user interests. The very high levels of noise, for example above 7, of the Figure correspond to the "worst case scenario" accuracy error that may be encountered for visitors that have not used the Facebook game and, therefore, their profiles are unknown to the algorithm when they first enter the museum. As they gradually move and respond to recommendations, we can expect that the recommendation algorithm's accuracy error will drop. However, in both cases (for high and low noise) we observe that the visitor's QoE is higher than the previously established baseline, where visitors move based only on their visiting type without any recommendations.

Other interesting results can be observed when examining the gain in QoE for each visiting style on its own. As we have observed, the type of visitor that can be expected to receive the highest improvement of experience is the Fish (Fig. 1a), followed by the Ant (Fig. 1b). Butterfly type visitors (Fig. 1d) and Grasshoppers in particular (Fig. 1c), only show a slight, to almost no improvement in QoE when a recommendation algorithm is used. This can be explained by the fact that Fish, typically moving in the center of the exhibition rooms, may accidentally "miss" many exhibition items. Hence, directing them towards specific items of interest significantly improves their overall QoE. The same goes for Ants and Butterflies, although to a lesser extent, as these visitors show, inherently, a more uniform distribution of interest for items inside the museum. Finally Grasshoppers, being visitors that have a very high interest in very specific exhibits, will visit these exhibits regardless of the external conditions of the museum space (e.g. other visitors) or interest-based recommendations.

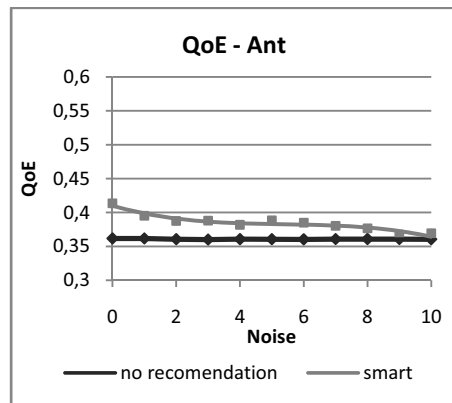
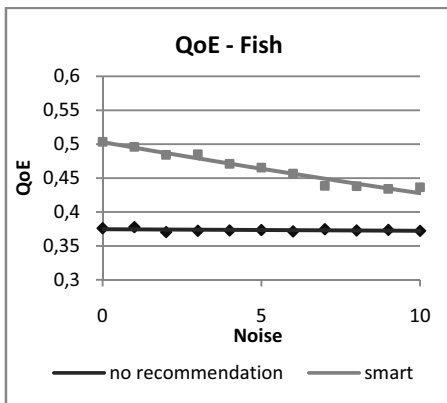

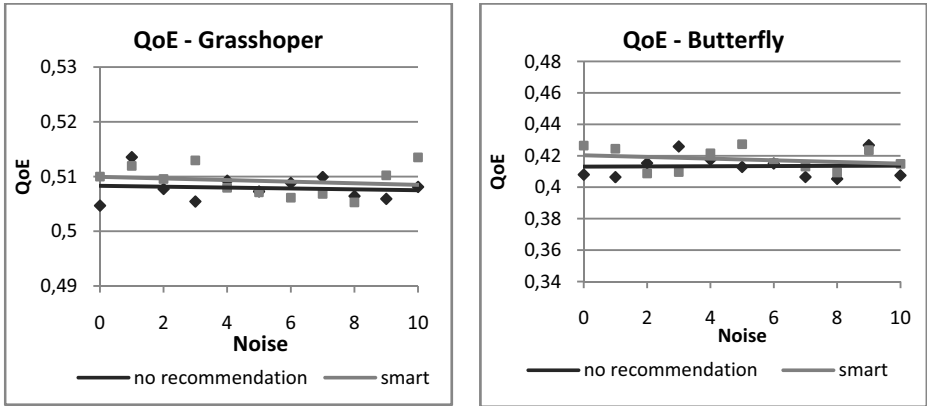
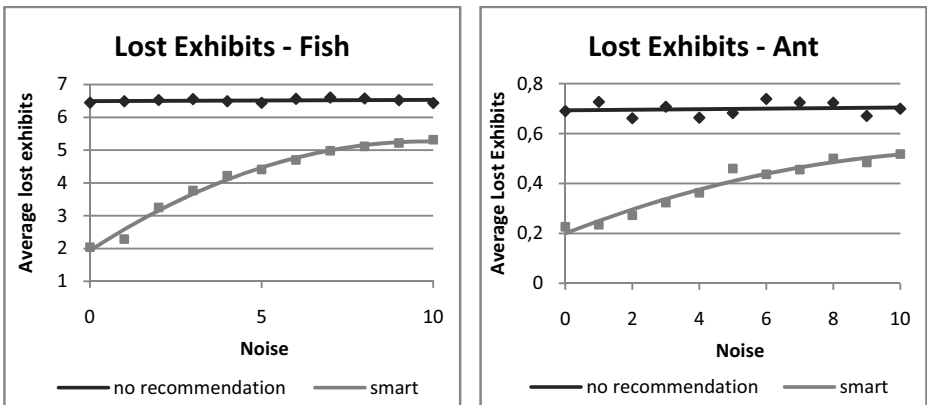

Figure 1. Quality of Experience achieved with and without recommendations

Figure 2 depicts the number of missed exhibits for different ranges of noise in the recommendation algorithm's estimations. Missed exhibits are those that the visitor is very interested in (internal interest > 7 on a scale of 10) but that he does not see because they are not recommended by the algorithm due to high estimation noise. As expected, the higher the noise, the higher the number of lost exhibits. However, we also observe that, at all noise levels, the recommendation-based system does not result in a significantly lower number of missed exhibits, thus the loss of QoE for visitors, even at high levels of approximation error, is acceptable.

Analyzing the results per visitor type we witness the same pattern as before, i.e. that Fish are expected to benefit the most from the recommendation of exhibits by the smart algorithm, while Grasshoppers benefit the least. Ants and Butterflies innately miss very few exhibits, with Ants seeming to benefit the most, among the two visiting styles.



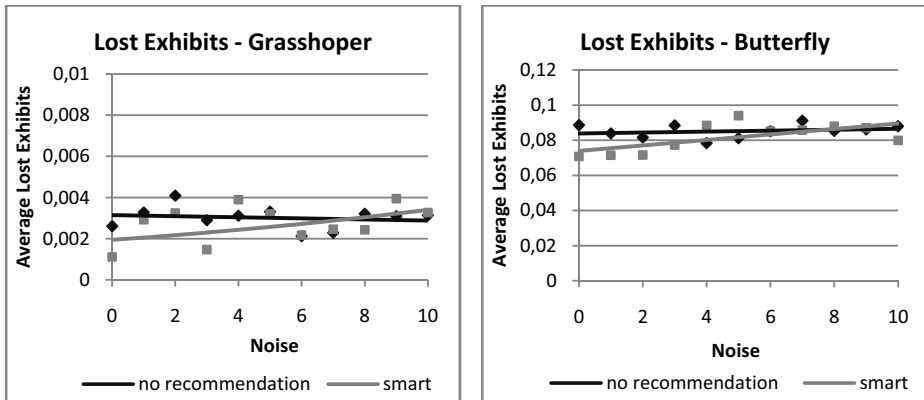

Figure 2. Average number of missed exhibits with and without recommendations

5. Discussion, Future Work and Conclusion

In this paper we examine the effect that intelligent recommendations (designed to improve QoE and reduce walking time) have on the QoE of visitors belonging to the 4 prevalent behavioral and movement patterns that literature gives us for museum visitors. To do so, we model in detail the museum setting, the behavioral and movement patterns of museum visitors, including their visiting styles, as well as the recommendation algorithm. We then examine, through simulation evaluation, the effect of the algorithm on the QoE on the visitors. Experimental results show that Fish is the type of visitors that can benefit the most, since their QoE considerably improves after receiving interest-based routing recommendations. Ants and Butterflies can also be helped although not as extensively as the Fish. The Grasshopper is the type expected to profit the least from such an algorithm, mainly because Grasshoppers know a priori which exhibits they would like to see, regardless of interest estimation or distance. The noise in the estimation of visitor interests was found to play an important role in the efficiency of visitor routing, further supporting the need for accurate a priori interest estimations like the one we use in the BLUE project through the Facebook game visitors can play before visiting. Noise, however, even at very high levels, was not found to worsen QoE when compared to giving no recommendations. This is positive, as it can provide more flexibility in experimentation with various recommendation strategies.

Having a good base for the modeling and simulation of the 4 different visitor's types, in the future we would like to develop and examine recommendation algorithms that are tailored and adapted to each style separately. Perhaps in this way we may achieve further improvement on visiting types like the Butterfly or the Grasshopper that seem to experience a low benefit from the generic interest-based recommendation algorithm used in this paper. Another interesting data point would be to measure the QoE not per visitor but per exhibit to examine the distribution of user "satisfaction" with each exhibit. This could allow museum curators to optimize their exhibitions by potentially re-arranging exhibit items within the physical space of the museum, according to the visitor types that the museum most often hosts. We also plan to examine visitors' response to recommendations when museums of different size and exhibit density are concerned. Furthermore, we intend to extend the present work to

mixed crowd scenarios (populations of different visiting styles, or populations where some visitors receive recommendations and others do not), as well as on visitor groups (such as families of school classes) rather only on individual visitors. Validation with real users in a selected museum scenario is also envisaged.

Finally, it would be interesting to observe the effect that crowd congestion has on the QoE of the different visiting styles. We are currently examining the algorithm's response in relation to different congestion levels inside the museum, in order to come up with intelligent routing algorithms that optimize the visitors' QoE for congestion as well.

Acknowledgements

Research carried out in the context of this paper has been partially funded by the Experimedia project (Experiments in live social and networked media experiences) within the European Seventh Framework Program (ICT-2011.1.6). The work of I. Lykourantzou in this paper is supported by the National Research Fund, Luxembourg, and co-funded under the Marie Curie Actions of the European Commission (FP7-COFUND).

References

- [1] Mobile Indoor Localization, Microsoft Research, <http://research.microsoft.com/en-us/projects/indoorloc/>, Retrieved: May 3, 2013.
- [2] S. Andolina, D. Pirrone, G. Russo, S. Sorce, and A. Gentile, Exploitation of Mobile Access to Context-Based Information in Cultural Heritage Fruition, in: *Broadband, Wireless Computing, Communication and Applications (BWCCA), 2012 Seventh International Conference on*, 2012, pp. 322-328.
- [3] L. Aroyo, G. Antoniou, E. Hyvriinen, A. Teije, H. Stuckenschmidt, L. Cabral, T. Tudorache, W. Hage, N. Stash, and Y. Wang, Finding Your Way through the Rijksmuseum with an Adaptive Mobile Museum Guide, in: *The Semantic Web: Research and Applications*, Springer Berlin Heidelberg, 2010, pp. 46-59.
- [4] P. Bahl and V.N. Padmanabhan, RADAR: an in-building RF-based user location and tracking system, in: *INFOCOM 2000. Nineteenth Annual Joint Conference of the IEEE Computer and Communications Societies. Proceedings. IEEE*, 2000, pp. 775-784 vol.772.
- [5] M. Goetz and A. Zipf, Formal definition of a user-adaptive and length-optimal routing graph for complex indoor environments, *Geo-spatial Information Science* **14** (2011), 119-128.
- [6] B.L. Hofmann-Wellenhof, H.; Collins, J., *Global Positioning System. Theory and practice*, Springer, Wien (Austria), 1993.
- [7] H. Karimi, Indoor Navigation, in: *Universal Navigation on Smartphones*, Springer US, 2011, pp. 59-73.
- [8] H.A. Karimi and M. Ghafourian, Indoor Routing for Individuals with Special Needs and Preferences, *Transactions in GIS* **14** (2010), 299-329.
- [9] C. Kee, D. Yun, H. Jun, B. Parkinson, and S. Pullen, Centimeter-accuracy indoor navigation using GPS-like pseudolites, *GPS WORLD* (2001).
- [10] E.V.a.M. Levasseur, Ethnographie de l'exposition: l'espace, le corps et le sens, in: Centre Georges Pompidou, Paris: Bibliothèque Publique d'Information, 1989.
- [11] I. Roes, *Personalized Museum Tour with Real-Time Adaptation on a Mobile Device with Multi-Point Touch Interface*, Mater Thesis, Eindhoven University of Technology, 2010.
- [12] I. Roes, N. Stash, Y. Wang, and L. Aroyo, A personalized walk through the museum: the CHIP interactive tour guide, in: *CHI '09 Extended Abstracts on Human Factors in Computing Systems*, ACM, Boston, MA, USA, 2009.
- [13] K. Sookhanaphibarn and R. Thawonmas, A Movement Data Analysis and Synthesis Tool for Museum Visitors' Behaviors, in: *Proceedings of the 10th Pacific Rim Conference on Multimedia: Advances in Multimedia Information Processing*, Springer-Verlag, Bangkok, Thailand, 2009.
- [14] S. Sukkarieh, E.M. Nebot, and H.F. Durrant-Whyte, A high integrity IMU/GPS navigation loop for autonomous land vehicle applications, *Robotics and Automation, IEEE Transactions on* **15** (1999), 572-578.
- [15] R. Tesoriero, J.A. Gallud, M. Lozano, and V.M.R. Penichet, Enhancing visitors' experience in art museums using mobile technologies, *Information Systems Frontiers* (2012), 1-25.
- [16] A. Varshavsky, E. de Lara, J. Hightower, A. LaMarca, and V. Otsason, GSM indoor localization, *Pervasive and Mobile Computing* **3** (2007), 698-720.

Playing in museums by constructing your game

Ines DI LORETO^a, Monica DIVITINI^a, Igoris TRIMAILOVAS^a, Micaela MANDER^b

^a*Department of Information and Computer Science, Norwegian University of Science and Technology, Trondheim, Norway*

^b*Scuola della Comunità Ebraica di Milano, Liceo "Com. Federico Jarach"*

Abstract. In this paper we present MagMAR, a system for supporting museums visits recognizing the different needs of educators and students. MagMAR combines a Mobile Augmented Reality game (targeted towards young visitors) and a Web interface (targeted towards educators). The Web interface lets educators shape and guide the learning process, while the game is intended to engage students during the visit. A first evaluation was performed asking 9 students and a teacher from a high school class to test a MagMAR in a contemporary art museum in Milan. Results show that the form game was very successful from the sociability and fun points of view, and also guided the students in the retrieval and usage of information for the quiz game. Further improvements are on the other hand due to make the game more integrated in the context and push the students to pay more attention to their surroundings.

Keywords. Serious Games, Augmented Reality, Young people

1. Introduction

Along the years, access to culture has changed forms. Starting from the '60ies in parallel with classic channels and institutions we have seen the emergence of youth culture channels (see e.g., [1] for a detailed analysis on the topic). These channels are dynamic and often informal, and many times do not enjoy official recognition (for example in the case of street art) [2]. In addition, the way young people accumulate, analyse, and disseminate information and knowledge today is strongly connected to new technologies [5]. Opportunities for young people to enlarge their cultural and creative expressions and development - in or outside of school - can thus pass through the usage of technologies.

Within the museum and culture research literature, there has been some emerging focus on how digital devices improve engagement to enhance the visitor's experience. For example, [6] tested a prototype handheld device that delivered descriptions of artefacts in a historic house to multiple users simultaneously, and found that conversations around exhibits increased. In another study, increased engagement and interest was also found with young students when they were given RFID sensors that could detect exhibit locations and unlock virtual information to extend their interactions [7]. Along similar engagement lines, other studies have examined how Augmented Reality (AR) can improve access to information and increase exhibit functionality. For example, [8] investigated the functionality of an AR-enabled mobile multimedia museum guide implemented in a fine arts museum in France. They found,

among other things, that using AR to enhance the museum experience could serve as a viable alternative to traditional text guides in retrieving information, which has potential to attract new audiences.

In this paper we present MagMAR, a system for supporting museums visits recognizing the different needs of educators (e.g., teachers and museums' guides) and students. MagMAR combines a Mobile Augmented Reality game (targeted towards young visitors) and a Web interface (targeted towards educators). The usage of MagMAR in museums and other cultural heritage settings is expected to enhance the fruition experience and reconnect young people to cultural heritage, letting nevertheless the educators able to monitor the learning cycle. The rest of this paper is structured as follow. Next Section and Section 3 describe respectively the motivations and the design principles that guided us towards the creation of MagMAR. Section 4 drafts a short state of the art while Section 5 and 6 describe the MagMAR design and a first evaluation we held with teenagers in a museum setting.

2. Motivations

In [4] the authors narrate an ancient anecdote. When the Spanish galleons arrived for the first time off the coast of the islands in Central America the Indians were not able to see them, as they were objects so far beyond their experience and their ability of understanding to make them in all respects "invisible". Only after a prolonged (and traumatic) contact with the new culture galleons finally became visible and could be integrated into patterns of behaviour, language, and in everyday experience. For many citizens local heritage (museums but also other structures) sometimes seems to enjoy features of invisibility comparable to those of the galleons of the story [4]. In line with [2] the authors of this paper believe that non-formal arts education approaches can be profitably used together with other types of formal approaches to reconnect people - and in particular young people - to culture, making cultural heritage visible to them. In addition, in a recent EU document[15]educators are asked to teach the students strategies and methods to be applied independently from school (the "know how"). This approach urges teachers to lead students outside the classroom, going to museums, on excavation and construction sites, investing time to put students "in situation" and enabling them to "learn by doing"[16]. Creating these possibilities takes time, tools, resources, interdisciplinary connections, and methodological experimentation. Among other things, this approach requires teachers to acquire skills that transcend the role assigned to them by the school until today. These skills, if already present, were acquired in most cases through "informal and non-formal" paths [16].

The two scenarios we described suggest the need to integrate informal learning in formal settings at two levels, the students' and the teacher's one. The approach we propose in this paper, MagMAR, is composed by an augmented reality game targeting young people and a web application targeting educators. These two elements are strictly linked together, enabling the usage of informal learning at both levels.

3. Design for Young People Access to Culture

In this section we describe some additional considerations which drove us in the creation of the MagMAR application.

3.1. *It's all about the form: the invisible museum and its non-public*

The youth population is, according to the cliché, a *non-public* for the cultural offer, or at least an audience motivationally weak and discontinuous. In study [8] the authors analysed the perceived image of museums targeting teenagers. What emerges is their generally negative connotation. The most used adjective in the conducted survey is *old-fashioned*, and the museum image is linked to the concepts of closure, normativity, distance. What is interesting in this study is that many of the factors that create this connotation are completely unrelated to the content but related to the *form* of the museum. Quality of the experience as a whole, rules of conduct and explicitly didactic value, but also lack of communication or inadequate equipment, are equally if not more important than the content of the collections in forming the judgment of young people towards the experience related to the museum.

3.2. *It's all about emotions 1: sense of belonging and sociability*

A second study targeted at teenagers [3], has clearly highlighted that young people perceive a great distance between the so-called “high” culture and the youth culture which is considered to be “popular”. The most successful initiatives at the level of youth culture proposed by traditional cultural institutions are those in which this distinction is not marked. Moreover, the most vivid, positive, and persistent memories of the museum are those attributable to strong emotions felt during a visit (the emotional dimension is predominant with respect to the cognitive in determining the value of the experience). More specifically what emerges is the deep need for comparison and relationship with others, a dominant socio-relational behaviour that informs the processes of choice, the formation of tastes, and the evaluation of the experience. While the typical adult visitor of museums gives the museum a value in itself (intrinsic dimension), is self-referential (in the sense that the visitor’s experience is individual)[9] and tends to have a reactive attitude towards the objects on display, for the interviewees seem to play a significant role the ensemble of environmental, socio-relational, and emotional factors more than the actual contents.

3.3. *It's all about emotions 2: ownership and content*

Recent technology, and especially the Web 2.0, offers people the possibility to become involved in activities that are called End-User Development (EUD), i.e. activities that range from simple parameter customization to modification and assembling of components, and even to the creation of new software artefacts [10],[11],[12]. Today, users are no longer passive consumers of computer tools, but they are more and more information and software producers. These new roles of end users blur the distinction between design time and use time in the life cycle of an interactive system. In addition, in [17]the authors highlight that the learning potential in the field of technology enhanced learning is not only linked to game play but also to game design and development (see also [13] [14]).

To summarize, form, ownership and sociability seem to be factors of engagement in exploring cultural heritage and in particular museums.

4. State of the Art: Games for Cultural Experience

Previous section clearly states that the form is an important factor for the engagement of the young population. In this section we describe why we opted for an augmented reality game as an alternative form of exploration in the museum setting.

Games, learning and cultural heritage

Recent studies have shown that the introduction of games has the potential to help young visitors to use the information gained during a cultural tour in a more meaningful way [21] as it obliges the young visitors to use the collected information right away to complete some tasks or answer some questions. In addition, young visitors are most likely used to play video games and are familiar with multiple platforms to play them on. Introduction of a video game in the cultural setting might thus provide a natural environment for the young visitors [22]. Indeed, game play is not a new practice for museums. Through the years a lot of (non-technological enhanced) educational games have been created for museum or other cultural settings. The main idea behind these games was to make the experience for the young visitors more interesting creating an environment where they could learn through interactivity. One typical example of these games is the “treasure hunt”, where participants are asked to find in the museum different items and answer a couple of questions about the same by filling in a paper form. The team who answers in the right way and fastest wins.

Augmented Reality

For the game described in this paper we decided to focus on the usage of *Mobile Augmented Reality (MAR)*. The main advantage of the AR technology is that it is created to supplement the real world with virtual objects that appear to coexist with the real world. By providing more intuitive and natural means of interaction AR has the potential to further blur the line between computer generated content (for example pc games) and the real world. In addition, the field of AR applications for culture has grown a lot in recent years due to rapid development in handheld devices technology, resulting in a new sub field of augmented reality called *Mobile Augmented Reality (MAR)* [18]. MAR’s popularity today is tightly linked to the availability of smartphones that can exploit its capabilities and enhance user experience while remaining relatively cheap. Researches were conducted also about the usefulness of augmented reality to enhance visitor experience in the museum setting as MAR has the potential to give users more visual information about the items in the museums or even augment the items themselves [19]. However, current widespread applications are mainly targeted at tourism, creating interactive guides for the city or visual augmentation for exhibitions (i.e. to show how a site looked long time ago or how an item was used). Finally, from a learning point of view [20] findings suggest that the usage of AR in a cultural setting might have an impact on conceptual knowledge.

Augmented Reality and Games in Museum Settings

The introduction of digital technologies in cultural settings resulted in revisiting more in general the idea of game play/storytelling in museums (for a detailed presentation and overview see [23]). For this paper, however, we will focus only on the

attempts to bring mobile *augmentation* into the museum setting for educational purposes. In [24] the game itself is an implementation of a classical “Scavenger Hunt” game. A Scavenger Hunt is a game in which the organizers prepare a list defining specific items. The participants seek to gather all items on the list, or perform tasks, or take photographs of the items, as specified. The goal is usually to be the first to complete the list, although in a variation on the game players can also be challenged to complete the tasks on the list in the most creative manner. In [24] users played the game by answering the questions provided by the system. To find the correct answers, they had to explore the museum and find relevant information about one of the items found in the museum. The project was strongly influenced by the technological difficulties that the PDA’s provided (by that time handheld PDA’s had almost no processing power and little to no memory). However, despite the slow hardware, participant interviews indicate that players enjoyed the experience which proved to be not only entertaining but also educational.

Other studies indicate that the usage of MAR has various advantages over using Virtual Reality simulations for educational purposes mainly due to human perception of our surroundings and the ability to relate to the content of the application [19]. This research supports the idea that by moving around the museum, trying to find the items using the mobile phone camera instead of just getting a list of questions might improve user engagement. Another research on the usefulness of educational games was conducted by [21]. By implementing interactive games in museum setting for PDA’s and observing how people interacted with them, the researchers concluded that when children can use the information gained in the museum immediately to play a game the museum experience can be both educational and entertaining.

Finally, the most recent and relevant attempt we can describe is the Mobile Augmented Reality Quest [25]. MARQ is a team-oriented game to provide an AR museum tour. It is targeted at young visitors (age 12-16), who have to explore the museum by solving interactive 3D AR puzzles to reveal parts of the story. The game uses interactive visual and audio augmentation to make the visitors experience as rich as possible. This game supports multiple user interaction by sharing the collected items between players and tracking the position of the players.

5. The MagMar Design

MagMAR combines a mobile game (targeted towards young visitors) and a Web interface (targeted towards teachers). The Web interface lets teachers shape and guide the learning process, while the game is intended to engage students during the visit.

During the visit, students divide into teams to play the game, while teachers can monitor the progress. After the visit, the information is available to students and teachers to reflect about the museum experience. The actual game consists in a digital implementation of a Treasure Hunt game which replaces the pen and paper with an Android device and a Mobile Augmented Reality (MAR) application developed through the Qualcomm Vuforia framework.

One of the main elements which differentiates MagMAR from the games illustrated in the state of the art is the usage of user generated content not only before the beginning of the game for a set up phase, but also during the actual game session. In the first phase, the educator can decide which information will be available to

students as starting point, taking into account e.g., the learning objectives of the visit and the knowledge level of the students. In the second one, students will create contents in form of questions for the game. The main idea behind this design choice is to use the emotional element of ownership which is typically linked to hand-made objects [26] (the questions are valuable because they are created by the members of the team) also for engaging the students in the museum exploration.

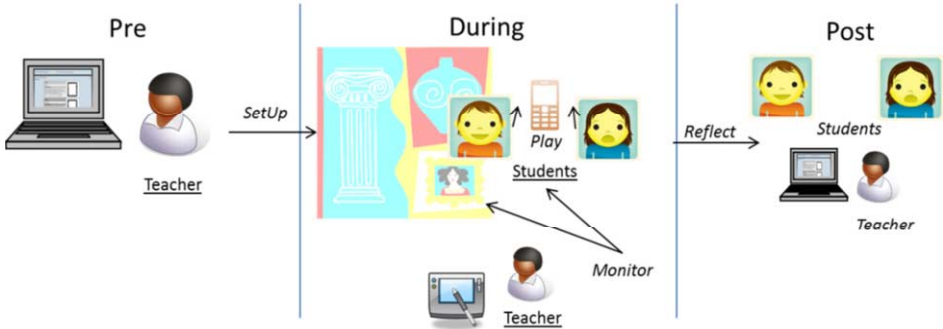

Figure 1. An overview of MagMAR intended usage

In the following we explain the three phases more in details, referring to the current implementation of the system.

Phase 1: The set up

The educators use a Web interface to specify the objects of the game on which they want to focus during the visit and provide related information (Fig. 2). The number of items to be used in each game is flexible as it can be influenced by the size of the museum or other limitations as time or item relevance. The teachers can not only decide which elements are relevant but also the given amount of information, which can vary from a short item description - only sufficient to identify the item – to a more complex description providing some generally known facts about the item (author, when it was created etc.).

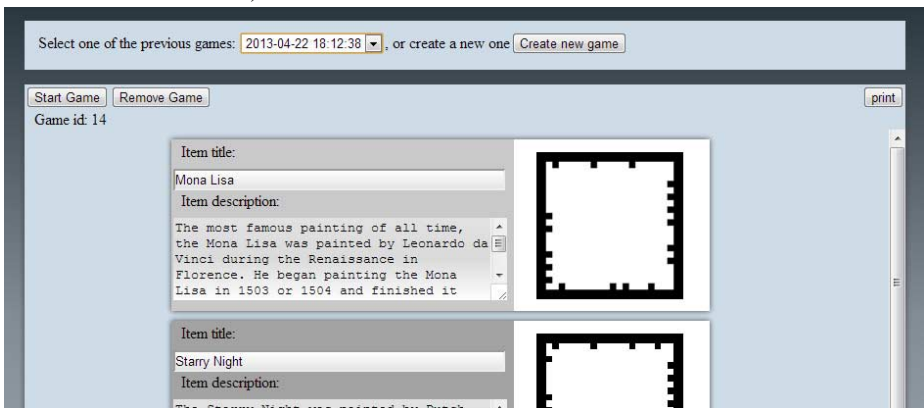

Figure 2. Web interface

For each item, the system generates a physical marker, a small unique pre-programmed picture that is used to identify an item in the physical world and access the related information. Once this phase is over the educator will print out the markers, cut

them out, and head with the class to the museum. Before the actual game session the educators have to manually put all the markers in the vicinity of the corresponding museum items (see Fig.3). In case this is not possible they can simply print out the images associated to the markers and use them while going around in the museum. The information entered by the educator in the Web interface is visible through the MAR application installed on the mobiles (see Fig.3). The visual augmentation is used to create an anchor between the physical item and the augmented dynamic information (firstly the one created by the supervisor, in a second moment the questions created by the students).

Phase 2-a: The game session: Supervising the visit

Once the preparation is over, the game can start. To start the game the educators open anew the Web interface on their personal device, select the previously created game, and start it. The system goes then into a listening mode and waits for the players to join the game. The Web interface allows also for real time game monitoring. This means that during the game session the educator can view in real time the questions created by the players, which provides an overview of the game progress. If the supervisors are not happy with the questions created they might ask the players e.g., to try harder and create the question again.

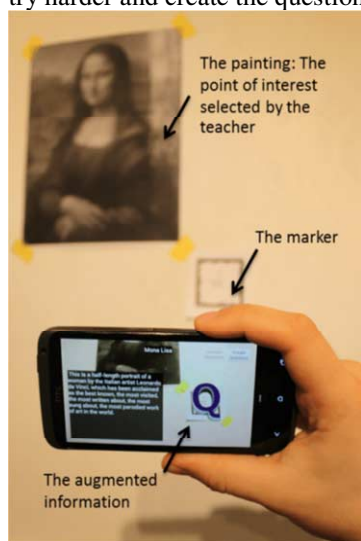

Figure 3. Interacting with markers

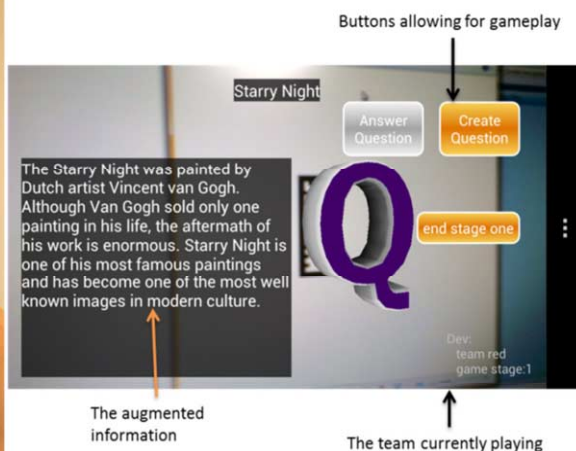

Figure 4. The question/answer process

Phase 2-b: The game session: Creating questions

The main goal of the game is to create difficult - but answerable questions - so that the opposing team will not be able to gain points. When joining the game the teams are assigned a colour (*Team Red* and *Team Blue* in our example). When a player from *Team Red* approaches the first item and points the device - so that the paper marker placed by the educator is visible on the device - the MAR application shows the additional information about the item. This action also makes the *Create Question* button active. Now each team has then to create a question, associated to a particular item, and provide three possible answers, only one of which is correct. The system creates no restrictions about information gathering. In order to create the questions the

players could for example browse the internet to find interesting facts linked to the items. If the teacher considers it more useful, the players can be “forced” to explore the museum exhibits and gain some new knowledge about its artefacts. And so on. This kind of game dynamic require also for good cooperation within the team.

Phase 2-c: The game session: Answering questions

When both teams have finished the questions creation, the answering phase starts (Fig. 4). All the items that were inserted in the game by the supervisor have now questions linked to them. The players from *Team Blue* are now in front of the same marker and are reading the question created by the *Team Red*. At the same time the *Team Red* is answering to the questions created by the *Team Blue*. Once all the teams have found all the items and answered all the questions, information on the supervisor screen gets updated (Fig.5). The supervisor is then able to see the list of the questions, the chosen answers for both teams, and their final score. These results can then be used for further briefing.

MagMAR is not conceived for a specific museum. Instead the design focuses on flexibility and on the possibility to deploy and play the game at any location (museums but also workshops, small galleries, and local exhibitions).

The setting up phase allows denoting any physical object the educators want the students to create questions for. The starting information is also provided by the teacher and it does not require any involvement of the museum, though it does not exclude it. Finally, associating information to the physical object with small markers and accessing it through augmented reality requires minimal impact on the physical area of the museum.

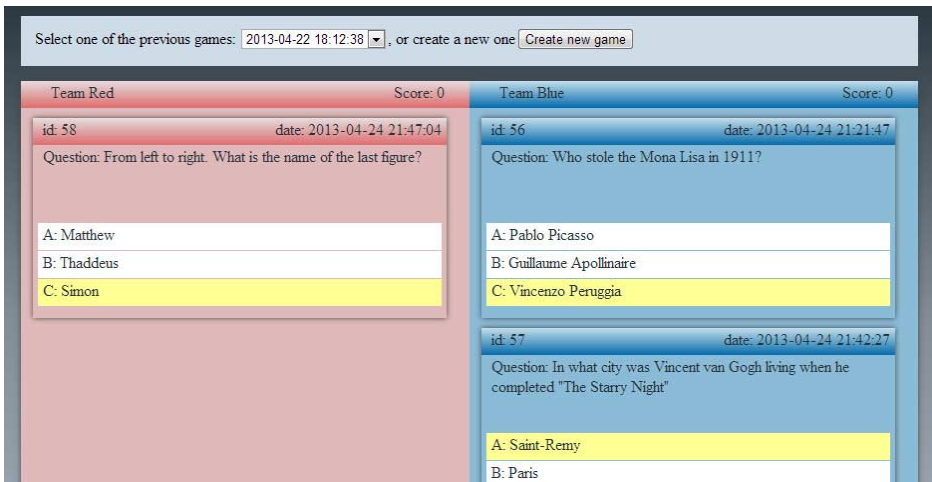

Figure 5. Game monitoring

Phase 3: Reflection after the game

In the current prototype this phase is not explicitly supported, for example through a specific web interface. However at the end of the game the educator can still see the questions created and the results of the teams. The educator can thus use them to (i)

discuss with the students about the game session; (ii) use them to identify e.g., knowledge gaps, interesting points for further discussion, and so on.

6. Testing MagMAR in a museum: initial results and future works

An initial experimentation of MagMAR was conducted with 9 students (average age 18) from a high school class and their young, but experienced teacher. The experimentation was held in a contemporary art museum in Milan, Italy. We asked the students and the teacher to use MagMAR for a part of the museum visit, while using a classical guided visit for the rest of the time. Before the visit the teacher inserted in the system information on 11 artistic artefacts she planned to focus on during the visit. Due to time constraints and some technical problems with the prototype, students were asked to create questions only for the first two items, and the global visiting experience involved only 5 artistic artefacts. For the first item, the students created the questions while sitting on the floor in a room nearby the one where the painting of interest was located. For the second item, the students created and answered their questions while standing in the room where the painting was located, together with other works from the same period. While playing the game, the students were given not only a mobile phone with the MagMAR game, but also a museum guide, an Ipad with Internet connection, and they could use the content already displayed in the museum or ask the teacher in order to create and answer the questions.

Hereafter we briefly describe our findings summarizing the results from the observation held during the experimentation and the results of a survey we conducted after the visit. The survey was constructed around a set of quantitative questions - asking to rate from 1 to 5 some affirmations (1= strongly disagree; 5=strongly agree) - and other more qualitative questions to let the students and the teacher free to express more complex statements.

The evaluation of the game was very positive. Not only the students declared they had fun (4.2 average rate) but we observed they were strongly engaged during the game, discussing about the best strategy to use in creating the questions in order to win. Sociability was also important during the game. Students reported that collaborating with the others helped them to learn more about the museum items (average 4.1), even if collaborating was more fun (4.9) than helpful (3.8). Challenging the others was considered the factor that made the game experience more compelling (4.8). The game also worked as stimulus for information retrieval as the students used all the instruments at their disposal to create complicated questions. It is interesting to note that while for the first item they remained seated and only consulted the provided book and the Internet, for the second item they walked around trying to find content for possible answers also in the information exposed in the exhibit (in the specific case, the name of painters contemporary to the one of the focal painting). Though this is clearly not sufficient to draw any general conclusion, it was still interesting to see how the game could actually motivate an exploration of the museum and how a relatively small change of the playing conditions might have impacted on the type of questions that were formulated. Creating and answering questions was considered to help in learning something more about the museum items (3.9 and 4.2 respectively). In addition when asked what they remembered from the museum visit, the students answered with the content of the questions they created. From the observations we can add that one of the groups used the teacher as shortcut to answer the questions. As students were proud of

the questions they created (4.4) this could be an indicator that creating the questions was funnier than answering them. However this is a topic that needs to be investigated further.

On the overall, being involved in first person in the creation of the questions made the experience more interesting. For example, one of the students wrote that “*During the game I was much more interested in the paintings as I was directly involved in the researches about the paintings.*” Another one added that “*During the game, being involved in first person in the painting explanation,... I enjoyed it very much and I learned things that I still have in mind*”.

Another interesting point is linked to the museum exploration. From the teacher and observers point of view the game distracted the students from the interaction with the museum as their focus was directed towards the game and not the surroundings (the paintings). The situation seemed to reverse while doing the guided tour with the teacher. However students stated that the game encouraged them to explore the museum in a new way (4.6) while some of them (3) reported that they got somehow distracted after the game session. However, though the game on the overall was not perceived as a distraction, the use of augmented reality was more problematic. The current game is not able to exploit the full potential of augmented reality, it distracted the students and as a matter of fact none of them read the content previously inserted by the teacher.

In addition both the teacher and the students stated that a previous explanation of the paintings could have improved the experience.

Finally, a separate discussion should be done about the monitoring phase. The teacher gave the maximum rate (5) to the possibility to monitor the students while playing the game. This leads to think about the importance of this monitoring phase which should be further investigated. Given the positive results from the initial evaluation and because of the flexibility of the application (i.e., its possibility to be applied in different settings), during the next school year we will involve other classes in a more extensive trial.

Acknowledgements

The work is co-funded by NFR-VERDIKT 176841/SIO FABULA (<http://teseolab.org>). The authors want to thank the teachers and the students of the “Scuola della Comunità Ebraica di Milano” and the “Museo del ‘900” in Milan, Italy for their availability and kindness.

References

- [1]Hobsbawm, E. J. (1994). Age of extremes : the short twentieth century, 1914-1991. Michael Joseph ; Viking Penguin.
- [2]European Commission- ACCESS OF YOUNG PEOPLE TO CULTURE Final Report EACEA/2008/01 (OJ 2008/S 91-122802)
- [3]The Lifelong Learning Programme. Report: I GIOVANI E I MUSEI D'ARTE CONTEMPORANEA
- [4]IL MUSEO INVISIBILE. P.L. Sacco and M. Trimarchi. Sistema Impresa e Cultura-<http://www.regione.toscana.it/documents/10180/70936/Museo%20invisibile/>
- [5]Prensky, M. Don't bother me mom, I'm learning! Paragon House Publishers. 2006. www.marcprensky.com/writing/Prensky%20-%20Ch1-Digital%20Game-Based%20Learning.pdf
- [6]Szymanski, M., Aoki, P., Grinter, R., Hurst, A., Thornton, J., & Woodruff, A. (2008). Sotto Voce: Facilitating social learning in a historic house. *Computer Supported Cooperative Work*, 17, 5–34.

- [7]Hall, T., & Bannon, L. (2006). Designing ubiquitous computing to enhance children's learning in museums. *Journal of Computer Assisted Learning*, 22(4), 231–243.
- [8]Damala, A., Cubaud, P., Bationo, A., Houlier, P., & Marchal, I. (2008). Bridging the gap between the digital and the physical: Design and evaluation of a mobile augmented reality guide for the museum visit. In 3rd ACM International Conference on Digital and Interactive Media in Entertainment and Arts, (pp. 120–128). New York: ACM Press.
- [9]Fondazione Fitzcarraldo e osservatorio culturale Piemonte: DON'T GO TO MUSEUMS! Non-visitors: teenagers at a glance. Retrieved June 2013 at: http://www.fitzcarraldo.it/en/research/idontgotouseums_abstract.pdf
- [10]Costabile, M. F., Fogli, D., Mussio, P. and Piccinno, A. (2007). Visual Interactive Systems for End- User Development: A Model-Based Design Methodology. *IEEE Transactions on Systems, Man, and Cybernetics - Part A: Systems and Humans*, 37, 6 (2007), 1029-1046.
- [11]Costabile, M. F., Fogli, D., Fresta, G., Mussio, P. and Piccinno, A. (2003). Building environments for End-User Development and Tailoring. In *Proceedings of the IEEE Symposium on Human Centric Computing Languages and Environments (Auckland, New Zealand, 2003). HCC'03*. IEEE Computer Society, 31-38.
- [12]Lieberman, H., Paternò, F. and Wulf, V. (2006). *End User Development*. Springer.
- [13]Kafai, Y. B. (2006). Playing and making games for learning. *Games and Culture*, 1(1), 36.
- [14]Kafai, Y., Franke, M., Ching, C., & Shih, J. (1998). Game design as an interactive learning environment for fostering students' and teachers' mathematical inquiry. *International Journal of Computers for Mathematical Learning*, 3(2), 149–184.
- [15]European Commission /EACEA/ Eurydice, 2012. *Developing Key Competences at School in Europe: Challenges and Opportunities for Policy*. Eurydice Report. Luxembourg: Publications Office of the European Union.
- [16] “La periodizzazione tra acquisizione dei saperi e didattica per competenze. L'insegnamento della storia dell'arte nella scuola, verso Europa 2020”. Irene Baldriga, Intervento al CUNSTA, Consulta Universitaria Nazionale per la Storia dell'Arte, 2012.
- [17] N. Yiannoutsou, N. Avouris, (2012). From information consuming to participating: game-design supporting learning experiences in museums, *Proceedings of the 8th Pan-Hellenic Conference with International Participation «ICT in Education»*, Volos, Greece, 28-30 September 2012, available online: <http://hcicte2012.uth.gr>
- [18]Daniel Wagner and Dieter Schmalstieg. First steps towards handheld augmented reality. In *Proceedings of the 7th IEEE International Symposium on Wearable Computers, ISWC '03*, pages 127–134, Washington, DC, USA, 2003. IEEE Computer Society.
- [19]Isabelle Damala, Areti; Marchal and Pascal Houlier. Merging augmented reality based features in mobile multimedia museum guides. *XXI International CIPA Symposium*, 2006.
- [20]Susan A. Yoon & Karen Elinich & Joyce Wang & Christopher Steinmeier & Sean Tucker. Using augmented reality and knowledge-building scaffolds to improve learning in a science museum. *Springer. International Journal of Computer-Supported Collaborative Learning*. Volume 7, Issue 4, pp 519-541
- [21]Papadimitriou I. Komis V. Yiannoutsou, N. and N. Avouris. “Playing with” museum exhibits: designing educational games mediated by mobile technology, *Proc. Of IDC 2009, 8th International conference on interaction design and children*. June 3-5, 2009, Como, Italy, pp.230-233. ACM Press, New York, NY.
- [22]Michael Zyda. From visual simulation to virtual reality to games. *Computer*, 38(9):2532, September 2005.
- [23]Beale, K. (Ed.). (2011). *Museums at play: Games interaction and learning*. Museums Etc
- [24]Su Young Kwak. Designing a handheld interactive scavenger hunt game to enhance museum experience. M.Sc., 2004.
- [25]The MARQ project: <http://handheldar.icg.tugraz.at/marq.php>
- [26]Dan Ariely (2010) *The upside of irrationality: the unexpected benefits of defying logic at work and at home*, HarperCollins.

Beyond Artificial Intelligence Markup Language (AIML) Rapid prototyping of a Q&A system

Ioannis DOUMANIS¹ and Serengul SMITH

Middlesex University, The Burroughs Hendon, London NW4 4BT

Abstract. Although Q&A systems have attracted a lot of research interest and efforts during the past few years (e.g. [1] and [2]), there are still a limited number of freely available tools for rapid application prototyping. This paper reviews and compares the available resources and suggests the Virtual People Factory (VPF) [3] as a good solution to rapidly built such systems. It then suggests a novel natural language processing (NLP) algorithm, as an additional layer to increase the VPF accuracy. Finally, the paper discusses a short study where the two approaches (script-based vs. language parsing) are compared and draws conclusions on their performance.

Keywords. Natural language processing, question-answering systems, cultural heritage

Introduction

Preparing a Question & Answering (Q&A) system to accept free-form questions is a difficult and time-consuming process. As an example, we created a Q&A system in the domain of cultural heritage that accepts natural language questions about a medieval castle in Greece. The system was created to be capable of free-form Q&A about a limited number of locations in the castle with users in a lab environment [4]. The system's development took approximately 3 weeks and 100 hours of work to develop a conversational model with 59% accuracy. In this paper, we present the review we performed on a number of suitable tools for the development of the prototype. We selected these tools based on two requirements: a) free availability and b) rapid application development. Then, based on our comparison we conclude with Virtual People Factory (VPF)[3] as the tool to be used in the development of the prototype. The Virtual People Factory (VPF) is a freely available web application that offers an easy-to-use interface for the rapid development of Q&A systems.

Developers with minimal programming skills can create a conversational model online and integrate it with any desktop or web application with ease. However, as the VPF does not process language its limitations become apparent fairly quickly. Because the system does not recognize parts of speech (POS) for instance, it fails to distinguish keywords serving different syntactical functions in different user input. Further, the

¹ Corresponding Author: *Middlesex University, The Burroughs Hendon, London NW4 4BT*; Email: ioannis.doumanis@lsst.ac

absence of a dialogue manager makes it difficult to keep the topic of a conversation for several dialogue turns. To address these limitations we designed a natural language processing algorithm and a dialogue manager. We fully implemented the algorithm but not the dialogue manager. The algorithm adds three additional processing layers to the VPF web service. We detail our NLP approach and the benefits it adds to VPF. Finally, we present a short study where we compare our algorithm with the VPF service and draw conclusions on their performances.

1. PandoraBots

PandoraBots [5] is a free-to-use Artificial Intelligence (AI) web application used mainly to develop and publish software robots (or chatbots) on the World Wide Web. It has a large user community with more than 200,000 chatbots in multiple languages. Pandorabots is considered the representative of contemporary chatbot language processing. The service has been recently used in mobile applications to allow users to manage information through natural language commands. A very good example, is Jannie [6], a mobile virtual assistant that can answer natural language questions, send emails, play music automatically and much more.

The conversational engine of Pandorabots is based on AIML (Artificial Intelligence Modelling Language), an XML-based language created by Dr Richard Wallace [7] for creating conversational systems. The fundamental unit of knowledge in AIML is a pattern-template pair (see Figure 1), where patterns match the user's input and templates produce a response to the user's input matching the corresponding patterns. Pandorobot developers have the option to load a knowledgebase of 40,000 patterns in any newly created conversational system. However, any additional piece of knowledge needs to be written in AIML using an online editor. Further, AIML is not designed to process language and to understand the meaning and structure of words and sentences.

```

<category>
  <pattern>WHAT ARE YOU</pattern>
  <template>
    <think><set name="topic">Me</set></think>
    I am your intelligent tour guide of the Monemvasia castle
  </template>
</category>

```

Figure 1. Example of an AIML category

2. The Personality Forge Engine

The Personality Forge Engine [8] is another yet more sophisticated free-to-use chatbot hosting service. It follows the same pattern-based approach as Pandorabox where the user's input is matched against predefined pairs of patterns in the database. However, as opposed to Pandorabox developers enter knowledge in the system in plain English using a simple web form. A custom-made scripting language is also available (called AIsript) for advanced developers to further extend the conversational capabilities of

the chatbots. In the sample code shown in Figure 2, developers can store the food the user likes in the bot's memory. Further, the system processes the user's input for its correct syntax before determining the best response. According to the official web site, the Personality Forge's AI Engine has a build in knowledge of over 150,000 words.

This remembers (key1) in the memory "foodyoulike"

Keyphrase	Rank	Emotion	AI Script	
I like to eat (np)	0	0	<?PF remember (key1) as "foodyoulike"; ?	
			Response	1
			How could you not like (key1)?	<input type="checkbox"/>
			Have you had any recently?	<input type="checkbox"/>

Figure 2. An AIScript example

3. The Virtual People Factory(VPF)

The Virtual People Factory [3] is a web application designed to educate Pharmacy/Medical students in effective patient-doctor communication skills. The system allows the development of conversational models that simulate various medical scenarios (e.g., a complete neurological examination on a virtual patient). The usefulness of VPF is not limited to medical scenarios. It can be used to simulate any scenario where dialogue is needed. Similar to the other two systems, VPF follows a pattern-based approach to match the user's input to the database. However, it differs from Pandorabox and Personality Forge in a number of ways:

1. Both Personality Forge and PandoraBots require rules to be said verbatim to match the input string. On the other hand, VPF uses a matching heuristic to determine the similarity of the input (OK, I am ready lets begin the tour) to an entry in the script (lets begin the tour).
2. Because of the above approach in input matching, VPF requires fewer rules to answer the same output in comparison to both Personality Forge and PandoraBots. This has a significant impact on the systems performance and management of scripts for large application domains.
3. VPF, in contrast to Personality Forge and PandoraBots, enables a developer to define how-well a rule should match the input and cut-off any matched-rules below that threshold level.
4. Creating a good script in PandoraBots and Personality Forge requires extensive knowledge of each engines internal scripting language. VPF scripts, on the other hand, are written in plain English.
5. VPF considers the information space in terms of acts (very large chunks of information) and topics (smaller chunks of information). PandoraBots divides the information space only into topics. Personality Forge does not create subsets of input data as topics of conversation readily.
6. VPF provides an easy-to-use system to deal with the systems failed responses. The absence of a similar system is perhaps the biggest weakness of Personality Forge as it makes correcting failed output from the system a very difficult task.

7. VPF endows developers with full control over a response of the system. However in Personality Forge, the AI engine takes control of the systems output with random responses quite often being produced.
8. The VPF in contrast to Personality Forge offers a reliable web environment for development and testing of Virtual Humans. The low data transfer speeds of Personality Forge limit the usefulness of that service.
9. Contrary to Personality Forge, VPF offers a free and easy-to-use API (Application Programmable Interface) for integration into applications. There is no limitation on the number of messages a program can exchange with the VPF server. On the other hand, the free version of "Personality Forge" API is limited to 500 responses [9].
10. Although Personality Forge use world list wildcard rules, these are not associated with a single word and therefore are not automatically reusable throughout a script. VPF offers a simple but very intuitive Synonym-List finder that automatically associates the chosen keywords with synonym lists for the entire script.

Based on this discussion, it is clear that VPF is the tool of choice for our development needs. However, as discussed in the next section there is room for additional improvements to increase its accuracy.

4. NLP Algorithm

The workflow of the current implementation of the algorithm can be seen in Figure 3. It uses a four-layered approach to map an input string from the user to an appropriate response in the database. At the first-layer of processing is Virtual People Factory [3]. The designer defines the knowledge contained in a domain by entering (in plain English) pairs of questions & answers in the VPFs database. It provides the first processing layer for the input by computing its similarity to a question (called a trigger) in the database. Once the trigger is found, the system responds with the answer (called a speech) for the trigger [2]. A major step in the matching process is the use of a list of global keywords. These are the most important words used by triggers globally and are extracted in real-time when the designer enters the question & answer pairs in the database. However, as the keywords are not annotated with part of speech (POS) information, VPF fails to distinguish ambiguities between triggers that contain the same global keywords. For example, consider the following two triggers: a) shall we begin the tour? b) Can we tour now?

The third layer performs a deep syntactic analysis on the input string. It parses the input for predicates and deep syntax dependences using the Sanford Parser [12] and Antelope API [10]. It then searches for the best match of the parsed input against phrases in the database. The matching process involves several comparisons/matching tests with incrementally relaxed conditions. This ensures that if at least some of the predicate arguments of the input and the database are the same (or similar), matching will be successful. Once a match is found, the phrase is passed to the VPF for an exact match. If this step fails, the system either does not have a response, or it did not understand the question the way the user asked it. Hence, it replies with a generic off-topic response (e.g., I do not understand please rephrase or move to a different topic).

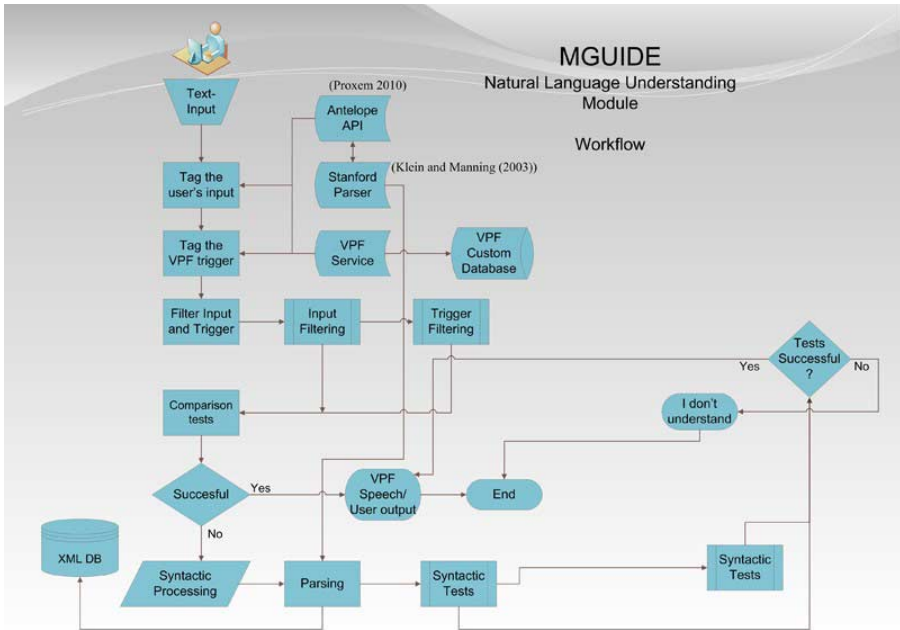

Figure 3. The workflow of the algorithm

We have also designed and partially implemented a fifth processing layer that was not included in the current algorithm implementation. It performs shallow semantic analysis of the input text. A shallow form of semantic representation is a case-form analysis, which identifies the sentences predicate (e.g., a verb) and its thematic roles (e.g., AGENT, EXPERIENCER, etc.). In a few words, this process assigns who did what to whom, when, where, why, and how to the input sentence. Currently, the modules semantic component is not mature enough to be used in a real dialogue application. It uses an open-source semantic parser [10] which is highly experimental. However, even if the parser is improved in future versions, it is unlikely that it will become powerful enough to resolve accurately the natural language ambiguities even in limited domains. Consider for instance, the utterance I want more information about the church. The subject I can be considered either as an AGENT (i.e., who performs the action) or the EXPERIENCER (who receives the result of the action) of the predicate, so there are two distinct case-frames. An experimental semantic processing stage in the current algorithm (discussed above) has been developed to address this problem (within limits). In particular, it uses a predefined library of valid case-frames in the domain of the prototypes (e.g., frame want, frame see, etc.) in order to automatically cut any invalid interpretations. With this constraint, it then searches for specific thematic roles (and their values) to help make sense what is being discussed. For example, the previous sentence maps to frame want with thematic roles and values: PATIENT: Information, GOAL: Church. Once the same case name and a case component with the same label and value match, the utterance for that frame is returned. Of course, more research and development is needed to refine this stage, but it can currently match correctly a range of questions (and paraphrases) to the corresponding frames in the sample database. The code for this stage will be released as open source, along with the rest of the algorithm.

5. Dialogue Manager

The dialogue manager is modelled as a Hierarchical Tasks Decomposition process: acts, topics, subtopics, and their associative trigger templates. Trigger templates are framed-like structures with slots representing a trigger phrases case frame, predicate argument structures and POS keywords. For each trigger phrase in the database, a separate template is defined.

This process is being carried out semi-automatically, where the system generates the templates automatically and the designer manually corrects any failed or multiple interpretations of the trigger phrase. This hierarchy allows the system to keep the context as it has detailed information on what has been activated at each level of the conversation (e.g. POS keyword(s)). Figure 4, shows a generated graph for the domain of the prototypes (i.e., a tour of a medieval castle) along with two trigger templates for the phrase “I want more information about the central gate”.

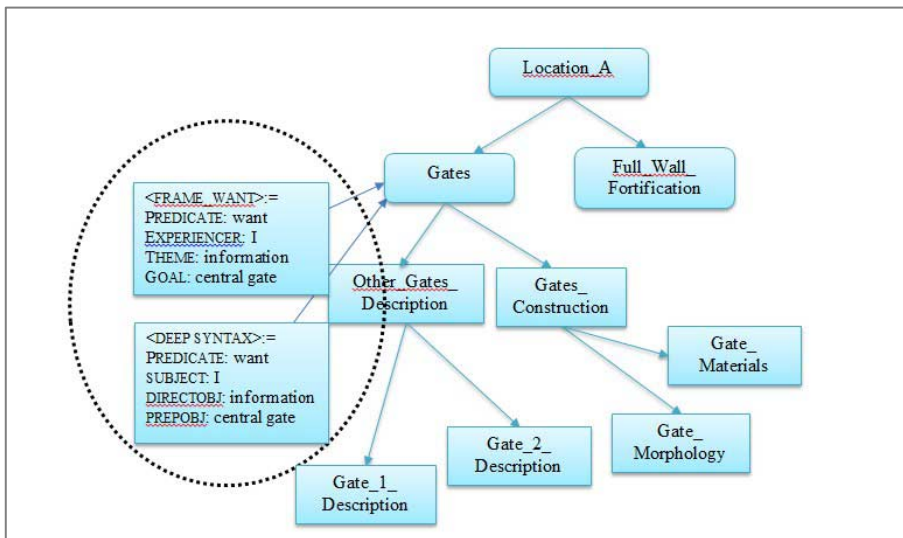

Figure 4. A sample graph generated by the dialogue manager

Each of the above nodes carries an activation list, where the developer specifies:

1. How many times a node should be activated. For example, the Introduction nodes are activated only once. This way, the ECA can understand when the greeting time is over and the real conversation begins.
2. Prioritize the activation of the nodes using a priority value. For example in the graph of Figure 4, the node Gate Morphology logically has a greater probability to be next in the discussion than the Gate Materials. This is because a user will most likely ask questions about the form of the gate first, before getting into questions about the materials that were used in its construction. This prioritization value for each node is difficult to determine, and should be empirically determined through testing.

3. Define each node activation preconditions. For example, the Gates Construction node can only be activated if the node Gates has been activated first.
4. How the system responds when the above conditions are not met. For example if the greeting time is over and the user says hello, a reply could be “Ioannis, how many times are you going to say hello to me”.

6. Algorithmic performance

The current implementation of the algorithm has two layers (a shallow parsing and deep syntactic processing layer), to map the users input to a proper response in the database. Although parsing is more precise than the script-based approach, it needs much processing power. As it is not always possible for mobile devices to have a stable Internet connection for processing to take place in the cloud, some of the processing should be conducted locally. For this reason, we sought to compare scripts with shallow parsing (scripts vs. shallow parsing) to get some insights into the robustness of each method. Furthermore, we compared each of these methods with the deep syntactic processing approach in order to investigate further what is lost when precision is sacrificed for robustness. We had the following hypothesis:

H1: The deep syntactic processing approach does not overall outperforms a script-based approach, but it is better for processing more complex questions.

H2: There is no overall performance difference between the script and the shallow parsing approach. However, an overall performance difference between the shallow parsing, and the deep syntactic processing approach is expected.

Using the end-user logs from a pilot experiment we conducted using the prototype Q&A system [4], we extracted 60 questions which the systems failed to answer and asked an expert to create their responses. These new sets of stimuli-responses were used to augment the existing corpus using the VPF tool. There is evidence in literature [11] that the use of both end-users and domain-specific experts in the process of conversational modelling provides a more comprehensive coverage of the conversational space than when the model is crafted by a developer alone. Therefore, the conversational corpus used by both systems should be sufficient enough to enable a more effective comparison of the methods used for processing natural language questions. The following methods were investigated:

- Scripts vs. shallow parsing
- Scripts vs. deep syntactic processing
- Shallow parsing vs. deep syntactic processing

In all conditions, a single user asked each system 60 random questions that covered the four locations in the castle for which the system was providing information and marked each system response using the following scale:

- Each correct answer received 20 points
- Each relevant answer 10 points

- Each irrelevant answer 5 points
- No points were given when the system returned a random answer (or no answer at all).

The total score (expressed as the percentage of the points given for achieving a perfect score) achieved gave the overall performance of each method. Table 1 shows the results:

Table 1. Algorithmic performance between the conditions

Comparison	Performance	
Scripts vs. shallow parsing	59%	57%
Scripts vs. deep syntactic processing	59%	57%
Shallow parsing vs. deep syntactic processing	57%	40%

There was a variation of performance for the deep syntactic processing method, across the content presented about the locations of the two routes (40% vs. 25%) (see Table 1 and Table 2). This effect was not observed in any other condition. This is clearly due to the unknown predicates used in the questions asked in the attractions of the second route. The predicate matching heuristic of the deep syntactic processing layer fails if the database does not contain the relevant predicates.

Table 2. Algorithmic comparisons per type and part of the tour

	Script Approach	Shallow Parsing	Deep Syntactic Processing
First part of the Tour	58%	56%	40%
Second part of the Tour	59%	57%	25%

In terms of overall performance, the results validate my original hypotheses (see H1 and H2). Although scripts questions with poor language skills, they are clearly more robust in providing overall better answers than the parsing approaches (i.e., both shallow parsing and deep syntactic processing). The slight difference in performance between scripts and the shallow parsing approach shows that the method can be used for filtering-out input-stimuli pairs that do not match grammatically and, therefore, provide more accurate answers. Furthermore, the results show that the deep syntactic processing layer performed below average. As the syntactic parser [10] is still not mature enough, it gave several failed parses of questions that dropped the overall performance of this layer. Therefore, it is reasonable to assume that once the performance of the parser is improved in future versions, the performance of this layer will be improved as well.

7. The Q&A System

We used the parsing algorithm to implement a simplistic Q&A system. The system provided participants with cultural content covering popular attractions on two routes in a real archaeological attraction and allowed them to ask questions using plain English after each presentation was complete. Each route included three locations to visit in turn. An expert human-guide wrote the presentations and crafted the initial conversation corpus using the Virtual People Factory authoring tool.

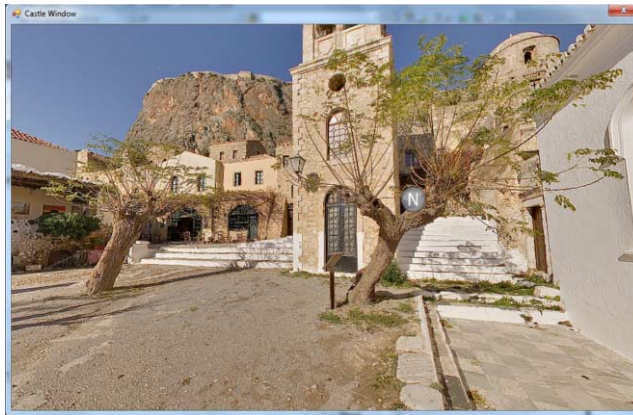
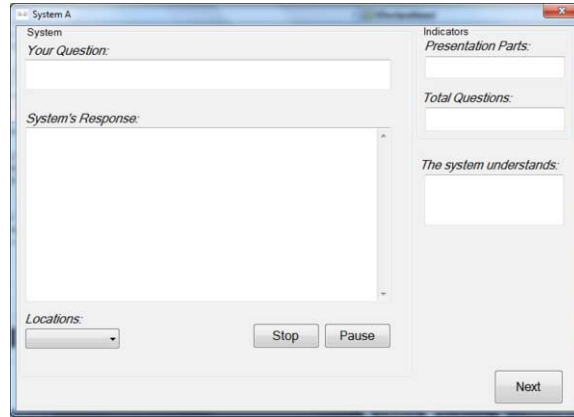

Figure 5. The prototype Q&A system

The interface of the system is simple enough to use without any previous training and it is divided into the following sections:

- The system section:** This section features an input field for typing a question, an output field for displaying the system's response, a drop-down menu for defining the location the user is visiting, and two buttons for controlling the speech output of the system.

- **The indicators section:** This section provides information about the total number of questions asked, the database question the system matched the input question to, and the part of the presentation where the user is currently listening.

A simple key combination activates the display of an interactive panoramic representation of each location participants had to visit. The system was compared with a similar system featuring only the script-based algorithm in an empirical study in the lab. The results of this experiment are discussed in [4].

8. Conclusion and Future Work

This paper presented a more robust and linguistically motivated different option for the development of Q&A systems to the open-source tools currently available to the ECA research community. Developing and releasing the full algorithm and dialogue manager is a long-term goal. However, the current implementation of the algorithm will be released as open-source immediately for the benefits of the virtual human research community. Our current work involves developing an editor and a simple API, to allow developers to integrate with ease, Question & Answering (Q&A) functionality to their applications. The editor allows the designer to map sample questions-to-answers in a simple and straightforward way. It updates its internal databases automatically, while the user enters the question-answer pairs in the editor. The lexical information (e.g., predicate synonyms) required by the algorithm, are provided by the designer in the settings panel of the editor. Other more advanced features, like the threshold applied in each script, are accessible via the web interface of the VPF system. The API is compatible with all the recent windows operating systems (OS); integrated development environments (IDEs), which we hope will encourage the wider dissemination of the algorithm in developing systems. We welcome collaborations on the further development of the editor and the algorithm.

References

- [1] Leuski, A., et al.: Building effective question answering characters. In: Proceedings of the 7th SIGdial Workshop on Discourse and Dialogue (2006).
- [2] Dickerson, R., Johnsen, K., Raji, A., Lok, B., Hernandez, J., Stevens, A., and D. Lind. (2005): "Evaluating a Script-Based Approach to Simulating Patient-Doctor Interaction" SCS 2005, International Conference on Human-Computer Interface Advances for Modeling and Simulating (SIMCHI 05), 23-27 January 2005, New Orleans, pp.79-84.
- [3] Virtual People Factory (VPF) (2012) (Available from: <http://www.virtualpeoplefactory.com/VirtualPeopleFactory/>) [Accessed December 31 2012].
- [4] Doumanis, I. (2013): "Evaluating Humanoid Embodied Conversational Agents in Mobile Guide Applications". Thesis (PhD). Middlesex University
- [5] PandoraBots (2012) (Available from: <http://www.pandorabots.com/botmaster/en/home>) [Accessed December 31 2012].
- [6] Pannous GmbH, Jeannie, Android Mobile Application and manual, Hasloh, Germany, Europe.
- [7] Wallace, R. (2003). The Elements of AIML Style. [Online]. Available from: <http://www.alicebot.org/style.pdf>. [Accessed: 6/5/2010].
- [8] Personality Forge (2012) (Available from: <http://www.personalityforge.com/>) [Accessed December 31 2012].

- [9] Personality Forge Chatbot API (2012) (Available from: <http://www.personalityforge.com/chatbotapi.php>) [Accessed December 31 2012].
- [10] Proxem Advanced Natural Language Object oriented Processing Environment., version 0.8.7 computer program and manual, Proxem, France.
- [11] Rossen, B., Lind, S., Lok, B. (2009): Human-Centered Distributed Conversational Modeling: Efficient Modeling of Robust Virtual Human Conversations. In: Ruttkey, Z., Kipp, M., Nijholt, A., Vilhlmsson, H.H. (eds.) IVA 2009. LNCS, vol. 5773, pp. 474481. Springer, Heidelberg (2009).
- [12] Klein, D. and Manning, C.D. (2003): Accurate unlexilised parsing. In ACL '03 Proceedings of the 41st Annual Meeting on Association for Computational Linguistics – Volume 1, pp. 423 – 430.

From personalization to adaptivity - Creating immersive visits through interactive digital storytelling at the Acropolis Museum

Laia PUJOL^{a1}, Akrivi KATIFORI^b, Maria VAYANOU^b, Maria ROUSSOU^b, Manos KARVOUNIS^b, Marialena KYRIAKIDI^b, Stamatia ELEFATHERATOU^a, Yannis IOANNIDIS^b

^aThe Acropolis Museum

^bThe University of Athens

Abstract. Storytelling has recently become a popular way to guide museum visitors, replacing traditional exhibit-centric descriptions by story-centric cohesive narrations with references to the exhibits and multimedia content. This work presents the fundamental elements of the CHES project approach, the goal of which is to provide adaptive, personalized, interactive storytelling for museum visits. We shortly present the CHES project and its background, we detail the proposed storytelling and user models, we describe the provided functionality and we outline the main tools and mechanisms employed. Finally, we present the preliminary results of a recent evaluation study that are informing several directions for future work.

Keywords: archaeological museums, digital interactive storytelling, personalization, adaptation.

1. Introduction

The Acropolis Museum displays a number of information-rich exhibits with associated stories to tell. However, these stories are not immediately available to visitors, due primarily to the gallery's design, which emphasizes the original archaeological objects and therefore consciously prefers non pervasive mediators. Yet, the museum's curators also strive to maintain a mode of "respectful" interaction between visitor and exhibits, according to which the gallery should integrate harmoniously different approaches and modalities of communication.

¹Corresponding author: Principal Project Officer, The Acropolis Museum, DionysiouAreopagitou 15, Weiler Building, 11742 Athens, Greece.

This is where CHESSE comes in. CHESSE (Cultural Heritage Experiences through Socio-personal interactions and Storytelling) is a research project funded by the European Commission's 7th Framework Programme. Its aim is to research, implement and evaluate an innovative conceptual and technological framework that will enable both the experiencing of interactive and adaptive stories for visitors of cultural sites, and the authoring of narrative structures by the cultural content experts.

The present paper focuses on how CHESSE is building a seamless intelligent environment where visitors are immersed in stories related to exhibits in the Acropolis Museum's Archaic Gallery. These stories are tailored to their interests and adapt in real time to the changing parameters of the visit. The following sections will present the context of research; the goals of the project; its initial implementation; the results of an evaluation conducted with museum visitors; and the current developments that push the project forward towards full real-time adaptation.

2. Background

Until recently, storytelling had been an implicit aspect of a museum visit expressed through human guides or more recently through audio guides. A review of storytelling in museum contexts may be found in [1]. The adoption of an explicit storytelling approach to exhibition design contributes to make collections more accessible and engaging for different kinds of audiences. It creates a relaxed environment that raises self-confidence [2]; it establishes a universal way of communication; and because it invites the audience to fill in the blanks with their own experiences, it helps to set emotional connections, which are deeper than intellectual understanding [3, 4].

A museum storytelling approach may draw on the rich history of research into interactive storytelling for digital media, including games and films. Museums, however, raise significant new challenges for interactive storytelling research. The nature of visitor-exhibit interaction is such that digital media must gracefully complement the physical artifacts, which remain the primary focus, while at the same time take into account visitor's needs and preferences.

On the other hand, personalization can also be a valuable tool for the organization of the multi-dimensional museum content, as well as for its communication to an heterogeneous audience [5, 6, 7]. An increasing number of museums and cultural institutions around the world are using personalized applications. For example, there are adaptive applications for different target groups [8, 9], or conversely for visitors with similar interests [10]. In addition, a wide range of mobile and space sensitive devices have been recently developed [11, 12, 13, 14, 15, 16]. And evaluations at different stages have also been conducted. For example, in a study comparing different personalization approaches [17], users were very positive towards adaptation: it helped create an immersive environment that improved orientation, localization of objects, and comparison between them while reducing redundant information. In [18] a detailed survey of the field of personalized applications in cultural heritage is available.

Yet, introducing personalization and adaptation in an interactive digital storytelling system remains, to the best of our knowledge, an unresolved issue.

3. The CHESS project

CHESS² proposes to enrich the museum visit through personalized interactive storytelling experiences by personalizing and dynamically adapting information about cultural artifacts to each individual or group of visitors. CHESS targets two kinds of end-users:

1. Visitors: people experiencing CHESS interactive stories. They are invited to join in the available adventures when entering the museum or from home. When on-site, they participate through their mobile phone, receiving information from the system according to the story plot, their position, their personal profile, but also contributing information in response to the system's solicitations.
2. Authors: non computer-experts (e.g., content providers, curators, and museum staff) in charge of creating cultural interactive experiences for visitors. They use the CHESS authoring tool to create narrative structures that use existing digital multimedia content, support several devices and multiple visitor interactions.

To support this approach, a user-centered design philosophy is followed throughout the entire course of the project, both in the design and the evaluation phases. The main tenets include:

1. An iterative process of design – development – evaluation, which begins with a comprehensive analysis of the needs, wants, and limitations of the end-users. For every step of the project, a multi-tiered evaluation methodology has been set, in order to test the validity of the design, either in real world experiments or through the organization of user workshops.
2. A participatory design methodology, implemented with a small group of end-users (both museum curators and representative groups of visitors) who, either as partners in the consortium or through a user group, actively participate in the planning and design of the scenarios from the outset.
3. The development of both a personalized and an adaptive system, which delivers narrative experiences tailored to each visitor.

The CHESS consortium comprises seven organizations from four different countries, which provide all the necessary competencies throughout three complementary categories of partners: industrial, research-oriented and cultural. The different nature of the cultural partners (an archaeological museum and a science centre) provides an interesting test bed for the implementation of interactive digital storytelling in different contexts. Cité de l'Espace is a science centre displaying educational models with a high degree of interaction, and it expects that CHESS provides a coherent link between exhibits. The Acropolis Museum, on the other hand, displays originals aimed at contemplation, with a low degree of interaction, and expects from CHESS an explicit interpretation of objects.

² The CHESS Project, <http://www.chesseexperience.eu>



Figure 1. The Archaic Gallery

At the Acropolis Museum, the CHES project focuses on the Archaic Gallery (figure 1), which is located on the first floor. Here, visitors can wander amongst the architectural and sculptural remains of the period spanning from the 7th century B.C. to the Persian Wars (480/79 BC). The flexibility of its design, as well as the diversity of historical facts and approaches behind the objects, makes the Archaic Gallery the perfect context to develop the CHES project.

4. Implementing adaptive personalized stories in CHES

4.1 Defining profiles

Personas are detailed descriptions of imaginary people constructed out of well-understood, highly specified data about real people[19]. Personas are not actual people but are synthesized directly from observations of real people. As a design tool, personas are a powerful way to communicate behaviors, goals, and needs. In other words, when creating personas for CHES, we are creating a set of representative profiles, or archetypes, for the visitor base (and also for the authors) of each museum.

For the Acropolis Museum we created five visitor personas (Table1):

Table 1. Visitor personas at the AM.

					
Nikos Athanasiou , 10 year-old: “The museum is boring”	Georgia Athanasiou , retired literature professor: “The museum makes me feel young”	Jack Harris , young athlete: “The museum would be much more interesting if the exhibits could tell me their stories”	Natalie Schmidt , IT executive: “The museum is an excellent way to relax between meetings”	Dimitris Georgiadis , teenager: “The museum would be cooler with technology”	Takis Karathanasis middle-aged shop owner: “The museum is really great but sometimes too much for me”

The definition of personas for CHESS is a result of the synthesis of data from both primary sources (museum data collected via questionnaires, interviews with staff, and ethnographic observations) and secondary sources (visitor studies). This data has been pieced together to define a set of 26 demographic and behavioral variables, with values that are used to describe a) each persona's characteristics (demographic data, interests and attitudes); and b) the context of her visit (visiting duration, social interaction style, preferred way to obtain information and to use the system).

Profiling and subsequent personalization for first-time visitors begins with the CHESS Visitor Survey (CVS), a configurable web application performed using a desktop or mobile web client. The goal of the quiz is to identify the user's characteristics, preferences, and visiting styles through a series of single-choice, multiple-choice and ranking questions. The system is generic and can be used to implement any quiz, provided it contains the constructs supported. It allows a variety of presentation formats (e.g., textual, visual, single/multiple column layout, etc.). It also supports a flexible model for mapping the answers to personalization variables, as part of an XML specification, thus reaching an initial user profile. This profile is then employed for providing personalized versions of the Horse story.

4.2 Storytelling

Stories are commonly considered to have a narrative form, containing a set of smaller story pieces which are typically placed into a static order by the author, so as to communicate one or more messages to the end user/audience. Depending on the type of the story (and the author's will), the ordering of the smaller story pieces may be strict, allowing for no other orderings, or flexible, enabling the production of alternative orderings of the same story pieces, which all convey the same message(s).



Figure 2. The Monster Factory Game

The first distinguishing aspect of CHESS with regard to traditional storytelling is that it is interactive. Interactivity within stories is accomplished at the following levels:

- User interface: visitors interact with the provided content through a predefined set of presentation utilities over the digital resources (zoom, play, pause, stop), and over the whole story structure via navigation menus.

- Multimedia productions: stories contain short-games (figure 2), aimed at enhancing content recall, and augmented reality activities, aimed at enhancing the exploration of exhibits.
- Story plot: user actions and attitudes affect the unfolding of the story plot, thus generating personalized, adaptive experiences.

Another distinguishing aspect in CHESS is that the story unfolds within a specific physical environment, which serves as the story setting. Moreover, through the arrangement of the exhibits, each museum direction mentally sketches an abstract plot, which will hopefully be understood and followed by museum visitors. Hence, when designing storytelling experiences for museums it is of great importance to carefully consider the setting, for three reasons: firstly, the story needs to be able to “serve” the exhibits (although it may contain story pieces that are not directly related to specific exhibits); secondly, the exhibition arrangement may provide story patterns; and finally, the location of objects may imply special requirements or constraints over the multimedia productions employed.

To be able to provide personalized versions of the story to different visitors, authors designed alternative story sub-flows in various points of the main story, based on a variety of visitor and contextual parameters and/or events. In this sense they actually defined a story “space” that includes several candidate stories. During the visitor’s experience, the system leverages the visitor profile, context and actions to appropriately traverse the authored story space and provide a story that is tailored to the visitor’s characteristics, attitudes and needs.

4.3. Authoring flexible CHESS stories

To define alternative flows within the story, authors needed to take into account the most important visitor attitudes and characteristics, which significantly differ between visitors, while also affecting their satisfaction with the overall storytelling experience.

The main candidates for personalization identified so far included the script and its script pieces, the staging of the script, and the short multimedia productions of the staged script pieces. All these entities represent fundamental aspects of the visitor’s experience and each one of them are tailored so as to better match the visitor’s attitudes and needs.

Focusing on the script and its contents, different visitors may have different preferences on a variety of features, such as the plot, the subject (society and politics, war, etc.) or even the type of information provided (e.g. mythological or historical). With regard to the plot, different versions are created to match different personas. For instance, the "Horse" storyboard has two plot versions: one aimed at Nikos engaging him in a quest for the horse's relatives and friends, who are stuck in time; and one for Natalie, where the horse acts as a guide.

With regard to the subject, the horse story is built around a specific theme, namely “Animals and monsters”, and covers several, diverse, secondary subjects, such as society, politics, wars, mythology, sports, etc. Probably, the majority of visitors are not interested in all of these subjects, so different parts of the script are omitted for different visitors, under the condition that such a removal does not influence the script

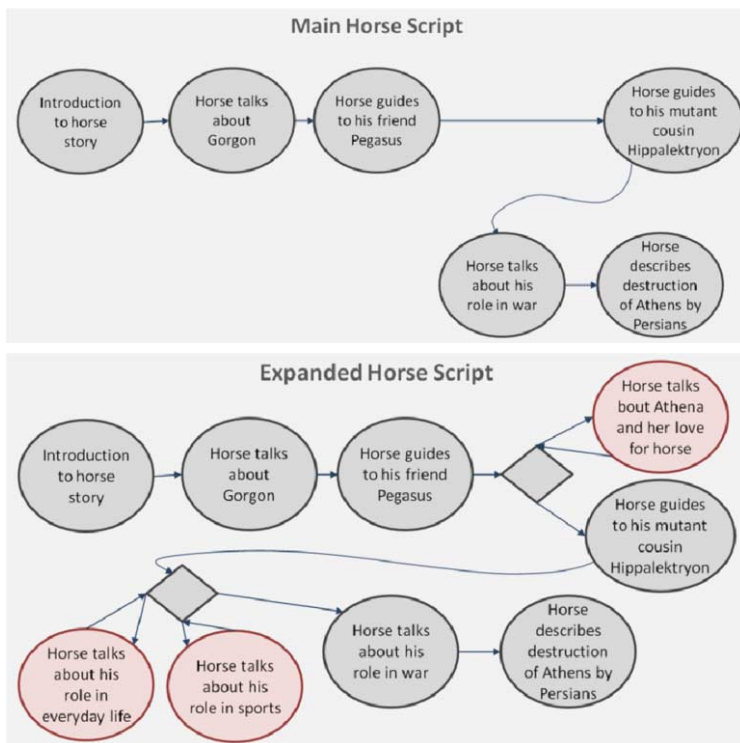

Figure 3. Development of the "Horse" storyboard with optional sub-flows.

plot. This is a very challenging issue, since at first glance there would seem to be some incompatibility between the hypertext structure and the storytelling structure (comprising a beginning, a climax, and a conclusion).

User characteristics and attitudes may also affect the staging of a script. Consider for instance a script piece talking about a mythical creature, for which two exhibits are available in the museum: a statue and a plate in a showcase. In this case the author may choose to define different staging for kids and adults, promoting the exploration of less popular exhibits for adults while considering preservation of enthusiasm as well as visibility issues for kids. Finally, the same holds for multimedia productions, which are designed depending on visitors' particular features and interests.

While a single story was available for the latest evaluation at the Acropolis Museum, new stories are on the way, addressing the needs and expectations of additional personas. When the new stories are entered into the CHESSE system, an additional story selection step will take place at the beginning of the visit, to suggest the story that best matches the visitor's attitudes. Instead of merely using the initial profile on that front, personas profiles will be also leveraged to further address the "cold start" problem. Each visitor will be matched to one (or maybe more) of the aforementioned pre-defined personas and the CHESSE system will promote the stories that are more suitable for the corresponding personas. An overview of the described approach implemented in CHESSE may be found in [20].

4.4 Adaptive storytelling

During the visit, the authored story space is traversed by the CHESSTelling Component to provide an adaptive, personalized storyline. Whenever more than one choices are available in the story space, the CHESSTelling System needs to decide what to do next. Such points in the story space are referred to as decision points and they are indicated with diamonds in fig. 3. So when a decision point is met, the CHESSTelling System uses the visitor profile to estimate the visitor's interest in each one of the candidate story sub-flows.

The initial visitor profile is further refined during the CHESSTelling experience by continuously monitoring user actions and interpreting them to implicit feedback. In particular, two main types of implicit feedback are currently considered. By pressing a "Next" button the visitor can skip to the next piece of the story, thus indicating a high certainty negative feedback for the skipped piece. On the contrary, when a story piece is completed without any visitor intervention, this is considered as low-certainty positive feedback for the specific part. Such positive and negative feedback is encompassed in the visitor's current profile at run-time and interest estimation in decision points is conducted using the updated visitor profile.

Users and storytelling entities are modeled over the same vocabulary of attributes, enabling the use of a wide range of metrics and techniques to compute their similarity [21], which can be either directly employed as a ranking metric for obtaining personalized rankings or leveraged in item-based collaborative filtering algorithms.

Having a set of evaluated alternatives, the Storytelling System has now two options, defining two alternative storytelling strategies. The first is to show all or the most promising (top-k) alternatives to the visitor through menus and let the visitor decide what to do. Menus are computed dynamically for decision points, based on the upcoming sub-flows defined in each case. The second is to automatically select the best ones for the particular user, without letting the visitor know about the other options.

For the purposes of the evaluation study, we have adopted a hybrid strategy with a higher priority to the former. So when a decision point is reached, the appropriate menu is instantiated and presented to the visitor, except for the ones where the author has explicitly disallowed menu display. When the same menu is reached for a second time, the visited branch gets demoted in the menu list of choices.

5. Evaluation

An evaluation of the CHESSTelling system with visitors and museum staff was held at the Acropolis Museum in December 2012. For the needs of the evaluation one story, personalized for two different personas, was produced. From the technical point of view, a full integration of the CHESSTelling system was in place, while the necessary infrastructure so that the mobile devices could seamlessly connect to the CHESSTelling server was installed at the museum.

The issues investigated with regard to personalization were the following: 1) Are the variables considered for personalization significant? 2) Which factors are relevant for adaptation during the visit?

5.1 Method

A group of users was invited to test the CHES prototype experience at the Acropolis Museum on Monday, December 17, 2012. The evaluation took place on a day that the Museum is closed to the general public.

Each visitor was “shadowed” by two members of the CHES team, the observer and the recorder, while moving about the museum, and then interviewed. In particular, the two CHES researchers observed each visitor’s behaviour in the natural context of the activity, one taking notes and the other video recording the experience. After the end of the experience, two semi-structured interviews, one addressing general experience issues and the other focused on personalization issues, took place at the Museum’s temporary exhibitions room. Each individual session lasted approximately one and a half hour.

5.2 Participants

Fifteen visitors completed the evaluation, scheduled in two-hour slots each. Of the fifteen participants, six were male and nine were female. The ages ranged from 10 to 55 (three 10 year olds, one 14 year old, one 20 year old, and ten from 30 to 55 years of age). The recruitment was mainly based on demographic information (such as gender, age or profession). All individuals contacted responded positively to our invitation.

5.3 Procedure

Before the beginning of the observation session, each visitor was introduced to the study and asked to complete the consent form. Then, a small group comprised of the visitor, the researcher-observer, and the recorder holding a video camera, headed towards the museum’s foyer. There the visitor was handed the iPad with the CVS, the short quiz designed to bootstrap personalization.

After completing the CVS (which, on average, took less than 4 minutes), each user was accompanied by his/her observer and recorder to the Archaic Gallery. Then the visitor completed, guided by the Horse, a visit through the Archaic Gallery while listening to the story, exploring the exhibits, and looking at the complementary visual resources on the screen.

5.4 Results

With regard to the first research question, the findings of the evaluation can be organized into three categories, related to the experience, the environment, and the user.

The experience characteristics that determine satisfaction are, amongst others, subject (animals and monsters, etc.), technology (multimedia vs. audio-guide), and size of the experience (long vs. short stories).

1. Subject: our results indicate that two types of participants may be identified: i) those expressing interest on a few, specific subjects, and showing total indifference for the rest; and ii) those expressing interest in almost every subject covered in the horse storyboard. So it seems that in order to effectively address the needs of both types of participants, the storyboard should maintain a focused central theme, which however would be enhanced with a great number of optional subparts covering several diverse secondary subjects.
2. Technology: participants who were not familiar with AR or feel uncomfortable with technology in general would rather not get involved in such a production and they'd prefer more traditional, "audio-guide" alternatives instead. So it seems that in order to encourage visitors to explore all the possibilities offered by the experience, more information about what is next or use instructions should be integrated in seamless transitions from the story path to the different activities.
3. Size of the experience: two extreme types of participants have been observed. On the one hand, some participants kept their experience as short as possible, omitting almost all optional subparts, especially as the story progressed towards the end. They were concerned about the provision of "skipping" functionalities by the storytelling system and their main objective was to avoid getting bored. On the other hand, other participants wanted to join almost every optional subpart and their main objective was to explore the authored space, without missing something important. These participants commented that there were some points during their experience where they would like to ask for additional information on the historical or mythological background or on related exhibits that were close by.

Concerning the environment, our findings indicate that visitors liked to move around in the gallery and did not like staying at the same spot for a long time, especially when they were not required to interact with the system or with the exhibits. It was in fact systematically observed that low-level physical engagement generally hindered visitors' satisfaction, who felt confused about what behavior was expected from them, and looked at the screen expecting a request for interaction or wandered around trying to find an exhibit related to the narration. The seamless integration between the story and the environment through the interactive device and was one of the main drawbacks of the experience. It requires a whole different approach not only from the point of view of the contents, but especially of the communication paradigm, that should better integrate the story and the exhibits through the device.

Concerning the user, we identified three main roles, namely spectator, participant and contributor. A spectator has no personal involvement, (s)he simply follows the production (e.g. traditional audio-visual narrations). A participant is assigned with some task that (s)he needs to accomplish in the current production, as it is usually the case with games, quizzes and AR applications. Finally, a contributor needs to actively participate by providing content (such as text, drawing, photograph, opinion, etc.). We observed that while many participants expressed a high interest in productions

requiring their involvement, some stated that they'd absolutely dislike to be assigned tasks requiring specific actions from their part. Such a dislike is justified with various reasons, such as fear of failing, preference on dramatic tension offered by narratives, general preference on spectator role and so on.

The second research question had to do with the relevant factors for adaptation during the visit. Menus, the main adaptive element at this stage of the project, were in general well received because according to visitors, they allowed having control over their experience and did not interrupt the story flow. On the other hand, and contrary to the usage analysis results in traditional web search environments [22, 23], the order of menu choices did not influence selections.

However, there was a different approach to them depending on the goal of the visit. Some participants had come to learn about the museum's contents. They were interested in many side-stories and preferred to make their own choices through menus (rather than having the system deciding for them) due to their worry of missing out on something interesting. They paid great attention to menu descriptions because they wanted to make well-informed decisions and they wished additional information at some points. On the other hand, some participants had come to have an engaging experience. Consequently, their main concern was not to lose interest during their visit: they were very reluctant to choose side-stories and they did not pay attention to menu descriptions. Moreover, the re-ordering of menu choices confused them.

This indicates that any project integrating technology in a museum setting should take into account the visit's goal as a paramount factor since it influences visitors' attitudes, decisions, behaviours, and appreciation of the whole cultural experience.,

6. Future work

Drawing on the analysis of the large corpus of feedback collected during this evaluation study, and on authors' and visitors' needs, we will continue to formulate our approach. The results will be our starting point for the expansion of the existing stories with additional alternative subparts. We are already investigating the extension of the authored story space with independent pieces (related to close exhibits or to similar themes) that will be dynamically injected upon user request, moving towards emerging storytelling approaches while respecting the story flow as paramount.

With regard to dynamic menus, since the order was deemed irrelevant or even confusing by visitors, the system will now visually highlight the recommended choice. The system will also include a "Hurry" button so that the visitor controls the duration of his/her experience. In this respect, a timeline indicating the path already seen and the remaining story will also be included.

Additionally, user interface issues need to be resolved to protect the fine balance between the visitors' shifting focus from the physical to the digital space. The interface should also ensure that the visitor's movement in space does not break his/her immersion in the experience. In this sense, we are already introducing more multimedia

productions for non-staged script units, proposing more direct or interactive observation of exhibits, enriching the narrator with audio clues, and integrating it all within a new interface of communication.

However, the personalization and adaption system need to take further account of the visiting roles that users may prefer and their relationship with technologies. In this sense, more information about what is next or use instructions should be integrated in seamless transitions from the story path to the different activities. The adaption required for these visitor roles also interacts with the flexibility needed to support the various preferences in content consumption. These user preferences have a considerable impact on the process of authoring new and existing stories.

Therefore, we need to improve the user modeling and profiling basis with more visitor research that helps determine which are the relevant personalization variables. To start with, we will refine the proposed user model with additional demographic and contextual attributes, such as the visit goal, which can be potentially employed to identify and discriminate between different types of visits or visitors, providing important indications about the sets of their attitudes.

7. Conclusions

The main challenge for museums in the 21st century is to provide immersive experiences that make cultural heritage relevant for an heterogeneous audience. Personalized, adaptive storytelling is a very promising solution, which nevertheless entails its own challenges. Mainly, how to engage visitors in a story by maintaining story-coherency and preserving an uninterrupted feeling of a story flow, while also adjusting the story to better match visitor characteristics and needs.

Our main contributions to this field starts with the development of a storytelling model where stories are represented in a modular fashion as graphs, in three different levels of abstraction. Each graph uniformly represents numerous alternative story versions which are instantiated based on visitor and contextual attributes, hence tailoring visitor needs while also preserving story coherency.

We also propose a user model which captures visitor attitudes towards a variety of storytelling aspects. While many research efforts focus on defining fine-grained user models for traditional web or social environments [24, 25, 26], significantly less attention is paid to targeted application areas. Storytelling in museum environments is a new, fascinating research area [27, 28] and we believe that user modeling needs to be further explored under this novel setting.

Finally, we conducted a formative evaluation of the adopted personalization and adaptation approach to investigate the influence of the proposed attitudes to visitors' satisfaction. The preliminary results verify the significance of most of the considered attitudes, while also indicating important dependencies between them.

References

- [1] L. Pujol, M. Roussou, S. Poulou, O. Balet, M. Vayanou, Y. Ioannidis: Personalizing interactive digital storytelling in archaeological museums: the CHESS project. In Proceedings of 40th Annual Conference of Computer Applications and Quantitative Methods in Archaeology (CAA), to appear. Amsterdam University Press, Southampton, UK (2012).
- [2] E. Johnsson: Telling tales. A guide to developing effective storytelling programmes for museums. Renaissance London. C. Adler. London, London Museums Hub, (2006)
- [3] L. Bedford: Storytelling: the real work of museums. *Curator* 44(1): 27-34 (2001).
- [4] J. Springer, S. Kajder, et al.: Digital storytelling at the National Gallery of Art. *Museums & the Web*. D. Bearman and J. Trant. Arlington, VA, Archives & Museums Informatics (2004).
- [5] A. Gaeta, M. Gaeta, P. Ritrovato: A grid based software architecture for delivery of adaptive and personalised learning experiences. *Personal and Ubiquitous Computing*. 13, 207-217 (2007).
- [6] C. H. Muntean, G.-M. Muntean: Open corpus architecture for personalised ubiquitous e-learning. *Personal and Ubiquitous Computing*. 13, 197-205 (2007).
- [7] R. Wakkary, M. Hatala: Situated play in a tangible interface and adaptive audio museum guide. *Personal and Ubiquitous Computing*. 11, 171-191 (2006).
- [8] K. Walczak, R. Wojciechowski, W. Cellary: Dynamic interactive VR network services for education. Proceedings of the ACM symposium on Virtual reality software and technology - VRST '06. pp. 277-286. ACM Press, New York, NY, USA (2006).
- [9] L. Terrenghi, A. Zimmermann: Tailored audio augmented environments for museums. Proceedings of the 9th international conference on Intelligent user interfaces - IUI '04. pp. 334-336. ACM Press, New York, NY, USA (2004).
- [10] Y. Sumi, K. Mase: Supporting the awareness of shared interests and experiences in communities. *International Journal of Human-Computer Studies*. 56, 127-146 (2002).
- [11] T. Hall, L. Bannon: Designing ubiquitous computing to enhance children's interaction in museums. Proceedings of the 2005 conference on Interaction design and children - IDC '05. pp. 62-69. ACM Press, New York, New York, USA (2005).
- [12] G. Jacucci, A. Spagnolli, A. Chalambalakis, A. Morrison, L. Liikkanen, S. Roveda, M. Bertoni: Bodily Explorations in Space: Social Experience of a Multimodal Art Installation. INTERACT '09. Proc. of 12th IFIP TC 13 International Conference on Human-Computer Interaction: Part II. pp. 62-75. Springer-Verlag Berlin Heidelberg (2009).
- [13] G. Leinhardt, K. Crowley, K. Knutson: *Learning Conversations in Museums*. Routledge (2002).
- [14] R. Oppermann, M. Specht: A Context-Sensitive Nomadic Exhibition Guide. *Handheld and Ubiquitous Computing, Lecture Notes in Computer Science*. pp. 127-142 (2000).
- [15] D. Petrelli, A. De Angeli, G. Convertino: A User-Centered Approach to User Modeling. In: Kay, J. (ed.) UM'99 Proceedings of the 7th International conference on User modeling. pp. 255-264. Springer-Verlag New York, Inc., Secaucus, NJ, USA (1999).
- [16] D. Raptis, N. Tselios, N. Avouris: Context-based design of mobile applications for museums. Proceedings of the 7th international conference on Human computer interaction with mobile devices & services - MobileHCI '05. pp. 153-160. ACM Press (2005).
- [17] S. Filippini Fantoni: "Personalization through IT in Museums. Does it really work? The case of the marble museum website". In ICHIM03: Cultural institutions and digital technology. Paris, Ecole du Louvre (2003).
- [18] L. Ardissono, D. Petrelli: UMUI Special Issue on Cultural Heritage Exploration Preface. *User Modeling and User-Adapted Interaction*. 18, 383-387 (2008).
- [19] J. Pruitt, T. Adlin: *The Persona Lifecycle: Keeping People in Mind Throughout Product Design* (p. 744). Morgan Kaufmann Publishers (2006).

- [20] M. Vayanou, M. Karvounis, M.Kyriakidi, A.Katifori, N.Manola, M.Roussou,Y. Ioannidis: Towards Personalized Storytelling for Museum Visits. In Proc. 6th Intl Workshop on Personalized Access, Profile Management, and Context Awareness in Databases - PersDB (2012).
- [21] E. Spertus, M. Sahami, O. Buyukkokten: Evaluating similarity measures: a large-scale study in the orkut social network. Proc. of ACM SIGKDD international conference on Knowledge discovery in data mining (2005).
- [22] T. Joachims, L.Granka, P. Bing, H.Heleneon, G. Geri:Accurately interpreting clickthrough data as implicit feedback. SIGIR,pp. 154-161 (2005)
- [23] T. Joachims, F. Radlinski: Search Engines that Learn from Implicit Feedback. IEEE Computer, Vol. 40, No. 8 (2007)
- [24] B. Steichen, H. Ashman, V. Wade: A comparative survey of Personalised Information Retrieval and Adaptive Hypermedia techniques. Information Processing & Management, Volume 48, Issue 4, 698-724 (2012)
- [25] M. R. Ghorab, D. Zhou, A. O'Connor, V. Wade: Personalised Information Retrieval: survey and classification. User Modeling and User-Adapted Interaction, 1-63, Springer Netherlands (2012).
- [26] S. Yang, B. Long, A.Smola, N. Sadagopan, Z.Zheng, H. Zha: Like like alike: Joint friendship and interest propagation in social networks. In: Proceedings of the 20th International Conference on World Wide Web, pp. 537-546. ACM (2011)
- [27] A. Glassner: Interactive Storytelling: Techniques for 21st Century Fiction. A. K. Peters, ISBN 1568812213 (2004)
- [28] T. Kuflik, O. Stock, M.Zancanaro, A.Gorfinkel, S. Jbara, S. Kats, J.Sheidin, N. Kashtan: A visitor's guide in an active museum: Presentations, communications, and reflection. Journal on Computing and Cultural Heritage (JOCCH), v.3 n.3, p.1-25 (2011)

Keynote: Digital-material hybrid objects and augmented spaces to support the social experience of heritage

Daniela PETRELLI
Art & Design Research Centre
Sheffield Hallam University
Cantor Building, 153 Arundel Street
Sheffield S1 2NU, UK
d.petrelli@shu.ac.uk

Abstract. Digital technology for cultural heritage has been so far designed to favour the delivery of information over the sensorial experience of being there. This approach has had unwelcome consequences such as the dispersion of the social group (of family and/or friends) and a reduced affective response in visitors. I propose the use of smart exhibits and digitally augmented spaces as a way to integrate digital content within the physical context and overcome the issues of social disruption and loss of affective experience. Examples taken from the work currently done within the project MESCH are used to illustrate the potential of this novel approach.

Keywords. Tangible and embedded interaction, smart objects, augmented spaces, social interaction.

“the museum’s preoccupation with the information and the way it is juxtaposed to objects [...] immediately takes the museum visitor one step beyond the material, physical thing they see displayed before them, away from the emotional and other possibilities that may lie in their sensory interaction with it.”
(S. Dudley ‘Museum Materialities’ 2010)

The core problem underlying all forms of digital artefacts is the loss of materiality which is crucial to the appreciation of traditional cultural heritage: how to make digital artefacts tangible in ways that transfer the feeling of materiality, authenticity, or “aura”? The myth that the same sensorial experience can be realized in a digital environment has progressively diminished the value of the physical artefact resulting in the dominance of communication over emotion. But emotion, affect and sensation are essential parts of the experience of heritage, “Yet museums’ preference for the information over the material, and for learning over personal experience more broadly and fundamentally conceived, may risk the production of displays which inhibit and even preclude such affective responses.” [1] The introduction of digital technology in cultural heritage spaces has too often created or increased this gap between the visitors and the heritage instead of bringing the visitors closer to it. I outline what have been, in my opinion, the major issues with the design of digital technology for heritage so far and I suggest to bridge the gap between digital content and material heritage through

the creation of smart exhibits. The development of technology for creating such smart exhibits is the goal of the EU project MESCH, Material EncounterS with digital Cultural Heritage. The examples are under design and development in the project.

Second paragraph.

1. Interaction Beyond the Screen: Smart Objects and Social Spaces

The 'information over object' approach has led to the use of digital technology in cultural heritage ever since computers started to populate the exhibit floor [7]. The intent has been to provide in-depth information and to support different learning styles. Indeed visitors spend more time on site if technology is available [7], but a close observation shows friction between the technology and the heritage context [9]. To start with, the content carefully prepared is rarely looked at in full [7]; Interactive games are often for a single user while others watch over while queuing [3]; Visitors who come together can only rarely enjoy their visit as a group because personalized mobile guides before [8] and augmented reality today [1] are designed to adapt to the individual. The advantage and appreciation of the lone visitor is lost as the group dynamic is disrupted resulting in a lower perceived value of the technology-led tour [4].

The principle of social enjoyment and sharing in the presence of the material collection or historical site is central. Large screens support sharing but they do not move the attention back to the exhibits or the space [9], [10]. Screen-based technology acts as 'attention grabber' capturing the visitors to the point of ignoring the presence of valuable originals and follow the trail ignoring other exhibits they could enjoy more [5].

The MESCH project puts the physical back at the centre of the cultural heritage experience by supporting the creation of networks of adaptive smart exhibits that make physically possible for visitors to "touch the story" [6]. The vision is of a cultural space filled with smart objects, each with their own stories embedded therein, that will be revealed if and when conditions are right, e.g. visitors have reached the right time in the storyline, or a group of them is acting in a certain way, or another smart object is close by. MESCH implements this vision by exploiting and expanding the emerging technologies of Smart Objects enriched with a bespoke application that adapts the content and the behaviour of the object to visitors, their social context and the environment. The physical interactions of the visitors with the smart objects become the key to unlock personalized content: each smart object tracks the interaction and feeds an adaptive engine to produce a tailored behaviour. The gap between the digital and the material collections will be bridged in two directions: the digital content is embedded into the physical object as part of actual physical visits, and the physical experience is used to feed and enrich a further online exploration.

A possible scenario under study in MESCH consists of different objects to be given to different types of visitors at the trenches and forts dug in the Alps during the First World War. These archaeological remains are part of the Italian National Historical Museum of War (Museo Nazionale Storico della Guerra) and are a challenging context as they can evoke tragic events, but very little is left and it is now immersed in a beautiful natural environment. A way to bring it back to life is through sounds, poetry and tailored projections: Young visitors will receive a soldier's tag; Teenagers will receive a sensor-enriched tablet disguised as a captain diary; The elderly will receive a walking stick containing sensors, actuators and loudspeakers. The different devices all monitor the movement of the visitors and deliver content at

different points or in different conditions. When inside the fort the diary triggers a quest for the spots that activate a piece of content; it also reacts to the diary of the enemy hold by a visitor walking by: pairing the diaries of the two captains of the opposite fronts displays the map of the battlefield that is visible only while the two “enemies” collaborate. The walking stick has a movement and sound sensors that control the play of the reading of a soldier’s diary pages when the stick is still and the voice level is low as to not interrupt conversations. The soldiers’ tag needs more people to be unlocked: the members of the group have to walk in line inside the tunnels, as a marching troop, to control the projection on the walls of historical images of the trenches. When the group stops marching the stories of the many how died in the trenches are told.

Acknowledgements

The MESCH team includes: Sheffield Hallam University; University of Limerick; Waag Society; University of Strathclyde; eCTRL; DEN; University of Stuttgart; University Carlos III Madrid; Museo Storico Italiano della Guerra; University of Amsterdam - Allard Pearson Museum; MUSEON; FBK. More information is available at <http://www.mesch-project.eu> ESCH (2013-2017) receives funding from the European Community’s Seventh Framework Programme ‘ICT for access to cultural resources’ (ICT Call 9: FP7-ICT-2011-9) under the Grant Agreement 600851.

References

- [1] Damala, A., Stojanovic, N., Schuchert, T., Moragues, J., Cabrera, A., Gilleade, K. *Adaptive Augmented Reality for Cultural Heritage: ARTiSENSE Project*, Progress in Cultural Heritage Preservation, Springer LNCS 7616, (2012), 746-755.
- [2] Dudley, S. *Museum materialities: Objects, sense and feeling*. In Dudley, S. (ed.) *Museum Materialities: Objects, Engagements, Interpretations*. Routledge, 2010.
- [3] Heath, C., vom Lehn, D., Osborne, J. *Interaction and interactives: collaboration and participation with computer-based exhibits*. *Public Understanding of Science*, 14, (2005) 91-101.
- [4] Lanir, J., Kuflik, T., Dim, E., Wecker, A., Stock, O. *The Influence of a Location-Aware Mobile Guide on Museum Visitors' Behavior, Interacting with Computers*, on-line February 2013.
- [5] Martin, D. *Audio Guides*. *Museum Practice*, 5 (1), (2000), 71-81.
- [6] Petrelli, D., Ciolfi, L., van Dijk, D., Hornecker, E., Not, E., Schmidt, A. *Integrating Material and Digital: A New Way for Cultural Heritage*, *ACM Interactions*, July+August (2013), forthcoming.
- [7] Serrell, B., Raphling, B. *Computers on the exhibit floor*. *Curator*, 35 (3), (1992), 181-189.
- [8] Stock, O., Zancanaro, M., Busetta, P., Callaway, C., Krueger, A., Kruppa, M., Kuflik, T., Not E. and Rocchi, C. *Adaptive, intelligent presentation of information for the museum visitor in PEACH*, In *UMUAI - User Modeling and User-Adapted Interaction*, 17 (3), (2007), 257-304.
- [9] vom Lehn, D. and Heath, C. *Displacing the object: mobile technology and interpretive resources*. *Museum and the Web*, available online http://www.museumsandtheweb.com/biblio/displacing_the_object_mobile_technologies_and_interpr (2003).
- [10] vom Lehn, D., Hindmarsh, J., Luff, P., Heath, C. *Engaging Constable: Revealing art with new technology*. CHI 2007 International Conference on Human Factors in Computing Systems, 1485-1494.

This page intentionally left blank

1st International Workshop on Intelligent Environment (f)or Creative Learning (IECL'13)

Elena Antonopoulou (National Technical University of Athens, Greece)

Athina Papadopoulou (Massachusetts Institute of Technology, USA)

Theodora Vardouli (Massachusetts Institute of Technology, USA)

Eirini Vouliouri (National Technical University of Athens, Greece)

This page intentionally left blank

Introduction to the proceedings of IECL 2013

The question is: *Who learns?*

Intelligent Environments (IE) are predominantly conceptualized as technological settings that respond to user activity, by modeling human behavior and learning to anticipate human action. At the same time, emerging socio-cultural and technological phenomena such as growing technological literacy, open source culture, and new, user-centered, models of production, call for an active, creative, and productive engagement of the “users” with the technologies they utilize and the environments they inhabit. This tension posits the question: are humans the *object* or the *subject* of learning in Intelligent Environments? Motivated by this question, the Intelligent Environment (I) or Creative Learning (IECL) Workshop aims as at a discussion that will help rethink the process of “learning” in relation to the technological environment and bring forth new conceptions of “intelligence” through settings that promote creativity and user agency.

The first edition of the IECL Workshop is being organized as part of the Intelligent Environments in Education Symposium, co-located with the 9th International Conference on Intelligent Environments (IE'13). The current edition includes theoretical research and technical projects that inquire into the way environments can foster learning, enable user creativity, and develop individual and collective design intelligence. Papers presented in this workshop cover a widely diverse yet productively conversing repertoire of topics: dadaist creativity and the electrated paradigm, robotic arms and social mediation, visual calculating and design curricula, spatiality and active learning, digital fabrication and craft, and knowledge production in digital communities. This creative mix will be catalyzed by the fresh and thought-provoking keynote address by Professor Edith Ackermann, to whom we owe our gratitude for joining us in Athens.

The workshop organizers deeply thanks the Program Committee and attendees for their participation and insightful discussions.

Elena Antonopoulou, Athina Papadopoulou, Theodora Vardouli, and Eirini Vouliouri

Co-chairs IECL'13

Spatial Aspects of Active Learning

İpek KAY^{a,1} and Mine ÖZKAR^b

^a *Istanbul Technical University*

^b *Istanbul Technical University*

Abstract. This paper explores the relationship between the design of active learning places for children and intelligent environments. With focus on active learning in the digital age, it articulates various spatial relations in children's interactions with the environment. The exploration is through a proposed theoretical framework where space overarches digital tools and plays the key part in the shift to the intelligent environments of the learner-centered educational paradigm. Assuming that children generally build and share their knowledge through spatial experience, we group spatial definitions of active learning into five categories that are also schemas for physical experience. Spatial diagrams for each category are presented to guide the design bases of open-ended learning environments for children.

Keywords. Learning by doing, digital natives, self-directed learning environment, learning in digital community

Introduction

Diverse learning environments open the way for different learning experiences. Children today build knowledge in accordance with the digital environments that they are getting more and more exposed to. Ackermann observes that children “have their own ways of building and validating knowledge; of exploring, expressing, and sharing ideas; and of using the tools at their avail to find their place in the world” [1]. The learning environments now are to be designed for “digital natives” who are building knowledge with changing tools. This change is epistemic as we question “what it means to be literate, knowledgeable, intelligent, creative” in the digital culture [1] and the questioning leads to thinking about the change not as a sharp shift but a continuous process that ties our past to the future.

1. Spatial definitions for patterns of active learning

As nature and our socio-cultural environments already provide the setting for it, it is important to reclaim the physical experience in today's media ecology and build a bridge between the digital native and the pre-digital knowledge. For framing how children today adapt to and meaningfully dwell in their learning environment, we categorize five spatial definitions of active learning:

- Pluralistic Setting: Constituting a Focus

¹ İpek Kay, Istanbul Technical University. Contact email address: ipekkay@gmail.com

- Participative Boundary: Embodying an Inter-subjective Communication
- Bridge That Allows Interaction: Defining Fragments
- Interface That Allows Practices: Participating in Community
- Place That Envisions Body Movements: Discovering Routes.

The categories follow a path from children's inner world to their relationship with the community. The child continually accumulates experiences in "learning by doing" and transmits knowledge to the community. The last category brings the cyclic path back to the child's inner world through the role of the body.

Each category provides a framework for designers to interpret today's media ecology with conjunction of an active learning. The mutual relationship between event and place are continually generated by the experience. We review and conceptualize conditions of the way of forming a dynamic learning-scape. This study based on the actions of learning children can bring out both the physical and conceptual relationships in creating active learning environments.

1.1. Pluralistic Setting: Constituting a Focus

A pluralistic setting refers to a decentralized and multi-focal environment with regards to the different ways of seeing and learning that every child builds individually. This category resonates with a participatory design approach based on Kurt Lewin's model of Action Research [2]. Action Research is a participatory mode of understanding, based on a malleable boundary within a pluralistic approach. This method is closely related with children-centered learning approach in which every child becomes an active participant of own meaning-making process [3].

This category is the initial part of designing active learning places where every child can become a focus to reveal their own differences. By feeling the sense of belonging to a place, children directly participate in place making. Finding an area of interest is also essential to create a relationship with a place for children. Thus, the learning environment needs to be rich and multi-discipliner.

In formal education systems, classroom settings are often target oriented and complete according to a framework. Children are inevitably and almost entirely restricted to the inside world. This closed setting brings generic teaching ways with it. In contrast, a non-urban natural setting provides an open environment for children to build their own learning spaces. Since a non-urban natural setting is heuristic and multidimensional to encourage children to discover their interests and build their own knowledge [4].

In the digital age, a distributed environment can also reinforce a personalized learning that also provides a platform for knowledge networks [5]. Children can explore an area of interest to build their own place in this network. However, developing critical thinking is essential to distinguish one's own idea from generic knowledge acquisition.

Looking outwards into the environment invokes the need to form knowledge from within. In this setting, the emphasis is on what children possibly see rather than what the teacher conveys to them [6]. The natural environment provides this setting in two ways. Firstly, there is no overpowering boundary that children are forced to stay within. Children have an opportunity to control their distance with other elements in this environment (Figure 1).

Secondly, a setting as rich and open as nature provides hiding places for children where they are alone if they wish to observe, learn and evaluate on their own. Children can also utilize niches to keep objects related to what they have explored and learned (Figure 2).

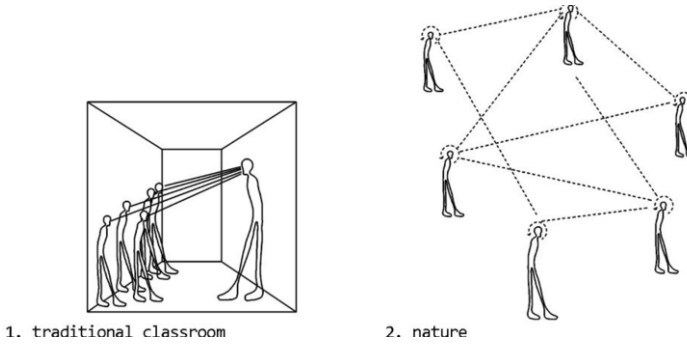

Figure 1: 1. The centralized control mechanism in the classroom, 2. Inter-connection opportunities in nature independent from a teacher.

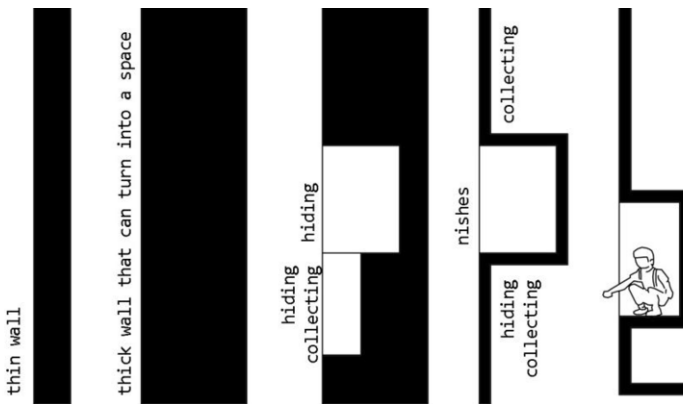

Figure 2: Space that provides niches that are randomly found in nature, for children to be alone without any interruption from place.

As a non-physical counterpart, in the abundant use of the digital media, many children today are able to create their own blogs to document and share their individual ideas. In the digital interface, these open settings introduce an active practice of constructing personal meanings and understanding. However, Ackermann [1] points out that individuals often “share before they think”. There is much room for investigating the role of digitally supported social networks in active learning.

It is obvious that pluralistic settings are essential to realize that all learning experiences are individual and a place-making activity can be a way of active learning. While a rural and natural environment provides a spatial setting to turn towards inner worlds, digital environments not only creates multi-dimensional channels to explore one's interest, but also raises doubts about whether an expression environment is enough for children to evaluate knowledge acquisition.

1.2. Participative Boundary: Embodying an Inter-subjective Communication

Participative boundary refers to the environment of an inter-subjective communication. Thus, it resonates with the notion of learning-centered approach rather than teacher-centered approach. A teacher-centered environment, where a teacher is a teller, children are only passive listeners, prevents children from actively being involved in constructing knowledge through communication with each other. Papert [7] claims that in the context of a school-dominated society, the most important effect is that “School’s teaching creates a dependence on School and a superstitious addiction to belief in its methods” via teacher-centered approach. Alternatively, people with a will to do something always find a way to acquire the relevant knowledge [7].

Constructing knowledge by integrating and sharing new learning enables individuals to reconstruct their own opinion. On the other hand, the teacher-centered approach focuses on a single direction, assuming that every child should learn same knowledge with same way [8]. A participative boundary reveals emergence and nonlinear dynamics with inter-subjective movements.

Two spatial aspects shape these dynamics. Firstly, every participant of the learning environment (including the child and the adult) has equal space to express themselves. Children are encouraged to construct their own positions to share with others. This leads to a collective memory similar to culture amongst multiple individuals. Hence, in nature instead of finished and defined environments of modern formal education system, children can individually build up own experiences. They can choose specific objects to pay attention to. It enables self-direction and being active (Figure 3). In this way, each child contributes with their own responses to the environment.

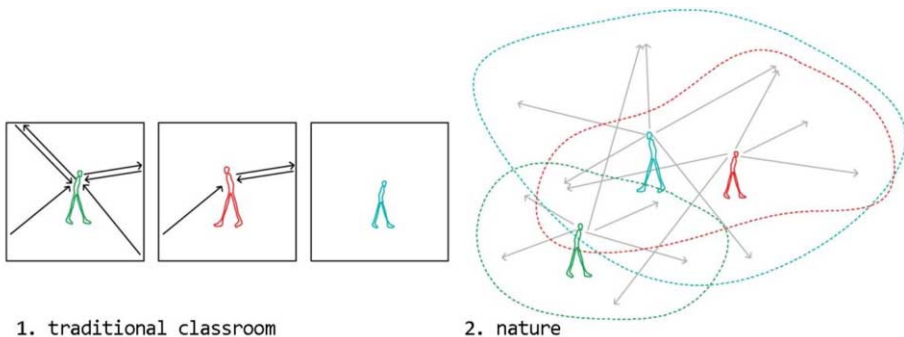

Figure 3: 1. The classroom is a limited environment to communicate 2. In nature every child can construct their environments and communications.

On the other hand, today children are growing up in a distributed media ecology where the networked public plays a central role. The networked public builds self organization and social inter-connection groups. For example online participating networks initiate online writing communities [9].

Secondly, bringing everyone to a discussion platform enhances expression. Connected settings can generate an interest-driven mechanism that children can get different opinion (feedback) from audiences who are personally interested in same context [9]. This can invent ways for everyone to meet and learn together. Our ubiquitous digital environment very well provides for such richness already, bounded

by technical as well as social protocols. However, a physical transformation is also required to open up the traditionally designed learning spaces to an abundance of relations and spatial experiences. A participative environment opens up to different experiences, and its boundary binds the multiple subjects in an interactive co-existence.

1.3. Bridge That Allows Interaction: Defining Fragments

Learning from experience constructs connection between what children do to things and what their interpretation from things in consequence [12]. The third category extends the individual in an enclosed community towards a broader culture and geography that it may be a part of. Since learning can create and bridge boundaries; it involves multiple membership and connects multiple forms of participation. There is a mutual relationship between people and the environment. Besides, this relationship builds socio-cultural dynamics. However, there is a certain disconnection between classroom learning that is based on teacher-centered approach; and socio-cultural richness where individuals can find their own interests by doing. Thus, the discovery of connections has become an important part of education [9].

Two spatial aspects are worth attention for this category. Firstly, places that can accommodate gathering reinforce the possibilities of coincidental meeting (Figure 4). In the context of spatial relations, corridors have the potential to become conducive to collective activities like a street. Similarly, courtyards can be connectors aiming to increase possibilities of encounters.

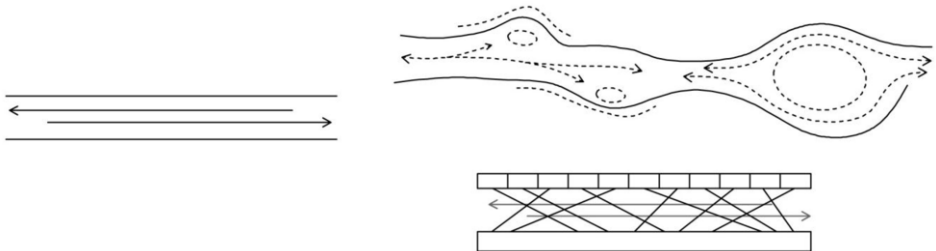

Figure 4: Place in action that includes different activities.

In the digital age, the new perspective of communication becomes a substrate for alternative embodiment for meeting. For example, online role-playing is about creating varieties of selves, about meeting new people and experiencing informal storytelling [9]. These sites have the potential to construct a learning community that supports creativity and link their own physical worlds with the wider world. If learning places co-evolve, the possibilities of meeting increases and the environment is enriched with the addition of new technological tools and interfaces [5]. With the introduction to the digital age, children are less bounded by temporal and physical constraints of interaction. In this new social sphere, outside of an authority-centered curriculum, children can explore, share ideas, find people that have similar interests simultaneously.

Secondly, if places are open to the socio-cultural environment, they provide more flexible relationships. Designing open places for interaction brings individuals of different backgrounds together who would otherwise not meet to share an opinion [1]. It can be an essential way in triggering inter-generational and dynamic learning.

For example, project-based learning is an experiential approach to engage children with investigation of authentic problems. In project-based learning, learners can decide their own approaches to a problem [11]. They can gather information from a variety of sources; hence, their learning is connected to something real. In this way, children can learn how they can communicate their acquired knowledge.

1.4. Interface That Allows Practices: Participating in Community

Dewey pointed out that learning is a life-long process that can be observed in everyday life [10]. Shared practice and culture are also parts of it. In this respect, learning belongs to the realm of experiences and practices. Thus, this interface follows the setting that is organized toward connectivity in community. Emergent structures are created by learning; they require continuity to accumulate experience. On the other hand discontinuity is essential to renegotiate meanings of experiences in order to connect our past and future. The adopted “learning by doing” pedagogy provided a tangible framework for collecting experiences and transmitting knowledge to local community [8].

Learning does not occur only at school; “learning is an ongoing and integral part of our lives” [13]. It is a part of a child’s daily experience and involves active participation in outer world through the local community. Dewey offers that most children are social beings in their community [10]. Following Vygotsky’s social development theory based on social interaction [14], a child begins to learn from the surrounding people. Individual and collective becoming depends on the intellectual structure built between child and the surrounding culture [7]. On the other hand learning in school differs from reality, because situations are described via general representations [14]. Alternatively, every place can become a learning environment [15]. Street math as an informal way of learning, [16] points to a rich form of in-situ learning where children build their knowledge with reference to their social environment. Such informal learning ways can help the recognition of learning, as an activity that can occur within the flow of everyday social life.

Physically permeable places that are open the community, provide opportunities for social interactions and learning, instead of constituting an enclosed curriculum (Figure 5).

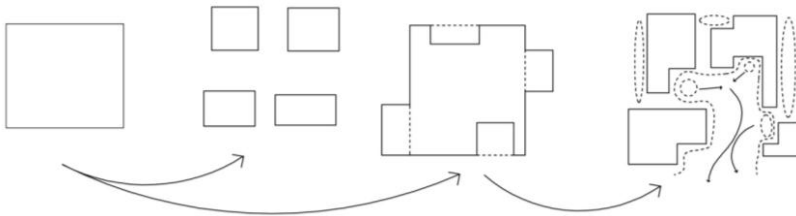

Figure 5: Constructing a relationship between learning environment and social environment.

Local elements enable the learners to be active creators of curriculum contents [5]. Curriculum framework can also be recontextualized according to the specific ethos and local community sources by learners (Figure 6). On the other hand, in the new digital media, interest-based community learning is centrifugally dispersed and cybernetically distributed into society [5].

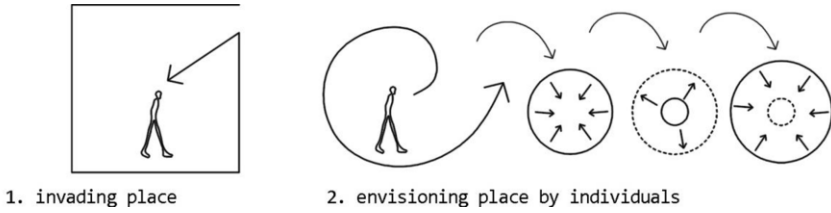

Figure 6: 1. A place that invades and imposes hierarchy and passivity. 2. Unique and dynamic environment that children can build their knowledge based on various social situations.

1.5. Interface That Allows Practices: Participating in Community

Cultural anthropologist Victor Turner shows that one knows himself better through acting, observing and participating in performance [17]. He defines the concept of “lived experience” by Wilhelm Dilthey as cumulative wisdom beyond observations and reactions. Individuals refer to their body in performance [17]. Each part of the body naturally interacts with the environment in different ways: feet walk, hands touch, eyes and ears sense, mouth communicates and expresses etc. On top of the variety inherent through many parts, the reactions of each individual are different as well. Interaction between places and performance initiates the event [18]. Dynamics of agency-place-event constantly interact with each other.

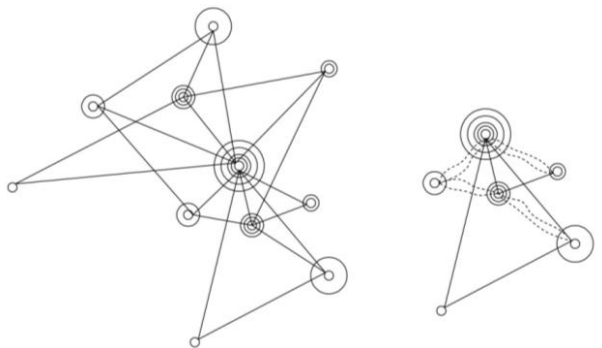

Figure 7: 1. Different networks between nodes that are belonging different individuals.

Space and schools have been providing a fertile field of research to the scholars that study spatiality; activities are intensely structured by space-time. In the digital age, “network-based technologies reveal new possibilities and meaning for interaction and participation into everyday life and learning” [5]. Nevertheless, as networks and media establish independence both from space and time, it is crucial to design environments where tools are responsive and iterative to support children’s activity and bodily performance [1]. Thus, performance of the body can reconstruct a new perceived world based on multidimensional experience [19].

2. Conclusion: the intelligence in physical space

Focusing on rethinking the learning environment in the digital age, this paper identifies five categories of spatial dimensions of active learning. These categories constitute a frame to understand the transformative power of the children's performance on both the place and the individual as they simultaneously grow. (Figure 8) The frame, in turn, may be useful in designing and evaluating interactive spaces for children from an activist pedagogical point of view. The framework as it is merely projects to future work to be used in architectural design of intelligent learning environments and tested with reference to case studies.

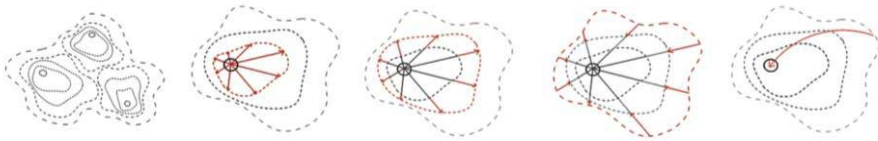

Figure 8: Illustrations of the patterns of learning of five categories towards creating spatial definitions.

While this paper does not directly dwell on particular digital technologies and how they could be used in active learning, it lays the ground on the broader framework of spatial definitions for children's performances in learning and hopes to bridge the spatial potentials of both physical and digital environments for active learning.

References

- [1] Ackermann, E., *Minds in Motion, Media in Transition Growing up in the Digital Age: Areas of Change* (2011), website: http://www.childresearch.net/papers/pdf/digital_2011_01_ACKERMANN.pdf
- [2] Sanoff, H., *Community Participation Methods in Design and Planning*, John&Wiley Sons, USA, 2000.
- [3] Piaget, J., *The Child's Conception of the World: A 20th-Century Classic of Child Psychology*, [1947] 2007.
- [4] Louv, R., *Last Child in the Woods: Saving our Children from Nature-Deficit Disorder*, Algonquin Books, 2005.
- [5] Williamson, B., *The Future of The Curriculum: School Knowledge in the Digital Age*, The MIT Press, Cambridge, 2013.
- [6] Schön, D., *The Reflective Practitioner: How Professionals Think in Action*, Basic Books, New York, 1983.
- [7] Papert, S., *Mindstorms: Children, Computers and Powerful Ideas*, Second Edition, Basic Books, 1993.
- [8] Nunes, T., Schliemann, A. D., Carraher, D. W., *Street mathematics and school mathematics and school*, Cambridge University Press, New York, 1993.
- [9] Ito, Mizuko, Kris Gutiérrez, Sonia Livingstone, Bill Penuel, Jean Rhodes, Katie Salen, Juliet Schor, Julian Sefton-Green, S. Craig Watkins., *Connected Learning: An Agenda for Research and Design*. Irvine, CA: Digital Media and Learning Research Hub, 2013.
- [10] Dewey, J., *Experience and Education*, Collier Books, New York, [1938] 1963.
- [11] Fogarty, R., *Problem-based Learning and Other Curriculum Models for the Multiple Intelligences Classroom*, Arlington Heights, IL: IRI Skylight Training and Publishing, 1997.
- [12] Dewey, J., *Democracy and Education*, Macmillan, New York, 1916.
- [13] Wenger, E., *Communities of Practice Learning, Meaning and Identity*, Cambridge University Press, United Kingdom, 2002.
- [14] Nicolopoulou, A., *Play, Cognitive Development and the Social World: Piaget, Vygotsky, and Beyond*, 1993.
- [15] Illich, V., *Deschooling Society*, 1971.
- [16] Papert, S., *The Children's Machine: Rethinking School In the Age of the Computer*, Basic Books, 1993.

- [17] Turner, V., *The Anthropology of Performance*, Paj Publications, New York, 1987.
- [18] Paterson, M., Haptic Geographies: ethnography, haptic knowledges and sensuous dispositions, *Progress in Human Geography*, 33(6) (2009), 776-778.
- [19] Vanhoutte, K., Wynants, N., Performing Phenomenology: Negotiating Presence in Intermedial Theatre, *Foundations of Science*, Vol.16, Numbers 2-3 (2011), 275-284.
- [20] Ackermann, E., Piaget's Constructivism, Papert's Constructionism: What's the difference?, *Future of learning group publication* (2001), 438.
- [21] Norberg-Schulz, C., *Genius Loci Towards a Phenomenology of Architecture*, Rizzoli, New York, 1980.
- [22] Glaserfeldt, E. von., Ackermann, Reflections on the Concept of Experience and the Role of Consciousness Unfinished Fragments, *Constructivist Foundations* 6(2) (2011), 193-203.

Transitional Physicality: The Dadaist Legacy of Creativity in the Digital Age

Rodanthi VARDOULI^{a,1}

^a*Massachusetts Institute of Technology*

Abstract. How does the historical moment of transition from the organic and the formal to the fragmentary and the processual embody the hybridized rhetorics of the digital age? The argument of this paper is that within the expanded world of information and scattered subjectivity, the tools to address the problem of creation can be drawn from the conceptual and philosophical landscape of a marginal period of time: the so-called “heroic” avant-garde. In this paper, the radical processes of creation that Dada evangelized through its polemic manifestations and propagated through its bizarre artworks, are raised to the working prototype of poiesis within the electrate paradigm of our times. The first part of the paper examines the aura of ideas gathered around objects of assemblage; the dadaist paradigm for the process of *poeticizing*, through Berlin dadaist Richard Huelsenbeck’s lecture on “The metaphysics of assemblage” and Roger Shattuck’s “The mode of juxtaposition” during the 1961 Symposium at MoMA, entitled “The art of assemblage.” The analysis focuses equally on the ideas that brought these objects into existence, and also on the ideas raised by the existence of such works. In the second part of the paper, the dadaist practice and discourse are raised into the backbone of a contemporary theory of *electracy*. This theorization is based on Professor Gregory Ulmer’s supersession of hermeneutics with the paradigm of heuristics. The process of electrate invention is also examined within the philosophical context of the Heideggerian terms of *Entbergen* (bringing forth) and *poiesis* (bring into form); the former referring to the transformation of what is already present yet invisible and the latter to a direct shift from absence to presence. The overall vision in this paper is to review Dada both as Art’s escape from its cultural and institutional history, and most importantly as a critical enterprise that evangelized a new reality through the debris of a collapsed world. The ultimate contribution of this review is to suggest a way of reviving the dadaist spirit within the emerging electrate paradigm.

Keywords. dada, electracy, fragment, assemblage, avant-garde, poiesis, entbergen

¹ varo@mit.edu

US tel: +1 (617) 513-7134

GR tel: +30 697 96 98 110

US address: 22 Suffolk Street, Cambridge, MA 02139

GR address: 37 Koutsomylion Street, Trikala, Greece 42100

1. Introduction

“We do not wish to reproduce [...] but to produce directly”
Hans Arp, 1917 [1]

“The goal of heuristics is not only to reproduce historical inventions but also to invent new
poetics”
Gregory L. Ulmer, 1994 [2]

This paper is placed within a trans-historical discourse on creativity. Attempting to problematize the notion of invention in the era of “electracy,” [3] a term with which Gregory Ulmer frames the emerging digital epoch, we may find ourselves shifting from object-oriented formal representations to a new kind of creative mentality, which appears to be highly approximate to post-linguistic mediums of multi-disciplinary nature. In what terms could the creative process and its cultural formations identify themselves, in a time where the paradigm of literacy converges with digital culture?

Founder of Berlin Dada Dr. Richard Huelsenbeck described the dadaist alienation from the notion of organic physicality as a creative force of “nothingness.” The profound conviction that founds the basis of the present argument is that we live in the dadaist legacy of transition, in which creativity signifies an attitude of constant rupture with the articulated physicality (physical objects). This liberating impulse signifies a never-ending channeling of the divine forces of creation into ever-evolving physical forms, which exist in a state of constant flux. The overhaul of temporary physical structures manifests an act of constant poeticizing beyond the formal constraints of language and history. The profound conviction in this paper is that, if taken out of its parenthetical historical moment, the dadaist spirit of creation might arise as a valid and explanatory contemporary worldview, that superposes the chaotic and the fragmentary over the organic and the complete.

In the stormy periods that succeeded the First World War, the radical avant-gardist rhetorics which were soon translated into the fierce polemics of the Dadaist revolutionaries, manifested the sublation of art into life. Avant-garde artists in Zurich, Paris, Berlin and Hannover attempted to re-align their artistic practices with the very praxis of life. They attempted to liberate the latent creative potential that was imprisoned within instrumentalised rationality and mechanized social order. Their vision was to revolutionize both the conception of the world (logic) and the very experience of reality itself (being-in-the-world.)

In this paper, the early twentieth century dadaist declarations of a hyper-historical “spirit of negation that contains the ferment of the future [4]” provide the focusing lens for the poetics of the electracy period of time. The notion of *transitional form* or *multi-channeled performance* dates back at a time in which the multi-disciplinary nature of the creative process and the process of meaning-making beyond symbolic significance was established as the (non)model of creation. Through a parallel discourse on Heideggerian *poiesis* as the language of metaphysics, and the early 20th century artistic attacks on the established status quo, manifested through the non-organic artworks of assemblage, Dadaism is raised to the **prophecy** of electracy invention.

How is the dadaist poetics of spiritual revelation prophetically applicable to the era of electracy? How may the dadaist poetics of assemblage, the never-ending act of fragmenting organic meaning and reassembling the fragments within new contexts of re-signification, provide a kind of dialectical synthesis of what Heidegger called “the

hermeneutic process of art” [4] and today's creative postulate for a constant re-writing of the world? How is the value of the transitional form manifested through this creative process of constant re-signification?

2. The Art of Assemblage, MOMA, 1961

“Dada anticipated the science of Cybernetics on an aesthetic level”
Richard Huelsenbeck, 1961

Creative tension accompanied with wry humor and dadaist irony arose between the six men who formed the panel of speakers at the 1961 symposium “The Art of Assemblage” at MOMA in New York. [5] We were already in a neo-avant-gardist period of time. The Apple of Discord: what Dada really *is/was* and what status could the unorthodox objects of assemblage that it produced, claim at a time when Dada as movement in the Arts had already dissolved. In this early time of Cybernetics, the computer has already started to conceptually replace the late modernist notion of the machine in critical theory discourses. The Question: Was Dada anything more than a cultural firework? Could the dadaist practices ever be recaptured and iterated as such? Or shall the spirit of Dada, that “enormous short-circuit” that cracked the backbone of rational and instrumentalised thought during World War I, “forever be with us”? [6]

The Symposium set itself the objective of addressing certain ideas, attitudes, and postulates raised by the existence of the objects featuring in the “assemblage exhibition on the third floor.” [7] The driving force that brought both the exhibition and the symposium into being was that the ideas around the objects of *assemblage*, i.e. combined objects of diverse materials/fragments that had been detached from their provenance and initial signification, were rich and worthy of study, including “sharp edges and points.” [8]

Professor Roger Shattuck initiated the debate by asserting that the advent of *montage*, the principle device of modern art and innovation, was a “change in temper.” Shattuck described montage as the “mode of juxtaposition:” an act of disrupting formal coherence by introducing formally inconvenient or unexpected elements to the line of the development of the artwork. He focused on a moment of a transition, a shift in method. “The ratio was reversed,” he said, when the *jolts*, the unsuitable components, were no longer the alien elements in an artwork, but a conscious juxtaposition of unconnected elements one beside the other. According to Shattuck, the absence of any coherent meaning prohibited the spectator from defining the object as a form. “We have taken refuge,” he said “in saying that the parts have been *assembled*.” The shift that Shattuck referred to, was from Cubism and Futurism to Dada and Surrealism. From the juxtaposition of homogenous elements, that disrupted the conventions of the immobility of the observer and the singleness of the time in which he observes, another paradigm of juxtaposition had emerged: in the dadaist objects of assemblage, the fragments had no apparent connection “unless one detours through the underground channels of choice or chance and unconscious association.” [9] In the context of Shattuck's words, the term *juxtaposition* implied a new cultural mode. For Shattuck, the shift from Cubism and Futurism to Dada and Surrealism was analogous to the stylistic disjunction between a new *classic* style and a new *romantic* style respectively. In the first case, reality is still depicted, yet in its modern expression: in a simultaneity of time and motion. In the second case, the abruptness and fragmentary nature of a “*réalité*

nouvelle” dictates for a new positioning of man within a new state of seeing, thinking and remembering; a new type of experiencing the world.

Describing the effect of this new mode of juxtaposing elements beyond the ordering capacities of the human mind, Shattuck crystallized both a spiritual and aesthetic return to *zero*, “a reversion to dead level,” [10] and to a condition in which the tension between the heterogeneous components insists. In the case of zero effect, the spectator's experience may be described as *shock*: the reaction against the scandal when meaning is absent. Scandal however may only happen once per spectator. It is unique. Whereas the second type of effect is a new state of mind, in which the creative forces remain unresolved and sustained into the heterogeneous associations, until they are reactivated in a new context of signification. Beyond the characteristic gleeful destructiveness and spectator participation in the artistic act, Shattuck stated that the dadaist spirit emerging from the works of juxtaposition sacrificed the preeminence of art as object at the service of a vivid performance that either shatters or repulses. Fifty years later, the idea that emerges from these early assembled art-forms seems to prophetically describe the contemporary electrate postulate for a multi-channelled experience, “the unsettling passage from art to life, from painting to reality.”

According to Shattuck, every work of assemblage raised a serious issue, both compositionally and metaphysically: “Is a painting anything more than a frame-up?” he questioned. [11] The traditional rectangular frame of the Renaissance artwork, that laid out a universe within which the relationships were self-sufficient. However, the juxtaposition of an ordinary object “stuck” in the middle of the painting, wrenched the frame out of its alignment and inclosed the by-stander to a new reality, in which innumerable possibilities of re-signification co-exist. As Shattuck astutely described this bizarre new reality, in the end we ourselves are also “*assembled* into the frameless work the frames us.” [12] When a work of assemblage is made, a new object-of-the-world emerges. This object is no longer a unified system of internal correlations over which we can ponder from a distance. The object comes to life to importune us to project its field of force beyond and around us.

Taking step on Shattuck's analysis on the mode of juxtaposition, Berlin dadaist and at the time practicing psychiatrist in New York, Professor Richard Huelsenbeck emphasized the creative potential inherent in this new mode of creation. The dadaist faith in zero and nothingness, especially regarding the importance of the creative individual, is what brings Dada close to the metaphysics of Electracy and at the center of a contemporary problematization of *poiesis* within the world of post-humous emergences. Huelsenbeck described a change of scene in the subject-object relationship; a process of redefining the position of the creative subject towards its product of creation. The spirit of Dada and the dadaist objects of creation were the manifestation of a new condition, which according to Huelsenbeck, was at the time “felt stronger than ever before.” The objects themselves had started to *mobilize*. This mobilization of objects, as implied by Shattuck and explicitly celebrated by Huelsenbeck, had a tremendous effect on Dada's nihilistic attitude.

According to Huelsenbeck, Dada's philosophy of self-irony and doubt, did not allow taking the act of creation “seriously.” The Berlin dadaist strongly argued that neither Dada nor its works of assemblage were to be treated historically. Dada emerged as a spirit of revolt during the years of World War I, at a time when any logic, religion, philosophy or morality had already started to dissolve and collapse. The spirit of Dada arose with the purpose to manifest that within a world of rationality, there was an absolute absence of meaning. Dada seeks to introduce a new world; a world of multiple

possible emergences and significances. Its philosophy was at the same time a philosophy of nihilism; of a nothingness that bore a multitude of potentialities for meaning-making. Dada's nihilistic mentality did not dictate an attitude of suicidal vanity. Instead it ordered for a new positioning of man towards himself and the objects of the world qne for man's spiritual realization through an act of constant constructions and destructions. Dada aimed for the re-creation of a meaningful emergence of the world through the re-arrangement of the debris of its previous collapsed structure. The senseless collapsed reality of the World Wars became the creative material for a forceful liberation of meaning from previous structural constraints.

As Dr. Huelsenbeck described, the only principle in the universe was *movement*. The failure of fallible ideologies and systems of thought during the World Wars had to be succeeded by a new state of mind. In a new condition in which everything moves, and things themselves march toward man "in parades," [13] Dada's nihilism should by any means be protected from forming a new value. If the belief in nothingness became a new ideology, Dada should by principle attack itself. This postulate for an autoimmune condition, seems very approximate to an existential condition that Heidegger called "abandoned man." Heidegger referred to a condition within which man, after watching all his values crumble during the two World Wars, he felt completely isolated and atomized. In this condition of abandonment, "having nothing, being nothing, hoping nothing also dictated a change in the subject-object relationship." [14] Man developed the primal desire to live like a caveman again and seek for a new meaning for his existence in the world. However, he was now enriched with the profound conviction that there was no longer one true meaning to reveal. The collapse of the World War reality faced man upon the only truth, that there was a multitude of significations in the world, waiting to be framed and constructed.

Huelsenbeck therefore regarded *irony* as the only (non)principle. Irony arose as the attitude that could best describe man's new condition within a world where all happenings came to him, rather than he himself going to them. This attitude of irony denoted an irrationality of the creative forces and a subsequent elimination of the creator's importance in the act of creation. Paradoxically, this new supremacy of unknown forces such as chance over man's own creative force, was at the same time a promise to revel man's most intimate sensorial drives. The "self-accumulated, self-happening, self-organizing power" [15] of the object itself demonstrated that the creative principle had been freed from the hands and the mind of man. Man was now an existential observer within a world of mystery and potential.

3. Creating within Electracy

"The nature of art is poetry. The nature of poetry is the founding of truth ... founding as bestowing, as grounding, as beginning."
Martin Heidegger [16]

Going back to the fundamental question of the paper: *What kind of form/physicality can embody the emerging paradigm of invention within the electronic culture of the media age?*

Paraphrasing the dadaist paradigm, the answer seems to point at a creative re-invention of the world and a re-writing of its history through the liberation of knowledge using the arts and sciences as models/tutors. We shall redefine the creative process by embodying the experience of invention in it.

What was Dada's contribution to cultural history? Inquiring into the marvelous world of irrationality that permeated Europe in the years when the dadaist spirit was born out of the ashes of a dissolved world, we find ourselves before a tutor of "pure psychic automation" as was later celebrated by the Surrealists. Dada was the virus of freedom, rebellious anarchic and highly contagious. The sense-less automatism it celebrated appears as a synonym for hidden realities within the existing order. Dadaist chance and automatism manifested itself as an intervention of mysterious creative forces of the psyche leading to pure poesis.

The vision of reviving the dadaist spirit in the present time, is a vision of channeling creative apocalyptic forces to redeem man as a significant motivating *myth*. In the case of historiography however, such a vision requires critical scrutiny. [17] All constitutive characteristics of dadaist artwork production, such as the machine, this revolutionary instrument against plutocracy that became the symbol of the new order, the laws of chance, personalism and the spit in the eye for the ethos of accountancy, may be summed into a dialectic schema. In this schema, the thesis is represented by the imaginative potential of the machine; its clarity of mechanism. The conceptual antithesis is abstraction, as generated by chance. The product of their synthesis is the revelation of the *I*, situated within the very act of creation.

"Dada Lives![18]" declared Huelsenbeck in the 1960's. His slogan attempted to maintain the dadaist vision of aligning the "I" with a path toward personal creation, through a conscious appeal to nihilism and the complete surrender to the theories and practices of the machine. After Dada as a movement was dead, statism, or the praise of form, gave its position once and for all to a new non-conformist art that no longer embodied a style of appearance, but a formula; a *process*.

The deep conviction in this paper is that instead of writing a history for this "object of universal curiosity" [19] called Dada, a general apologia for the spirit behind its practices could interpret the dadaist mystery as a praise of personalism within a time of total abandonment. Dada could therefore be seen as the "the irresistible undercurrent of thought preparing to rise to the surface, seeking formulation." [20] Dada was not a farce generated from a motley group of rebellious artists and intellectuals in the bizarre setting of Cabaret Voltaire and the Paris cafes of the early 1910's, the traditional breeding ground of intellectual and moral libertinism. Detaching Dada from the narrow interpretations of subversive exhibitionism, a new attitude can be extracted. This new attitude refers to a cohabitation of nihilism and constructivism within an act of simultaneous chaos and a will for formulation. The "let it run until it happens" dadaist motto seems to describe the exact short of self-elimination in order for something entirely new to arise, while at the same time it was at this exact state of mind that Beuys would later find the ontology for his postulate for "everyone an artist." [21]

4. Epilogue

“Creation survives in fragments under the ruins of a world for which we can no longer find expression.”
W. Wiedle [22]

The intuitive channeling of the forces of creation into forms of transitional spiritual value, as manifested by the Dada spirit, was ultimately swollen by the onslaught of History. In the march of time, Dada was reduced to a fleeting act of post-war negation; an anarchic gesture with an aestheticizing tendency. However, the metaphysics of the Dada movement seem to embody the very spirit of our times: the “subjectless subjectivity” of the digital age seems to be tightly bonded to the processes of creation as a significant act of invention.

In this paper, the Dada movement was regarded in its great affinity to pure **Theory**. As a dialectic synthesis of the World-War order of things and the avant-gardist polemics of spiritual liberation, the dadaist evangelisms of transcending History seem to provide the alive and kicking post-Hegelian paradigm for contemporary processes of invention, while we observe ourselves become electrate.

5. Afterword

“Dada has always been a thing of the present, hence its posthumous activity.” [23] When Marcel Duchamp offered a urinal as his sculptural contribution to a public exhibition, he expressed in a most authentic way a profound will to formulation through nothingness. His true contribution however, surpassed the physicality of his object and was raised to a discourse beyond History. Within a sense-less world, the avant-gardist discourse seems to arrive to the arcana of new plasticity and new poetics; to a post-Hegelian spiritual realization through the tension between predictive certainty and freedom “I was there then. And indeed we are all there now,” manifested Alford.

In this paper, the vision was to free the Dada movement from a sterile discourse of Philistine or avant-garde art, and to raise it to the ethos of creative élan, surmounting the constraints of History. The was analyzed as a chaotic impulse meeting its constructive alternative. However, the effect of the dadaist shock inevitably faded with time, as shock creates its own immunity. The subversive form eventually became conventional; re-mediated by the very norms that it initially attempted to subvert. This paper suggests a reading of Dada not as the synthesizer of modern art but as an apocalyptic moment within the History of Ideas, which established an anti-conformist transgression of any quest for certainty.

“Once kick the world and the world and you will live together at a reasonably good understanding” declared Swift. [24] Let me conclude this presentation in the spirit of Dada, by redefining creativity as an act of constant break-down of solidity, an ebullience of invention and exploration beyond the realm of the visible and the rational, guided by a violent disgust at the old, narrow security.

References

- [1] P. Crowther, I. Wünsche, *“Meanings of abstract art : between nature and theory,”* New York : Routledge, 2012.
- [2] G. Ulmer, *“Heuretics: The Logic of Invention,”* The Johns Hopkins University Press, 1994
- [3] In his 1989 “Teletheory” (3), Gregory Ulmer introduced the term “electracy” to describe apparatus of the emerging digital epoch, that calls attention to the multidisciplinary nature of the invention process. The term comes from *electricity*; “the power running our equipment which we sometimes take for granted”, in Ulmer’s words, and *trace*; a keyword in the Derridean philosophy, that pushes the theory of signification beyond the linguistic sign into a post-medium effect of inconceivable nature. G.L Ulmer, *“Teletheory: Grammatology in the Age of Video.”* New York: Routledge, 1989.
- [4] C.W.E. Bigsby, *“Dada & Surrealism, (Critical Idiom)”* Methuen young books, distributed in the U.S.A. by Barnes and Noble, 1972, p. 12.
- [5] “The Art of Assemblage” symposium (1961) at MOMA, Historic audio from the Museum of Modern Art: 1961. Recorded October 19, 1961. Originally aired 5/10/04. (2 hours) Available at <http://artonair.org/play/7692/show/theart-of-assemblage-1961>
- [6] William Seitz 's introductory speech during the “Art of Assemblage” symposium at MOMA, Ibid.
- [7] Roger Shattuck's “The Mode of Juxtaposition” during the “Art of Assemblage” symposium at MOMA. Ibid.
- [8] Ibid.
- [9] Ibid.
- [10] Ibid.
- [11] Ibid.
- [12] Ibid.
- [13] Ibid.
- [14] Ibid.
- [15] Ibid.
- [16] M. Heidegger, *Basic Writings, “On the Origin of the Work of Art.”* 1st Harper Perennial Modern Thought Edition., ed. David Farrell Krell, New York: HarperCollins, 2008.
- [17] Lawrence D. Steefel, Jr., “Review of “Dada: Art and Anti-Art” by Hans Richter,” *Art Journal* , Vol. 26, No. 3 (Spring, 1967), pp. 328-330, published by College Art Association.
- [18] J. Alford, “The Prophet and the Playboy "Dada Was Not a Farce,” *College Art Journal*, Vol. 11, No. 4 (Summer, 1952), pp. 269-276, published by College Art Association.
- [19] Lawrence D. Steefel, Jr., “Review of “Dada: Art and Anti-Art” by Hans Richter,” *Art Journal* , Vol. 26, No. 3 (Spring, 1967), pp. 328-330, published by College Art Association.
- [20] R. Motherwell, “The Dada Painters and Poets. An Anthology.” Second Edition, Wittenborn Art Books, Inc. p. 255, 1979.
- [21] C. Mesch, V. Michely “Joseph Beuys: The Reader”
- [22] H. Richter, “Dada Art and Anti-Art.” p.332
- [23] R. Motherwell, “The Dada Painters and Poets. An Anthology.” Second Edition, Wittenborn Art Books, Inc. p. 127, 1979.
- [24] J. Swift, “A Letter of Advice to a Young Poet,” *English Essays: Sidney to Macaulay, The Harvard Classics, 1909-1914.*

Matter and Knowledge Among Digital Communities

Maroula BACHARIDOU^{a,1} and Georgios ADAMOPOULOS^b

^aNTUA School of Architecture, Athens

^bNTUA School of Architecture, Athens

Abstract. At the threshold between the industrial and the digital crafting era, this paper discusses the notions that both today's designers and users are grappling with. Learning from pre-industrial design and crafting environments, considered as 'intelligent' due to their responsive results, mostly achieved using empirically-oriented methods, we envision the creation of a new environment, this time in the age of scientific, technological and computational applications. Based on interdisciplinary collaboration and global data collection and analysis regarding crafting materials and methods, this environment acts both as a design tool and a knowledge-propagation model among digital communities: simulating the complex behaviors and properties of matter through a user-friendly, real-time computer interface, this environment educates and assists users in the creation and manipulation of their personal -optimized to local conditions and needs- artifacts.

Keywords. crafting, tacit knowledge, computational thinking, interdisciplinary design, coding, participatory design, digital commons

Introduction: Concerns and Observations

In his book 'City Of Bits' in 1994, William Mitchell introduces a new type of space in the cities, one that has assimilated the functions of the physical places and translated them into digital terms: places are replaced by 'spaces' [1], and, via internet, local differentiations among diverse geographical communities enter the global spectrum. Regarding communication and propagation of knowledge in today's cities, W. Mitchell was rather prophetic: the main amount of information among both local and global communities gets distributed in virtual spaces. However, cities, like their inhabitants, do not cease having physical substance: today's citizens seem to share two environments: the physical and the digital. What kind of information could these two environments exchange?

This paper discusses the propagation of structural and material knowledge among today's designer and non-designer communities. Inducement for our attempt is the ongoing shift of crafting from the industrial to the digital era, through currently emerging design and manufacturing technologies. Comparing the conception, design and production methods between the two -currently coexisting- crafting eras, we notice a rather sharp contrast: that of the user's role in the design process. Industrial era, in general and modernism, in particular, in search of design solutions that would be

¹ Maroula Bacharidou, National Technical University of Athens. Contact email address: marbah7@gmail.com

standardized as 'universal optima' for the 'average person' in the 'average society' [2], was driven to mechanistic design processes, which, as Alexander Tzonis notices in his article 'Aspects of Mechanization in design: the rise, evolution and impact of mechanics in architecture' in 1980, were considered for almost the rest of 20th century 'legitimate' [3] due to their generalized philosophy of construction. These processes, in many cases, proved unresponsive to local climatological, sociological and cultural conditions. With the release of CAD environments in the end of 1960's until the recent past, architects, being communicants of the design approaches of the industrial era, often reproduced the generalized methods of the industrial design culture. Victor Weisskopf, discussing with Richard Sennett about the development of CAD environments soon after their release, argues that their users incur the hazard of remaining 'passive' [4] observers of the computational evolution if they do not contend to comprehend the way these environments operate and behave: Weisskopf probably meant that the use of computational design should coincide with the user's ability to analyze data, identify possible solutions, give feedback to the design process, notions later embedded in the term 'computational thinking', first used and analyzed by Seymour Papert in 1996 [5]. Almost half a century after the introduction of CAD environments in the design process, if matter is the mediator between man and design, how could this relationship evolve when design develops computationally?

Through this paper, we aim to outline the components of an intelligent environment that would enhance human perception while designing and propagating knowledge digitally. Regarding matter, Manuel DeLanda's article 'Material Complexity' in 2004 drives our assumption towards a review of material knowledge propagation of the past, and especially of the pre-industrial era, ascertaining that the study of the complexity and variability of behavior of materials has traditionally been 'the concern of empirically oriented craftsmen or engineers, not of philosophers or scientists' [6]. If the development of tacit knowledge lead craftsmen of the pre-industrial era to responsive results while operating under participatory design processes, we are looking forward to examine how notions such as participatory design and tacit knowledge can get effectively introduced into computational design. An intelligent environment of the past inspires us to imagine a future one.

1. Tactile vs Virtual: Tacit and explicit knowledge among crafting communities

Regarding crafting, if tradition is considered the technique that corresponds to local material needs -imparting knowledge from one generation to the next- while computation consists a method which aims, through the digital use of scientific tools, to design and construct the living human environment -propagating virtually among designer communities- a question that arises while trying to borrow learning methods from such a -chronically and technologically – distant environment is the reason we consider it intelligent. In his article 'Material Complexity', Manuel DeLanda assumes that early philosophers like Aristotle may have derived from observation with those 'whose eyes had seen and whose fingers had felt the intricacies of the behavior of materials during thermal processing or as they were shaped by chipping, cutting or plastic deformation' [6]. This kind of communication between human, haptic

action and material attributes was amended during the first attempts for industrial production, where, according to Richard Sennett, 'the smart machine separated human mental understanding from repetitive, instructive, hands-on learning' [4]. If that is true, the industrial era may not have to teach us much about creative learning in structural methods, in opposition to the pre-industrial one. Back then, efficiency and knowledge propagation were achieved by the user's haptic and visual interaction with the artifact. If 'intelligent environments have been traditionally conceptualized as technological settings that respond to user activity' [7], then craftsmen environments, regarding the interaction between the materials and the craftsmen through real scale, trial and error contact, might be considered as such.

But, how could we set under a methodology such an -at first look- intuitive process? What is the role of intuition in the development of a common structural language? Denis Diderot, during his attempt in the early 1750s to compile the 'Encyclopédie', alternatively entitled as 'Systematic Dictionary of the Sciences, Arts and Crafts', notices that 'major part of craftsmen skills derives from tacit knowledge' [4]: in craftsmen workshops, people may know how to make something properly but they often cannot formulate in words things they know. As tacit knowledge R. Sennett defines 'the kind of knowledge that cannot be transmitted and codified in words, the knowledge of the thousand small movements whose aggregation drives to the development of a technique' [4], noticing that 'a proper workshop bases its activities within the interplay between tacit knowledge and self-conscious awareness'. Sennett's exhortation on the occasion of Diderot's attempt leads us to an important realization: if learning can not prosper among a community without a common and accessible 'dictionary', intuition could have limited impacts on that language as it could not be codified in order to be expanded to other members of the community. On the other hand, if its users constructed that 'dictionary' in a way that would explicitly introduce and embed intuitive decisions and manipulations, creating a variety of solutions, learning could be highly creative. Then, the methodology of such a system would consist of its dynamics of anticipating the human action through a strong matter-manipulating background: a virtual, 'lectical' one – capable of getting implemented physically.

In the age of wide- spread knowledge via the Internet, what kind of inputs would a dynamic, digital, structural 'Systematic, Universal Dictionary' accept? If techniques of the past prove the claim of Michael Polanyi that 'we can know more than we can tell' [8], in the case of virtual manipulation of matter the user faces an unprecedented need: that of being able of digitally formulating and de-coding knowledge in order to know more- through other users' edits in that 'dictionary'. If Sennett's mention for counterbalance between tacit and explicit knowledge was current in craftsmen environments, it still is in the age of digital technologies: then, this counterbalance was required to be expressed in a tactile way and, today, in a virtual.

Taking a close look at the emerging technologies of today and considering the rapid advances in material science (e.g. Objet© Digital Materials), the increasing efficiency and ease-of-use of scientific simulation software (Sawapan's 'Topostruct',

CFD software, Environmental Analysis software), an apparent vivid tendency for more accessible and user-friendly interface concepts (Nervous Systems' 'Cellcycle', Tinkercad) in addition to the remarkably rapid growth of web-based 3d printing services (Shapeways, i.materialize) one can see that the building blocks for an intuitive, yet highly sophisticated design process which enables the designer, through digital test and verification to take better informed decisions, are present. Daniel Piker in his article 'The Building of Algorithmic Thought' in *Architectural Design: Computation Works* in 2013 states: 'Just as a craftsman develops a sophisticated feel for a material through time spent working with it, if we can interact and play with virtual materials in our CAD programs then we can extend our intuition and develop a more sophisticated feel for their constraints and possibilities' [9].

2. Statement: Matter as information-bearing entity

2.1. Digital responsiveness learning from pre-industrial intelligence

Talking about manipulation of matter among pre-industrial communities specifically in the digital era, would be a trivial issue if it did not offer design a great advantage: that of being responsive to the user's needs. Nicholas Negroponte in 'Soft architecture machines' in 1976, examining the 'indigenous' [10] architecture of traditional, local settlements as a model of responsiveness, notices that 'each of them had developed a system resulting of citizens building their own homes, creating relationships between them corresponding to the local needs and material facilities' [9]. This kind of structural 'vernacular' [10] corresponded to the needs of the user and, at the same time, the community he belonged, translating 'global forces to local' [10]. The discussion for matter manipulation in traditional techniques would be a nostalgic flashback to the past if it did not have to teach us design virtues such as these of adaption to the local climate and local material supplies, responsiveness to the user's needs, participatory design. Driven by the motivation for the development of a responsive and accessible structural method, the attempts of traditional communities lead to results that make us wonder whether computational thinking, design and crafting coincides with the use of the computational tool.

Today, in an advanced technological reality, digital design and manufacturing- whether industrial or architectural- is still grappling with the notions of responsiveness and adaptability, notions already apparent in past environments. Those environments, on the one hand optimized user 'inputs', while developing, on the other hand, a direct type of local design 'language'. We aim to examine these two virtues in digital terms, in order for them to be efficiently incorporated into the contemporary design processes, while exploring new kinds of intelligence that could be developed between matter and user .Our questioning leads us back to the theory of Manuel DeLanda about the

complexity of materials and its capabilities for a more responsive design. If workshops' institutions during the pre-industrial era were the empirical and technical investigation of physical laws that transform matter from one form to another, craftsmen seem to have achieved to comprehend them: these laws were translated into attributes, based on which a series of practices, techniques and methods was developed 'outside scientific environments' [6]. Working with -mostly local- clay, stone, iron, wood, craftsmen of the pre-industrial era came across forces and behaviors of matter, which they were motivated to confront. Today, thanks to the development of material science, computer science, advanced design and manufacturing tools and methods, we can not only name with scientific and structural terms the once verbally expressed attributes of matter – strong, porous, glossy, translucent, water-permeable- but analyze, parameterize, configure, customize and examine the potentials of those attributes in a new kind of responsive, adaptive design. These behaviors of matter expressed laws of nature, laws able to be expressed now with the use of algorithms, fitness functions and other topological tools, as Manuel DeLanda introduces in his book ' *Philosophy and Simulation: The Emergence of Synthetic Reason*' in 2011 [11].

Considering the current computational tools' manipulation capabilities regarding matter, we propose an environment of creative learning, which will efficiently shift production from modernism's truncating approach of the 'average user' in the 'average society' and devise a method where every particularity among the various inputs during the design task matters and affects the end-result. The development of such a digital and structural database, implies, at a first stage, the comprehension of material particularities and capacities, at a second their codification and transmission into digital matter and, at a third one, its return to the users. By creating an intelligent environment that will anticipate human action, we believe that users will develop digital matter – manipulating skills. This aim requires the creation of a digitally mediated 'dictionary', which will receive explicit information as inputs, while allowing the development of the users' tacit knowledge through their experience.

2.2. Digital Entities: From interdisciplinarity to human interaction

At the threshold between industrial and digital design and crafting era, matter, according to Manuel DeLanda, has to return from the situation of 'simple and uniform' to the one of 'complex and variable' [6] that used to have during the early attempts of the pre-industrial era. DeLanda argues that 'explaining the physical basis of ductility involved a radical conceptual change: scientists had to stop viewing metals in static terms, and began looking at them as dynamical systems' [6]. Those complex materials- systems present various characteristic states which he names 'singularities' [6], states that can be expressed as points in the fitness function describing the behavior of the material under the application of certain forces. But how could these 'singularities' be defined, digitized and manipulated by both designers and users?

We propose a digital morphogenesis media that will embed interdisciplinary processes and interaction in a user-friendly design interface, while fostering designers to learn and develop new techniques and structural methods. Keeping in mind Negroponte's mention for a 'artificial, domestic ecosystem' [10], this

environment will compile the digital base for the creation of material and structural genotypes that, interactive with the user's inputs will produce adaptive phenotypes. Through this database, it would be interesting for both non-contributor users and members of the contributor community to examine the localities of that digital, interactive structural 'dictionary', in which, sharing Friedman's vision, 'the enormous variety of intuitive solutions which can be invented by a large number of future users might give an incredible richness to the design process' [10].

In order such notions to be efficiently incorporated into the design process, the development of digital entities bearing variable properties is required, whether those entities are construction or production methods, materials, everyday objects, building components or building themselves. The realization of the need for complex variable properties of this kind of digitally mediated structural 'dictionary' leads us to an important matter concerning the digital era generally, and digital design, specifically. That is, the amount of information bore by a given entity that a user or designer can actually comprehend and interact. Regarding digital design, the increasing sophistication and complexity of design entities, enabled by constant advances in computer software and hardware, doesn't necessarily lead to an increase of the efficiency or sophistication of the way designers deal with those entities, often driving designers to geometric-driven approaches.

These things considered, one question arises: If complex design entities with variable properties need to be defined in order for design to become more context sensitive, and if, at the same time, end-users of digital tools need to manipulate those entities in an intuitive and direct way, could then a design system be devised, in which the properties of those complex design entities are reassembled into easily comprehensible parameters that enable users to effectively and intuitively express their tacit intentions?

3. Methods: Analyzing, Reassembling, Interacting

The Creative learning environment we envision would essentially be constituted of a back and a front end and its functional model is schematically represented in Figure 1.

3.1. A back end:

The back-end would be realized through the collective efforts of a Contributor Community (including-but not limited to- engineers, climatologists, material scientists, architects, designers, craftsmen, sociologists, economists, computer programmers). This interdisciplinary community would be responsible for the systematic recording and collection of global data, under the scope of determining, in an explicit way, the local differentiations of matter and structure regarding climate, culture and ecology. These collective efforts would be focused in aspects such as the behavior of matter (e.g. structural, chemical, thermal, electromagnetic) and the endurance of materials under diverse climates, in factors such as material scarcity and resource depletion, local expertise and construction methods (both traditional and contemporary) as well as in production waste management, recycling and sustainability matters. The results of this

ongoing dynamic collaboration should be analyzed, dissected, cross-referenced between the various disciplines and eventually laid out onto a common ground.

This common ground would prove essential for the systematization of those heterogeneous data sets into a unifying generalized data model, a virtual entity with explicit properties, each of which would reflect the aforementioned research and inhere the potentialities, particularities and diversities of loci and matter. In order a complex data model with such properties to be actually useful for the end user-designer, the analyzed and “decoded” data should be reassembled, re-encoded and distilled into a comprehensible set of parameters, which brings us to the front-end of the proposed Environment.

3.2. A front end:

By front-end, a user-friendly computer interface is implied, an interpretation of the complex scientific data into a language meaningful to -and comprehensible by- the users, that would enable the effective expression of their implicit knowledge. A digital language consisting of parameter controllers, through which the users would intuitively interact with digital entities and digital matter according to their needs/desires and/or their local conditions and receive immediate simulations and information regarding the optimality of their choices.

Through rich and engaging visual and lectical feedback, this virtual Intelligent Environment would educate both users and designers about particularities in the behavior of matter and guide them into wiser design choices, essentially developing within them a stronger material and locus sense, conscience and comprehension. The evolution of this system would lead to a rich dynamic library of user-created, optimized digital entities (materials, objects, building components) to be emerged, consequently resulting through this decentralized and distributed design process and with the assistance of digital manufacturing methods such as 3d printing, into physical entities, optimally adapted to each user and his immediate environment.

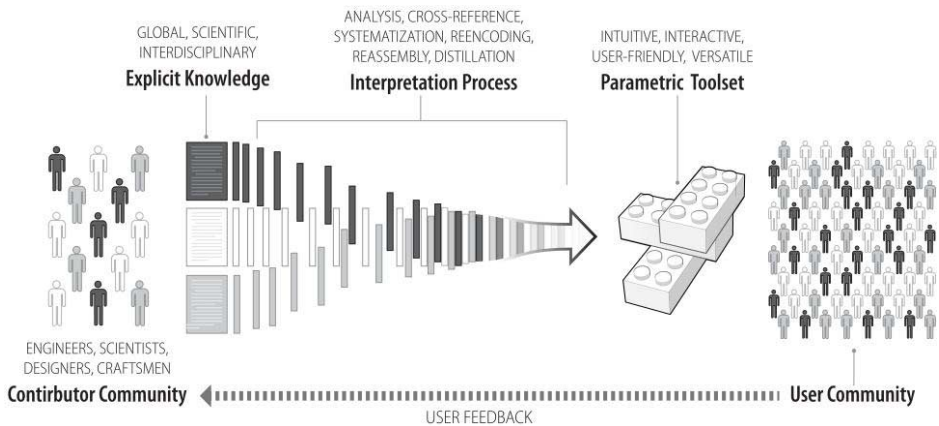

Figure 1. Schematic representation of the knowledge propagation model.

4. Discussion: Matter & Knowledge in the age of 'time-space compression'

In the current age where knowledge spreads mostly digitally while architecture still develops in diverse geographical, sociological and cultural environments, Doreen Massey, in her article 'A global sense of place' in 1994 induces us to a 'progressive sense of place, one which would fit in with the current global local times, feelings and relations' [12]. If computational design tools give us the opportunity to develop methods and techniques towards a more responsive, accessible and adaptive architecture, how could they be expanded and enriched in the context of a digital, dynamic environment available to global users?

Through this paper, various critical topics concerning today's society are stimulated, including technological obscurantism: the ability of people to shape on their own their immediate environment and the role of the scientific community in the propagation of explicit knowledge. In an age where the flows of information and goods move at unprecedented speeds through the Internet and communication has overcome almost any geographical and temporal barrier, an age of Massey's 'extreme time and space compression' [12], which should be the contemporary structures of knowledge propagation and especially what should the role of the scientific community be in the shaping of those structures?

Despite the advances in the means of communication, people nowadays have essentially no choice but to come in contact with technological knowledge -useful to their everyday lives- almost exclusively through consumer products, a model which, we believe, increasingly widens the gap between the use of products of technology and the actual technological knowledge. In that context, one question arises: Is the scientific community ready to dissolve the obscurantist barriers still dividing people into 'Intelligentsia' and 'the masses', barriers preventing non-scientist members of societies from becoming active communicants of technological knowledge, pushing them, instead, into a consumerist way of interacting with material goods? Are we ready to shift from a consumer society to a thinker and maker society, at least as far as our immediate surroundings and manipulation of matter are concerned?

Another question raised by this paper is that of interdisciplinary collaboration, regarding aspects such as its potential and its feasibility. In which ways would diverse scientific communities come in touch, collaborate effectively and develop a rich collective intelligence pool, in an effort to interweave global knowledge that still remains scattered and isolated across different disciplines and loci? One can see great potential and actual creative learning between scientists, engineers, designers and craftsmen through this cross-pollination process, a process which, we believe, would greatly enrich each respective field by opening up new perspectives and revealing new, undiscovered points of view through the interdisciplinary exploration of both explicit and tacit knowledge.

Through the demand for widespread and uninhibited propagation of technological knowledge, a paradigm shift is envisioned. The rapidly advancing 3d printing technology in combination with the open-source movements around the world seem very promising, in that regard. Decentralized, collaborative structures of knowledge propagation are constantly emerging and computational tools are making it easier, day

by day, to understand and experiment with the behavior of matter. The question is: Is it possible these emerging technologies, to be fruitfully combined so that one day individuals regain control of the tools and more significantly, the knowledge to effectively and efficiently manipulate the matter that constitutes their immediate environment, their everyday objects, their artificial habitat?

5. Conclusion

In an era when knowledge, information and communication develop in virtual spaces, our paper considered the role that matter has in today's digital reality. Examining the propagation of knowledge, information and communication regarding crafting among communities of the past, we realized that matter manipulation had always followed the kind of knowledge and the communication tools of its era. Focusing on 'intelligent' crafting environments of the past, our investigation noticed that the 'intelligence' among those communities consisted of the role of the user during the design process; a nowadays -due to intense industrialization- rather lost one. Aiming to the development of intelligence in contemporary computational design and production environments, our attempt was oriented towards the conception of a model that would embed collaborative interdisciplinary research, emerging technologies in matter simulation and digital manufacturing as well as human action and intuition into the design process. Digitally simulating the complex behaviors and properties of matter through a user-friendly, real-time computer interface, our model aims to educate and assist users in the creation and manipulation of their personal -optimized to their local conditions and personal needs- designs. To close with a step for the future, we suggest this environment as a way to open a discussion about ecologic, economic and sociological-conscious design through users' learning.

References

- [1] W. J. Mitchell, *City Of Bits*, MIT press, Cambridge, 1996.
- [2] J. Ball, *Content-Rich Modernist Architecture*, 2010, (online) available at http://www.academia.edu/211276/Research_Question_Content-Rich_Modernist_Architecture
- [3] A. Tzonis, *Aspects of Mechanization in design: the rise, evolution and impact of mechanics in architecture*, Dept. of Architecture, Graduate School of Design, Harvard University, 1980.
- [4] R. Sennett, *The Craftsman*, Yale University Press, 2008.
- [5] S. Papert, *An Exploration in the Space of Mathematics Educations*, 1996, (online) available at <http://www.papert.org/articles/AnExplorationintheSpaceofMathematicsEducations.html>
- [6] M. DeLanda, *Material Complexity*, 2004. In: Neil Leach, David Turnbull, Chris Williams, *Digital Tectonics*, WILEY-ACADEMY, UK, 2004.
- [7] Intelligent Environments f(or) Creative Learning Call for papers, 2013 (online) available at <http://iecl.org/>
- [8] M. Polanyi, *The Tacit Dimension*, University Of Chicago Press, Chicago, 1967.
- [9] D. Piker, Kangaroo: Form Finding With Computational Physics, 2013, *Architectural Design: Computation Works: The Building of Algorithmic Thought* 83 (2).
- [10] N. Negroponte, *Soft Architecture Machines*, MIT press, Cambridge, 1975.
- [11] M. DeLanda, *Philosophy and Simulation: The Emergence of Synthetic Reason*, Continuum, London, 2011
- [12] D. Massey, *A Global Sense of Place*, 1994, (online) available at <http://www.unc.edu/courses/2006spring/geog/021/001/massey.pdf>

Restructuring Beginning Design Curriculums with Visual Calculation

Derek HAM^{a,1}

^a*Massachusetts Institute of Technology School of Architecture & Planning, Cambridge, MA*

Abstract. This paper takes a look at the design studio, its practices, pedagogies and myths, and presents computational design methods through shape grammars as a solution for improving its overall effectiveness as a learning environment.

Keywords. design studio, shape grammars, creativity, play and learning

Introduction

This paper presents an argument for situating shape grammars as the core component of beginning design curriculums. By doing so it heightens the importance of visual calculation and algorithmic thinking as skills necessary for 21st century professionals. Architecture and design education has evolved gradually over the last one hundred years with only slight adjustments to its practices and pedagogy. In fact, the educational philosophy of the design studio is rarely made explicit. Most literature on architecture and design education focuses on “what” is taught with little emphasis on the educational theory that justifies its effectiveness as a mechanism to learn design. Because of the scarcity of this inquiry, the educational philosophies of many design curriculums are full of inconsistencies and have shortcomings as a learning environment. Unlike architecture, the field of education is constantly offering new knowledge on how individuals learn and how instructors facilitate learning. This places design education at a crossroad, for those in the practice of teaching must be knowledgeable in the design discipline and equally knowledgeable on the ways individuals learn.

Historically the “design experience” was not given to students at the beginning of their academic career. The German Polytechnic model of design education, from which the early American architecture programs were modeled on, placed heavy emphasis on studying math, physics, and technical drawing in the early years of the curriculum. A full year of design did not come until the fifth year of study [1] [2]. By the early 1900’s the Beaux-Arts traditions of design education began to replace the older polytechnic model and introduced design projects in the very first year of study. In the 1930’s this curriculum would merge with another strong influence on American design education, the Bauhaus. The Bauhaus kept the Beaux-Arts traditions of studio based projects but with it introduced the concept of “Basic Design” as the focus of study for the student’s first few years.

¹ Derek Ham: PhD Candidate, Massachusetts Institute of Technology School of Architecture and Planning, Cambridge, MA 02142, dham@mit.edu.

The Basic Design curriculum can be understood from two opposing educational perspectives. The overtly abstract nature of projects, without function or practical usage, could be negatively seen as the “export paradigm.” David Perkins in his forward to the book *Studio Thinking* points out that students are often forced to learn things that are only applied and used for some hypothetical future [3]. On the other hand, the Basic Design curriculum can be seen as a form of “scaffolding” information for the learners [4]. In many ways the Basic Design studio with all of its abstraction is helping bridge the gap from design novice to design professional. However, there are still many misconceptions on how individuals learn and how creativity is fostered that hinders the effectiveness of design studio learning environments.

1. Design Studio: Pedagogy and Myths

1.1. The Myth of the All-Knowing Expert

Students are constantly working under a timeline set by the studio professor in which they have dedicated moments where they must explain their work. These moments of discussion and inquiry are called “design crits.” This interaction takes place most commonly between the design instructor and the design student. Donald Schön in *The Reflective Practitioner* illustrates this scenario with the fictional characters Quist and Petra to depict the faculty- student relationship [5].

The instructor’s role in the design studio presents much contradiction in the design studio’s *espoused theory* of practice and the *theory-in-use*. On one hand the design studio is said to be a *constructivist* learning environment where the end solution is never in sight and the design students learn through inquiry [3]. Some who espouse this theory even boast that design is something that cannot be taught [6] [7]. Other perspectives of the design studio show an *objectivist* learning model at work, where knowledge on design is transmitted from instructor to student [7] [8].

In the design studio, these two educational philosophies are always in tension; in some cases they are both active, existing in contradiction. Ellen Langer talks about the top-down vs. “bottom-up” approaches to teaching in *The Power of Mindful Learning* [8]. Top-down approaches, “*relies on discourse, lecturing to students,*” and would be what she calls “*mindlessness*” [8]. The alternative path in what she calls “*mindfulness*” is the “bottom-up” approach which follows along the experiential methodology of learning as championed by Bruner, Dewey, Rogers, Montessori, and Gropius to name a few. The Bauhaus model of the design studio clearly recognized that design was not something that could be taught “top-down”.

Although the Bauhaus was great for solidifying constructivism in the design studio, it also carries much of the blame for the seeds of objectivism we see prevalent in the architecture studio today. Students often expect from their instructors explicit direction and design knowledge. The attention paid to “star designers”, and the re-embodiment of the guild system with its master-apprentice relationships were all instituted by the Bauhaus and can still be seen in the studio today [1]. Design juries, a tradition stemming from both the Beaux Arts and Bauhaus, personifies objectivism. Students look to these perceived outside “experts” for confirmation and assessment of their design decisions. Schön’s example of Quist the studio professor and Petra the design student highlights this scenario with Petra learning by watching her instructor “re-frame” the design problem through a series of dialogue and sketching [5].

However, Schön tries to break the instructor away from the image of the “master” to that of the “coach.” In *Educating the Reflective Practitioner* Schön points out good coaches are constantly trying to discern what the student understands while students are trying to decipher what the coach is trying to demonstrate and describe [9]. Several learning theories might suggest that the coaching goes too far in the design studio. Schön points out that one common mode of knowledge transfer in the studio is demonstrating and imitating. Coaches demonstrate and the student imitates. In this process the imitator has to both observe and reconstruct. Whether or not this is an effective teaching strategy truly depends on the student. The student can either mindlessly copy, falling into automated - rote behavior, or the very act of copying can lead the student to see the project in a new way George Stiny recognizes that copying done mindfully is a key component in being creative[5]. “*Creativity takes recursion and embedding. Embedding let me copy without copying by rote – there are no building blocks – in a kind of visual improvisation that’s full of surprises. Anything can change anytime*” [10].

1.2. The Myth of Creative Individuality

Some would make the case that the design studio is a vibrant hub of collaboration and group learning. In fact, it is true that a big component of the students design process comes in the form of dialogue about their work. However, just because the studio is structured in way in which students are working in small groups does not mean the students will automatically engage in peer-to-peer learning [11]. In fact Hackman calls this phenomenon “co-acting groups,” where members are working in proximity to each other with the same supervisor but each have individual projects [12]. Another sign of these co-acting groups not being “real teams” is the absence of co-dependence, in which the individual’s job completion does not depend on the actions of the other members.

In a recent ethnographic study completed in the spring of 2012, I documented the learning environment of a third year architectural studio at MIT’s School of Architecture. There were very few instances in which I observed all of the members of the studio working in one environment at the same time. There was always an overlap between those who worked in the studio, those who were busy in other classes, or those who chose to work from home. When students were in the studio, many worked with headphones on and almost everyone worked in silence. When the silence was broken, conversations usually generated around operational information, such as specific questions around the schedule of the class. This image shows a striking divergence from that of the ideal collaborative design studio.

Part of the reason for the design studio’s misguided educational philosophy, *that design is best learned individually*, comes from the profession’s perspective on creativity and originality [1] [13] [14]. Lawson writes, “*We have come, rather falsely, to associate creativity with originality, so it follows that designers selling their skill want to seem original in as many ways as possible*” [14]. Prior to the enlightenment, creativity was seen differently as artisans worked in collaborative teams under one guild. Singer documents, “*The artist worked in teams-on the cathedrals, for instance – and did not believe they were hired to display their individual being through creativity. The church ordained the style as well as the content of what was to be expressed and the artist was required to submit to ecclesiastical authorities in almost every detail*”[15].

When the guild systems collapsed formal educational systems gave a new sense of purpose for the artisan and the designer. Johan Huizinga speaks of this shift in *Homo Ludens*, "...the main task of the architect was no longer in the building of churches and palaces but of dwelling houses; not in splendid galleries but in drawing-rooms and bed-rooms. Art became more intimate, but also more isolated; it became an affair of the individual and his taste" [16]. Hence came the birth of the arts as an expression of individual talent and along with it the folk lore of the savant, the original, and the creative genius.

The myth of the talented design student as a genius working in solitude is in stark contradiction to prevailing educational theories on both learning and on creativity. Fisher suggest that if architecture is to align itself with the arts then it should do so by modeling itself after the performing arts and less like the visual arts [1]. "*Collaboration is the art of design,*" he states. While visual arts promote the notion of individual creation it is the performing arts that, "*offer a model of inherently interdisciplinary, collaborative art form*" [1]. The design studio will never truly become a collaborative learning environment until it shakes the perspective of creativity being linked with individual talent.

2. Teaching Design through Shape Grammars

In this next session we shift away from the design studios current pedagogy and practices to focus on a viable solution to teaching and understanding design. If the before mentioned methods of going about design education are flawed, how aught we go about teaching design? A fresh approach to design instruction is to present design as a form of calculation. With every action of the design process we are indeed calculating. There is calculating for firmness, calculating for commodity, even calculating for delight. The ways in which we go about calculating defines the process of design and should be the very focus of instruction within design education. However, teaching with a pedagogical stance that gives formal explanation to what has previously been considered unquantifiable comes with much criticism. Those who identify themselves with the business of traditional calculation (mathematicians, logicians, computer scientist) perceive design and the arts as subjective, and irrational. Designers, architects, and artist perceive design methods that embody calculation methods as limiting, lacking emotion, automatic, and a hindrance to "creative expression."

For designers to embrace design as a form of calculation they must gain new understanding on what it means to calculate. In a 2010 paper titled "What Rules Should I Use?" Stiny addresses the title question with a short but precise answer, "*Use any rule(s) you want, whenever you want to.*" An answer that demands personal human input is far from the assumptions many presume about computational methods of design. While some researchers are looking for "rhino scripts" and one click solutions to produce artificial creativity, shape grammars relies on the human eye to guide the design process. Shape grammars do not tell you why you should use any particular rule, what rules to use, or even what sequence to use them. It does however, present a way to calculate, a way to design and talk about design, and a way to think reflectively about what you are doing for inspiration to move forward. Through recursion and embedding, shape grammars are the gateway to creativity.

Shape grammars, a form of visual calculation, provide the unifying arrangement that situates design between being an intuitive artistic expression and being a formal

system of calculation. Shape grammars with its schemas and rules provide both algebraic and graphic blueprints that can be descriptive and/or generative in use. When applied, shape grammars are not fixed, but flexible, allowing for emergence as new shapes and rules can be introduced at any time effortlessly. Embedding and recursion provides a fluid, intuitive way of designing that is invigorating and illuminates the “play element” in the design process.

2.1. Playing to Learn

The importance of “Play” in the design studio relies heavily on its ability to bring forth creativity. In fact it is impossible not to be creative while in state of play. Singer states, “...play and playfulness must be understood as essential elements in creativity as a whole”[15]. We can safely summarize that play and creativity has a strong correlation.

Play = Creativity

At the same time, we have already summarized that creativity contains recursion and embedding [17]. As shape grammars have shown us, recursion and embedding is copying with a purpose. We can then state that,

Recursion + Embedding = Copying

And also,

Copying = Creativity

If this is true then by definition copying is in fact being in a state of play and a state of creativity all the same.

Copying = Playing

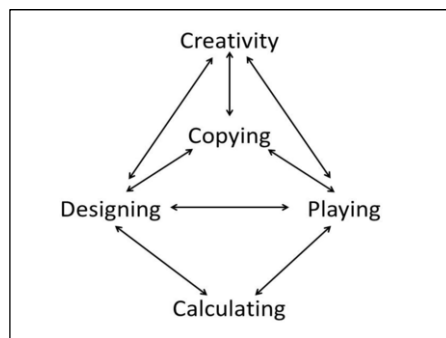

Figure 1. Creativity Diagram

It is easy to see that when one is copying they are indeed in the “ludic state”, a state of play. As Stiny states, “*Embedding lets me copy without copying by rote – there are no building blocks – in a kind of visual improvisation that’s full of surprises. Anything can change anytime*”[10]. What allows Shape Grammars to be such a strong

agent of play is its requirement for the designer/game-player to constantly use their eyes. It's a game of seeing.

In his book *Homo Ludens a Study of the Play-Element in Culture* Huizinga refers to the phenomena of play and play space as the "magic circle" [16]. The magic circle transcends the player(s) into a mode of thinking and behaving that allows them to behave differently than if outside this "temporary world described by play." Within the magic circle a broom can become a horse, a stick can be a sword, and people are in a heightened state of imagination and creativity.

There are multiple dimensions to being in a state of play, each with different affordances. The earliest stage of play can be thought as "free" or open play. Within visual calculation this is played out by a complete openness and freedom to see, create, and change at any moment. However, when one subjects themselves to a specific grammar system defined by a discreet set of rules, play evolves into "gameplay." Games are special instances of play that are formulized and bound by a set of rules [18]. Games evolve out of playful activities and in turn set the conditions for a new type of play; in doing so, they require focused creativity from the player.

An example of this type of ludic activity through Shape Grammars can be seen in the *Kindergarten Grammars* developed by Stiny [19]. The kindergarten grammars are an extension to the Froebel building gifts made popular by architects such as Frank Lloyd Wright. Within this system, shape grammars work with a kit of parts that serve as the vocabulary, and a system of configurations that together make the language of the design [19]. Just as in all gameplay, it is the constraints of the system that brings forth the play element and with it creativity. While the kindergarten grammars are combinatory in nature, they represent just one instance of the ludic offerings of shape grammars. When shape grammars go beyond combinatory systems, we can go beyond "0" dimensional elements to allow for more "play moves" that include embedding and shape emergence.

2.2. Shape Grammars in the studio

A pre-shape-grammar version of the kindergarten grammars have been used in the design studio sense the early days of the Bauhaus. The "nine-square" design project is a common exercise given to students in the Beginning Design curriculum. Within this exercise students are forced to work in complete abstractions. Love writes "By reducing possible design solutions to reductive elements like "walls-as planes" and "piers," students were encouraged to think about spatial relations"[20]. Unlike shape grammar's explicit usage of rules and vocabulary, these design exercises focus solely on the kit of part's pieces and configurations.

This can be problematic for several reasons. While this exercise does provide students with a scaffold introduction to thinking about form and space, there is no guide to lead students on what to do. Students are playing a game without knowing what moves they can take. Terry Knight points out, "Artist and architects do invent and play abstract design games, and one of the challenges of understanding styles and their evolution is confronting and understanding the rules of these games" [21]. They see the chess pieces before them but haven't a clue on the different possible actions. Of course the shape grammarian has an answer to this, "Copy!" Evidence supports that copying is what most students end up doing if not from their peers (secretly), from examples put forth by their studio instructor. If shape grammars could take a more

prominent role in the design studio then copying would be both practiced and celebrated as a creative playful activity.

A fresh approach to the nine-square design projects is to see design as a “kit of moves or actions” instead of seeing it as a kit of parts. Traditional nine-square projects present the design task as an assemblage problem. In this approach design elements take on a “0” dimensional property. Each component in the kit of parts exercise is treated as a single discrete element. Pieces cannot fuse together nor can they be broken. There is no embedding and therefore no emergence of new shapes, as the pieces in the kit of parts represent the entire universe. While this is definitely a form of play it is only one instance of the offerings using shape grammars. If designers would like to play within the confines of “0” dimensionality they should do so knowingly and not with the illusion that they are working within an infinite set of parts.

Ideally, studio design exercises should allow students to play within the upper limits of “3” dimensional shapes to account for embedding, recursion, and the emergence of new shapes. Shape grammars begin to allow this by presenting a set of schemas that constitute the elements of play. Parts are no longer discreet as the eye allows any shape to become a piece of manipulation. Moving, rotating, scaling, and mirroring (to name a few) are now the design “moves” that the student is more aware of and begins to play with these actions to discover a much wider array of design inquiry.

2.3. Shape-Grammar-Play in the Design Studio

The benefits of enhancing play in the design studio through shaper grammars are several. One benefit worth mentioning is the way *Shape-Grammar-Gameplay* encourages designers to take risk. Games and play have a wonderful way of promoting risk taking when players are in the magic circle. Langer notes risk taking as being a key ingredient in being mindful. *“Ironically, although work may often be accomplished mindlessly, with a sense of certainty, play is almost always mindful. People take risks and involve themselves in their play. Imagine making play feel routine; it would not be playful. In play there is no reason not to take some risks. In fact, without risk, the pleasures of mastery would disappear”* [8].

Shape grammars promotes risk taking in its application through the security it provides for the player in knowing what moves they have made and what possible future moves they can make. Schemas and rules provide a great sense of direction in the design process and as a result encourage the designer to be more experimental as they have a clear formal explanation for their design moves and actions. When young designers have no system to inform course of action or method to reflect on previous actions they have a tendency to get lost. Design decisions then become random and students are left looking for sources of inspiration and validation for their decisions.

In the same way that *Shape-Grammar-Gameplay* encourages risk taking it also promotes divergent thinking. A key trait of creativity is for one to have the capacity to hold a multi-view perspective on any given situation [7] [8] [22]. When students are working on projects in the design studio there is a pattern of activity in which they look at the design problem, imagine alternative solutions, implement changes, only to see new problems arise. Schön calls this the *“reflective conversation with the situation.”* Schön also notes that the experienced designer has the ability to “reframe” the design question [5]. He illustrates this in his narrative about Quist - the design professor, and Petra – the design student. In Schön’s example Quist has the ability to help his student

who is stuck on a specific design problem. Instead of continuing to wrestle with the problem Quist decides to see the problem from a new perspective, thus reframing the question to demand a new set of actions [5]. Eisner refers to this same phenomena as *flexible purposing*, “...the ability to shift direction, even to redefine one’s aims when better options emerge in the course of one’s work” [7].

Shape grammars are all about flexible purposing. Embedding is generous; it allows you to see whatever you want to see. While schemas give suggestions on ways to see a particular design they do not lock you into seeing things in any fixed way. This makes calculating a natural form of visual play. When you look around you see new things all the time; your eyes trace, flip, and manipulate shapes on a page unlike the discrete Newtonian way of seeing that our computers do. Shape-Grammar-Gameplay requires “multi-vision” to play the game successfully; the more ways you see, the further you advance in gameplay.

Finally, Shape Grammar Gameplay encourages collaboration in the design studio. A flaw in the current practices of the design studio is the individualization in the completion of creative design task. In short, students do not play together. On the surface there does seem to be collaborative efforts, but these exercises are usually on non-creative task. As pointed out in the AIAS 2006 Studio Culture Task Force, “*Group projects are most often limited to pre-design activities of research, analysis, and site documentation. The synthetic processes of design, in which negotiation and collaborative skills are most critical and difficult, are limited to individual efforts*” [23].

Shape Grammar Gameplay’s embrace of the practice of copying would remedy the individualized nature of traditional design studios. In current times it is taboo to “copy” a colleague’s work, but as we have already proven, copying is both being creative and playful all in the same. Many of the reasons students do not collaborate is a fear that a peer might “steal” their ideas [24]. In Shape Grammar Gameplay “stealing” is the name of the game. Students would be encouraged to share and copy from each other design rules and schemas. Embedding and recursion would occur to extend the individual’s drafting table to every table in the entire school. As the culture of mindful copying would increase, so would creativity.

3. Conclusion: Towards a Better Tomorrow

For long the design studio has struggled with teaching individuals how to be creative. Over the years creativity has been defined as being purely intuitive and somewhat mystical; yet, creativity is clearly expected from every student in showing mastery of design skills. This presents a problem for the design student, for they are tirelessly pursuing something that no one defines for them or tells them how to learn it. Donald Schön contest to this struggle in what he calls the paradox of learning new competencies. “*The paradox of learning a really new competence is this: that a student cannot first understand what he needs to learn, can learn it only by educating himself, and can educate himself only by beginning to do what he does not yet understand*” [5].

While it seems ambiguous to define creativity, educators and students alike seem keen on recognizing the byproducts of creative decisions. In truth individuals are more comfortable in identifying when someone is being creative than to give formal instructions on how to reach that “creative zone.” There is a growing concept in the field of education called *Make Learning Visible*. The theory states that if educators can make visible what it is their students are learning than they could be more effective by

adjusting the learning experience to properly match the student's level of development [25]. If learning is in fact invisible then there is no way to tell if students are more advanced or further behind the necessary place to understand the desired material.

There are striking differences between communities of Science, Technology, Engineering, and Math and the guild communities of architecture. While the STEM fields pride themselves with the creation and sharing of knowledge, design education's guild-like behaviors continue to promote secrecy and illusion to mask the true identity of acts we call "creative." Design education has been making learning invisible when it comes to offering information on how to be more creative.

A formal description of creativity would better guide students for future design experiences. This way of design should be generative and descriptive, allowing students to reflect on their actions and use their actions to move forward in the design process. Christopher Alexander tried to introduce formal systems of inquiry with little success [13]. His system was combinatory and rigid. In the future we can look towards shape grammars as a more flexible system that bridges formal explanation with the freedom of creative intuition [17].

References

- [1] Fisher, Thomas. *In the Scheme of Things: Alternative Thinking on the Practice of Architecture*. Minneapolis: University of Minnesota, 2000.
- [2] Ockman, Joan, and Rebecca Williamson. *Architecture School: Three Centuries of Educating Architects in North America*. Cambridge, MA: MIT, 2012.
- [3] Hetland, Lois. *Studio Thinking: The Real Benefits of Visual Arts Education*. New York: Teachers College, 2007.
- [4] Vygotskii, L. S., and Michael Cole. *Mind in Society: The Development of Higher Psychological Processes*. Cambridge: Harvard UP, 1978.
- [5] Schön, Donald A. *The Reflective Practitioner: How Professionals Think in Action*. New York: Basic, 1983.
- [6] Allsopp, Bruce. *Art and the Nature of Architecture*. London: Pitman, 1952.
- [7] Eisner, Elliot W. *The Arts and the Creation of Mind*. New Haven: Yale UP, 2002.
- [8] Langer, Ellen J. *The Power of Mindful Learning*. Reading, MA: Addison-Wesley, 1997.
- [9] Schön, Donald A. *Educating the Reflective Practitioner: Toward a New Design for Teaching and Learning in the Professions*. San Francisco: Jossey-Bass, 1987.
- [10] Stiny, George. "What Rule(s) Should I Use?." Presented at Nexus 2010: Relationships Between Architecture and Mathematics, Porto, (2010) 13-15.
- [11] Webb, N. M., & Palincsar, A. S. Group Processes In the Classroom. In D. Berliner & R. Calfee (Eds.), *Handbook of Educational Psychology* 3rd ed. (1996), 841-873.
- [12] Hackman, J. R. (2002). A Real Team. In J. R. Hackman (Ed.), *Leading Teams: Setting the Stage for Great Performances* (pp. 37-60). Boston, MA: Harvard Business School Press.
- [13] Alexander, Christopher. *Notes on the Synthesis of Form*. Cambridge: Harvard UP, 1964.
- [14] Lawson, Bryan. *What Designers Know*. Oxford [etc: Elsevier, 2004
- [15] Singer, Irving. *Modes of Creativity* Cambridge, MA: MIT, 2011.
- [16] Huizinga, Johan. *Homo Ludens: A Study of the Play-element in Culture*. Boston: Beacon, 1955.
- [17] Stiny, George. *Shape: Talking about Seeing and Doing*. Cambridge, MA: MIT, 2006.
- [18] Salen, Katie, and Eric Zimmerman. *Rules of Play: Game Design Fundamentals*. Cambridge, MA: MIT, 2003.
- [19] Stiny, G. "Kindergarten Grammars: Designing with Froebel's Building Gifts." *Environment and Planning B: Planning and Design* 7.4 (1980): 409-62.
- [20] Love, Timothy. "Kit-of-Parts Conceptualism," *Harvard Design Magazine*, Cambridge, MA: 2003.
- [21] Knight, Terry Weissman. *Transformations in Design: A Formal Approach to Stylistic Change and Innovation in the Visual Arts*. Cambridge: Cambridge UP, 1994.
- [22] Perkins, David N. *The Mind's Best Work*. Cambridge, MA: Harvard UP, 1981.
- [23] Dutton, T., Koch, A., Schwennsen, K., and Smith, D. *ALIAS Studio Task Force*. 2002.

- [24] Shih, S., T. Hu, and C. Chen. "A Game Theory-based Approach to the Analysis of Cooperative Learning in Design Studios." *Design Studies* 27.6 (2006): 711-22.
- [25] Newton, Douglas P. *Teaching for Understanding: What It Is and How to Do It*. London: Routledge/Falmer, 2000.

Something about craft

Guillermo BERNAL

Massachusetts Institute of Technology

Pratt Institute

Abstract. The objective of this experimental study is to explore the translation of Craft to Digital Craft. This research, while early in its investigation, seeks to explore architecture and digital design as a material process. The direct connection to output devices such as computer-numerically controlled routers, 3d printers and embedded electronics provide a unique opportunity for controlled variation and serial differentiation and seeks to exploit mass customization rather than standardization. Through a series of studies the process from design to machine file to finish product is explored. This connection to digitally driven fabrication equipment creates within the design process an opportunity to realize one's designs both digitally and material

Keywords. Digital, Fabrication, Craft

Introduction

This paper is a self-examination of the understanding of the word craft in the context of machine and computer technology. Digital fabrication and design computation now provide a new paradigm for the word "craft." New practices of architecture are seeking to collaborate in an interdisciplinary team, such as engineers, computer scientists and fabricators returning again to an interest in making. The potential for new avenues of collaboration and renewed interest in materials are challenging the role of the architect once removed from the building process. The translation from digital data into analog processes allows us to rethink the use of computer aided design as an instrument focused on the process of making.

Before we dive any deeper, what is Craft and why the term Digital Craft?

The term 'Craft' is defined and interpreted in a variety of different ways. Contemporary crafts is about creating objects. It is a cerebral and physical action where the makers explore infinite possibilities of materials and processes to produce unique objects. According to Dr. Nicholas Houghton, Craft is the development of practical, aesthetic and thinking skills and of creativity through the conception and production of individual works and an in-depth engagement with materials [1].

This 'in-depth engagement with materials' is commonly thought to mean one's physical interaction with materials; a millworker milling wood or a metalworker welding steel, but I am arguing that an engagement with materials can occur through other sensory experiences.

The designer, craftsman and writer David Pye, set out to answer the question ‘Is anything done by hand?’ revealed to us how we might have the wrong idea of the meaning of the word Craft [2]. He argues that very few things are made or can be made by hand. The activity we call Craft does not, he said mean ‘made by hand.’ Most things made by craftworkers require tools, and some of these tools are elaborate, time-saving machines [3]. This research seeks to explore the relationship afforded to today’s designers as information technology redefines “*Craft*” into “*Digital Craft*”. Machinery not only allows us to save time, but it can also push materials past the point of human capacity, opening up new characteristics and behaviors that may not have been previously explored. The reality of the physical constraints of the material world, its self-organization, and structuring mean that there are limits to what is indeed possible through human interaction, but new and developing technology broaden our scope of what is possible and what is impossible.

1. Material as a medium

The first area in which Craft can be explored is the setup and assembly of a project. Every project has different needs and restrictions and “understanding affordances and constraints is exactly what engineers, designers, artists and craftspeople do well.” [6] Normally these steps are associated to Craft in the physical realm, but it is equally as important to put time and effort into Craft in the digital realm, or what I am calling Digital Craft.

CNC fabricated physical objects inherit the exploratory and informative function of its manually produced predecessors, but this is a double-edged sword in many cases. The final object can be utilitarian and soul-less, or inherit great character and manifest the exploratory processes that lead to its creation. The experience in physical models in the material world provides visual and sensual information, which can’t completely be substituted in virtual world. Tom Porter and Jean Neale (2000) [4] contemplate the idea that the senses of touch and smell also become a part of this observation. To this I would like to add hearing as well. Experimenting with this idea, the design of Exocarp (**Figure 1**) came about by separating the areas where the body would touch the chair and areas where an extrinsic agent might try to approach the chair. Thus, the areas that the user touches the chair became smooth and comfortable whereas the areas approached by an extrinsic agent became texturized using a script that uses a perlin noise algorithm to generate the irregular texture, where the script to generate the irregular texture increases in amplitude proportionate to the surface area.

Through the use of birch plywood, a secondary pattern emerged through the variation of grain (Figure 2). This pattern was not predicted and it was truly a wonderful surprise that can only be achieved with CNC machines. This type of investigation starts to give more of an understanding of material and craftsmanship, as opposed to simply generating an output from a file; by layering the material and paying close attention to detail, a more personal product can be achieved through digital means, as opposed to a generic and utilitarian form.

2. Interaction as a Medium

Manta is an interdisciplinary project that required expertise in architecture, fabrication (Seth Edwards, Guillermo Bernal), interactive technology (Eric Ameres), and acoustics



Figure 1. Exocarp chair. 3axis CNC milled.

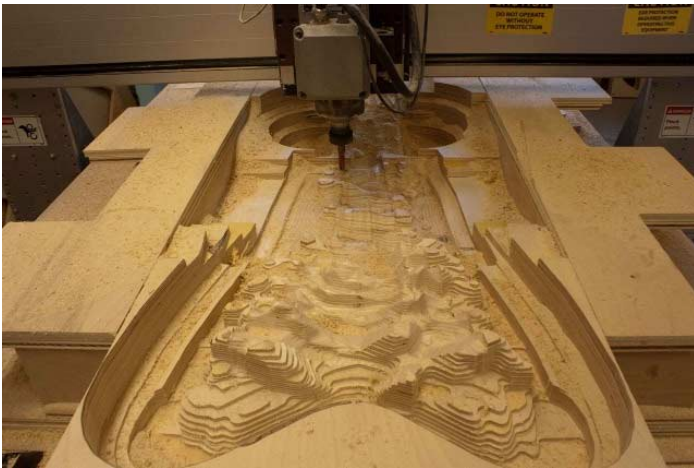

Figure 2. Exocarp Chair, 3 axis CNC milled.

(Zackery Belanger). This combination drove the assembly of the design team, who came together for the first time from disparate careers and backgrounds. The result could only be achieved with a holistic design approach: all team members worked together on all aspects of Manta. This type of design model might not be conceived as the ideal one as only a few design firms would work this way [5], however since the project was to be built and installed in only four days, every aspect had to be perfectly choreographed. From the point of initial shape conception, each area of expertise held equal weight in the decision making process.

Manta is composed of CNC machined panels and connectors of two thicknesses of high-density polyethylene (Figure 3). The curved forms resulted from a combination of triangulation and bending stiffness: geometry and material in concert. The result is a controlled morphing that is suspended at a minimum of points.



Figure 3. Manta, movements shown in long exposure image.

Drawing from a strong group of cluster participants, and with the support of Smartgeometry, Grimshaw Architects, and Rensselaer Polytechnic Institute's Experimental Media and Performing Arts Center, Manta is a surface that changes its form and therefore acoustic character in response to multimodal input including sound, stereoscopic vision, multi-touch, and brainwaves (Figure 4). While adaptable acoustics are common, Manta explores new levels of continuity and responsiveness, advancing acoustic systems beyond individual elements and corrective treatment

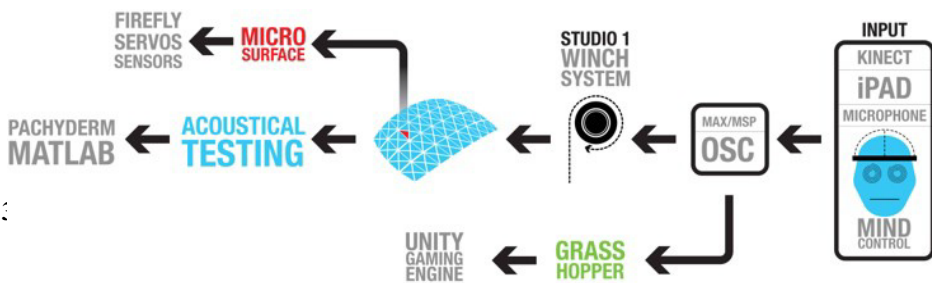

Figure 4. Manta, system flow acoustic simulation.

Digital composites are comprised of a small number of types of discrete physical components, which assemble to form constructions that meet the versatility of digital

computation and communication systems. This project questions how and what would it mean to make objects that can respond to their environment.

The integration of flexible polymers and electronics components is what makes this a digital composite. This exploration is done by making an object using multiple fabrication methods, from analog to digital and back to analog. In this case, the object is an artificial jellyfish virtually generated by coding using a recursive algorithm in Rhino Python. The 3d file is later broken down to generate a positive 3d print that later will be used to make a mold. One set of 3d prints is sufficient to cast the 8 part molds. Once the mold is ready, the custom circuits that include LEDs and small DC vibrating motors, among other components, are inserted into the mold and cast in silicone. A serial communication line is the method in which the ArtiJellyFish can be programmed to sense proximity and display its reaction to the person near it, by shaking and changing its light color from a warning red to a normal state blue or a friendly pink.

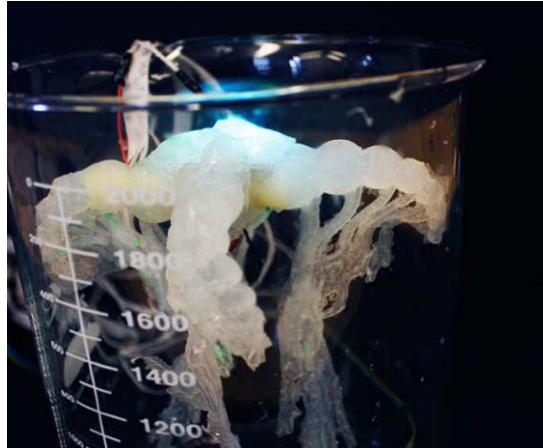

Figure 5 ArtiJellyFish, LEDs on, Sensors taking readings.

In this example, the “*Digital Craft*” is assigned to the fabrication process. I decided to explore this path since there seems to be a ubiquitous sense that the most common feature about technology is that everything begins to look the same. McCullough even states that “in the microstructure of the digital medium, arrangements and values can always be reconstructed [and] additional instances and versions can be replicated.” [6] In this case, technology is a key part of the process but its output is subject to the workmanship of the author, allowing room for exploration and changes in output; the creator must move past the microstructure and digital arrangements of data and start to input personal preference, therefore creating an individualized artifact. The ArtiJellyFish is not a finished product once the molds have been cast and the electronics are assembled; the maker must then program the output and harness the technology that has been embedded into the object. It is the work of the maker and programmer that truly defines form and personality of the product, therefore creating a need for human interaction in the material world.

Conclusion

There seems to be a deep urge to make things these days, with all the hype of 3d printers and its accessibility, it seems likely that making will endure the shine of the virtual world and its technology. For some people, the method of exploring ideas is the best path to understand those ideas. These early explorations have allowed me to begin to understand the translation from digital to analog and vice-versa, as well the limitations of materials and fabrication processes. Neri Oxman talks about how these new digital technologies manifest the ability to recreate and apply tools of and for materialization and techniques to not only do what their ancestors did, but also to provide a flexibility for custom fabrication which from the design perspective carries a lot of potential [7].

Digital tools have caused a new paradigm and with it, a desire for complex geometry and interactivity. This new paradigm brings with it the added responsibility of translating those designs into a material culture and the built environment. It is at this point that the role of digital fabrication needs to be extremely critical of itself, going back to early notions of Craft and material understanding. It is not Craft as “handcraft” that defines contemporary craftsmanship, it is craft as knowledge that empowers the maker to take charge of technology [1] (p.140).

References

- [1] DR Nicholas Houghton, Benefits to the Learner of 21st century Crafts, *Journal* 2005.
- [2] David Pye, *The Nature and Art of Workmanship*, Cambridge, Cambridge University Press 1968.
- [3] Peter Dorman, *The Culture of Craft*, Manchester University Press, Manchester and New York, 1968.
- [4] Tom Porter and John Neale, *Architectural Supermodels*, Architectural Press 2000.
- [5] Mary Godwyn, Jody Hoffer Gittel, *Sociology of Organizations: Structures and Relationships*, 2011
- [6] Malcolm McCullough, *Abstracting Craft: The Practiced Digital Hand*, London, England, MIT Press 1996.
- [7] Neri Oxman, *Digital Craft: Fabrication Based Design in the Age of Digital Production*, Ubicomp 2007

Designing Design Heuristics: The Creative Crowd

Yaniv TURGEMAN^{a,1}

^a*Massachusetts Institute of Technology*

Abstract. In order to generate a contemporary problematization of issues of creativity and learning culture within electrated intelligent environments, this paper focuses on a recent project of the MIT Senseable City Lab, the “Makr Shagr.” In the first part of the paper [Part I: The Experiment of Makr Shagr; co-Creation and Consumption In Search of Social Design Intelligence], I analyze the ideas that brought the project of Makr Shagr into being, and describe the actual platform of social co-creation. I discuss the design and function of the project, which is based on a platform providing access to anyone who desires to create an alcoholic or non-alcoholic drink, and describe the experience of the emancipation of drinking-culture from the hands of its experts to the hands of its customers. In the second part of the paper [Part II: Creative Learning Via Social Imprimers; Minksy’s Model of “Attachments-Goals” Learning Process,] I comment on how the project may serve toward the problematization of the construction of social platforms of co-creation and participatory design processes. I discuss the ideas emerging from the existence of the Makr Shagr project and expand to notions of creativity and culture, by focusing on the new positioning of the collective-amateur as expert, i.e. as the tool-holder and subject of creation, and on the formation of a new culture of “expanded base.” My question here is: What are the implications of a process in which everyone can contribute to the design and creation of a cultural product on the way we define the creative subject, as well as cultural value and significance. The salient idea in the paper is that in participatory environments of co-creation, the individual participates in processes of meaning-making through the construction of shared stories, and that this process provides the creative subject with social imprimers that help shape preferences and therefore gradually formulate the culture of the creative crowd.

Keywords. design democratization, bottom-up culture, third industrial revolution, co-creation, social design intelligence, social imprimers

1. Introduction

In this paper, I attempt a contemporary problematization of a fundamental issue of the Theory and Practice of Design and Technology that generated great controversy in the past and present century, dating back to the radical 1960’s: the democratization of tools

¹ turgeman@mit.edu
+1 (617) 955 7117

and processes of design and meaning-making. My vision is to problematize and expand notions of design democratization by examining how contemporary electrate [1] creative environments can provide a fertile setting for experimenting toward the emancipation of creative design processes from the hands of the few tool-holders and therefore influence the development of social design intelligence, and the enablement of bottom-up culture. I focus on the experiment of Makr Shakr, a recent project of the MIT Senseable City Lab, which aimed to the design and set-in-action of a robotic bar, operated by the instructions of its creative crowd; its customers. My main argument is that through our contemporary experimentations with intelligent environments we above all demonstrate a shift towards a new paradigm of acquiring knowledge and shaping culture; a new paradigm of creative learning at a social level.

2. Open Questions

The fundamental issue that overlies the theoretical contemplations and the description and analysis of the Makr Shakr project in this paper, is a question of how we address issues of participatory design [2] and creativity within the contemporary world of expanded information and technology. I am wondering how could our emerging electrate environments serve to problematize fundamental processes of design, production, and consumption, as well as how these processes reformulate the embedment of meaning, as we transition from the individual to the social level? Through the example of Makr Shakr, I extract the creative process within intelligent technologically-advanced environments as a process in which the subject itself becomes electrate and participates as co-inventor i.e. conceiving new processes, and co-creator i.e. controlling the tools and setting them into action for the purpose of a final product, in the formation of a creative crowd. This creative crowd possesses a common, social knowledge of a design process. In it, the role of each creative subject is redefined through its participation in the processes of design-for-final-product, while the creative process shifts from the individual to a participatory level.

In this paper, I name the distance between these two levels of creation, culture. I refer both to a new subject as the outcome of an emergent participatory culture of shared co-creation and to a new type of bottom-up culture resulting from the channeling of the individual creative resources and providing the setting within which those very resources function in a constant state of flux and evolution. On the one hand, a participatory culture in which everyone possesses the tools of meaning-making, and creates within intelligent environments that are programmed accordingly to the shared knowledge, results in the formation of a new type of creative electrate subject. On the other hand however, the final product of this new mentality toward creation contributes at the same time towards the formation and evolution of a new bottom-up co-shaped culture, which in its turn also functions in constant flux. I argue that the shift in the process of design, from conception to creation, as we transition from literacy to electracy, is accompanied by a slowly-formed process of redirecting human evolution, of augmenting our creative selves toward the formation and, at a posterior point, within the activity of a creative social crowd.

Therefore, I ask: *How do we as creative subjects shape culture and are simultaneously shaped by and within the emergent electrate culture of creation?*

3. The Experiment of Makr Shkr; co-Creation and Consumption in Search of Social Design Intelligence

In recent years, the Kuka robotic arm [3] has come to be a symbol of the Third Industrial Revolution, [4] the revolution of digital manufacturing; a mechanical and digital extension of the human arm, epitomizing our human existence as technologically advanced cyborgs. As with the advent of the pen, the development of the robotic arm has extended our boundaries of possibility, whilst raising increasing questions of the need for human participation at all. When man first picked up a pen and learned to write with his own hand, Socrates proclaimed the “death of wisdom” as we began to outsource our mind’s currency onto an external medium. Today we are witnessing a similar phenomenon, as we pass on the pen to our technological counterparts.

Researchers and engineers at MIT Senseable City Lab, Cambridge, in collaboration with The Coca-Cola Company and Bacardi rum, have designed the robotic bar, capable of preparing approximately one googol (10¹⁰⁰) crowd-sourced drink combinations. “Makr Shkr,” an experimental platform of social exchange of creative ideas for the construction of a participatory collaborative culture, was imagined in January 2013, and had its first public test mid-April, at the 2013 Milan Design Week. This exhibition was developed with the endorsement of “World Expo Milano 2015 – Energy for Life. Feeding the Planet”, and was a preview of the final prototype which was unveiled at Google I/O in San Francisco, on May 15, 2013. During these events [6], thousands of people experienced the opportunity to let their imagination conceive their own mixes of drinks, and have their cocktails made by three robotic Kuka arms, which were programmed with the preparation capabilities of a human bartender. The machines measured and controlled the consumption of alcohol that was accumulated in the creator-consumer’s blood accordingly.

The Makr Shkr was designed as an experiment on co-operation towards the creation of culture and is here used as an example of an attempt to enhance the development of a platform of social co-creation and observe the results of this creative cooperation in terms of culture and social interaction.

How does Makr Shkr work?

Users navigate to a web app on their handheld devices, where they have a choice of two entry points to drink creation: “customize a classic”, “start your own”, and “mix socially”. Customizing a classic recipe starts the user with a list of classic cocktails from which they can choose one to start from, or they can start on their own from scratch. Alternatively, a user can choose to explore the drinks created by other users. The user can filter subsets of drinks based on both ingredient-based and social-based parameters through the visual interface, and identify a drink and/or user of interest. On selecting a drink to explore, the user is presented with a listed genealogy of iterations for that drink, each entry includes the changes that user made, as well as a five parameter rating they gave their resulting mix. Additionally, each version of the drink in the genealogy shows the number of people who have tasted it and the average rating. With this insight, the user continues to the customization step, which is identical for all three entry points. Here the user has the opportunity to add and remove a variety of ingredients, adjust the proportions, and select actions for preparation (such as shake, blend, muddle, etc). Once the user verifies their cocktail’s prescription, the system

generates a name for the drink, editable by the user, and the drink is sent into the queue to be made.

The large seven meter screen serving as the backdrop for the robotic arms displays realtime visualization of the process. The visualization is divided into the three principle parts from left to right which make up the experience of user controlled digital manufacturing: design, make, and enjoy. Each area shows realtime insight about the ingredients, cocktails, and the people and groups of people making them. When the drink is ordered, it is represented in the queue on the left, along with realtime insights about the drinks being designed. As the drink reaches the top spots in the queue, the drink icon is enlarged to show more information about the ingredients and user. When the drink is ready to be made, the icon moves to the make section directly above the robots and a detailed process of the making of the drink is visualized, giving insights about the ingredients used.

The cocktail is crafted by three robotic arms who reproduce the actions of real bartenders. From the shaking of a Martini to the muddling of a Mojito, and even the thin slicing of a lemon garnish. Roberto Bolle, étoile dancer at La Scala in Milan and Principal Dancer with the American Ballet Theatre, along with Italian director and choreographer Marco Pelle, inspired the gestures of the robots. Roberto Bolle's movements were filmed and used as input for the programming of the Makr Shkr robots. The Kuka can move at over 10 times the speed of a bartender, with sub-millimeter accuracy, but what it gains in efficiency it risks losing in the very qualities of a bartender; presence. In this light, the movements of the arm have been designed to give it a distinctly caricatured behavior. While the nature of the experiment in no way suggests or explores the notions of replacing real bartenders in commercial bars, some theater was employed to engage the crowd.

Makr Shkr can mix both non-alcoholic and alcoholic drinks. The digital design system monitors alcohol consumption and blood alcohol levels by inputting basic physical data, something beyond what a traditional barman can do. Makr Shkr promotes responsible alcohol consumption by allowing people to self-monitor their drinking. A contribution is asked for drinks being produced by the Makr Shkr, with any gain generated from the project - after production costs - being donated to the Politecnico di Torino for a student fellowship on the Third Industrial Revolution.

This project is an experiment from the digital world asking people to step out and connect in a real human experience around the shared design of a drink, essentially what we aim to facilitate with our cocktails. In a bar where any drink is possible, the visitors are inspired to engage in the limitless possibilities offered by a mechanistic environment. The 'intelligence' of the automated bar is governed by a cybernetic approach involving human observation. The arm becomes everyone's arm. Not only does the tablet-delivered digital interface of the bar place both visitor and the Kuka in the same communication language, it provides a platform for crowd-sourcing. As visitors are given the possibility to design and order their own drinks, so does the bar create a semantic database of cocktails; an ever-growing, evolving menu of drinks based on experience, meaning, and human involvement, waiting for others to tap into it and continue creating. "The environment has to be created by the activity of life, and not inversely," argued Constant.

The Makr Shkr project examines how the implementation of digital technologies in the design and practical realization of multi-purpose, multi-content processes of user-friendly modes of material production radically change the interaction between the products and their users. The vision behind the very function of Makr Shkr was to

demonstrate a shift in process; the new paradigm that may be extracted from the specific implementation of digital technologies in the design and implementation of open processes of material production.

4. Creative Learning Via Social Imprimers; Minsky's Model of "Attachments-Goals" Learning Process

"Trial and error can teach us new ways to achieve the goals we already maintain.

Pride and Shame play special role in what we learn; they help us learn *ends* instead of *means*"

-- Marvin Minsky, *The Emotion Machine* [8]

Parallel to my deep conviction that the shift in the creative process is a radical transition from the individual to the social, in this section of the paper, I focus on an aspect of learning and creating within participatory intelligent environments: the recursive process of developing preferences and channeling them into the formation of a culture of the creative crowd. In order to describe the process of individual preference and crowd culture formation through the fundamental mechanisms of learning that we possess, I analyze Minsky's "attachments-goals" model of learning and focus on the role of the imprinters [9] on the evolution of the knowledge-acquiring process of the human subject. I focus on Minsky's seminal paper in order to extrapolate a model of how we learn and expand this model to a social broader level; how we socially learn.

In the "Emotion Machine," Minsky outlined the ways in which knowledge can be transmitted to an infant, either through learning by experience or learning in special ways accordingly to the reaction of our imprinters. He mentioned "learn by being told" and "trial and error," as processes which belong to the first category of learning and finally focused on the concepts of pride and shame. He described pride and shame as two complexes of emotions that may result in altering the goals themselves rather than the methods used by a child in his experience of the world. Minsky coined the term "attachment bond" to refer to a process in which we learn values in special ways that depend on the people to whom we are mostly "attached." Those people are referred to as imprinters. The imprinters dictate what is worth aiming for. They contribute in shaping new goals and canceling out others, that are experienced as inappropriate or redundant.

Going back to the electrated environments of creative digital platforms, *in what terms does the creative subject regard and enjoy the product of co-creation?*

During the two events in which Makr Shkr was set into action, it was very interesting to observe the divergent attitudes of the creators/consumers towards their product of design; from indecisiveness and preference to specific pre-conceived choices, to absolute enthusiasm and free-association. The first results became clearer after some time that the Makr Shkr was set in action. The creators gradually became more and more engaged into the process, after they received the feedback from their "collaborators." After participating in the process of designing and experiencing other people's iterations of one's own conceptions, the final product was the result of a collaborative process, in which the initial conception was enriched with multiple corrections until the ultimate creation.

It was also very interesting to observe newly-conceived drinks become “popular.” The more people participated in the alteration of an initial conception, the more this drink became desirable. It was a product of collaboration. Everyone felt part of the conception, and identified with the result. The cocktail was enriched with the narrative of the collaboration between its multiple creators; it became culture. The cocktails became social preferences, co-shaped by individual preferences and being finally reduced to cultural statement, in the context of an emerging culture within the creative crowd.

It can be said that our preferences are in general terms influenced by the functional aspects of an object and the social narrative. By participating and creating a story, not only do we discover what people like, but we can also create a preference. Makr Shagr demonstrated that when a creative subject is embedded in the story around the design and creation of a product, the subject’s preference is shifted, due to this engagement. During Google I/O, it became obvious that the subjects of creation redefined their preferences and the goal of their design through their participation in the story of the product of co-creation. More specifically, each subject would start with an initial preference that was associated with the attachment of the subject to primary imprimers. This initial preference was finally altered, after the construction of a social narrative around a cocktail that was co-conceived, co-altered and iterated, and co-stabilized as to please the taste of a multitude of individual preferences.

The drink that people initially ordered was not the drink they would choose again after the creative process took place on a “social” level. That was because the construction of a story out of which meaning derives had taken place. There was some kind of recursivity in the process of creation: the original preference was shaped by top-down culture transmission of what is valuable, through social and parental imprimers. By allowing the subject to be part of the creative process from inception, new imprimers came into being. But in this case, those imprimers were coming bottom-up in a more fluid and dynamic way, and the iteration took place more quickly. The imprimers emerged within a social process of exchange and co-creation.

In this section, I argued that when we are more invested in the process of creation, it gives meaning to us, we participate in the creation of the story and the meaning-making, and therefore creative participatory platforms not only alter the terms in which we participate in creation, but also a mental effect, altering the decisions, our desires and goals during the design process. Based on Minsky’s description of the imprimers’ role on learning, one can now see the environment of Makr Shagr as an example of creating a more fluid setting for social exchange of knowledge and culture.

5. Epilogue

When Jeremy Rifkin outlined the concept of a Third Industrial Revolution, not only did its rhetoric fuel a desire, but a necessity for its conception. Unlike the top-down power structures of foregone eras of steam and electricity, Third Industrial Revolution proposed a new model that would shift the landscape of power. The decentralization of global energy networks, combined with the democratization of manufacturing, promised to usher in a new era of industry, economic growth, and prosperity. Renewable energies combined with cost-effective manufacturing; industrial productivity meets efficient sustainability. Universal networks built on participation at a local level, re-empowering individuals and communities.

In this paper, I addressed the question of how creative subjects are shaped through the participation of the individual into participatory processes of creation and how a bottom-up culture emerges from the preferences of this emergent creative crowd. I inquired into the mental tools and discursive terms to address this new kind of bottom-up culture. Based on Minsky's model of learning, I focused on the concept of imprimers, and expanded the model to social learning and creation within intelligent environments. Through the example of "Makr Shkr," I problematized the cultural setting of interactive design environments and collaborative conceptual processes, from a cultural-theoretical perspective. Based on MIT Senseable City Lab's first experimentations with participatory design, social learning and bottom-up culture, I touched upon notions of social co-creation within electracy under the expectation to raise the issues of defining creative subjectivity and culture within new settings of designing for/from a new social and cultural reality; the reality of intelligent environments for creative learning. With the description of the construction of the Makr Shkr platform and the experience of the people who had the chance to conceive, create and consume within this highly advanced digital creative environment, I demonstrated that the engagement of the subject of consumption into the process of creation, on a collaborative participatory basis, gradually redirects the evolution of the individual's preferences and formulates a culture of social co-creation.

Among these concepts of creating within participatory environments of creation, I see the revival of an avant-gardist approach to design as what Moholy-Nagy would call "the human intervention in evolutionary processes." [10] Beyond issues of individual work and craftsmanship, what I see mostly and above all in these intelligent environments for creative learning, is a promise for a new kind of subject emerging from a participatory mentality to be gradually integrated within a creative crowd that has the power to redirect its own evolution through a process of shaping and constantly re-visioning its own culture.

Let us leave the question of what it means to be creative within contemporary digital environments open, and let us allow the Makr Shkr installation force us to critically reflect on our hopes and fears, as we ponder, cocktail in hand, our emerging role within increasingly user controlled, automated, mechanistic, conte(x/n)t-aware creative environments.

References

- [1] Professor of English and Media Studies at the University of Florida, Gregory L. Ulmer, focuses on contemporary cultural phenomena as manifestations of a civilizational shift in the apparatus (social machine) from literacy to electracy. He coined the term "electracy" which encompasses the broader cultural, institutional, pedagogical, and ideological implications inherent in the transition from a culture of print literacy to a culture saturated with electronic media. For Ulmer, electracy "is to digital media what literacy is to print." According to Ulmer, the shift is gradual, with many transitional features, but ultimately produces a new dimension of experience in every area of the lifeworld (technology, institutions, individual and collective identity behavior). Ulmer, G. L. *Internet Invention: From Literacy to Electracy*. New York: Longman, 2003
- [2] A quick google search demonstrates that the term participatory design is used in a variety of fields such as software design, urban design, architecture, landscape architecture, product design, sustainability, graphic design, planning or even medicine as "a way of creating environments that are more responsive and appropriate to their inhabitants' and users' cultural, emotional, spiritual and practical needs" (from Wikipedia.) In the context of this paper, the concept of participatory design is used to refer to the conception and realization of a new process and setting for the creation of a product that has effect in human life in social and cultural terms.

- [3] The robotic arm is one of Kuka's many solutions for factory automation. The industrial robots fabricated by the worldwide German producer are applied in a variety of areas, such as transport, food industry, construction industry, glass industry, foundry and forging industry, wood industry.
- [4] Rifkin, Jeremy, *The Third Industrial Revolution: How Lateral Power Is Transforming Energy, the Economy, and the World*. New York: Palgrave Macmillan, 2011.
- [5] Google I/O is an annual developer-focused conference held by Google in San Francisco, California. Google I/O features highly technical, in-depth sessions focused on building web, mobile, and enterprise applications with Google and open web technologies such as Android, Chrome, Chrome OS, Google APIs, Google Web Toolkit, App Engine, and more. Google I/O 2013 (May 15–17, 2013) was held at the Moscone Center, San Francisco. Announcements of updates for Android, Chrome OS, Google Chrome and other services were expected during the conference. "Google I/O 2013". Developers.google.com. Retrieved 2013-05-31.
- [6] Videos and information about the demonstration of Makr Shkr during the Milan Expo and Google I/O 2013, can be found at the following links:
www.makrshkr.com
www.gizmodo.com/drinks-on-with-the-worlds-biggest-baddest-bartending-508259499
www.cnn.com/2013/05/16/tech/innovation/robot-bartender-mit-google-makr-shkr/
www.bbc.co.uk/news/technology-22523822
www.huffingtonpost.com/2013/05/20/makr-shkr-bartending-robot_n_3307599.html
www.theatlantic.com/video/archive/2013/05/these-friendly-robots-would-like-to-mix-you-a-cocktail/275817/
www.robohub.org/robotic-bartender-assembles-personalized-drinks-monitors-alcohol-consumption-and-takes-social-mixing-to-a-whole-new-level/
- [7] Roberto Bolle (born March 26, 1975) is an Italian danseur. He is currently a principal dancer with American Ballet Theatre and also holds guest artist status with The Royal Ballet and La Scala Theatre Ballet, making regular appearances with both companies. Retrieved from Wikipedia on 06/01/2013.
- [8] Minsky, M., *The emotion machine : common-sense thinking, artificial intelligence, and the future of the human mind*, New York : Simon & Schuster, c2006.
- [9] In the chapter "Attachments and Goals" of the "Emotion Machine," Minsky coined the term *imprimer* to refer to "one of those persons to whom a child has become attached." whereas *imprinting* is "a special way to learn new values that works only when an *Imprimer* is present." It can be said that *Imprimer* is Minsky's term for "caregiver," whether this refers to a parent, or anyone else who plays that role and has an effect on the formation, maintenance and dismissal of goals on the part of the infant. *Ibid*.
- [10] Martin, R. *The organizational complex : architecture, media, and corporate space*, Cambridge, Mass.: MIT Press, 2003, p. 54.

This page intentionally left blank

1st International Workshop on Sociable Smart Cities (SSC'13)

Eleni Christopoulou (University of Patras, Greece)

Dimitrios Ringas (Ionian University, Greece)

John Garofalakis (University of Patras, Greece)

This page intentionally left blank

Introduction to the Proceedings of the Sociable Smart City 2013 Workshop

Cities are the people that inhabit them, their memories, stories, concerns and the culture that develops through their social interaction. All modern cities share the same infrastructure and offer similar facilities, still, each and every one has evolved a unique character, depicted in every neighborhood's architecture and monuments.

Urban computing allows people to interact with their cities in novel ways aiming to shape and decide the future of the city. The focus of this workshop is on the social and cultural aspects of the smart city. The goal of this workshop has been to define what is a "sociable smart city" and how this vision can be realized. Issues that we approached and questions that we tried to answer follow.

Standing from the points of view of an urban informatics researcher, a city planner, and a citizen how do we see a "sociable smart city". Cities around the world integrate novel ICT infrastructure in the city fabric, how does it enhance participation, wellbeing and sustainability. Digital technologies, ranging from telecommunication to social media, commonly mediate communication among people, how does this affect citizens' ability and motivation to act on collectively shared issues. City authorities, transportation agencies, research initiatives that embed sensors in cities, even citizens open up data that reveal shared issues, processes and patterns taking place in the urban space; how can this be exploited. Local knowledge, depicting the past or uncovering how a place works, is highly related to a temporal and spatial context, how can this be captured and shared, thus becoming collective. Further, how can a smart city assist citizens to develop a shared sense of belonging and responsibility. Are there processes that can assist regeneration of urban areas. Can urban computing, via enabling storytelling, game activities, learning processes and artistic installations, offer digital tools and media to connect people and their experiences with the city.

We have put together an interesting program of 9 papers approaching the *Sociable Smart City* concept from diverse routes. Contributions of this workshop propose tools and systems that alter people's experience with the urban place, follow methodologies to reveal city dynamics and aim to define the concept of *Sociable Smart City*. A group work session along with the invited keynote speech from Professor Timo Ojala, who presented his experience from the ubiquitous city of Oulu, Finland, offered attendees a valuable insight and triggered interesting discussions.

The workshop organizers deeply thank the Program Committee and attendees for their vivid participation.

Workshop Co-Chairs

Eleni Christopoulou, University of Patras, Greece, hristope@ceid.upatras.gr

Dimitrios Ringas, Ionian University, Greece, riggas@ionio.gr

John Garofalakis, University of Patras, Greece

Program Committee

Florian Alt, University of Stuttgart, Germany
Carlos Bento, University of Coimbra, Portugal
Francesco Calabrese, IBM Research, Ireland
Irene Celino, CEFRIEL – ICT Institute Politecnico di Milano, Italy
Ioannis Chatzigiannakis, CTI “Diophantus”, Greece
Konstantinos Chorianopoulos, Ionian University, Greece
Ivan Elhart, University of Lugano (USI), Switzerland
Felipe Gil-Castiñeira, University of Vigo, Spain
Vassilis Kostakos, University of Oulu, Finland
Cristina López Bravo, University of Vigo, Spain
Irene Mavrommati, Hellenic Open University, Greece
Nemanja Memarovic, University of Lugano (USI), Switzerland
Florian Michahelles, ETH Zurich, Switzerland
Konstantinos Oikonomou, Ionian University, Greece
Timo Ojala, University of Oulu, Finland
Santi Phithakkitnukoon, The Open University, United Kingdom
Anna Sachinopoulou, University of Oulu, Finland
Michail Stefanidakis, Ionian University, Greece
Yu Zheng, Microsoft Research Asia, China

A Proxemic Interactive Platform for Sociable Public Zones in the Smart City

JIN Huiliang¹, Bertrand DAVID, René CHALON

Université de Lyon, CNRS

École Centrale de Lyon, LIRIS, UMR5205. F-69134, Écully



Figure 1 Proxemic Platform (Left: hand cursor control, Middle: scroll by hand glide, Right: file migrator)

Abstract. Public Screens are widely used in modern cities in the fields of public transportation, commerce, education and advertising. They respond to users' inputs passively rather than spontaneously interacting with them. Therefore few screens are sociable. This situation has started to change with the progress of interaction technology. In this paper we present an application independent proxemic platform, which includes a sociable public screen together with a file migration toolkit. The sociable screen displays information according to user's distance, orientation, posture, location and identity. Moreover, via the toolkit we can exchange resources easily and safely between various ambient devices with the screen. The platform works as a public sociable medium connecting citizens and providing new opportunities for them to communicate with each other. We describe the platform application using a bus shelter scenario before demonstrating the usability of our work through user study.

Keywords. Proxemic interaction, Public Screen, Smart City, Mobile Interaction

Introduction

With the prospect of ubiquitous computing, more and more large public screens will be deployed in future smart cities. These screens are used to display information, to advertise, as well in many other domains closely related to daily life. Public screens will play a key role in the future smart city. Screens presently deployed in the city mostly take the form of an interactive digital appliance rather than a "sociable" object. They only display contents according to users' inputs, rather than proactively communicate with users. Researchers have produced some instructive works about public display, such as Timo Ojala et al. [20] who placed the public display in the wild for three years, and studied the use of public display in real word application. They proposed to explore the link between mobile phones and public screens, which is also the problem we try to respond to in this paper. In addition, in order to build sociable

¹ Corresponding Author: JIN Huiliang, Ecole Centrale de Lyon, 36 Avenue Guy de Collongue, 69134, Ecully, FRANCE. E-mail :huiliang.jin@ec-lyon.fr

public screens, we have studied the principles of proxemic interaction, which applies psychological terminology to human-computer interaction to study the interaction modality on a large screen. Saul Greenberg introduced proxemic interaction as a new kind of ubicomp [10]. He identified five key elements of proxemics: orientation, distance, motion, identity and location. And he described the indoor proxemic media player to explain this new interaction. Marquardt et al. presented a proximity toolkit, which supports rapid prototyping of proxemic interaction based on the Vicon motion tracking system and Kinect [16]. Compared with the indoor application, the public screen scenario is more promising. Proxemics has extended traditional plane interaction to space interaction by classifying different interactive zones in front of the screen, thus allowing it to discover and attract the user before he/she directly touches the screen. Along with the user's identity recognition, we could build a sociable public screen, which supports more diversified proactive interactions.

Furthermore, the screen is not isolated, but serves as a hotspot for info communication among various digital devices (tablets, smart phone and smart watch, etc.). Future public displays are individual nodes of an open display network, as Nigel Davies et al. [4] described. They envisaged that open public display networks will emerge as a new communication medium for the 21st century, and are open to applications and contents from many sources, including users' devices. Nowadays if someone wants to download the bus schedule from the screen installed in the bus shelter, he/she needs to take a picture or scan the QRcode by camera. This may be time consuming and not viable if the surrounding light is not appropriate for taking a picture. Assume we could just shake the phone in our pocket for the relevant contents to be downloaded to the phone automatically, without needing to take a picture.

Our aim is to build a sociable public screen which acts like a person. It recognizes people, "talks" with them, as well as accesses people's digital devices. Then we try to study the role of the interactive public screen in future social life. In this paper, we first describe a proxemic platform comprising a sociable public screen and a file migration toolkit. In the remainder of the paper, we first introduce some related works. Next we explain the deployment of the proxemic platform. We then describe the bus shelter scenario of the platform application against the background of the smart city. Finally we present the user study and analyze the results, before proposing the future work.

1. Related work

The goal of our work is to transform a normal projection screen into a proxemic interactive screen, along with the data exchange solution among ubiquitous devices. With this we study the effect of the public interactive screen on social life in the city.

Marquardt et al. proposed a system called GroupTogether which could detect proxemics of users and their devices. It infers the user's group relationship by their relative positions. Moreover, people could share and send files via tilt mobile devices to orient devices. They emphasized the effect of people's group relationship while multi-users interact with the large display. Related research is also presented in another paper by the same author [18]. Vogel et al. [12] studied the principles for designing an interactive ambient display: the screen supported various interactions in different proxemic zones. They discussed privacy issues as well. Ju et al. [15] introduced their work on an implicit interaction electronic whiteboard, which is deployed in a lab for collaborative work. They used the simple distance based interaction modality. Vogel

and Ju thought the large screen was isolated and did not consider communication between the screen and other devices. Belloti et al. compared human-human interaction with human-computer interaction in their paper, and proposed instructive questions for interaction research which are valuable for interaction design. Proxemic interaction could also be regarded as one application of HHI in the HCI domain. With respect to the public screen, Florian Alt et al. [9] studied the problems concerning advertising on public display networks. They underlined the importance of sensing the user to obtain information about passers-by. This factor is also considered in our work, for providing pointed contents to users. Murugappan et al. [19] designed an extended multi-touch table via depth data collected by Kinect. It was not only able to support multi-touch, but also to retrieve information from user’s hand postures, identity and handedness. In this way, they extended more input modalities. Wilson et al [24] also probed touch interaction by processing depth data. They provided a good method for retrieving useful data from the depth image of Kinect. Compared to them, we used depth data to gauge the distance and position of users to the screen, and recognized the identification through a web camera which is more precise. Besides, we referred the fine-grained gesture interactions on screen. Wigdor et al. [23] presented a set of interactions, which augmented direct multi touch interaction with shape-based gestures. This improved the preciseness of direct manipulation and mitigated occlusion. Other researches such as [22] used a glove with color markers to carry out real-time hand tracking. Harrison [12] processed sound signal to explore more precise touches on tangible surfaces differenced by nail, pad, tip and knuckle to enhance touch interactions.

2. Sociable projection screen

Most public screens are currently un-interactive. In our work, we transform a normally projection screen into an interactive surface supporting 3-dimensional interaction. It accounts for user’s posture, identity, orientation, location and distance as implicit interaction input, rather than simple touch interactions. By means of Kinect, it is easy to collect the above user factors if we locate the Kinect in front of the screen. This is feasible for most existing public screen interactions. However, if the user stands too close to the screen, he/she exceeds the range of the Kinect, and it is impossible to display personal contents to the user due to privacy reasons. As a result, in our platform, we install Kinect near the ceiling facing the user’s back, as shown in Figure 2. The distance from Kinect to screen is about 2.5 meters. Then we mount a projector on the ceiling to project a screen on the wall. This deployment ensures Kinect can detect users regardless of their position.

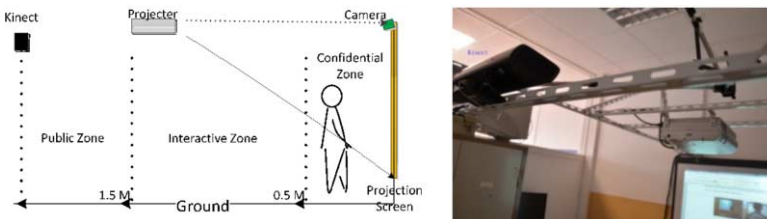

Figure 2 Deployment of proxemic platform

We divide the space in front of the screen into three zones:

Confidential zone (CZ): from 0 to 0.5 m in front of the screen. Users in this zone have maximum authority to interact. Also, the screen displays personalized and private contents to them;

Immersive zone (IZ): from 0.5 to 1.5 m in front of the screen. Users in this zone can browse and zoom in the contents on screen by gestures. Nevertheless, they have less priority than users in CZ;

Public zone (PZ): the space beyond 1.5 m. Users in this zone can only skim the current interfaces roughly and select the relevant one by simple gestures.

Based on this deployment, we build a proxemic platform with a sociable public screen as the center, which supports multi interaction modalities, as shown in Table 1. We use Kinect with windows SDK 1.7.0 for implementation.

Table 1 Interaction Modalities Supported by the Platform (√ supported, × not supported)

Interact Modality	C Zone	I Zone	P Zone
Left or Right Hand Cursor	√	×	×
Push or Wave to Click	√	×	×
Glide to Scroll	√	×	×
Presenter Position Interact	√	×	×
Browse and Zooming Gesture	√	√	×
Sitting Position Interact	√	√	×
Roughly Skim Gestures	√	×	√

In the following sections, we describe the different interactions in the three zones.

2.1. Interaction modality in the Confidential Zone

If someone enters the CZ, we infer that he/she intends to interact with the screen. Unlike the direct touch interaction of the traditional touch screen, the projection screen senses the user before he/she crosses the border between CZ and IZ, while the camera mounted on top of the screen also recognizes the user via face recognition. We define several interactions by gestures and postures in this zone, as follows:

Users could move their left hand to control the cursor for selecting the relevant contents. We obtain the user's skeleton info from Kinect, then scale the 3-dimensional coordinates of the hand joints to 2-dimensions via the built-in function of Kinect SDK. However, assignment of these scaled coordinates as cursor coordinates is not feasible, else, when the user directly touches the screen, the cursor position would have a large offset with the actual hand position. We need to mitigate the offset to avoid malfunctioning. We adjust the deviation by adding two empirical coefficients α and ϕ to the scaled coordinates.

$$CursorX = \alpha \times \frac{\text{interfaceActualWidth} - \text{scaledHandX}}{\text{interfaceActualWidth}} \times \text{ScreenResolutionWidth} \quad (1)$$

$$CursorY = \phi \times \text{scaledHandY} \times \frac{\text{interfaceActualHeight}}{\text{ScreenResolutionHeight}} \quad (2)$$

In our deployment, screen resolution is 1600×900, while interface resolution is 1920 × 1080. We conducted many tests to calibrate the coefficients. After comparison

of different pairs of the two coefficients, we found that the best values are $\alpha = 0.8$, $\varphi = 1.3$, with which we obtain a minimum deviation between the hand and cursor position. The deviation is amplified if the user removes his/ her hand from direct touching on screen. However, inside the border closer than 0.5 m, this offset is acceptable. For large displays, the user has difficulties reaching items out of hand's reach, so it needs to amplify the hand's cursor as well. In this case we set $\varphi = 1.3$ as the coefficient of the Y axis, to balance the two opposite requirements. The same problem is also present in the X axis, as it is hard for the user to reach the item on the right side of the body with his/ her left hand. As a result, if Kinect detects that the user wants to reach the item to the right with his/ her left hand by his/ her posture, it relates the coordinates of the right hand with cursor movement instead of the left hand. Thus the user can move the cursor with his/ her right hand.

We have devised two methods for the click method. Once the user has selected an object, he/ she could push his/ her hand straight forward to click and open it, as shown in Figure 3. Or, alternatively, the user could wave his/ her free hand to click the current items as well. The push gesture is more natural than the latter, while the latter is more precise. This is because, when the user pushes his/ her hand forward, hand depth is changed, causing sudden drifting of cursor coordinates. The user might click another item by mistake. To solve this problem, we save the previous cursor coordinates in the memory. Once Kinect has detected the user's push gesture, it reads the previous data from the memory and re-assigns the data to the current cursor to avoid cursor drifting.

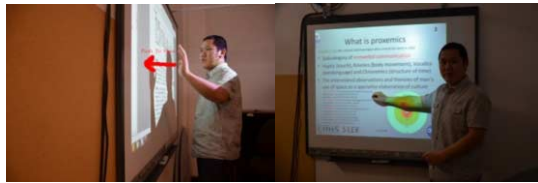

Figure 3 Left: push to open, Right: user interact with the hand close to screen

Normally the user scrolls the contents on the screen to check details. During our previous investigation via Wizard-Of-Oz [13], we found that the user always moves his/ her hand on the screen from top to bottom to scroll down the contents. We adopt this spontaneous behavior for contents scrolling. The user glides his/ her hand from top to bottom quickly, and the current page scrolls down. Similarly, if the user glides his/ her hand from bottom to top, the page scrolls up, as shown in Figure 1.

In the CZ, we sense the user's orientation as well. If the user wants to present something (such as a photo, slide, etc.) to others, he/ she turns back and faces the others standing in front of the screen. We detect the change in orientation, allowing users to control the contents using the hand close to the screen. The other hand is used to assist, as shown in Figure 3. The tester raises his/ her left hand, then moves his/ her right hand to cause rapid skimming over the current interface. If he puts his/ her left hand down, his/ her right hand will only control cursor movement.

2.2. Interaction modality in the Immersive Zone

In the IZ, users have limited possibilities to interact. They cannot interrupt the current interactions of the user standing in the CZ unless the CZ is available. Instead, they can browse the contents by waving their right or left hand, to control the last and next page.

In this zone, users stand at a large distance from the screen, and we need to let users zoom in on the content for easy reading. In our previous work [13], we tried to set the zoom in action by the user's intuitive movement such as walking towards the screen. However, test results showed that users easily triggered the zoom unconsciously. Therefore we have defined several explicit gestures for zooming. When the user raises his/ her right hand, this means zoom in on the current contents, otherwise, if he/ she raises their left hand, it means zoom out, as shown in Figure 4.



Figure 4 Gesture Interact of user in IZ (scroll up, down, zoom in and out)

The screen also senses the user's sitting position. In our prototype, if the user takes a seat, we infer that he/ she wants to read the current contents in full screen mode, and the screen displays the current contents on full screen. The user can control the next and last page by waving his/ her hands. The full screen mode exits once the user stands up.

The sitting position is especially helpful to detect disabled people in wheelchairs. For example, in metro stations, if a disabled person approaches the screen, it displays the position of the entrance with an elevator.



Figure 5 Left: user's sitting position in IZ, Middle: skim interface in PZ, Right: file migrator operation

2.3. Interaction modality in the Public Zone

In the PZ, users can only skim the current running interfaces, by waving their left and right hands to select, as shown in Figure 5. Unless the user steps into the inner zone, he/ she cannot engage any further interaction. If no users are present in the work space, the screen clears the contents and waits for the next user.

As aforementioned, the platform supports resource exchange among different devices. Users, public screens and ambient mobile devices are aware of each other and can "communicate" seamlessly. Using the WIFI module widely embedded in mobile devices, we have built a file migrator toolkit, which has a mobile version implemented on Android 4.0 or higher, and the desktop version in Java.

3. File migrator

Compared to file transmission by Bluetooth or maker based, WIFI is a more practical and quicker way for exchanging resources: it is not limited by devices and the surrounding environment, and is easy to configure. Although there are many tools for

share files with computers via WIFI, they are not suitable for application with public screens. Most tools configure the mobile device as a hotspot, and users access the files via the web explorer in computers. They can read and modify all the files in mobile devices. However, this method generates privacy problems if it is used with a public screen. The user connects his/ her mobile devices to the hotspot of public screen, he/ she might just want to share a single file, but has to publish all the files in the public network. Regarding this problem, we have developed a highly efficient file sharing tool based on client/server structures. It is designed to transfer resources naturally among all ambient devices in the vicinity of the public screen.

3.1. Flick to send

Users naturally explain “send out” intentions with a flick gesture: specific to the case of mobile devices we consider that if the user glides a finger from screen bottom to top, he/ she wants to send out a file, as shown in Figure 5. First the user selects a file from the list, and glides a finger from bottom to top, and then the file is sent out. Public screen users expect to get instant feedback from the screen to verify whether the file has been successfully sent. Thus, after the file has been accepted, it will be opened instantly on the projection screen. This is useful if one user wants to present something, such as photos, slides or files stored in his/ her mobile devices to others.

3.2. Draw or Shake to receive

Compared to the send action, users could “draw” a file from the screen by selecting and sliding a finger from top to bottom. Alternatively, we employed the embedded accelerators of mobile devices to produce the “shake to receive” effect. In our vision, users do not need to take their phone out for downloading a file from the screen, they just shake the mobile phone in their pocket and the file will be downloaded automatically. This means users no longer bother to scan the QR code, or take pictures.

The file migrator is a lightweight toolkit oriented to the ad hoc resource-sharing requirement in public spaces. It connects the user with the public screen, as well as the others’ devices seamlessly. This is convenient for daily social life: for example, if two friends meet in the street, they want to exchange their name card stored in their mobile phones. There is no need to manually input, one person just sends the card by flick and the other person receives it by shake, and the exchange is finished. Additionally, in local communities, several friends gather in the bus shelter to wait for the bus. While they wait, they could easily share their interesting topics, such as photos or videos with others by publishing the file on the screen. This extends the public screen as a sociable medium putting a variety of people in contact, and not merely a display for information.

4. Scenario Applied to the Public Transportation System

As aforementioned, the networked public screen will be pervasively used in the future smart city. Our platform provides a rapid and economic method for building an interactive and sociable public screen. We have envisaged application of this platform in several promising scenarios, such as for the public transportation system (bus shelter

or metro station), and other public service screens for tourism, billboards or advertisements.

We take the bus shelter as an example to explain application of the platform in the public transportation system. Bus shelters are one of the most social occasions in the city. Passengers obtain information from the screen mounted on a bus shelter. Today they can only obtain information about bus schedules, and most screens are not interactive, let alone sociable. We should take advantage of the time while passengers wait for a bus, to make the screen work as a more useful medium than a simple bus schedule. Passenger mobility is another advantage of the public screen in the bus shelter, as various user samples mean more abundant interactions. Therefore, in our vision, we reform the normal bus shelter as the info island for passengers [6], as shown in Figure 6. It provides not only transportation information, but also shopping, culture and sport information, as well as local personal information.

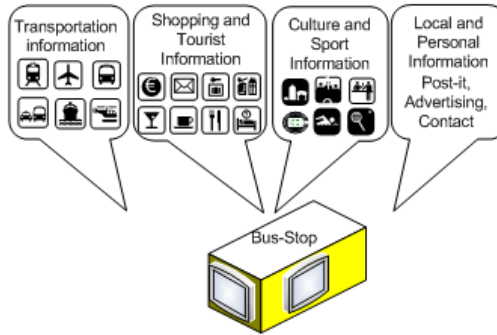

Figure 6 Bus shelter info island with sociable public screen

Passengers fall into two typical types in the bus shelter: local inhabitants and tourists. Each type has different concerns about the bus shelter. Compared to local inhabitants, tourists are concerned with the schedule, route map and connections, while inhabitants, familiar with this information, are more concerned with local community messages, such as entertainment, advertisements etc. We describe the different interact scenarios for the two kinds of users.

4.1. For Tourists

Tourists come to the bus shelter not only to take the bus, but also to check local information, and quickly find the tourist attractions, or restaurants. Normally, tourists standing in the public zone obtain general information such as bus arrival time etc. If he/she steps further into the immersive zone, two selectable boxes will appear, called “Tourist” or “Inhabitant”. He/she then waves his/ her hand to select Tourist, and the screen displays the categories specialized for tourists, such as “Museum”, “Restaurant”, “Hotel”, “City Bike”, “Emergency” and “Transport”. He/ she can select the category using the simple gestures mentioned above.

Tourists only need to click a button to display the relevant interface. They can use gestures to scroll contents, as well as zoom. They need to step further into the confidential zone if they want to check details. In the CZ, users can engage more abundant interactions. As tourists have no personal data stored in the public screen network, the camera will not recognize them, and no personal information can be

displayed. Nowadays, tourists often want to search for a WIFI hotspot, as their mobile phone does not work in foreign countries. Therefore the screen displays their WIFI code and they can connect their phone to the local hotspot. They can then download files easily from the screen, such as tourist maps, restaurant addresses and transportation maps. Or they can share their favorite photo of a local monument in their mobile phone on the screen, and the photo will be published in the open display network, so that others can enjoy this photo from all the other screens in the network.

We have envisaged other interesting applications to build sociable connections between people. Under the museum menu, there will be special charts displaying the popularity of local museums. Tourists can rate their favorite museums based on their own experience, and check out others' comments, as well as add comments to others' views. Some museums always offer discounts for group visitors, individual tourists could create a note with their mobile devices to invite other sightseers to visit the museum together, then send the note to the screen. This will then be announced on the public display network, and other tourists can read this note from any bus shelters and accept the invitation. Not only is this a good opportunity to build a subtle relationship, but it is also a good way to introduce tourist-related business.

4.2. Local inhabitants

Unlike tourists, local inhabitants are familiar with the schedule, and thus less concerned with transportation information. The interface that the inhabitants see in the public zone is the same as for tourists. However, when someone enters the interactive zone, he/ she selects "Inhabitants" to display the various categories such as "Restaurant", "Cinema", "Concert", "Emergency" and "Community news". If they step into the confidential zone, the camera will recognize their identity. According to the favorites analyzed from their browse histories, and other records from their social web accounts (Facebook, Twitter or G+), the screen can display personalized information, such as recent news of their friends, greetings from others, etc. For example, if they have shared a video about a recently released film on Facebook, the screen can display when the film next shows in the nearby cinema. Moreover, it displays the local inhabitants interested in this film as well. They could invite someone to see this film together, though they might not know each other. The next time the other inhabitant accesses the screen, he/ she will be reminded of the invitation. By this means we enhance the social relationship among strangers. Furthermore, as the screen and user's devices are networked, local inhabitants could exchange their files in the mobile devices with the public screen, such as download a restaurant voucher, publish a Lost and Found ad., etc.

5. User study

We invited 10 volunteers for a user study (3 females, 7 males), with an average age of 26.5, and an average height of 172.7 cm. We asked them to carry out specific tasks, and recorded the total test time. They all use their mobile devices every day: 7 use IOS devices, while only 2 use android devices, and 1 uses a windows phone.

5.1. Sociable screen interaction task

We explained and demonstrated the interaction process to participants, and asked them to interact with the screen in three different zones. First they stepped into the **public zone**, and skimmed the current interfaces running on the screen, then they chose one open web page about the “Transportation common Lyonnais” and entered the **immersive zone**. Once in the IZ, they tried to control the scroll and zooming operation of the current interface. After successfully finishing these actions, they stepped into the **confidential zone**, the screen displayed them with personal information, and reminded them to control the cursor with their left or right hand (depending on user position). Participants were asked to click the button by one of two methods: wave the other free hand, or push the current active hand. We compared the efficiency of these two gestures. Finally, the user turned away, and the screen returned to neutral state.

5.2. File migration task

We uploaded the Android app file (.apk) in the local server, and asked the participants to download this apk file from the local server and install it in the mobile devices. They could either use their own android devices or we offered them the Sony ST18i mobile phone and Nexus 7 tablet. There are user’s instructions in the app interface. Participants were required to send a jpg, pdf and ppt file to the public screen and another mobile device respectively, and they tried to receive the file from other ambient devices by shake mobile phones and glide finger.

5.3. Test results

We recorded the total test time that the 10 participants took to complete the two tasks. As shown in Figure 7a, participants needed on average 10.6 minutes to finish the first task, and 2.7 minutes for the second. They spent more time in the learning process of screen interaction, and needed time to adapt to the various gestures, especially in the confidential zones. However, once they practiced a little, they adapted well to the gestures. The migration toolkit is easier to learn and use. All the participants were able to finish the required tasks successfully. Only one person accustomed to IOS devices initially had some problems with the UI of android devices.

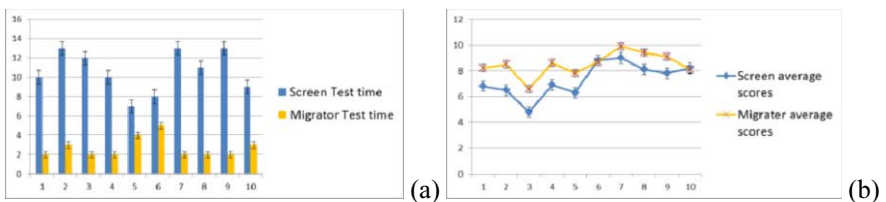

Figure 7 a: Total test time for each user (minutes) and b: Scores of satisfaction

We asked users to evaluate the usability of our prototype by grade, from 0 to 10, the higher scores being positive and vice versa. We asked them 12 questions for screen interaction, related to experience of learning, gesture interaction and proxemic interaction, etc. We then listed another 8 questions concerning the file migrator. We calculated the average satisfaction of the ten users, as shown in Figure 7b. Comparing

these two charts, it is obvious that satisfaction is low if they spent more time on the required task.

Through analysis of the questionnaire and conversation with participants during the usability test, we found that users complained mostly about the two parts of screen interaction: click selected items and alter control between left and right hands. For example, the user naturally stretched his/ her left hand to the right if he/ she wanted to click an item in the right side of the screen, rather than changed to his/ her right hand to select. Besides, when the surrounding light is too weak, cursor position had a large offset with hand position. Another problem raised is that if the user's hand is occluded by his/ her body, Kinect cannot detect the hand, thus causing malfunctioning. Regarding the file migrator, most users are happy with the instant and natural migration of files, and find it practical for satisfying resource exchange requirements on the public screen.

6. Conclusion and future work

In this paper, we presented a proxemic platform consisting of a sociable screen aware of user's proxemic attributes, and a file migrator for ad hoc resource exchanging among ambient devices. The sociable projection screen attracts users by discovering them proactively. Users interact with the screen implicitly by a 3-dimensional position relationship and explicit gestures, rather than plain multi-touch interaction. The screen functions as a sociable medium rather than a merely interactive surface. We also demonstrated the file migration toolkit oriented at social life in the public zones of the smart city, increasing the efficiency of resource exchanges between different devices. We envisaged the application scenario of the platform in the future bus shelter, and discussed its effect on connecting citizens and enhancing the social relationship between people. We did the preliminary user study to demonstrate the usability, as well as the possible problems. We found that the platform is a practical way to build sociable and intelligent public zones in the smart city.

In future work, we will substitute the single Kinect deployment with multiple Kinects environment, to solve the occlusion problem with one Kinect, and design parallel interaction for multi users.

References

- [1] V. Bellotti, M. Back, W. K. Edwards, R. E. Grinter, A. Henderson, and C. Lopes, "Making sense of sensing systems: five questions for designers and researchers," in *Proceedings of the SIGCHI Conference on Human Factors in Computing Systems*, New York, NY, USA, 2002, pp. 415–422.
- [2] B. David, C. Yin, Y. Zhou, T. Xu, B. Zhang, H. Jin, R. Chalon. SMART-CITY: Problematics, techniques and case studies. ICCM'2012, *8th International Conference on Computing Technology and Information Management*, Seoul, Korea. pp. 168-174. *Computing Technology and Information Management (ICCM) 1. IEEE Conference Publications*. ISBN 978-1-4673-0893-9. 2012.
- [3] G. Cohn, D. Morris, S. N. Patel, and D. S. Tan, "Your noise is my command: sensing gestures using the body as an antenna," in *Proceedings of the SIGCHI Conference on Human Factors in Computing Systems*, New York, NY, USA, 2011, pp. 791–800.
- [4] S. Corbett-Davies, R. Green, and A. Clark, "Physically interactive tabletop augmented reality using the Kinect," in *Proceedings of the 27th Conference on Image and Vision Computing New Zealand*, New York, NY, USA, 2012, pp. 210–215.

- [5] N. Davies, M. Langheinrich, R. Jose, and A. Schmidt. "Open Display Networks: A Communications Medium for the 21st Century." *Computer* 45, no. 5 (2012): 58–64.
- [6] B.David, and R.Chalon. "Hotspot Based Mobile Web Communication and Cooperation: ABRI+ Bus Shelter as a Hotspot for Mobile Contextual Transportation and Social Collaboration." *international Conference on Semantic Web & Web Services (SWWS 2010)*, Las Vegas, Nevada, USA.CSREA Press, pp. 184-189.
- [7] B.David, and R.Chalon. "IMERA: Experimentation Platform for Computer Augmented Environment for Mobile Actors." In *Third IEEE International Conference on Wireless and Mobile Computing, Networking and Communications*, 2007. WiMOB 2007, 51–51.
- [8] D. Vogel and R. Balakrishnan, "Interactive public ambient displays: transitioning from implicit to explicit, public to personal, interaction with multiple users," in *Proceedings of the 17th annual ACM symposium on User interface software and technology*, New York, NY, USA, 2004, pp. 137–146.
- [9] F.Alt, and A Schmidt. "Advertising on Public Display Networks" *Computer* 45, no. 5 (2012): 50–56.
- [10] H. Gellersen, C. Fischer, D. Guinard, R. Gostner, G. Kortuem, C. Kray, E. Rukzio, and S. Streng, "Supporting device discovery and spontaneous interaction with spatial references," *Personal Ubiquitous Comput.*, vol. 13, no. 4, pp. 255–264, May 2009.
- [11] S. Greenberg, N. Marquardt, T. Ballendat, R. Diaz-Marino, and M. Wang, "Proxemic interactions: the new ubicomp?," *interactions*, vol. 18, no. 1, 2011, pp. 42–50.
- [12] D. Guinard, "Towards the web of things: Web mashups for embedded devices," In *Proceedings of WWW 2009*. ACM, 2009.
- [13] C. Harrison, J. Schwarz, and S. E. Hudson, "TapSense: enhancing finger interaction on touch surfaces," in *Proceedings of the 24th annual ACM symposium on User interface software and technology*, New York, NY, USA, 2011, pp. 627–636.
- [14] H. Jin, T. Xu, B.David, R.Chalon, Proxemic Interaction Applied to Public Screen in Lab. *HCI International 2013*, LNCS 8028, pp.378-387.
- [15] W. Ju, B. A. Lee, and S. R. Klemmer. "Range: Exploring Implicit Interaction Through Electronic Whiteboard Design." In *Proceedings of the 2008 ACM Conference on Computer Supported Cooperative Work*, 2008, 17–26.
- [16] N. Marquardt., R. Diaz-Marino, S. Boring, and S. Greenberg. "The Proximity Toolkit: Prototyping Proxemic Interactions in Ubiquitous Computing Ecologies." In *Proceedings of the 24th Annual ACM Symposium on User Interface Software and Technology*, 2011, 315–326.
- [17] N. Marquardt, K. Hinckley, and S. Greenberg, "Cross-device interaction via micro-mobility and f-formations," in *Proceedings of the 25th annual ACM symposium on user interface software and technology*, New York, NY, USA, 2012, pp. 13–22.
- [18] N. Marquardt, and S. Greenberg. "Informing the Design of Proxemic Interactions." *Pervasive Computing*, IEEE 11, no. 2 (2012), pp. 14–23.
- [19] S. Murugappan, Vinayak, N. Elmqvist, and K. Ramani, "Extended multitouch: recovering touch posture and differentiating users using a depth camera," in *Proceedings of the 25th annual ACM symposium on User interface software and technology*, New York, NY, USA, 2012, pp. 487–496.
- [20] T. Ojala, V. Kostakos, H. Kukka, T. Heikkinen, T. Linden, M. Jurmu, S. Hosio, F. Kruger, and D. Zanni. "Multipurpose Interactive Public Displays in the Wild: Three Years Later." *Computer* 45, no. 5 (2012): 42–49.
- [21] T. Xu, H. Jin, B. David, R. Calon, Y. Zhou. A Context-aware Middleware for Interaction Devices Deployment in AmI. *HCI International 2013*. Las Vegas.
- [22] R. Y. Wang and J. Popović, "Real-time hand-tracking with a color glove," *ACM Trans. Graph.*, vol. 28, no. 3, 2009, pp. 63:1–63:8.
- [23] D. Wigdor, H. Benko, J. Pella, J. Lombardo, and S. Williams, "Rock & rails: extending multi-touch interactions with shape gestures to enable precise spatial manipulations," in *Proceedings of the SIGCHI Conference on Human Factors in Computing Systems*, New York, NY, USA, 2011, pp. 1581–1590.
- [24] A. D. Wilson, "Using a depth camera as a touch sensor," in *ACM International Conference on Interactive Tabletops and Surfaces*, New York, NY, USA, 2010, pp. 69–72.
- [25] Y. Zhou, B.David, R.Chalon.: PlayAllAround: Wearable One-hand Gesture Input and Scalable Projected Interfaces. Presented at the *ERGO-IHM 2012*, Biarritz, France. ACM. ISBN 978-1-4503-1015-4.

TRART: A system to support territorial policies¹

Carla BINUCCI², Walter DIDIMO, Giuseppe LIOTTA, Fabrizio MONTECCHIANI,
and Mariano SARTORE
University of Perugia, Italy

Abstract. We present a multimedia software platform aimed at contributing to the implementation of territorial policies to improve and develop the liveability and sustainability of urban and suburban areas. The system offers two main features: It supports citizens to explore places of art, architecture, culture and landscape, through a personal experience based on their interests; it provides local administrators and politicians with monitoring tools to take decisions and improve the quality of the existent services or design new territorial policies.

Keywords. *polycentrism, smart city, liveability, sustainability*

Introduction

The research described in this paper arises from a collaboration between the Italian Region Umbria and the University of Perugia. The aim of this collaboration is to design a multimedia software platform that supports the territorial policies of the region by emphasizing its polycentric nature. The territory of Umbria consists of several small medieval towns, scattered in a beautiful natural landscape and linked to one another by historical routes. This *polycentrism* suggests to emphasize not only the attraction points but also the connections among them. Therefore, one of the goals of the territorial policies of the region is to produce travel itineraries that are themselves an environmental and cultural experience for citizens and tourists. At the same time, local administrators and politicians should be able to monitor the flow of travelers, taking advantage of this information to improve the quality of the related services (e.g., public transportation) and to emphasize the characteristics of more rural and less visited portions of the region. Clearly, this scenario can be extended to cope with the needs of a big city, where several attraction points are distributed through out the large city area. Furthermore, this original approach supports the definition of sustainable and liveable city given in [2]. Indeed, it enhances the exploration of art, architecture and landscape and gives tools to improve the contact and mobility of the city [2].

In what follows we describe TRART, a multimedia software platform capable of providing several features to achieve the goals described above. Among them:

- *Thematic itineraries* based on user's interests and needs. The thematic can be art, architecture, culture, landscape, or a combination of them. The system takes account of the transportation mean and the travel time desired by the user.

¹ Research partially supported by *Regione Umbria*.

² Corresponding Author: Carla Binucci, University of Perugia, Italy. Email: binucci@diei.unipg.it

- Access to multimedia contents while traveling, through the mean of augmented reality. The view of the user can be enriched by multimedia elements and additional information.
- Interaction among users visiting near attraction points or traveling along the same route. Nearby users can communicate each other and share multimedia contents about their travel experiences.
- Monitoring tools for local administrators are provided. These tools should take advantage of information visualization techniques (see, e.g., [1,8]) to display the flow of travelers and their behaviors.

Several tools have been developed to provide itineraries for tourists. However, most of them provide precomputed itineraries that cannot be customized by the user according to her interests. On the other hand, the web application CityTripPlanner³, developed in 2009 by the spin-off DyNAVic headed by Belgian University of Leuven, presents similarities with our system. This web application helps tourists in planning their itineraries based on their personal interests. Indeed, the application asks the tourist to answer some questions to determine its interests profile and then suggests a customized itinerary, which is displayed on a map together with a description and some photos of the places to be visited. However, the application CityTripPlanner has the following main limitations: (i) It concentrates on a small number of urban areas and does not consider interconnections among them; (ii) it only allows users to move on foot, while our system considers different transportation means; (iii) augmented reality is not provided. Furthermore, as far as we know, it is mainly oriented towards the end-user, while lacks of tools for local administrators to customize, extract, and analyze information.

The reminder of this paper is organized as follows. In Section 1 the multimedia software platform TRART is presented. Namely, we describe the data source 1.1, the software architecture 1.2, the algorithmic engine 1.3 and the monitoring tools 1.4. Finally, conclusions and future work are discussed in Section 2.

1. Multimedia Software Platform

In this section we describe the multimedia software platform TRART. In particular, we briefly describe the high-level architecture of the system, the technologies we used for its development, and the main algorithmic aspects.

1.1. Data Source

The system requires the geographical information of the territory of Umbria, which models points of interests and links among them in a standard GIS format. Furthermore, the system takes advantage of a *knowledge repository*, i.e., a database containing multimedia contents regarding the territory of Umbria. This information has

³ <http://www.citytripplanner.com/>

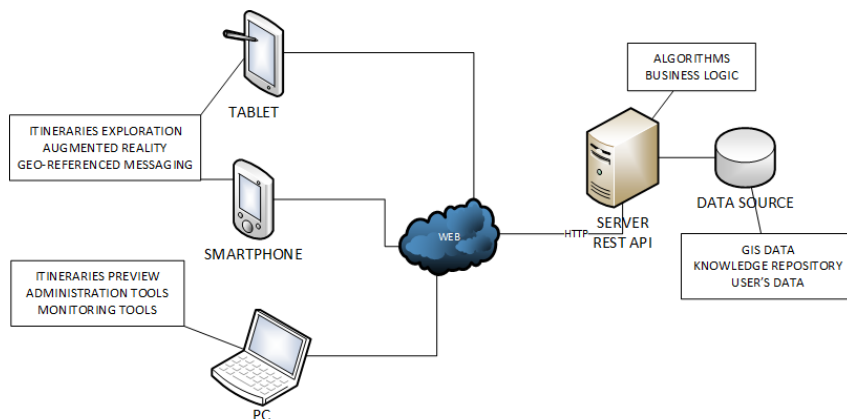

Figure 1. High-level architecture of the TRART multimedia software platform.

been cataloged from various sources, including the archives of ministry of culture and the local institutions of the region (e.g., libraries and foundations). These multimedia contents are associated with points of interest (e.g., towns, monuments and routes) and define the thematics of these points. Finally, the system stores user's preferences and data, as well as logging information, into an additional database.

1.2. Software Architecture

The software platform presents a client/server architecture based on web services. The server side has been developed in Java and provides a REST API accessible via HTTP by the clients. It implements the main logic of the application and it is connected to the data source. The client side has been developed in different technologies to optimize its use. Namely, we developed an HTML client, mainly intended for administrative use; an app for the Android system and an app for the iOS system. The two apps are geared with augmented reality, geolocalization and messaging. See also Figures 1 and 2.

1.3. Algorithm Engine

A key module of the system is the one that computes the thematic itineraries. It applies an algorithm that models the territory as a weighted network: The nodes of this network are points of interest (e.g., towns, monuments and routes) associated with a set of weights, one for each thematic; the edges represent connections among nodes. Both nodes and edges are associated with a set of costs, representing the travel time by different transportation means, e.g., car, bike, on foot and public transportation. We observe that also routes can be represented as nodes in the network, since they may be associated with a specific thematic (e.g., landscape).

In order to compute an itinerary, the algorithm takes as input the following parameters specified by the user: A source and a target node, a set of scores (one for each thematic), the transportation means, and the maximum travel time. The output is a tour that requires at most the maximum travel time and that tries to include the nodes with the highest weight according to the user preferences. This problem is a generalization of the well known Traveling Salesman Problem, which takes into

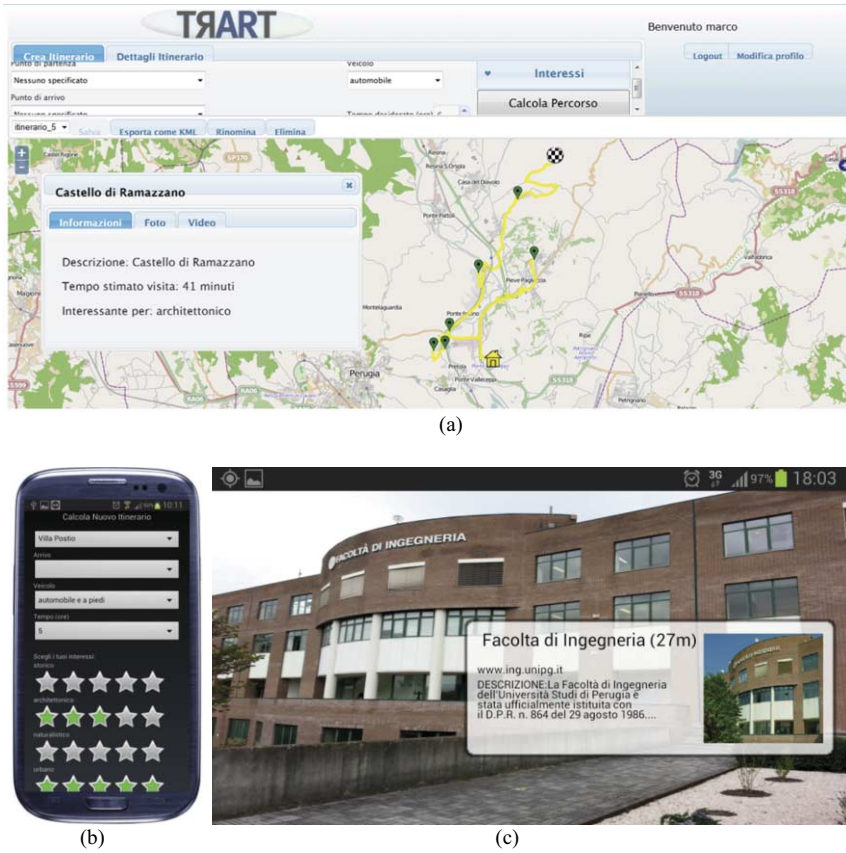

Figure 2. (a) A snapshot of the HTML client showing a computed itinerary. (b) A snapshot of the Android app showing the menu to define the parameters for a new itinerary. (c) A snapshot of the Android app showing a multimedia content over a point of interest.

account several constraints and optimization parameters. Since the Traveling Salesman Problem is NP-hard [6], we developed a heuristic to solve our problem in a greedy fashion. In the following we give a more detailed description of the algorithm. We need to introduce some notation. Denote with S the sequence of the nodes of the tour computed by the heuristic. Clearly, S is an ordered sequence where the first and the last nodes are the source and the target nodes specified as input by the user. Moreover, denote with C a set of nodes of the weighted network whose weights (computed based on user's preferences) are greater than a prefixed threshold. The nodes of C are sorted by descending preferences. At the beginning, S contains only the source and the target nodes. In order to add nodes to S (i.e., to add nodes to the tour), the heuristic considers the current heaviest node u of C and tries to insert it in S after or before the last inserted node. If it is not possible, i.e., the maximum travel time is not respected, u is removed from C . In order to decide if u can be inserted in S the algorithm computes the shortest paths (exploiting Dijkstra's algorithm [4]) between u and each other node that currently belongs to S . Based on the costs of the computed shortest paths, the algorithm first decides if u must be inserted before or after the last inserted node in S , then it inserts u

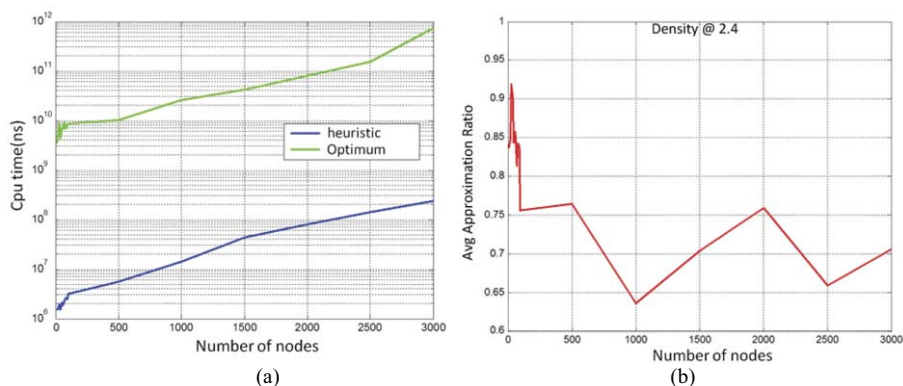

Figure 3. (a) The CPU time of the exact algorithm and of the heuristic. On the horizontal axis are reported the nodes of the network, while on the vertical axis is reported by a logarithmic scale the CPU time expressed in nanoseconds. (b) The gap between the solutions computed by the heuristic and those computed by the exact algorithm. On the horizontal axis are reported the nodes of the network.

in S only if the cost of such path plus the cost of visiting node u is less than or equal to the maximum travel time specified by the user.

In order to evaluate the performance of the proposed algorithm in terms of CPU time and quality of computed solutions, we developed an exact algorithm that computes the optimum tour, namely the tour that has maximum weight within the specified maximum travel time. The exact algorithm substantially enumerates and explores all possible solutions and selects the best one. We performed an experimental comparative analysis of the two algorithms on a test suite composed of randomly generated weighted networks with a number of nodes up to 3000 and density 2:4 (i.e., number of edges divided by number of nodes). Figure 3 shows that the heuristic provides a good approximation of the optimum and it can be used in real-time applications. Indeed, Figure 3(a) shows that the heuristic is about one thousand time faster than the exact algorithm, while Figure 3(b) shows that the gap between the weight of the solutions computed by the heuristic and the weight of those computed by the exact algorithm is always less than 35%.

1.4. Monitoring Tools

The system should provide tools to monitor the flow of travelers from different perspectives. Here we give a list of the most relevant tools currently under design:

- In order to understand whether the current public transportation and infrastructures are enough to fulfill travelers' needs, local administrators should be able to see which routes are the most traveled and which places are the most visited. In this sense, it is useful to distinguish the traffic based on specific time intervals in a day and on the transportation means.
- In order to understand if some thematic areas are below the expected level of interest or to enhance those parts of the territory that are less visited, it is important to monitor which thematic areas are the favorite ones to compute itineraries and how these thematic areas are distributed on the territory.

The tools described above can take advantage of information visualization techniques

to allow users to see, explore, and understand large amounts of information in intuitive ways [1,8]. A brief discussion on the on-going work about these tools is reported in the next section.

2. Conclusions and Future Work

We presented a multimedia software platform aimed at contributing to the implementation of territorial policies to improve and develop the liveability and sustainability of urban and suburban areas. The system is still under development, a prototype version has been recently deployed⁴.

Currently, we are designing the monitoring tools, whose goals are described in Section 1.4. In particular, we aim at using a uniform visualization framework to display the network of the territory. The framework provides two levels of abstraction. The first level displays the network respecting the geographical positions of the nodes. The problem of combining the visualization of geographical and non-geographical information has been extensively studied, see, e.g., [3,9]. Building on these techniques, the first level emphasizes the flow of travelers over the network. The second level abstracts the geographical information and computes a representation of the network optimizing its readability. Namely, less relevant information about the flow of travelers is discarded, as well as the geographical positions of the nodes are not taken into account. Therefore, the network can be visualized by using an abstract representation, such as the *metro map metaphor*, which has been used successfully for visualizing abstract information [5,7].

In the near future we plan to include the concept of *gamification*, i.e., to integrate typical elements of gaming in the system, like ranking, scores, missions, rules and awards. The goal is to make the user experience more funny, interesting and engaging.

References

- [1] G. Di Battista, P. Eades, R. Tamassia, and I. G. Tollis. *Graph Drawing: Algorithms for the Visualization of Graphs*. Prentice Hall, 1998.
- [2] D. Clements-Croome. Intelligent sustainable liveable cities. In *Intelligent Environments*, pages 1–9, 2012.
- [3] G. Di Battista, C. Squarcella, and W. Nagele. How to visualize the k-root name server. *JGAA*, 16(3):675–699, 2012.
- [4] E. Dijkstra. A note on two problems in connexion with graphs. *Numer. Math*, 1(1):269–271, 1959.
- [5] M. Fink, H. Haverkort, M. Nöllenburg, M. Roberts, J. Schuhmann, and A. Wolff. Drawing metro maps using bézier curves. In *Graph Drawing*, volume 7704 of *LNCS*, pages 463–474. Springer-Verlag, 2013.
- [6] M. R. Garey and D. S. Johnson. *Computers and Intractability: A Guide to the Theory of NP-Completeness*. W. H. Freeman & Co., 1979.
- [7] S.-H. Hong, D. Merrick, and H. A. D. do Nascimento. The metro map layout problem. In *Graph Drawing*, volume 3383 of *LNCS*, pages 482–491. Springer-Verlag, 2004.
- [8] A. Kerren, J. T. Stasko, J.-D. Fekete, and C. North. *Information Visualization: Human-Centered Issues and Perspectives*. LNCS. Springer-Verlag, 2008.
- [9] D. Mashima, S. Kobourov, and Y. Hu. Visualizing dynamic data with maps. In *IEEE PacificVis*, pages 155–162, 2011.

⁴ <http://mozart.diei.unipg.it:8080/UmbriaTourServlet/index.html>

To login use - User: utente Password: utente

Smart City Search: A User Survey

Richard MIETZ^{a,1}, Kay RÖMER^a

^a*Institute of Computer Engineering, University of Lübeck, 23552 Lübeck, Germany*

Abstract. The number of sensors deployed in cities is growing from year to year due to different drivers such as sensors contained in embedded systems, smartphones, weather stations, and sensor networks. When connecting these sensors to the Internet, the state of the city is available online and in real-time, thus, realizing the vision of an Internet of Things (IoT). The combination of this sensor knowledge with data from other sources and services makes cities "smarter" and enables novel applications such as finding free parking spots. A key service for many of those applications is a search engine. This *Smart City Search* would allow users to search and find entities of the real-world which exhibit a certain state at query time. To inform the design of such a search engine, we conducted a user survey to identify usage patterns and desires of users for *Smart City Search*.

Keywords. Internet of Things, Smart City, Search, Sensor, Survey, Questionnaire

Introduction

Through technological progress the number of sensors in our environment is constantly growing. Modern smartphones contain, among others, sensors for acceleration, light, sound, and position. Both, the commercial and crowdfunding communities started to develop and sell additional sensor equipment for mobile phones to measure environmental conditions such as temperature, humidity, or different gas concentrations. Additionally, several projects and companies are working on sensors for the household to, e.g., detect presence or accidents of people. Finally, researchers deploy sensor networks in cities. One of the most noteworthy efforts is the SmartSantander project² where 20.000 sensors will be deployed and connected to the Internet over four cities of which 12.000 are set up in the Spanish city of Santander. These trends will facilitate an Internet of Things (IoT) where entities of the real world are connected to the Internet and publish their state in real-time. In [1], ICT infrastructure such as the IoT is, among others, characterized as a pillar for so-called Smart Cities. "Smart" means that combining data from sensors and other sources will allow a multitude of new applications and services which can "[...] fuel sustainable economic growth and a high quality of life, with a wise management of natural resources [...]" [1]. For example, SoundOfTheCity [2] is a smartphone app which measures the sound intensity around the user with the microphone and uploads it to a central server. The collected noise levels of all users are displayed on a map. In this way, users can find, e.g., quiet places to relax and authorities can, e.g., use the data for urban development to reduce noise. Some other imaginable scenarios are pictured in the

¹Mail of Corresponding Author: mietz@iti.uni-luebeck.de

²<http://www.smartsantander.eu/>

IoT comic book [3] which was supported by the IoT-i Project. As this example illustrates, searching entities with a certain state will be an important service for the Smart City. So, instead of searching only for the static homepage of a restaurant, one could search for an Italian, well-tempered restaurant which has free tables at the moment. The infrastructure for such *Smart City Search* must be, on the one hand efficient in terms of resource consumption because this is the limiting factor of most sensor systems such as smartphones and sensor nodes, but, on the other hand, serve the user with satisfying results. Hence, a user-centric design plays an important role. Therefore, we conducted a survey with 184 participants to gain insights into the usage patterns and requirements of users for *Smart City Search*.

This paper is structured as follows. In Section 1 the design of the questionnaire is presented. Section 2 analyses the results and draws conclusions for each topical scope of questions. Related work is discussed in Section 3. Finally, Section 4 concludes the paper.

1. Survey Design

We have created a questionnaire³ with a total of 44 questions, where, if not specifically mentioned, a single answer is allowed. The questions are divided into the five parts *GeneralQ*, *CreativeQ*, *GeneralUsageQ*, *ScenarioUsageQ*, and *ResultQ*. *GeneralQ* consists of questions dealing with the age, gender and prior knowledge about IT, Google services, and Google search functions. We used Google as a representative because it is the best known search engine provider. The block ends with the question if the participant heard the term "Internet of Things" before and if so, he should give a short explanation of the IoT. Answers from this block allow classification of the participating users. Afterwards, a description of the IoT is given so that the user understands the upcoming questions regarding search in the IoT. In *CreativeQ*, the participant should write down IoT search scenarios he can think of. In the other three questions, the participant is asked to formulate queries for three different scenarios. This should give an insight if users will use a specific syntax, a keyword-based query or natural language. The question block *GeneralUsageQ* asks for general usage patterns of IoT search, i.e., which devices and where to use IoT search as well as which personal data the user would reveal to improve the results. In the second to last part, *ScenarioUsageQ*, we introduce eleven search scenarios (see Table 1) and ask for the usage patterns for these scenarios in more detail, i.e., with which devices, when, how often, where, and in which context the participant would search for them. The questions of *GeneralUsageQ* and *ScenarioUsageQ* should clarify similarities and variations in usage patterns of different scenarios. In the end, the question block *ResultQ* asks the user how results should be displayed. We wanted to know, how many results to display on the first result page, which information to show, which accuracy the sensor state should have, and how to sort the found results. In this way, we can determine how result pages should be designed to satisfy the users' requirements.

2. Results of the Survey

The survey was online accessible for seven weeks in the beginning of 2013. It was mainly announced in mailing lists of the University of Lübeck which is associated with an uni-

³<http://www.iti.uni-luebeck.de/fileadmin/website/Mitarbeiter/Mietz/survey.pdf>

Table 1. Scenarios used in user survey.

Scenario key	Description
Bike	Search for a free bike at bike rental stations
Car	Search for a free car sharing vehicle
Taxi	Search for a free taxi
Parking	Search for a free parking spot
Table	Search for a free table in restaurants
Waiting	Search for short waiting times at fast food restaurants
Water	Search for water temperature for swimming possibilities
Item	Search for a lost item (with built-in position sensor)
Transportation	Search for position of public transportation (bus/train)
Streets	Search for jam-free routes
Place	Search for sunny, quiet places

versity clinic. The university is rather small and only offers studies related to medicine and computer science.

Standard tools (Excel) have been used to analyze the raw data. All results in plots are automatically aggregated from that except Table 2 which has been analyzed manually by grouping similar answers.

Finally, 184 people completed the survey. The gender distribution can be seen in Figure 1. The number of male and female participants in total as well as in most age groups is balanced. Due to the advertisement scheme, the age group of 20-29 years is, with 78.26%, overrepresented. This hypothesis is also supported by looking at the distribution of the profession: most participants are students (61.57%), researchers (9.26%), or persons employed in the medicine sector (7.41%). Hence, on the one hand the results are not representative for web users in terms of age and education, but on the other side the IT-related knowledge of the participants is still wide-ranging from non-expert web users to studied computer scientists working and doing research in the field of the IoT. 22.04% heard the term "Internet of Things" before and had a vague or clear idea of it. Nearly all participants knew Google web search (98.91%), maps (100%), and the routing function of the latter (78.38%). However, only 32.61% respectively 48.37% knew Google's location-based services Latitude and Places. And with decreasing number of participants knowing a service, the number of participants using it even more decreases. In the end, the results, although not representative, are interesting and give good hints on what to keep in mind when developing sensor search systems. In the following sections, we discuss the results of the questions related to IoT search related questions in detail.

2.1. How Do Participants Envisage IoT Search? – Essay Questions

The first part of IoT search related questions, *CreativeQ*, consisted of four essay questions and called for the creativity of the participants. First, users were asked to think about scenarios in a Smart City they would search for real-world entities. Up to this point of the survey only one concrete scenario, searching for free tables in restaurants, was mentioned to not bias the answers. Nearly 70% of the participants gave an answer mentioning a total of 297 scenarios from which 55 were distinct. One can categorize these scenarios into four different classes. The most frequently mentioned scenarios along with

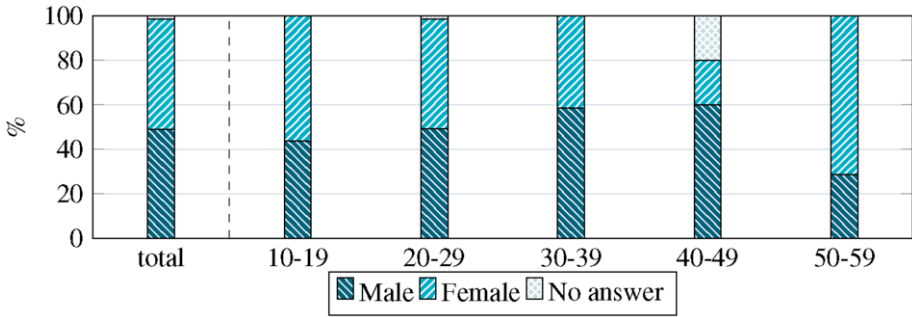

Figure 1. Total and age group divided distribution of gender.

the classes are given in no specific order in Table 2. Some scenarios can be seen in different ways and thus, categorized differently. For example, a search for car sharing vehicle can mean to find the number of available ones or the position of the nearest free one.

It can be seen that the given scenarios cover most areas of live from daily activities (shopping) and household (home appliances, heating) over learning (library) and leisure activities (sports, relaxing, culture) to social interactions (pet, friends, party). Only work is not explicitly present which can be explained by the occupation of the participants.

Table 2. Search scenarios proposed by the participants.

waiting time	availability	location	state
checkout lines	restaurant table	lost item	heating
attraction in amusement parc	cinema / theatre / concert ticket	next public transportation	home appliances
authority	parking spot	parcel tracking	temperature/weather
hair dresser	product in markets	car-sharing vehicle	light
doctor	seat in library	free bench	fuel price
service company	seat in public transportation	waves for surfing	water demand of plants
	book in library	friend	mood in bars
	car-sharing vehicle	pet	fill level of paper bank

The second part of this question block dealt with expressing queries to search for a *free table in a restaurant*, a *free table in a warm restaurant*, and a *free table in a restaurant with a free parking spot nearby*. The analysis shows that among the 90% of the participants who answered, most would express their request like they would do it nowadays with a web search engine, i.e., in a keyword-based fashion. However, it is also evident that many participants would like to have an interface supporting natural language querying. Finally, a small fraction of participants used a self-developed or known syntax such as SQL. The average/median number of used words for the three queries were 4.23/3, 5.93/5, and 6.11/5, respectively. This demonstrates that despite the growing complexity of the scenarios the length of queries for them is only increasing slowly. So, the total number of used words per query is low. Thus, understanding only from a query what real-world entities and states a user is looking for is a tough task.

Conclusion The results show that there is a strong need for natural language processing and understanding of the semantic meaning of a users' query because users often pose short queries with few words and without any specific syntax. To support the process of inferring the correct semantics from keyword-based or natural queries, it might be helpful to include several other aspects into the query resolution. For example, the location, time, context, and other personal information can give good indications on what the user intends to find. In the next section we investigate the characteristics of these attributes.

2.2. How Would Participants Use IoT Search? – General Search Usage Patterns

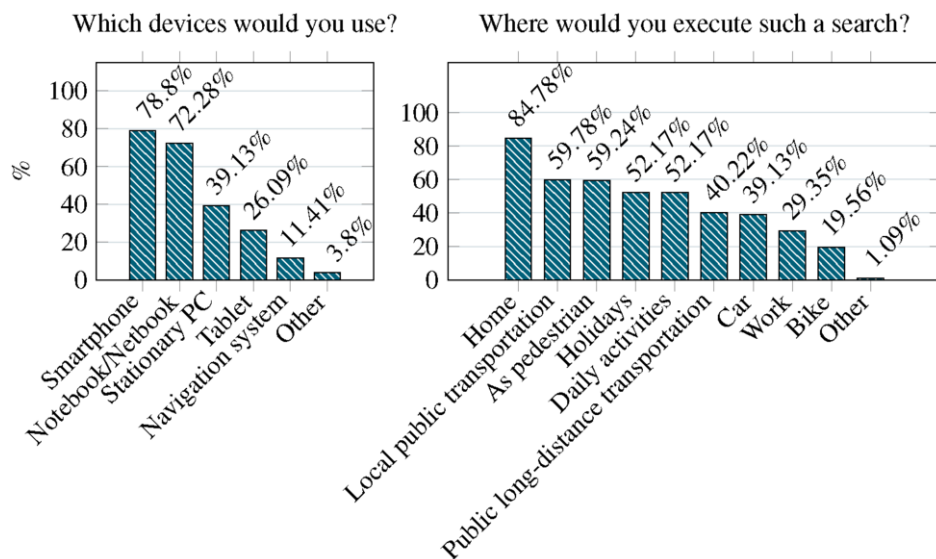

Figure 2. Results for question about general search behavior.

This part only contains questions where multiple answers are allowed and is about usage patterns of IoT search. It started by asking with which device and where the participant could imagine to pose a search query. The result plots are given in Figure 2. One can see that around 79% would use a smartphone. However, also mostly stationary devices such as notebooks and desktop computers are considered as an appropriate device to perform a search. Later on, the same question is asked for specific scenarios which will show that device choice is strongly dependent on the scenario. Although *Home* has the highest total percentage, the sum of all mobile usage scenarios exceeds home usage. The percentages for different types of mobile usage scenarios such as pedestrian or in public transportation are quite similar.

The third question is concerned with privacy issues. We wanted to know which personal information a user would pass on to the search engine to improve the search results. Especially when it comes to real-world entity search, information such as the position of the user, the preferences, or the religion can help to find the nearest or most appropriate restaurant, e.g., a vegetarian or kosher one. Figure 3 reveals that nearly $\frac{2}{3}$ have no problems to expose their position. Also basic information such as gender, age,

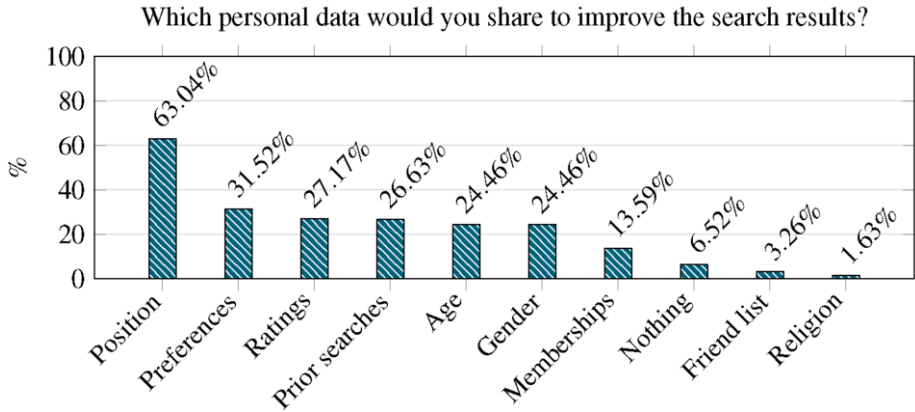

Figure 3. Results for question about sharing personal data.

and preferences would each be given away by more than 24%. On the other side, nearly nobody wants to bare his religion or friend list. 6.52% even want to reveal anything.

Conclusion Because search is used with several device classes, it is important to design search interfaces that are specifically tailored to the characteristics of each device. This includes, among other aspects, the screen resolution, available bandwidth, and supported user interactions. On a big screen all results should be displayed on a map in addition to a list view. In contrast, a low resolution screen should only show one of the views at a time but allow switching between them. Additionally, different contexts should also be considered at design time. When driving a car or bike, it would be useful to allow free-handed, distraction-free, speech-based query input.

Privacy issues are a tremendous challenge in the IoT when millions of sensors could potentially track people continuously. So, the user should have at least full control over his user search profile, i.e., what information he wants to reveal to improve his search results to build up trust in the Smart City.

2.3. How Would Participants Use IoT Search? – Usage Patterns of Search Scenarios

After asking about the general usage patterns of IoT search in *GeneralUsageQ*, *ScenarioUsageQ* aims to gain insight into the usage patterns for the scenarios listed in Table 1. Again, as in the previous block, for all questions multiple answer are allowed.

Just as in *GeneralUsageQ*, users would mainly use smartphones. Also, for other device classes the ratios are comparable to the one in *GeneralUsageQ*. Only the *Parking* and *Streets* scenario would be used by nearly $\frac{1}{3}$ of the participants with a car navigation system. These two scenarios are only outnumbered by smartphone usage.

Instead of detailed answer options about the usage place as in *GeneralUsageQ*, we broke the question down and asked where (home, on the move, at work) and in which context (spare time, journey, work, daily activities, sport) the search scenarios would be applied. Figure 4 shows that five of the scenarios (*Car*, *Table*, *Item*, *Water*, *Place*) are more frequently used from home. Searching at work occurs rarely. As already pointed out earlier, this might be due to the small number of participating employees. This conjecture is supported by looking at the search context (Fig. 5). Leisure activities and journeys/trips

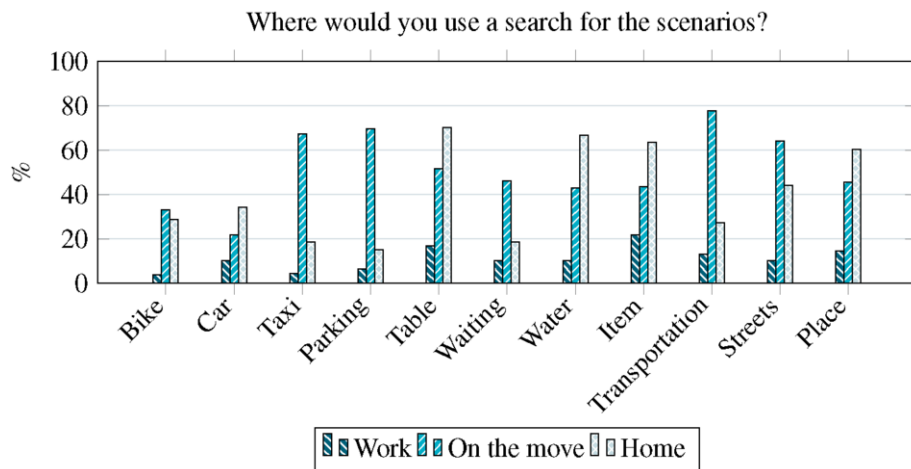

Figure 4. Results for question about usage place.

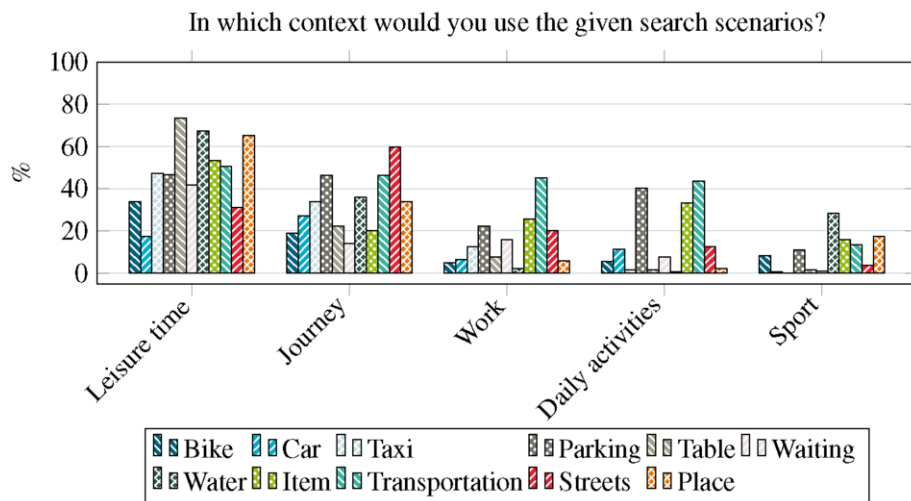

Figure 5. Result for question about search context.

are the most frequent situations to perform a search, each being more than twice as frequent as in other contexts.

The last two questions are related to time. First, we wanted to know at which times of the day search scenarios are applied (Fig. 6) and second, how often scenarios are performed at all (Fig. 7). For search scenarios such as *Item* and *Transportation*, the frequency is approximately uniformly distributed over the day while, e.g., *Taxi* and *Table* are at least three times more frequent in the evening than at any other time of the day. The frequency distribution in Figure 7 shows that many scenarios are never used. However, we believe that people may realize the comfort of such search scenarios, accept the technology incrementally, and adapt their behavior as with other technical innovations such as location-based services, Facebook, or the personal computer.

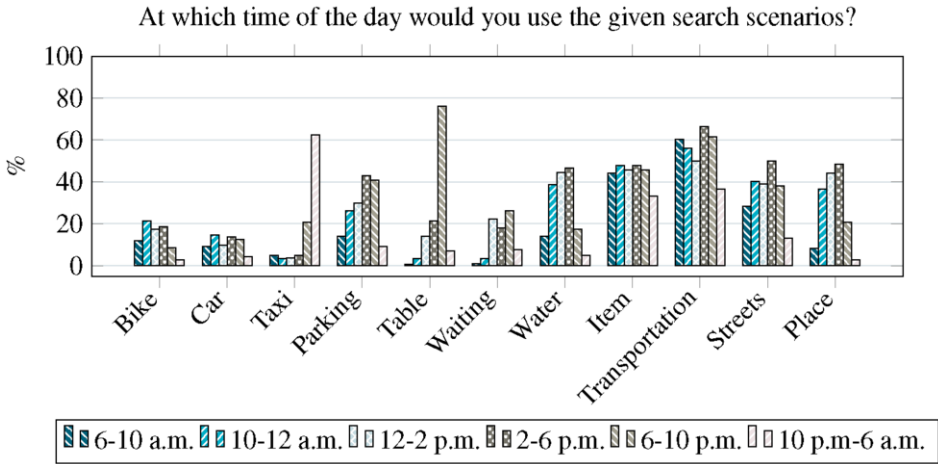

Figure 6. Result for question about the usage time.

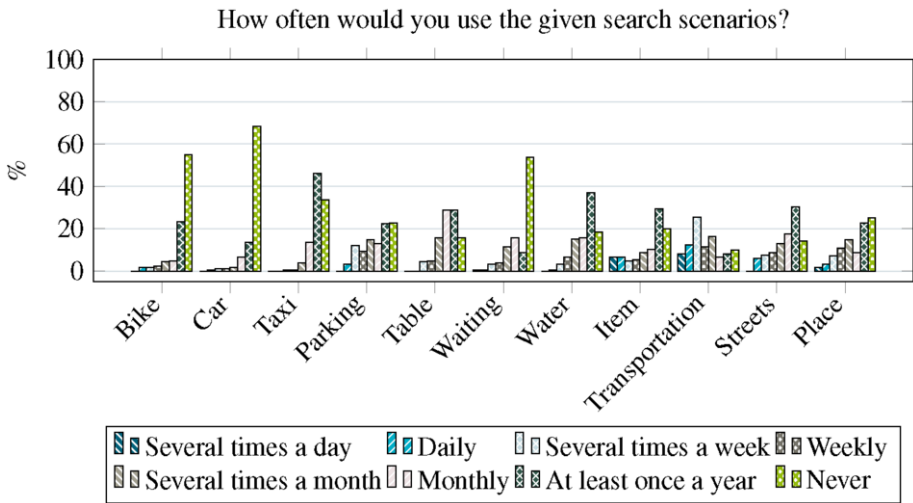

Figure 7. Result for question about the usage frequency.

Conclusion The results allow the conclusion that there is no single device or context which is mainly used but is strongly dependent on the search scenario. Thus, as mentioned in section 2.2, several characteristics of different devices and contexts need to be taken into account when designing a *Smart City Search* service.

Also, one can exploit the changing workload of sensors in the different scenarios. Take the *Table* scenario where nearly 80% of search requests are in the evening and assume there are only few state changes. Instead of contacting the sensor for each new user query, the sensor should push his state changes to the server. Contrary, if there a lot of state changes nobody or only a few users are interested in, the state can be pulled by the server whenever needed. Thus, the number of messages between sensor and server can be reduces, resulting in lower resource consumption.

2.4. How Do Participants Expect Their Results to be Presented? – Search Result Presentation

The last question block of the survey, *ResultQ*, is about how search results should be presented to the user. This includes the number of results to display, the information to show, the sorting of results, and the granularity of the state of the entity.

When it comes to the number of results on the first result page, most of the participants (77.14%) want to have ten while only 8.57% want 100, 7.43% three, and 6.86% all results. This outcome supports the approach taken by several existing sensor search systems and techniques such as Sensor Ranking [4] which try to find only a subset of matching sensors to reduce resource consumption in terms of bandwidth and energy. If more results are needed, these can be retrieved incrementally. Thus, if a user is satisfied with search results on the first page, unnecessary communication for further result pages can be avoided. Still, the question remains which information a user wants to be satisfied with the results.

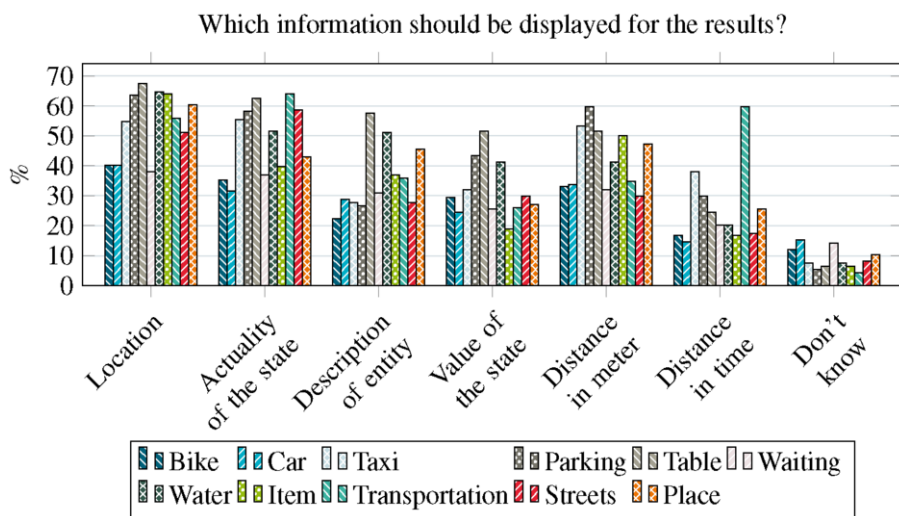

Figure 8. Results for question about the result information to display.

In Figure 8 it is shown which information users wish to see for the scenarios. Multiple answers were allowed. Although the maximum fraction of participants who request a specific piece of information is slightly above 60%, each requested piece of information is desired by at least 15% of participants. Interestingly, the *Actuality of the state*, i.e., the time since the last reading of the sensor, is in all scenarios one of the most important pieces of information. Thus, it can be assumed that users are aware that states of real-world entities can change very frequently and the older a value is, the more useless it is for the user. Consequently, it is important to have a recent sensor reading. If this is not available due to the knowledge that the state of the searched sensor is only changing rarely, an explanation of this fact should be displayed to the user.

Figure 8 shows that also the value of the state is important information for the user which leads to the question how this value should be represented. In Section 2.1 we introduced four classes of scenarios. Moreover, search results in each class share a common

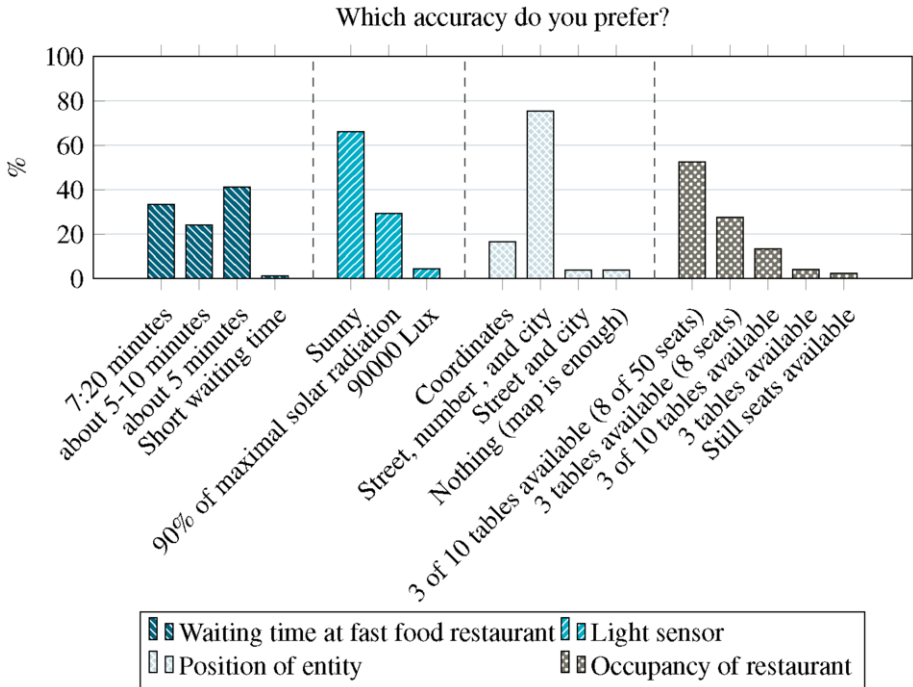

Figure 9. Results for question about the accuracy of states.

data type. The *waiting time* class has a result data type specifying time, the *availability* category has a Boolean or numeric result data type representing the number of units left, the *location* one has an address or relative or abstract position result data type, and the *state* class can have text or numeric result data type. We asked the participants which accuracy they would like to have displayed for different kinds of sensors respectively search scenario classes. The results can be seen in the plots in Figure 9. While the participants prefer an abstract state for a light sensor, they want the most detailed information for the occupancy of the restaurant. For the waiting time there is no favorite granularity. Finally, the position of an entity should be, in addition to a map, given as a fully qualified address and not as abstract coordinates in terms of Latitude and Longitude.

The sorting criteria for the scenarios was the last, multiple answer, question of this block. Figure 10 shows the results. The most important factor for users is the distance, either in meters or in time units. Especially the time until the next public transportation arrives sticks out. This can be explained by the annoyance of students about the local public transportation which is quite unreliable. The ratings of the searched entity or the neighborhood it is located in are not primary measures. Similar to the question about which information should be displayed the freshness of the state is also an important factor for the user.

Conclusion By incrementally searching for results instead of fetching all at once, the consumed resources in the backend, especially on sensor level, can be reduced, supporting approaches such as Sensor Ranking [4].

The desired accuracy for states shows that one needs flexible mechanisms in the backend to truncate or aggregate sensor values or to generate high-level states from raw

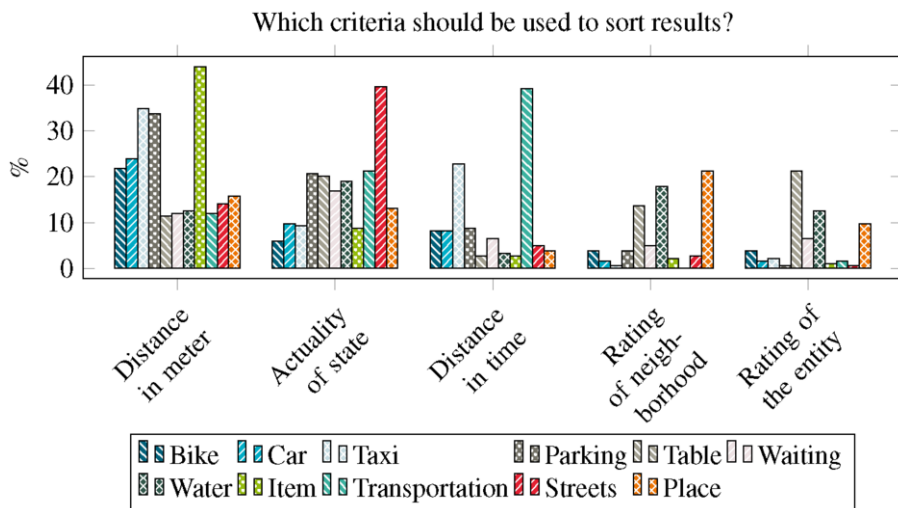

Figure 10. Results for question about result sorting criteria.

readings. This can in turn reduce the required resources because updates of high-level states are less frequent than changes in underlying sensor values as we have shown in [5].

Finally, the freshness of the state is one of the most important factors. Hence, it should be taken advantage of caching and algorithms which adaptively switch between pull- and push-based state dissemination. Users should be informed not only about the time since the last update, but also about the confidence in a displayed sensor state.

3. Related Work

The myGander [6] system is a search engine for mobile phones which allows to search for real-world entities such as a thrill ride in a amusement park. A query can have constraints like "waiting time < 20 minutes" and relevance metrics such as wait time and distance. A user study with twelve participants revealed that most users liked a real-time search. However, the small number of participants and the restriction of examining the satisfaction with the existing system does not allow to draw general conclusions for the design of a sensor search architecture.

Guinard et al. [7] also carried out a user study, but from the developer's side. They asked 69 novice software programmer to implement a mobile phone application which retrieves sensor data both via a RESTful interface and a WS-* service. On the one hand, developers preferred REST because it was easier to learn. However, for applications with QoS and security requirements WS-* services favored. Anyhow, our user study focuses on the user perspective rather than on the developer perspective.

The IoT comic book [3], which partially inspired our search scenarios, describes different possible future Smart City scenarios in an understandable, enjoyable way. Because it has been designed for a broad non-professional audience, it does not give any development hints or research directions.

4. Conclusion and Future Work

The Internet of Things slowly becomes reality. This trend enables new services and applications. We argued that one important service will be *Smart City Search* where users can find real-world entities with a certain state. To understand how people would use such a service, we conducted a survey with over 40 questions, discussed the results and gave advice for the design of the user interface and backend, i.e. the server and sensor software, of a sensor search architecture.

There is a need for a flexible, open system to allow applications for several device classes. Furthermore, the backend must support mechanisms to conserve energy in resource-limited devices such as smartphones and wireless sensor nodes. Finally, the complete development process should be user-centric, i.e. one has to carefully deploy, explain, and give insights into the working of sensor systems in a way that allows users to get familiar with these new technologies to build up trust in them. Otherwise, with closed, black-boxed systems, users will be anxious and suspicious of sensors tracking their activities.

Based on our previous work and the outcome of this survey we intend to build a sensor search system with interfaces optimized for mobile apps and powerful web apps. Additionally, an API to the search service will allow to build other applications on top. In the backend we will exploit Sensor Ranking and adaptive algorithms to reduce resource consumption on sensor level.

Acknowledgment

We would like to thank all participants of the survey. Special thanks goes to Lukas Ruge and Nina Hoppen for testing the survey and giving helpful feedback.

References

- [1] A. Caragliu, C. Del Bo, and P. Nijkamp, "Smart cities in europe, 2009," in *3rd Central European Conference in Regional Science*.
- [2] L. Ruge, B. Altakrouri, and A. Schrader, "Soundofthecity - continuous noise monitoring for a healthy city," in *5th International Workshop on Smart Environments and Ambient Intelligence (SENAmI 2013) at IEEE International Conference on Pervasive Computing and Communication (PerCom 2013)*, (San Diego, California, USA), March 18-22 2013.
- [3] M. Presser, ed., *Inspiring the Internet of Things!* Alexandra Institute, 2011. http://www.alexandra.dk/uk/services/Publications/Documents/IoT_Comic_Book.pdf.
- [4] B. M. Elahi, K. Römer, B. Ostermaier, M. Fahrmaier, and W. Kellerer, "Sensor ranking: A primitive for efficient content-based sensor search," in *IPSN 2009*, IEEE Computer Society, 2009.
- [5] R. Mietz, S. Groppe, K. Römer, and D. Pfisterer, "Semantic models for scalable search in the internet of things," *Journal of Sensor and Actuator Networks*, vol. 2, no. 2, pp. 172–195, 2013.
- [6] J. Michel, C. Julien, J. Payton, and G.-C. Roman, "The gander search engine for personalized networked spaces," tech. rep., Technical Report TR-ARiSE-2011-008, The University of Texas at Austin, 2011.
- [7] D. Guinard, I. Ion, and S. Mayer, "In search of an internet of things service architecture: Rest or ws-*? a developers perspective," in *Mobile and Ubiquitous Systems: Computing, Networking, and Services* (A. Puiatti and T. Gu, eds.), vol. 104 of *Lecture Notes of the Institute for Computer Sciences, Social Informatics and Telecommunications Engineering*, pp. 326–337, Springer Berlin Heidelberg, 2012.

Pedestrian navigation and shortest path: Preference versus distance

Iro ARMENI¹, Konstantinos CHORIANOPOULOS
Ionian University, Corfu, Greece

Abstract. Contemporary digital maps provide an option for pedestrian navigation, but they do not account for subjective preferences in the calculation of the shortest path, which is usually provided in terms of absolute distance. For this purpose, we performed a controlled experiment with local pedestrians, who were asked to navigate from point A to point B in a fast manner. The pedestrians' routes were recorded by means of a GPS device and then plotted on a map for comparison with suggested itinerary from a digital map. We found that the preferred shortest path is significantly different to the suggested one. Notably, the preferred paths were slightly longer than the suggested, but there was no effect in the trip duration because there were fewer obstacles, such as cars. Since many pedestrians employ GPS enabled devices, the findings of this research inform the development of mobile applications and the design of new subjective map layers for city dwellers.

Keywords. GPS, map, pedestrian, shortest path, preference, collective, experiment

1. Introduction

Contemporary digital maps are very elaborate and contain detailed information, but they lack meaningful knowledge in terms of collective habits. They might depict a technocratic instance of the real world, but their philosophy is car-driven, excluding anthropocentric features, which mainly characterize pedestrians and their behavior while walking through the city. In particular, digital maps may provide navigation functionality, but they do not account for subjective preferences in the calculation of the shortest path. It is common sense that pedestrians select shortest paths by considering multiple criteria, such as safety, traffic, weather, season, levels of noise, and accessibility, but contemporary digital maps only account for distance travelled.

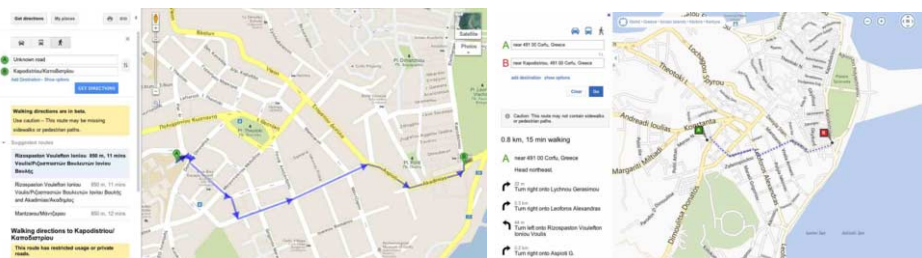

Figure 1. Digital maps provide efficient shortest path, but is it the preferred one by locals?

¹ Corresponding Author: Iro Armeni, Ionian University, Greece. Email: iroarmeni@gmail.com

Moreover, we have been inspired by the following quote (Stilgoe 1998): “Outside lies unprogrammed awareness that at times becomes directed serendipity. Outside lies magic.” With that in mind, our research question gets shaped: “Could we take advantage of highly precise technology (e.g., GPS, digital mapping), in order to create a more humane cartography (e.g., subjective maps)?” In this work, we are validating the feasibility of this idea by performing a controlled experiment, which provides sufficient data to create a new type of map for city dwellers. In the future, we propose the design of digital map layers from pedestrian GPS traces, in order to provide maps that are tailored to the actual preferences of city dwellers.

2. Methodology

Since many pedestrians employ GPS enabled devices, e.g., smart phones, we propose the anonymous collection and analysis of their GPS traces, in order to explore their actual preferences and design the respective map layers. For this purpose, we performed a controlled experiment with ten local pedestrians, who were asked to navigate from point A to point B in a fast manner. The pedestrian routes were recorded by means of a GPS device and then plotted on a map for comparison with existing pedestrian navigation applications.

2.1. Subjects

Users’ compliance with certain criteria allowed the collection of a clean data-set and the minimization of incorrect assumptions regarding the selected routes. In particular, the ten participants enjoy and have a habit of walking around the city, have a good knowledge of the city’s streets, are healthy and capable of walking a medium distance, and are adult (18+) but not more than 50 years old. It was essential for the user to have lived and experienced the experiment's location area, since local knowledge is the source to derive from and depend on, in order to re-examine pedestrian navigation systems and to re-establish the pillars of their foundations.

2.2. Procedure

A specific outline of user behavior was also constructed, based on which participants made decisions according to their free-will and basic guidelines. After taking into consideration space, time, walkability and various alternatives of their combinations, points A and B (starting and finishing points of the trajectory) were decided. Main criteria of their selection were a) the variety of connecting paths able to be generated between them and b) the possibility of creating a specific scenario. The destination point is within a 750 meters radius from point A, thus pertaining to the 800 meters – 10 minutes’ walk, considered as a medium walkability radius in neighborhoods. The in-between topography is slightly steep, mainly towards point B; depending on the chosen path the inclination differentiates. The landscape is that of a provincial town’s urban context and includes a variety of sceneries; streets of high, low or no traffic, traffic lights, pavements of larger or narrower section, trees, shopping

streets, pedestrian zones and promenade by the sea are possible alternatives, which combination is closely related to the participants' choice.

For the experiment's requirements, ten subjects were asked to walk from point A to point B, according to the following guidelines: They had to follow the fastest path in a time frame of 13 minutes maximum, having in mind that they are supposed to move quickly, efficiently and do not stall. The duration of the task was defined by taking into consideration the suggestions of popular navigation applications in relation to the proposed route connecting A to B, which was reported to be eleven minutes by the Google Maps pedestrian option.

Having set the starting and finishing point of the trajectories, a plausible navigation scenario was then created. Its importance was motivated by the need to successfully control the experiment by involving participants in a common task. The scenario encouraged fast movement: "You are a student at the local University and today is your/the graduation day. The ceremony starts at 11:00 and you are supposed to be there at least 15' minutes earlier. Although it was a day you were not supposed to be late, due to several unforeseen incidents you found yourself being at the Department's Secretary on 10:30. Hence, you have approximately 13 minutes to arrive on time for the graduation ceremony."

Users were handed a GPS-enabled device and were informed about the process and their role; they were expected to complete the task in 13 min for the fast track. When back to point A, the device was returned to the organizers and participants were asked to fill out a related to their previous experience questionnaire.

2.3. Measuring instruments

The experiment's structure was determined after performing a pilot version. During that stage, time limitations, users' compliance to the dictated instructions and reasoning of preferences took place, thus forming the final layout. On the pilot's findings was the questionnaire based on; the participants' opinion of their route selection presented many similarities and on these majority points were the following questions developed on. Their purpose was to assess the choices, so as to understand the way pedestrians behave in a certain context, under specific conditions, and reach an outcome in respect with their preferences. These results were used as the background while creating the new pedestrian-friendly layer-map.

The questionnaire measured on a 5-point Likert scale (from strongly disagree to strongly agree) the following: I chose, on purpose, a fast track: a) that would permit to walk in a quick pace, b) that a car would follow if moving from A to B, c) where less car traffic is expected, d) where less people are expected.

A final task followed by the completion of the questionnaire, which involved tracing the previously followed tracks on a printed map by the participants and answering whether they would choose to follow the same paths if asked to retake the experiment. This step was inspired by the work of Lynch (1960) and it allowed us to draw conclusions regarding the participants' perception of the city in relation to map illustration.

Last, but not least, the pedestrian routes were recorded by means of a GPS device and then plotted on a map for comparison with existing pedestrian navigation applications.

3. Results

Out of the 10 users we analyzed 7 trajectories, because the rest have performed longer durations than the required due to unforeseen circumstances, e.g., chance meeting with an acquaintance. The acquired GPS and questionnaire data were analyzed and combined to produce results regarding to users' preferences and selections. In brief, we found that the perceived shortest path is significantly different to the one suggested by a navigation application.

Table 1 Overview of the preferred shortest paths (The suggested one by Google Maps is 11min, 850m)

User	Duration (min:sec)	Distance (km)	Avg speed (km/h)	Avg elevation (m)
11	9:23	1.15	7.36	17.24
10	13:30	1.08	4.79	16.49
9	10:50	1.01	5.60	17.74
8	9:54	1.0	6.07	23.20
7	11:00	0.97	5.29	22.27
6	11:40	0.91	4.68	22.10
5	8:40	1.02	7.09	10.95

The paths that users chose to follow while quickly moving from point A to B demonstrate variety and extended divergence from the suggested trajectory, as proposed by a popular map application. In terms of distance, participants' choices are longer by 50 or more meters, but in terms of time they achieved faster scores. The results clearly expose the computational and pure mathematical reasoning behind the suggestions of the application, in contrast to the multifactorial thinking of human beings. Distance is not the only parameter to consider; the questionnaire results show that factors such as less crowded streets or streets of less traffic are also included in the equation. Delays, as a consequence of lack of pavements or obstacles attributed to moving or parked cars, become considerably absent. Thus, computerized perception of pedestrian navigation can be out of track, since minimum distance does not always signify the fastest or safest choice. It is noteworthy that the application's suggestion goes along main roads of heavy traffic and noise, and although quite large pavement zones are provided for most of the path, it was not the primary selection of users.

The above findings are interpreted as pedestrians' behavior; their choices were based on personal experience and opinion. In an urban fabric, users evaluate conditions, preferences and circumstances and navigate accordingly. Although weather, season and time of day do not appear to play an influential role, we believe it is due to the good conditions under which the experiment took place that contradictory results were not acquired. If the experiment took place in a longer period of time, throughout the year and day, it is expected for those three factors to become essential. In addition to the answers and GPS data, the hand-drawn traces of the followed paths are of high interest, since a small amount of participants was partially mistaken, which could indicate a difficulty to link visual experience of streets to map-illustrated ones.

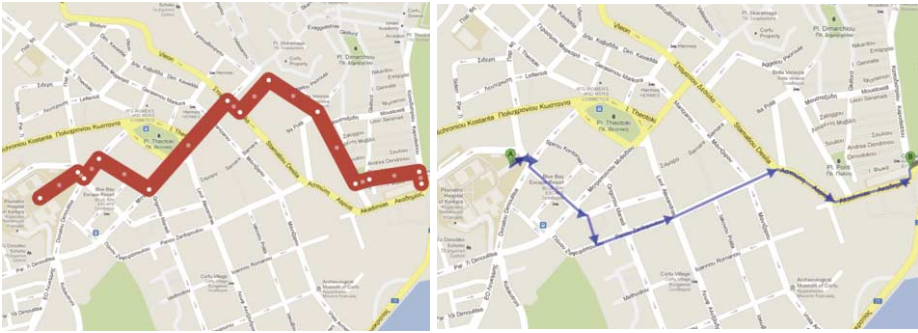

Figure 2. The collectively perceived shortest path is significantly different to the suggested one.

It becomes evident that a pattern emerges from these results; users tend to choose similar sub-paths not because there are not any alternative ways to move, but rather because they appraise the same urban qualities as important.

4. Discussion and Further Research

The notion of significant differences between perceived and actual use of information technology has been documented in contemporary usability research. Indeed, Nielsen and Levy (1994) have highlighted that the perceived usability might not be correlated to the actual efficiency of an information technology, in other words, sometimes people found more usable something that is slower. Moreover, Frøkjær et al. (2000) have found that usability has a complex dependency on efficiency, effectiveness, and satisfaction. Similarly, the main finding of this work is that the widely available shortest path functionality for pedestrians might not provide subjectively optimal results, at least in the case of urban centers with a complex set of available paths. The findings of this research inform the development of mobile applications and the design of new map layers for city dwellers. They serve as the raw data to inform the learning process for the creation of pedestrian-friendly maps.

Previous research has considered the analysis of GPS traces and the design of new types of digital maps separately. The analysis of GPS traces has been elaborated by Zheng et al. (2009), who have collected and data-mined a large data-set of trajectories, in order to find out interesting places, means of transportation, and travel habits. More recently, they have extended their research to provide social recommendations based on the itinerary habits of locals. Nevertheless, they have not examined the requirements for constructing new types of digital maps and they have not considered pedestrians. On the other hand, the design of maps has been elaborated by the MIT Senseable City group. Chen, X. (2011) created isochronic maps based on the time required to travel by public transportation. Our work is building upon those efforts by providing an integrated view of mining GPS trajectories and creating new types of digital maps.

Former subjective approaches to urban informatics have considered maps as a platform, but then have not explored how maps themselves could evolve as part of the collective local knowledge. For example, Ringas et al. (2011) have found that citizens are benefited by public sharing of personal stories in various formats (text, voice, photo, video). Moreover, Traunmueller et al. (2013) have focused on suggesting alternative leisure paths through social media voting. Nevertheless, the above works assume an

extra effort on behalf of the user to share their story and they have not yet considered the potential crowdsourcing of the subjective data on a collective image of the city.

In addition to the research efforts, there have been several grass roots initiatives. For example, the biketastic community has been uploading bike routes in order to facilitate the sharing of safe and enjoyable routes for bikers (Reddy et al. 2010). Although, the biketastic system has similar motivation and approach, our work is also considering the visualization of path information in a way that is accessible to pedestrians. Moreover, the controlled experiment procedure is providing cleaner data and the opportunity to examine the subjective motives behind route preference.

In ongoing research, we are designing a dynamically crowdsourced mobile map application where the most frequently used streets will be illustrated and dynamically modified, according to users' feedback; most popular streets will appear as of larger cross-section, whereas less popular ones of narrower. Dynamics will not only be controlled by frequency, but also by personal preferences, depending on occasion: weather conditions, time of day, possible health problems, etc. will generate paths tailored to the user's specific demands and safety. These maps' priority will be the pedestrian and the biker and will be addressed to all people, either locals or visitors.

References

- [1] Chen, X. (2011). Seeing differently: cartography for subjective maps based on dynamic urban data (Master thesis, Massachusetts Institute of Technology).
- [2] Frøkjær, E., Hertzum, M., & Hornbæk, K. (2000, April). Measuring usability: are effectiveness, efficiency, and satisfaction really correlated?. In Proceedings of the SIGCHI conference on Human factors in computing systems (pp. 345-352). ACM.
- [3] Lynch, K. (1960). The image of the city (Vol. 1). MIT press.
- [4] Nielsen, J., & Levy, J. (1994). Measuring usability: preference vs. performance. Communications of the ACM, 37(4), 66-75.
- [5] Ringas D., Christopoulou E., Stefanidakis M., "CLIO: Blending the Collective Memory with the Urban Landscape", International Conference on Mobile and Ubiquitous Multimedia 2011, 7-9 December, 2011, Beijing, China
- [6] Sasank Reddy, Katie Shilton, Gleb Denisov, Christian Cenizal, Deborah Estrin, and Mani Srivastava. 2010. Biketastic: sensing and mapping for better biking. In Proceedings of the 28th international conference on Human factors in computing systems (CHI '10). ACM, New York, NY, USA, 1817-1820.
- [7] Stilgoe, J. R. (1998). Outside Lies Magic: Regaining History and Awareness in Everyday Places.
- [8] Martin Traunmueller, Ava Fatah gen. Schieck, Johannes Schöning, and Duncan P. Brumby. 2013. The path is the reward: considering social networks to contribute to the pleasure of urban strolling. In *CHI '13 Extended Abstracts on Human Factors in Computing Systems* (CHI EA '13). USA, 919-924.
- [9] Hyoseok Yoon, Yu Zheng, Xing Xie, Woontack Woo: Social itinerary recommendation from user-generated digital trails. *Personal and Ubiquitous Computing* 16(5): 469-484 (2012)
- [10] Yu Zheng, Lizhu Zhang, Xing Xie, and Wei-Ying Ma. 2009. Mining interesting locations and travel sequences from GPS trajectories. In Proceedings of the 18th international conference on World wide web (WWW '09). ACM, New York, NY, USA, 791-800.

The Future of Local Memory Websites as Empowering Niches in Amsterdam

Mike de KREEK^{a,1} and Marijke OOSTERBROEK^b

^a*School of Social Work, Amsterdam University of Applied Science*

^b*E-Culture, Amsterdam Museum*

Abstract. In this article, we explain how we envision the further interconnection of existing initiatives of online local memory collecting into a new social infrastructure, that is beneficial to the whole of Amsterdam. Three examples of local memory websites show how large districts in the East, South and West are represented thoroughly by local residents, in spite of differences in organizational characteristics. The concept of empowerment, as a multilevel construct, lends itself to frame these examples as important building blocks of socially sustainable districts and neighborhoods. Local knowledge, experiences and people become connected across Amsterdam when local memory websites become interconnected, by introducing city-wide compelling themes. Discussing this social infrastructure in relation to the concept of smart cities, leads us to a plea for more research focus on *sociably* smart cities.

Keywords. digital memories, community memory, cultural citizenship, community capacity, empowerment, community informatics

1. Introduction

In Amsterdam, we have seen the emergence of small and large local memory websites since the year 2000, just like in many other cities [1][2]. Local memory websites are online spheres where residents collect their memories about places or experiences in their neighborhoods. One such example is the ‘Memory of East’ project². As part of an online and offline exhibition on Amsterdam East, the Amsterdam Museum trained neighborhood residents to collect memories of local everyday life. Some volunteers interviewed residents and others went to group meetings to collect stories together. After the exhibition closed in 2003, an active group of volunteers notified the museum that they wanted to continue collecting memories to present them online, which they continue to do to the present day [3]. Large self-organizing community groups like this, are also found around the ‘Memory of West’³ and the ‘Memory of District South’⁴.

In order to unravel our vision of how these initiatives can contribute to a sociable smart Amsterdam, we first offer some insight into the organizational and participative characteristics of these examples. In the second section we show how an earlier

¹ Corresponding Author: Mike de Kreek, Amsterdam University of Applied Science, Wibautstraat 80, 1091 GP, Amsterdam, The Netherlands; E-mail: m.de.kreek@hva.nl.

² <http://www.geheugenvanoost.nl>.

³ <http://www.geheugenvanwest.nl>.

⁴ <http://www.geheugenvanplanzuid.nl>.

literature review [4] of studies on local memory websites resulted in three levels of analysis that neatly fit in the empowerment paradigm: a micro level describing individual benefits, a meso level of effects for larger groups and a macro level strengthening local community. Finally, we discuss a daring experiment with a city-wide theme that taught us how to take the next steps in connecting these initiatives naturally, building a new layer of social infrastructure.. We conclude by discussing this layer in relation to the concept of smart cities.

2. Three Times a ‘Memory of ...’

In the context of a longer tradition of trying and succeeding to reach new target groups and city neighborhoods, the Amsterdam Museum began with the preparations for its first neighborhood exhibition ‘East, a neighborhood in Amsterdam’ in 2001. In addition, the museum wanted to develop this exhibition in cooperation with the residents living in the neighborhoods. In order to have access to their stories, the museum started the ‘Memory of East’ project (see Figure 1). The museum cooperated with a local welfare institute with an interesting network in the neighborhood, because it hosted computer locations where residents could learn software and internet skills.



Figure 1. The Memory of East.

The following aims were formulated: “improving social cohesion and accessibility, increasing skills and helping people to become better acquainted with art and culture, as well as the history of Amsterdam” [3]. As we have mentioned in the introduction the residents either interviewed others or collected stories together. In addition they could choose their own topics, as long it had something to do with their neighborhood. The memories could be about yesterday or 80 years ago and most were from everyday

personal life. In 2010 the museum handed over the organization to a group of local residents, who are still in control. Today, the website contains more than 2.500 memories consisting of mainly text (350 words) with images and 22.000 comments which often also contain memories. The website attracted approximately 200.000 visitors in 2012 [5].

The ‘Memory of West’ initiative was inspired by the Memory of East, which is why it contains many similarities, but also some differences (compare Figure 1 with Figure 2). It was initiated in 2004 by the local government of the western city district and set up together with cultural heritage professionals [6]. Among the aims were: preventing isolation of elderly people, strengthening of self-confidence, increasing tolerance and improving social cohesion. Residents interviewed other residents and some people wrote down their own memories. In the first phase of the Memory of West, journalistic-style memories had more focus than in the later years. In 2007 the Memory of West became an association in order to become more independent and to be able to apply for subsidies elsewhere. Today, the website contains more than 1.600 everyday life memories, but also a number of ‘reporter stories’ about the present. It attracted about 87.000 visitors in 2012 and since the start more than 8.000 comments were posted.



Figure 2. The Memory of West.

A rather different case is the ‘Memory of District South’ which was initiated by a resident in 2003 (see Figure 3). After a couple of years and a few hundred stories it became an association, because of its success. The website is financed by donations and aims to draw attention to history of the area with respect to arts, architecture, city development and the persecution of Jews in WW II. There are many factual items on the website about these topics, but also more than 500 memories, 50 digital memorials

and about 1300 comments. Most memories are written from personal memory and sent in by local residents. The website attracted about 65.000 visitors in 2012.



Figure 3. The Memory of District South.

Although Amsterdam has many, smaller initiatives, the ones that we have introduced here give some insight into their possible backgrounds and scope.

3. Local Memory Websites as Empowering Niches

From the aims mentioned in the previous section one can see that the expected effects manifest themselves on different levels. That is to say, learning computer skills has no obvious relation to, say, improving social cohesion. Or does it? A systematic literature review of studies on interventions with local memory websites, has recently shown that the broad range of effects attributed to these interventions, fit perfectly with the widely accepted notion of empowerment as a multilevel construct [4]. As such it has as micro (individual), meso (group) and macro (community) levels, which also influence each other [7]. The possible effects on these levels of analysis are shown in Figure 4.

Local memory websites can be seen to empower on three levels. For the purpose of the present paper we focus on the macro level, which is why we briefly mention the micro and meso level. Empowerment is sometimes used in the context of what we call direct benefits for individual participants – the micro level –, e.g. the development of technical skills or the growth of self-confidence. At other times the term is related to middle range concepts such as the inclusion by increasing the online presence of a certain underrepresented group elderly people – the meso level. And finally, the growth of power is articulated with three concepts at the macro level: community memory, cultural citizenship and community capacity.

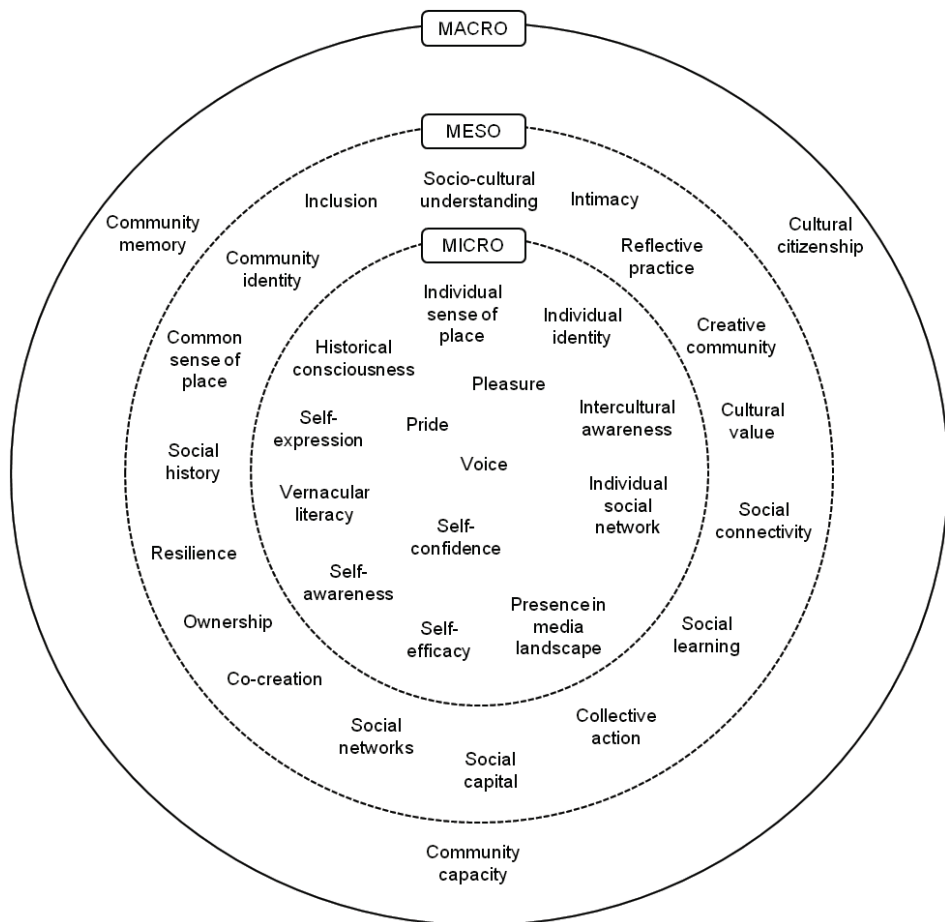

Figure 4. Empowering effects on three levels of analysis.

Firstly, in the construction of community memory, residents present their own view on local knowledge online and by doing so they influence how their surroundings’ past and present should be represented for future use. A strong example is the attention drawn to personal memories of Jews being deported from their houses in some neighborhoods during WW II. These views do not replace the professional historical interpretations, but extend the available reservoir of text and interaction about a certain locality, which, in turn, leak into collective memory. In addition, this is a self-enforcing collective process, because these views are easily distributed online, and at the same time their authentic character invites other residents to participate in this process [8].

Secondly, as a practice of cultural citizenship, people find online environments in which they creatively express their experiences and opinions within the local culture. The Memory of East, for example, contains a large number of popular socially critical poems. Next to commercial popular culture and institutional discourses, these environments form an independent growing cultural public sphere where meanings in life are negotiated and cultural value is judged by ordinary people [9].

Thirdly, with respect to community capacity, community members share memories and experiences in new online social networks, through which they create their own discourse in favor of future collective action. If we return to the example of the Jews in WW II, it is not hard to imagine that the resulting discourse contributes to a more or less latent collective action of resistance to let processes like that ever happen again. Again, this does not necessarily replace community building professionals attempting to contribute to social cohesion, although it does influence their work, because it may shift towards facilitating a co-creative community [10].

These examples show that the empowerment paradigm with its three levels of analysis can be an overall framework for analyzing and framing the effects of local memory websites. In addition we can see that the use of new media tools and the Internet is an important driving force in the involved empowering processes. More specific, the use of online environments seems to provide the continuity in access related to the effects on meso level and especially on the macro level where past, present and future become connected. When the digital memories that we create in the present “result from a combination of recall and desire, which in turn are incentives to remodel our past and fashion our future” [11], they need to be available for interaction in the future.

4. City-wide Themes as Ripples in the Pond

In 2009 the Amsterdam Museum initiated a project about the changing identity of neighborhood shops in the city. Once, these shops were places for conversation and social control, but more and more big supermarkets lowered their viability and new forms of entrepreneurs and public spheres had to be discovered. A memory website, the ‘Corner Store’⁵, was developed, based on the other memory websites, but this time covering several city districts, instead for a single neighborhood community (see Figure 5).

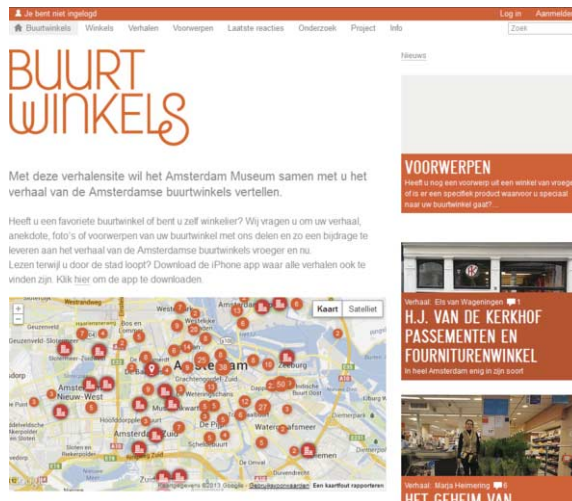

Figure 5. The Corner Store website.

⁵ <http://buurtwinkels.amsterdammuseum.nl>.

Participants of the local memory websites such as the Memory of East and the Memory of West were eager to collect memories for the new project as well. These could be their memories of long-gone shops or those of the shop owners. In addition, students of the University of Amsterdam researched to development of neighborhood shops, the results of which also were published on the website. Exhibitions based on all this content were organized not just in the museum, but also in two temporary local museums in the east and the north of Amsterdam.

On the first hand, the Corner Store project taught us to some important lessons [12]. First, the professionals and the involved residents did not have a shared authority with respect to decisions on a range of aspects. Second, the exhibition remained an exclusive part of the project and not a co-creative final product. Third, it was not clear whether the website would remain open for new contributions after the project finished. On the other hand, the project was considered as a good practice, because a city-wide theme was picked up by various participants with different backgrounds and ages, and from many districts of the city. At the same time, the introduction of a compelling city-wide theme strengthened the individual communities, because this gave them a temporary new collective incentive. These lessons learned – both negative and positive – merged into the idea of creating the ‘Digital Heart of Amsterdam’⁶, a community where all participants of different memory projects could keep on meeting and sharing experiences [13] (see Figure 6). Moreover, the other memory projects became interconnected there, while safeguarding their unique local identity.



Figure 6. Digital Heart of Amsterdam.

Although the first ideas emerged in 2008, it is today that we can concretely envision the near future of local memory websites in Amsterdam as a flower with

⁶ <http://hart.amsterdammuseum.nl>.

petals that are connected to the floral axis which consists of the Digital Heart of Amsterdam (see Figure 7). The petals represent the various larger and smaller, independent local memory websites in different districts and neighborhoods. They all have their own focus in their local memory collecting and activities related to them. The Memory of East and West are already connected, and we are involving the Memory of District South at this very moment. The initiatives in the North and in other directions will hopefully join at a later stage. The key persons will be present in the Digital Heart of Amsterdam as well, because that is where experiences and dilemmas with managing a local memory website are shared with peers. In cooperation with these key persons, the museum occasionally defines a compelling city-wide theme for which participants of the different initiatives are invited to collect memories. These stories are published in the local memory websites, while at the same time harvested – including their comments – by the Digital Heart of Amsterdam which functions as a kind of digital exhibition. Discussions around the theme in question on local level thus become connected with each other on a collective platform. In this way, part of the local empowering niches and their effects converge into a city wide place for empowerment on macro level. This replication of empowerment processes on different levels is visualized with the recursion depicted in Figure 7.

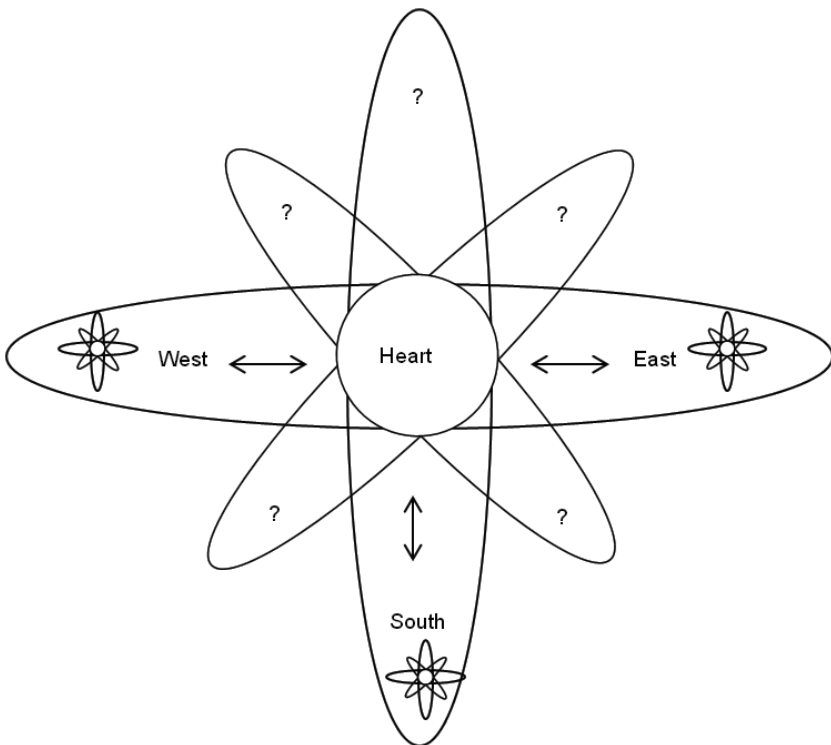

Figure 7. The flower showing recursive aspects with respect to empowerment processes.

5. Conclusions: Towards a Sociably Smart City

We have shown that collecting memories online contributes to empowerment processes at micro, meso and macro level. This relates in a specific way to what Garagliu et al. defines as a 'smart city' [14]:

when investments in human and social capital and traditional (transport) and modern (ICT) communication infrastructure fuel sustainable economic growth and a high quality of life, with a wise management of natural resources, through participatory governance.

The social infrastructure in which memories are shared in Amsterdam, expanded itself, once it found its way to the urban technological infrastructure. First, this expansion occurred at the neighborhood level facilitating novel connections between residents, but today it commences to stretch out over various city districts. In this process, the technological and social infrastructure mutually influence and drive each other's development. Creating, sharing and collecting digital memories in this new way, has many individual benefits on the micro level which raise the quality of individual lives. The kernel of this process is claimed to be that every personal memory of the past inhibits a wish of how the quality of future life should look like. A dramatic memory may imply a wish to prevent repetition, whereas a positive memory suggests a desire for similar future experiences.

When, in addition, the memory is a person's experience in his or her living environment, then the implicit wish may turn into a latent urge for action or a point of view with respect to that locality. On a collective level, more or less similar online memories, and comments on them, become clustered by keywords. Together they form a virtual public sphere where negotiation processes take place that contribute to an implicit collective wish with respect to certain issues or topics. This does not necessarily lead to immediate action, but might be considered as a collective point of view with an indirect but strong influence on the construction of what is considered to be good for the development of Amsterdam. This 'smartness' does not instantly fit in with the common concept of smart cities in which the discourse often contains words such as 'competition' and 'productivity'. In contrast, we would like to consider these softer aspects of smart cities as *sociably* smart, that is, closer to social sustainability than to economical sustainability. We plead for more focus in the smart city research on these sociable aspects and their relation to sustainability.

If the local memory websites are considered to be sociably smart in their being enabling niches for empowerment, then the question arises what their interconnection in the Heart of Amsterdam, through the city-wide themes, contributes to this. This contribution has two sides. The first one is that introducing such a theme brings an additional incentive for the local memory collecting communities which strengthens their constitution. The second contribution is that it adds another layer of possible empowerment to a sociably smart Amsterdam. However, how this manifests itself on an urban level is complex to explicate. With respect to the Corner Store project, among the most common and explicit readings are the following: 1) some people dislike the decrease of classic Dutch corner store, 2) some people disapprove of the increase of supermarkets, 3) some people like the increase of multi-cultural corner stores and 4) some people are not content with this latter development.

But these readings were provided by and described from the perspective of the involved institutions, such as the museum and the university, and not fed back into community in a way that facilitated ongoing dialogue. Moreover, they were not based on a systematic analysis of the memories and the comments contributed by residents. The result of this is, that we actually do not know what tendencies are hidden in the Corner Store data, or in other possible clusters of data across the local memory websites. Thus, an important next step would be, to apply text mining techniques to find patterns such as shared issues and collective processes that reveal the citizens perspective. Moreover, we would like to find ways in which these patterns directly inform and empower city inhabitants, instead of primarily the professional or scientific community. These wishes might become fulfilled, if we involve methodological insights from, the growing field of Digital Humanities [14].

References

- [1] Stillman, L., & Johanson, G. (Eds.). (2007). *Constructing and Sharing Memory: Community Informatics, Identity and Empowerment*. New Castle: Cambridge Scholars Publishing.
- [2] Ringas, D., Christopoulou, E., & Stefanidakis, M. (2011). Urban Memory in Space and Time. In G. Styliaras, D. Koukopoulos, & F. Lazarinis (Eds.), *Handbook of Research on Technologies and Cultural Heritage: Applications and Environments* (1 vol) (pp. 325–340). Hershey: IGI Global.
- [3] Ernst, M. (2006). East Amsterdam, an outreach project. In R. Kistemaker (Ed.), *City museums as centres of civic dialogue?* - Proceedings of the Fourth Conference of the International Association of City Museums (pp. 107–112). Amsterdam: Amsterdam Historical Museum.
- [4] Kreek, M. de. (2013). New directions in research on local memory websites. *Journal of Social Intervention: Theory and Practice*, 1(2), In press.
- [5] Eekeren, A. van. (2012). The Memory of East, a virtual community project - How some districts in the Eastern part of Amsterdam became a space of remembrance. In T. van Kessel, R. Kistemaker, & L. Meijer-van Mensch (Eds.), *City museums on the move* (pp. 31–33). Amsterdam: Amsterdam Museum.
- [6] Soolsma, B. (2010). *Storyhood – Een inventarisatie van vijf buurtverhalenprojecten en hun ontwikkeling van 1994 tot 2010 [An investigation of five local memory websites and their development between 1994 and 2010]*. Unpublished report: Amsterdam University of Applied Science.
- [7] Zimmerman, M. A. (2000). Empowerment Theory - Psychological, Organizational and Community Levels of Analysis. In J. Rappaport & E. Seidman (Eds.), *Handbook of community psychology* (pp. 43–63). Dordrecht: Kluwer Academic Publisher.
- [8] Kreek, M. de. (2011). Multilevel participation within on-line collections of local memories as a practice of cultural citizenship. *Digital Strategies for Cultural Heritage 2011*. Rotterdam: Digital Heritage Netherlands. Retrieved from <http://kennisbank.hva.nl/nl/record/445183>
- [9] Burgess, J. (2006). Hearing Ordinary Voices: Cultural Studies, Vernacular Creativity and Digital Storytelling. *Continuum: Journal of Media and Cultural Studies*, 20(2), 201–214.
- [10] Foth, M., Klaebe, H., & Hearn, G. (2008). The role of new media and digital narratives in urban planning and community development. *Body, Space & Technology*, 7(2). Retrieved from <http://people.brunel.ac.uk/bst/vol0702/>
- [11] Van Dijck, J. (2007). *Mediated Memories in the Digital Age*. Stanford: Stanford University Press.
- [12] Maris, M. (2011). *In de aabieding [For sale]*. Amsterdam: Amsterdam Museum.
- [13] Wildt, A. de. (2013). Community Websites: Linking the Personal to Urban History. *Journal of Museum Education*, 38(1), 3–8.
- [14] Caragliu, A., Del Bo, C., & Nijkamp, P. (2011). Smart Cities in Europe. *Journal of Urban Technology*, 18(2), 65–82.
- [15] Borgman, C. L. (2009). The Digital Future is Now: A Call to Action for the Humanities. *Digital Humanities Quarterly*, 3(4). Retrieved from <http://works.bepress.com/borgman/233/>

Helping Tourists to Plan Activities with Shared Urban Social Context

Andreas KOMNINOS^{a,1}, Peter BARRIE^a, Jeries BESHARAT^b

^a*Glasgow Caledonian University*

70 Cowcaddens Rd. Glasgow, G4 0BA, UK

^b*Computer Engineering & Informatics Department, University of Patras
Rion 26500, Greece*

Abstract. Ubiquitously available map-based services for tourism are becoming a norm, with the spread of smartphones and the integration of pervasive displays in the urban infrastructure. At the same time, interactions with the urban environment through social networks is rife, with actions such as tagging locations and checking-in to these now a part of mainstream mobile social network use. In this paper, we discuss how exploiting mined interactions with the urban environment can help tourists better plan activities, through sharing the collectively generated social context of a smart, connected city, as a background layer to mapped POIs.

Keywords. Social context, ubiquitous maps, tourism

Introduction

Visitors and tourists rely heavily on third party information relating to sights of interest, locations worth visiting and areas suitable for wandering around during different times. Traditional information sources for tourists include guidebooks and recently, community websites for travel. Websites such as Wikitravel and Trip Advisor reflect the subjective opinions of contributors. Even though on-line media are regarded as more collaborative and hence somewhat more likely to present a more accurate picture, Gretzel and Yoo [1] found that reviews therein play a much less significant role during planning, on determining “What to do, where to go and when to go” (just 32.5%, 27.7% and 26% of participants respectively, the most popular use of online reviews was for “Where to stay” with 77.9%). Just under half of online site users look for information from local destination (44.6%) and state tourism websites (29.7%), though these could be expected to more accurately reflect a local’s knowledge about what to see and do. White and Buscher [2] showed that relying on information from other tourists is probably not optimal. In their study, they discovered that non-locals tended to select worse quality experiences (restaurants) than locals. Hence the reviews likely to be shared on online websites for tourism do little to help tourists uncover hidden gems or get an idea of what is truly worth visiting.

¹ Corresponding Author: Andreas Komninos, Glasgow Caledonian University, Glasgow, UK. Email: andreas.komninos@gcu.ac.uk

What seems to be lacking from both guidebooks and community websites is the locals' experience of a place. As is evident, the sharing of local knowledge has large potential in helping enhance visitor experiences. Bearing in mind the difficulty in capturing this knowledge from locals and also sharing it, we discuss in the following sections a system able to automatically infer such knowledge by mining check-in data. Furthermore, we present an early investigation into the utility of this information for the in-situ planning of activities by tourists.

1. Representing context in maps

Past research in mobile location based services for tourism has led to the commercial offering of many map-based guides for visitors. Most such ubiquitous systems incorporate a mapping component, in which information filtering through context awareness plays an important role considering the limited screen real estate and the limited interaction time that users typically exhibit when using ubiquitous computing equipment [3]. Reichenbacher [4] discusses the need for relevance in mobile cartography by aligning it to objective and subjective dimensions. Objective dimensions include physical relevance (spatial and temporal) as well as system relevance (query and algorithmic relevance). On the other hand, subjective relevance rotates around a particular user's context, such as thematic interests, cognitive abilities, planned or current activity, task and goals.

The introduction of social media and the ability to mine users' interactions with these, through open APIs, yields the potential of the introduction of a previously unused type of context in ubiquitous cartography, that of social context. This type of context is composite and consists of user presence at a location (spatial), user interaction with this location through a social media network (something that signifies positive disposition) and time. The aggregation of this type of context from a multitude of users for a particular geographic area can be used to build a higher-level abstraction of social context that reflects collective behaviour, and thus can be considered to be part of the environmental context. Environmental context can play a significant role in adapting information for users, for example Nivala et al. [5] show how it can be used to filter displayed information for activities on a map, based on the current season of the year.

Reichenbacher [4] discusses how visual complexity in a map is influenced through structural and syntactic properties symbols, such as the density, number and opacity of map elements, their visual complexity or number of colour values or hues. He shows how context can be communicated through manipulation of these properties. Cognitive complexity emerges during the processing of the map, i.e. the understanding of the map within a specific context, as users attempt to understand the underlying relationships between displayed elements [6]. Finally, Crease [7] separates the complexity that emerges during the representation of many elements of differing categories (high semantic) and many elements of the same category (high visual).

Based on this background, we decided to investigate the potential of conveying environmental (social) context semantics on a map, without cognitively burdening the user. In POI-driven applications, a 2-D graphical background (map) is used to visualize spatial context spatial context (i.e. the location of POIs), which shows the contextual relationship between items of information (i.e. the POIs). Based on this successful principle, we considered adding a further background layer upon which spatialised

context can be overlaid. Hence we used a heatmap technique to display the “busy” areas of a city. This heatmap is temporally sensitive (i.e. it is calculated using temporally relevant data such as the weekday and current hour) and displays the intensity of user interactions with venues through social media under that temporal context. The use of a heatmap to display density of POIs has been explored in the past in such studies as Kisilevich [8] and Girardin [9] but we are not aware of any studies that have used such a technique in conjunction with POI layers.

2. Using social context in maps

2.1. Collecting and disseminating social context over the cloud

In [10] we describe our system for collecting social context in more detail and also demonstrate that the collected data is a reliable indicator of human activity in a urban area, as it correlates well with other independent data such as air pollution from traffic. Hence we will describe the system briefly. The system is based on a set of virtual “listening posts”, i.e. a set of coordinates in a urban area, which can be arbitrarily placed or positioned based on local knowledge of a city. For each coordinate we perform a request for data on various APIs (Facebook, Google Places, Foursquare) every half hour. The returned data is stored in a database and thus allows us to perform temporally and spatially contextual queries in order to build aggregate pictures of activity in an area. From this data, we can offer cloud-based services to power a number of ubiquitous applications, such as desktop or large display websites, mobile websites, mobile apps and augmented reality apps (Figure 1).

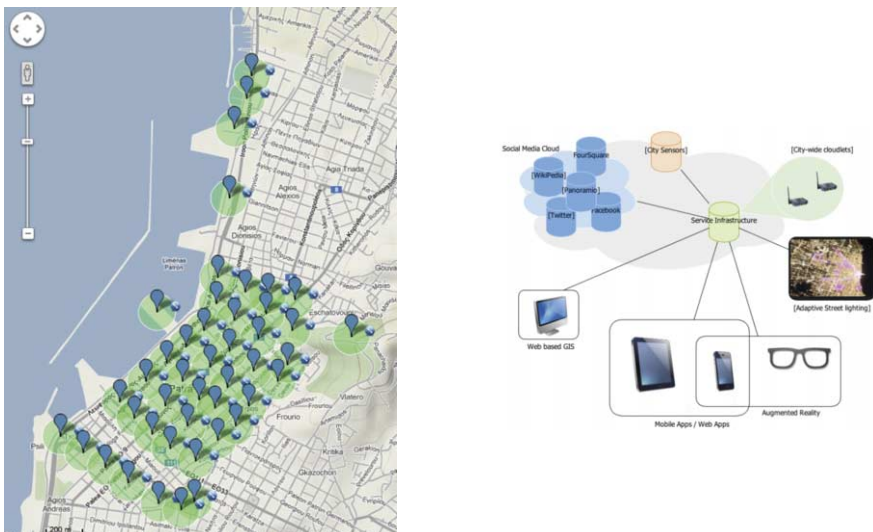

Figure 1. Area coverage for social data by listening posts and abstract system architecture for sharing social context as a cloud service

2.2. Using social context for ubiquitous maps

We focused on a scenario of travel that includes the use of ubiquitous maps and involves planning tasks. This scenario includes a difficult planning task – firstly, the user is in a completely new location for which she is unprepared. Because this is a transit destination, the user has not made previous plans and has to rely on whatever information can be gathered quickly. The user not only has to think about the landmarks which they will visit and how far apart they might be, but also has to consider the task of getting lunch somewhere before heading off. The scenario is as follows:

“You are transiting through a city which you are unfamiliar with. Having just missed your train connection, you are waiting in this city for a few hours in order to catch the next train towards your final destination. It’s 11am on a Saturday morning, and your train leaves at 4pm, so you have enough time to visit a couple of landmarks and then get lunch, before heading off.”

Of course, in a real system the scenarios could be more complicated or a system could attune its performance to respond to different situations (e.g. filtering out data from one-off events such as concerts etc). However our target here was to investigate how a background visualization of context might help planning tasks, so we focus on the impact of visualizations in decision making, not on how these are derived.

2.3. Experiment design

We planned to show users four different maps (Figure 2) and ask them to circle up to two areas on these maps which they think they would like to visit. For each map type, we would take the time taken to complete the task, as well as a short subjective opinion questionnaire to determine complexity, ease of use, learnability, confidence and perceived utility. We further wanted to see if users’ perceptions might be affected by their use of social networks thus a separate questionnaire was given pre-task.

On the first map, only information about landmarks is presented. The landmarks are drawn from geo-tagged Wikipedia entries. The second map shows landmarks and a further layer of POIs, which are restaurants. The POIs are presented in two ways – simple green markers and “fire” markers, which indicate really popular restaurants. The popularity of restaurants is calculated through the total number of check-ins at these venues. The third map shows landmarks and a heatmap background layer. This heatmap is calculated from restaurant check-in data between the hours of 1-4 pm, hence it shows which areas of the city are bound to be “busy” or otherwise “active” at these times. The fourth and final map is a combination of all the above elements.

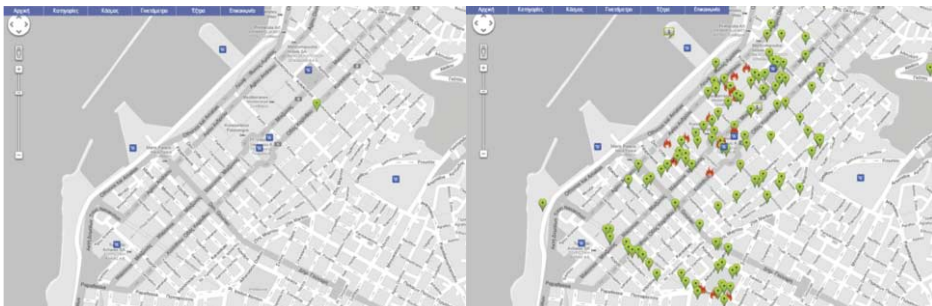

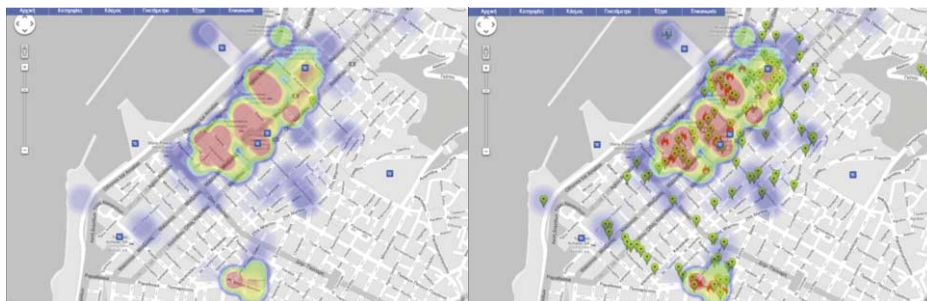

Figure 2. Map types shown to participants (clockwise from top-left: Landmarks, Landmarks + POIs, Landmarks + Heatmap, All)

2.4. Participants

We recruited fifteen participants (6 female) in a university café. One was over 34, four were between 30-34, four between 19-23 and six between 24-29 years old. We asked participants about social media use (which network and how often) and also the type of actions taken through these networks (tagging friends or locations and checking-in). We found that all users were familiar with the concept of checking into a location using social media, though this action is the least popular (six participants stated they never do it). This was important, as we wanted to ensure that participants understood how the map visualizations were derived.

We examined the frequency of use of the various social networks as well as the interactions with these, which related to spatial context (Figure 3). Using a simple metric of multiplying the frequency of use score with the sum of location tagging and checking-in frequency scores, we split our users into two categories based on “location consciousness” exhibited through the use of social networks (min=8, max=130, mean=61, stdev=43.4). Figure 4 below shows how these participants use information sources, both traditional and electronic, when planning activities before or during a visit to a new location. We observe that location conscious (LC) participants favour guidebooks (1st) and community websites (2nd) most, while other participants seem to value friends and relatives (1st), followed by community websites (2nd). For them, guidebooks rank 4th, while their third preference is locals and residents. These findings confirm that community websites, i.e. information that is compiled by independent individual internet users is seen as a trusted resource of information.

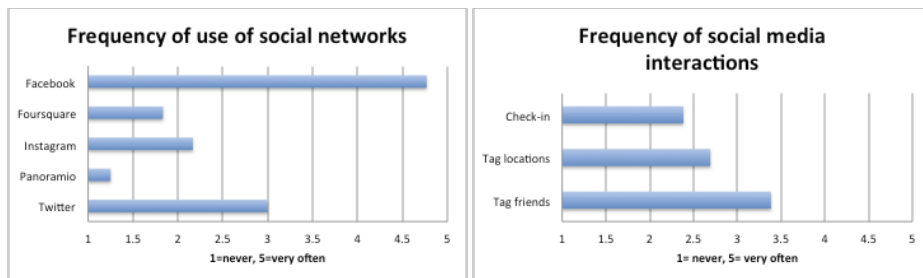

Figure 3. Use of social media by participants

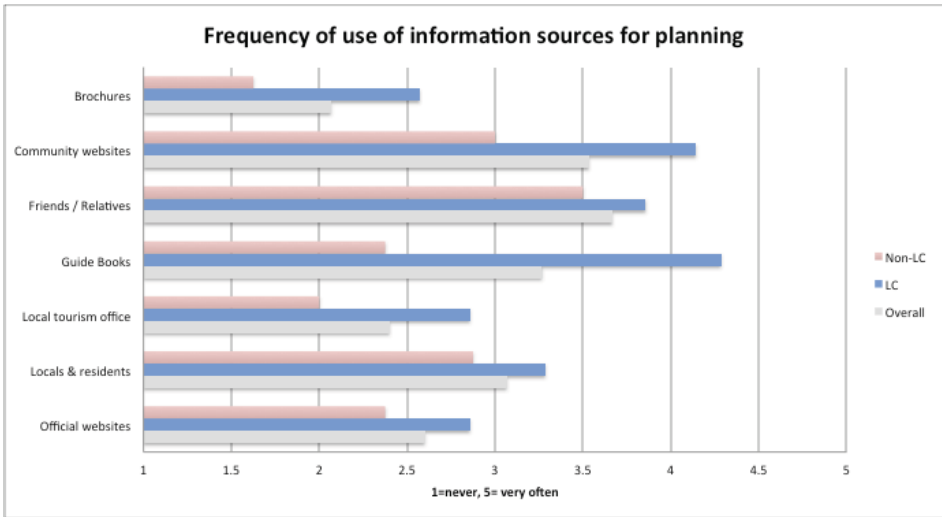

Figure 4. Participants' use of information sources for tourism

2.5. Attitude towards map use

We showed the participant each map type (as shown in Fig. 2) one at a time. The map types contained landmarks only (L), landmarks and POIs (L+P), landmarks and heatmap (L+H) and a combination of all data (A). Before showing a map, we reminded the participants of the scenario to affirm that their planning needs have not changed and then provided them with a pen to mark down the areas they would like to visit. We measured the time taken to complete the task and issued a short questionnaire after each task was completed. The results of the questionnaire responses are shown in Figure 5.

In terms of time taken to complete the requested tasks, we found that users were quickest with the map type A ($m=7.25s$, $stdev=3.22s$) followed by types L+P ($m=8.32s$, $stdev=4.03s$), L+H ($m=9.12s$, $stdev=3.04s$) and L ($m=13.43s$, $stdev=2.77s$).

To determine the validity of average differences in the time and questionnaire responses for each map, we performed an ANOVA analysis (Table 1), which indicated that there are no statistically significant variations in the times taken to complete the tasks. However we found statistically significant variations in the means measured in the questions of whether it was easy to make a decision using each map type ($p<0.05$), the level of confidence on making choices ($p<0.05$) and finally intention to use each map type during a visit ($p<0.01$). We note that in all cases apart from complexity, the landmark-only map is the worst-performing of all. In all cases the different display modes (POIS, heatmap or combination) are quite close in terms of their mean scores. This result is encouraging as it suggests that the use of heatmaps as an additional visual mode to represent context does not overburden the user.

We did not make any analyses on the individual groups as the sample size was too low for meaningful interpretation. However, some interesting observations emerge. Firstly, location-conscious social network users found it easier to decide with the A-type map, which contained a combination of all data, than in any other case. In contrast, other participants were not majorly affected by the map types, though their confidence

in their choices also increased when shown the map that contained the most information. Both groups indicated the same intent levels for using the A-type map in future visits, though intent levels for map type L+P were somewhat stronger for the location-conscious users.

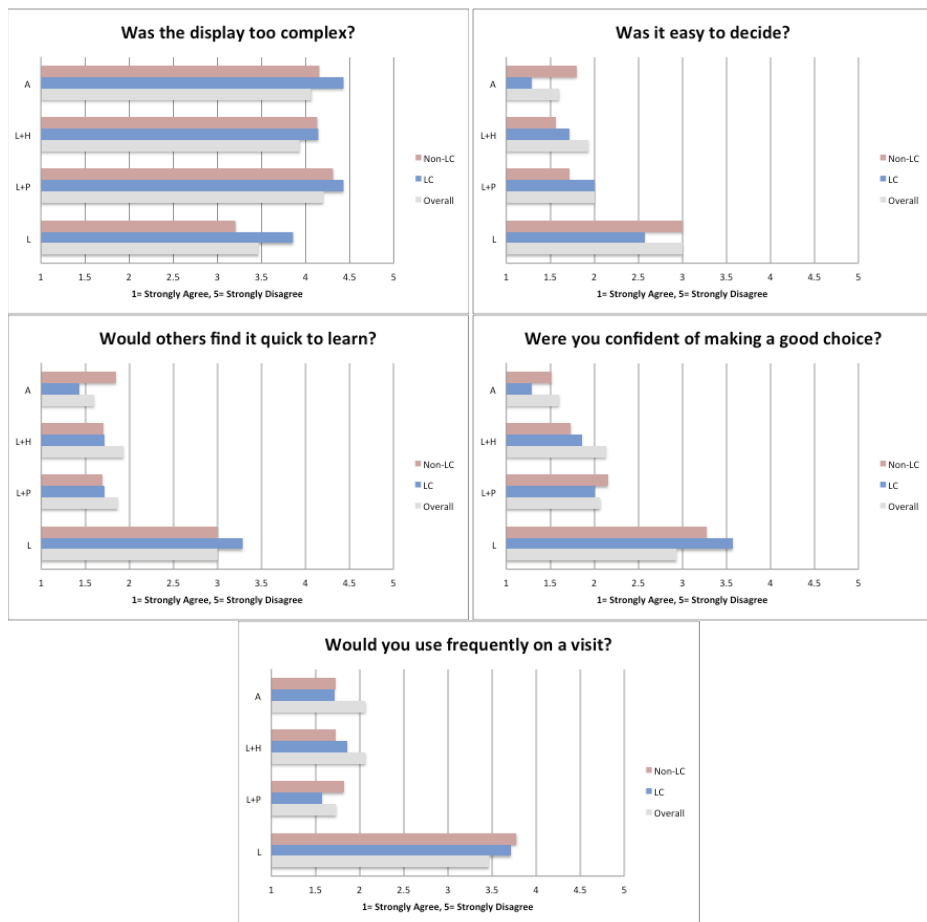

Figure 5. Participants' attitudes towards the map styles

2.6. Area selection behaviour

As stated previously, part of the experiment was getting users to demonstrate the areas of their choice. Users were able to select up to two areas, which could be as big or as small as they desired, based on how much they thought they had time to explore. Users marked these areas on transparencies, which were laid over each map type, without being able to see what previous participants had chosen. We scanned and assembled these choices to form a collective impression for each map type. Figure 6 below shows how participants indicated their preferred areas.

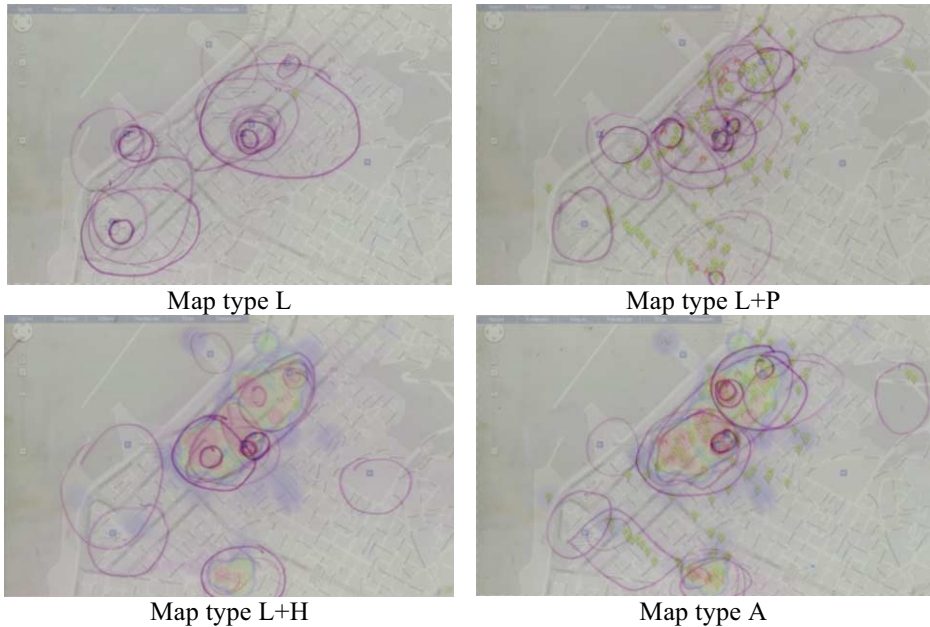

Figure 6. Participants' choices of areas to visit

From these pictures it is easy to see that for the first style of map (landmarks only), behaviour is centred on the landmarks and uncertainty is apparent as the participants seem to make larger area selections than in other style maps. When presented with POI information (map two), participants seemed to narrow down the areas of visit and also appeared lured by the presence of POIs that were not near any the landmarks. Similar behaviour is exhibited in map style three, though this time users made fewer choices of areas to visit (i.e. more users selected just one area). Finally, map four again shows very similar behaviour though in this case, all exploratory selections (i.e. those that are far from the landmarks) are made either on areas where POIs are clustered or where activity is indicated (contrast with map two where the mere presence of POIs does not seem to tempt the explorers).

2.7. Informal feedback

We engaged the users in a short, unstructured interview after the tasks had been completed in order to elaborate on some of their behaviour. We noted from their choices that some participants (six in total) were keen to avoid busy areas as indicated by the presence of POIs or heatmaps and identified themselves as independent and exploratory travelers. They mentioned that heatmaps were particularly useful in order to be able to determine where “off-the-beaten-track” locations were likely to be found and enjoyed this feature. Another female participant stated that she quite liked the heatmap visualization, as she felt safer knowing that she would be in a busy area, particularly in a city that she didn't know as well. Overall thirteen out of the fifteen participants stated they preferred the combinatory system out of all the map types,

because it provided the most amount of information without making the display overly complex or cluttered.

Table 1. Detailed results of attitude towards map types (L=Landmarks, P=POIs, H=Heatmap, A=All)

Question		Mean	St.Dev.	F	p
Was the display too complex? 1=Strongly Agree 5=Strongly Disagree	L	3.4667	1.1457	0.778	0.511
	L+P	4.2000	1.1464		
	L+H	3.9333	1.3345		
	A	4.0667	1.6242		
Was it easy to decide based on this information? 1=Strongly Agree 5=Strongly Disagree	L	3.0000	1.4639	3.308	0.027
	L+P	2.0000	1.1953		
	L+H	1.9333	1.3870		
	A	1.6000	1.0556		
Would other people find this system quick to learn? 1=Strongly Agree 5=Strongly Disagree	L	3.0000	1.1559	2.366	0.081
	L+P	1.8667	1.0601		
	L+H	1.9333	1.3354		
	A	1.9333	1.1338		
Did you feel confident that you made a good choice with help from this system? 1=Strongly Agree 5=Strongly Disagree	L	2.9333	1.5338	3.020	0.037
	L+P	2.0667	1.0998		
	L+H	2.1333	1.3020		
	A	1.6000	0.9103		
Would you use this system frequently during visits to unfamiliar cities? 1=Strongly Agree 5=Strongly Disagree	L	3.4667	1.3558	4.879	0.004
	L+P	1.7333	1.0998		
	L+H	2.0667	1.3345		
	A	2.0667	1.5796		
Time	L	13.425	3.2003	1.153	0.361
	L+P	8.3250	4.0333		
	L+H	9.1250	8.0454		
	A	7.2500	3.2265		

3. Conclusions and Future work

Our study into visualizing urban social context and sharing it with visitors of a city is in its preliminary stages. As the work presented here is a first step towards investigating the use of background layers to convey environmental context, there are limitations to our methods and findings which leave considerable scope for additional work to be carried out.

Asking our participants to “circle” areas of interest is, in a way, an artificial task. One could envisage how a user might actually do this if a map was presented on a tablet-size device, but such a task would be hard to do using a mobile phone (small scree, large fingers). Also, as noted from our experiments, different users use different size of “circles” to indicate areas of interest. Some like to use wide circles, others prefer a smaller area (indicating more or less a spot around which they would like to wander). Offering guidance to users so they can visit an area has to depend on a definition of an area, negotiated between the user and a device. We believe here that given the users’ behaviour, it might be best to allow users to “tap” on a point and have the area defined (drawn) around it by the system, either in terms of a circle, or by automatically discovering road edges and creating enclosing polygons to define the area. Also, we believe that it would be good to allow users to define the radius of this

area, but using “time to walk” as a parameter instead of actual distance (meters), since this is measure is more meaningful to most users.

Further to this, we are not confident that a heatmap is the optimal way to present background context information. Based on our participants’ comments, a more abstract representation might be preferable. One possible alternative approach is to divide a city into “areas” corresponding to sections defined by road segments, and then colorize the segments according to social context data. We have began looking into this approach using OpenStreetMap data (Figure 7), however there are technical complexities in defining the “areas”, particularly in cities where the road structure is not a neat grid and also where the map data is not “clean” and contains erroneous or mal-described nodes.

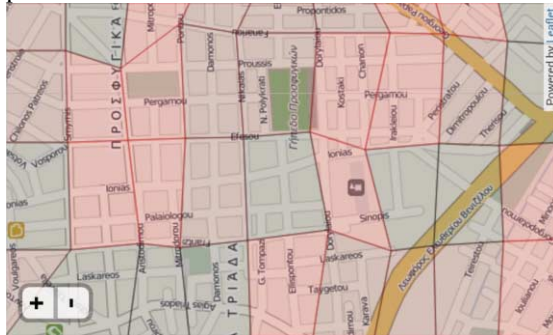

Figure 7. Grid-based visualization of context as an alternative to heatmaps

Our first findings however, suggest that visualizing social context as a background layer in maps, does not hinder users cognitively and can lead to a useful service. We uncovered some early indications that our visualization has an effect on user choice of areas, which is made with more confidence than just by presenting POIs alone. In the near future we will expand our work to investigate the emergent issues more systematically, with more users and further map complexity levels on varying devices.

References

- [1] U. Gretzel, U. and K. H. Yoo, Use and impact of online travel reviews. *Information and communication technologies in tourism* (2008), 35-46.
- [2] R. White, and G. Buscher, Characterizing local interests and local knowledge *In Proceedings of the 2012 ACM annual conference on Human Factors in Computing Systems* pp. 1607-1610. ACM 2012
- [3] M. Kenteris, D. Gavalas, and D. Economou. Electronic mobile guides: a survey. *Personal and ubiquitous computing* 15, no. 1 (2011): 97-111.
- [4] T. Reichenbacher, The concept of relevance in mobile maps. *In Location based services and telecartography*, pp. 231-246. Springer Berlin Heidelberg, 2007.
- [5] Nivala, Annu-Maaria, and L. Tiina Sarjakoski. "Adapting map symbols for mobile users." *In Proc. of the International Cartographic Conference*, pp. 9-16. 2005.
- [6] Fairbairn, D. (2006). "Measuring Map Complexity." *The Cartographic Journal* 43(3): 224-238.
- [7] Crease, Paul, and Tumasch Reichenbacher. "Adapting cartographic representations to improve the information seeking of LBS users." *In Proceedings of 25th international cartographic conference*. 2011.
- [8] Kisilevich, Slava, Florian Mansmann, Peter Bak, Daniel Keim, and Alexander Tchaikin. "Where would you go on your next vacation? A framework for visual exploration of attractive places." *In Advanced Geographic Information Systems, Applications, and Services (GEOPROCESSING), 2010 Second International Conference on*, pp. 21-26. IEEE, 2010.
- [9] Girardin, Fabien, Filippo Dal Fiore, Josep Blat, and Carlo Ratti. "Understanding of tourist dynamics from explicitly disclosed location information." *In Symposium on LBS and Telecartography*. 2007.
- [10] A. Komninos, V. Stefanis, A. Plessas, J. Besharat (2013) : "Cloud based capture and sharing of urban dynamics using scarce check-in data", *IEEE Pervasive Computing* vol. 12., Issue 4 (accepted, in print)

Towards the Sociable Smart City

Eleni CHRISTOPOULOU^{a,1} and Dimitrios RINGAS^b

^a*Department of Computer Engineering & Informatics, University of Patras, Greece*

^b*Department of Informatics, Ionian University, Greece*

Abstract. In this paper we present our vision on the Sociable Smart City. In our view cities are the people that inhabit them, their memories, stories, concerns and the culture that develops through their social interactions. The application of urban computing has a significant social and cultural impact on the city and on city life. Attempting to realise our vision, we designed and deployed CLIO, an urban computing system aiming to allow people to interact with the collective city memory. Our findings revealed that a system that exploits city infrastructure and both people's and artificial intelligence in order to empower and engage them in social activities may enhance citizen participation and sense of belonging as well as it may enable urban social interactions.

Keywords. Sociable smart city, urban informatics, mobile computing, smart city

1. What is a City?

A city can be regarded as a permanent installation, large enough and structured in order to facilitate the collective and social life.

A radical change in human evolution came when human selected to live in permanent settlements and early forms of cities started to appear. From a demographic perspective a city is defined by four characteristics: permanence, large population size, high population density and social heterogeneity [9]. A distinct characteristic of each city is its relation with the physical landscape; the surrounding environment and the way a city is structured and evolved, affect the unique character of a city. All cities offer certain functionalities; they may serve as political, religious and economical centres.

The diffusion of ubiquitous computing into modern cities and the massive use of mobile devices have shifted researchers vision to explore ideas about the cities of tomorrow; terms as “smarter cities”, “iphone city”, “sentient city”, “digital cities”, “intelligent cities” have emerged.

A city can be defined as smart when investments in human and social capital and transport and ICT communication infrastructure fuel sustainable economic development and a high quality of life, with a wise management of natural resources, through participatory action and engagement [2].

The characteristics of a smart city can span across all activities that occur in city life [4]:

¹ Corresponding Author: Eleni Christopoulou, Department of Computer Engineering and Informatics, University of Patras. Email: hristope@ceid.upatras.gr

- **smart economy** focusing on competitiveness, entrepreneurship and ability to transform
- **smart mobility** focusing on innovative and safe transport systems and availability of ICT infrastructure
- **smart environment** focusing on sustainable resource management and environmental protection
- **smart people** focusing on social and ethnic plurality, human capital and participation in public life
- **smart living** focusing on quality of life, social cohesion and cultural and educational facilities
- **smart governance** focusing on participation in decision-making and public and social services

A city can be regarded as intelligent when it combines the following three dimensions [6]; the *inividuals' intelligence* and creativity, the *collective intelligence* of the city population as well as the *artificial intelligence* embedded into the city.

There is a wealth of paradigms applying ubiquitous, pervasive and mobile computing to urban spaces focusing on providing new services to citizens and enhancing their daily routine; many attempts envision and gain inspiration from the cities of the future. However, as urban computing lies on the intersection of architecture, social interaction and design of computer systems for use in urban areas [5], it does not plan the city of the future but it allows people to interact with their cities in novel ways aiming to shape and decide the future of their city.

2. Reaching the Sociable Smart City

Sociable: willing to talk and engage in activities with other people; friendly (Oxford dictionary)

Sociable is a place that is friendly and attracts people to spend time on it. It is a place that encourages communication among people and fosters a convivial mood. It is a place where people can be extrovert and engage in outgoing activities. It is open and welcome, approachable for all.

The sociable space concept [1] relates the physical structure, the functions and the activities in an urban environment. The structure and infrastructure of a city determine connectivity and accessibility; the design of structure makes it possible for functions to be established. The space functions in various forms; it provides communal, public and commercial services, it offers greenery and recreational facilities, it presents historical and aesthetical elements. Functions act as catalysts, attract people, encourage activity and movement and enhance quality of life and culture.

Activities that occur in a space reflect its sociable character. A public open space invites people to spend their leisure time: discuss the news, share a meal, linger and meet, play a game. Unexpected activities happen breaking the routine and providing variety; on a scheduled route one can meet unexpectedly a friend and chat for a minute or witness a street art performance. Occasional events, like personal or public celebrations, festivals and cultural events, markets and fairs, intervene the daily activities and the space is transformed to adapt. A responsive and creating environment can provide a fertile ground for learning and challenge experiences. A calm and harmonious space allows for spending some comfort and resting time.

Activities occurring in an urban setting are the catalysts for social interactions. Interactions among people and between people and the physical space in a modern city shape the unique character of each city. Cities are not just infrastructure and services; while all modern cities share the same infrastructure and offer similar functions, each and every one has evolved a unique character reflected in everyday life and culture. Cities are the people that inhabit them, their memories, stories, concerns and the culture that develops through social interaction.

A sociable smart city by definition should offer a wealth of novel infrastructure and services, however the focus should not be on technology, but on people. ICT infrastructure and digital technologies may empower people to participate and engage them to act on collectively shared issues. Such a city assists people to develop a shared sense of belonging and a feeling of ownership and responsibility to improve their city. Digital tools and new media can connect people and their experiences with the city. City infrastructure may enable game activities, learning processes and cultural events. A primary definition for the sociable smart city follows.

A sociable smart city is one rich in infrastructure, which combines and exploits both people and artificial intelligence, empowering and engaging people in activities where urban social interactions thrive aiming to advance the quality of life and culture.

3. CLIO: A Case Study on Sociable Smart City

In this section we present CLIO, acronym for ColLECTive cItY memOry, an urban computing system aiming to invite people to share personal memories and allow them to interact with the collective city memory [8], [3]. Our aim was to study how urban computing alters the city, the perception of people about the city, the communication and interaction among people and the social and cultural impact on the city and on city life.

The collective city memory is a form of collective memory that is created through the interaction among individual memories attached to the city landscape; however it is the interaction among people and memories that is the most important factor in this process. In social groups this interaction is taking place with conversations and exchange of narratives, which lead to identifying common views and to creating groups of relevant memories. To achieve this on computer systems, memories have to be related to each other based on content, context or narrator. Collective memory is then transformed to collective city memory when it is attached to the urban landscape and acquires points of reference.

Memories shared on CLIO consist of content like photos, audio or video clips and text, and context information like place and time it refers to, relevant events, ratings, tags and comments. Memories context categorises them in themes and the user context is exploited to match users to memories and provide intelligent recommendations. CLIO is an urban computing system open to everyone who wishes to share personal memories and to place them on a map in order to contribute to the collective memory of a city. In order to successfully blend the collective city memory with the city landscape, CLIO has been offered via several interfaces.

A familiar web-based interface was initially used; this was suitable for the general public enabling people to browse memories based on web-based map applications and tag cloud views. In order to enable people to interact with the collective city memory in its physical space, while following the pace of a user traversing the city, we released an

Android-based mobile application. In Oulu we exploited the city's public ubiquitous infrastructure that included an array of public interactive displays [7], in order to blend the collective city memory into the city landscape and attract people to interact with it. An off-the-self augmented reality browser was exploited aiming to offer the users of CLIO an immersive experience.

3.1. Impact on social and cultural life of a city

Regarding CLIO as a system of a sociable smart city empowering and engaging people in activities involving social interactions, we assessed its social and cultural impact on the city life. Field experience from the in-the-wild deployment of CLIO in two different cities, Corfu and Oulu, proves its benefits to a city community regarding participation, engagement, sense of belonging, social interactions and intergenerational dialogue, as well its contribution to cultural heritage preservation [3], [8].

We approached participation studying first whether people share their personal memories. Field experience shows that people who interact with CLIO start conversations and exchange similar personal memories; those who are fluent with mobile technology may share their comments and memories on the system. This exhibits the need for novel means of collecting memories, simulating the traditional human-to-human communication in society. Additionally, the pattern of interaction positively indicated community appeal and engagement.

Interviews and observations revealed that CLIO might enhance the sense of belonging in a community. People are initially hesitant to interact with CLIO, however, once they get familiar with it they rate, comment and share similar memories thus expressing their need to share their attachment to a memory, a location or an event.

Both the variety of user interfaces and the city infrastructure affected the social interactions we witnessed. Most people experienced strong emotions like laughing or arguing, as they often felt connected with the memories they viewed. The existence of public displays as anchors in the physical space attracted people and facilitated social interactions. Another positive outcome was the promotion of intergenerational dialogue, as groups of different ages often compared their memories and experiences. Finally, interviews recorded many positive comments about the idea of capturing personal memories and preserving this part of city culture.

4. Realising the Vision of the Sociable Smart City

Experience with CLIO has shown that a system that exploits city infrastructure and both people's and artificial intelligence in order to empower and engage them in social activities may advance the quality of life and culture.

The city infrastructure has a vital role in empowering and engaging people in activities involving urban social interactions. Our case study shows that the lack of reliable communication infrastructure in Corfu often broke the user experience and discouraged further adoption. On the other hand, the plethora of communication and interaction means in Oulu attracted people and enhanced their experience with CLIO. These demonstrate that modern cities should invest in deploying infrastructure; open communication systems should be offered ensuring people's right to access and cloud based solutions should be adopted providing a number of services and applications.

In a sociable smart city both people and artificial intelligence is combined and exploited to leverage new forms of social interactions. In CLIO we have come across the need of adopting semantic web technologies for representing and reasoning on large amount of data. Particularly, contextual information poses the need for distributed and dynamic aggregation and interpretation of heterogeneous data. A well-suit solution when developing context-aware urban computing systems seems to be the adoption of semantic web and linked-data technologies for processing vast amount of information.

Urban social interactions reflect the sociable qualities of a city; rich social interactions strengthen the community. A sociable smart city seeks to promote such interactions aiming to advance the quality of social and cultural life. CLIO, a context-aware urban computing system that encompasses intelligent data management and smart exploitation of a city infrastructure, attracts and persuades people to participate in a social process of the public life, involves them in an engaging procedure of preserving a part of the city culture and strengthens their bonds with the community. The wide adoption of social networks exhibits the wish of people to share and communicate; the CLIO case study reveals that this is also feasible in the context of a city. Therefore, the introduction of innovative applications in social life has the potential to promote citizen participation, develop a shared sense of belonging, assist decision-making and organise people into collective goals.

References

- [1] M. Bäckman, M. Rundqvist, *Sociable Space in a City of Life - the Case of Hanoi*, Master Thesis, Blekinge Tekniska Högskola/Sektionen för Teknokultur, Humaniora och Samhällsbyggnad (TKS), 2005.
- [2] A. Caragliu, C. Del Bo, P. Nijkamp, *Smart cities in Europe*, *Serie Research Memoranda 0048* (VU University Amsterdam, Faculty of Economics, Business Administration and Econometrics), 2009.
- [3] E. Christopoulou, D. Ringas, M. Stefanidakis, *Experiences from the Urban Computing Impact on Urban Culture*, *16th Panhellenic Conference on Informatics*, (2012), 56-61.
- [4] Chr. Fertner, H. Kramar, R. Kalasek, N. Pichler-Milanović, E. Meijers, *Final Report on Smart cities – Ranking of European medium-sized cities*, Centre of Regional Science, Vienna UT, 2007.
- [5] F. A. Hansen, K. Gronbaek, *Social web applications in the city: a lightweight infrastructure for urban computing*, *Hypertext 2008*, (2008), pp.175-180.
- [6] N. Komninos, *Intelligent Cities and Globalization of Innovation Networks*, Routledge, London and New York, 2008.
- [7] T. Ojala, H. Kukka, T. Lindén, T. Heikkinen, M. Jurmu, S. Hosio, F. Kruger, *UBI-hotspot 1.0: Large-scale long-term deployment of interactive public displays in a city center*, *5th International Conference on Internet and Web Applications and Services*, (2010), 285-294.
- [8] D. Ringas, E. Christopoulou, M. Stefanidakis, *CLIO: blending the collective memory with the urban landscape*, *Mobile and Ubiquitous Multimedia* (2011), 185-194.
- [9] L. Wirth, *Urbanism as a Way of Life*, *American Journal of Sociology* **44** (1938), 1-24.

Integrating modern mobile devices in emergency event reporting and notification

Lambros Lambrinos and Karim Bechara

Department of Communication and Internet Studies

Cyprus University of Technology

Limassol, Cyprus

{lambros.lambrinos, kb.bechara@cut.ac.cy}

Abstract. Integrating the processes of information gathering, processing and dissemination in emergency and disruption situations still has a number of open issues that often create further dangers or inconvenience. In this paper we describe the architecture and implementation of a system specifically designed to encapsulate the aforementioned processes; its modular and layered structure allows for better integration of new components, information sources and sinks. We show particular interest in utilising today's mobile devices as they are often used by people to report emergency situations to the authorities and can provide enhanced information e.g. exact geographical location; the person reporting is either directly involved in the incident or has witnessed its occurrence. Event information is disseminated to users in the vicinity but they may also opt to receive all events and perform location-based filtering on their device to refrain from providing their own location information.

Keywords. Emergency event reporting and information dissemination, Mobile device geolocation, Location based services

Introduction

Reporting an incident or disruption to the public services responsible is a task often performed by members of the public. In comparison with 15-20 years ago, today's evident proliferation of mobile devices allows for earlier reporting of incidents. The use of a mobile device allows for such reporting from anywhere there is cellular coverage.

In addition, taking advantage of the capabilities of today's mobile devices (of which the percentage of smartphones is steadily increasing) and more specifically location identification, various services, widely known as Location Based Services (LBS), have been developed and deployed. This actual ability, to obtain further information from the device and transmit it to the authorities, can be crucial in some instances (e.g. if callers are not aware of their exact location). From a user perspective, aside from the reporting capabilities, being able to receive event notifications is quite important as one may choose to avoid areas affected by any form of disruptions.

In the context of this paper, we broadly classify emergency events as those events that cause a deviation from normal circumstances and in many occasions result in life threatening situations. On the other hand, disruptions are those occurrences which affect standard daily routines without imposing any risks. We will use the term 'event'

throughout to cover all these types. It is important to note that events can have side effects that may go on for some time after the event has taken place e.g. a motorway accident that results in lane closures which create heavy traffic.

Let's consider the scenario shown in Figure 1: a driver observes a fire and uses a smartphone to report the breakout as well as its location. As a result of the call, the authorities arrive to the area; at this point the incident is confirmed and its extent assessed. Hereafter, any drivers approaching the area of the fire receive a warning and can thus change their route if they can; this reduces potential danger and inconvenience.

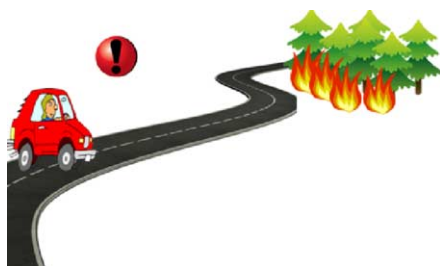

Figure 1. Event witnessing and reporting.

The system we propose aims to fulfill the functionality just described. To a certain extent, our work falls under the general area of crowdsourcing or participatory sensing which has recently been attracting research and commercial interest. Among the key design elements proposed is a modular and extensible data management architecture that involves an intelligent information processing stage and a mobile phone application that provides users with the ability to report various event types and receive notifications for events near them which are subsequently displayed on a map.

Moreover, addressing privacy concerns, we allow users to select the type of information they receive i.e. 'subscribe' at different levels. To make our information dissemination process more 'personalised' and location, as well as event, specific (and at the same time save on central system resources) we require users to frequently report their location. Since for many reasons (e.g. privacy, device capabilities or resource conservation) this may not be possible, event filtering can take place at the user devices.

This paper is structured as follows: section 1 provides some background information along with related work and section 2 presents the proposed system's architecture and implementation; the final section contains our future work plans.

1. Background

Emergency notification systems are not a new concept and various solutions have been deployed over the years. One of the most common and traditional mass notification methods relies upon radio and television announcements. The authorities usually resort to such methods when an event is expected to affect many citizens; it is often the case that announcements are not made quickly and do not have the desired outcome.

Utilising today's telecommunication infrastructures, other methods have also been deployed in an attempt to provide more targeted information. These are largely based upon the concept of Location Based Services [2, 7] which was introduced a number of years ago with a number of potential uses. Cell broadcast is one such method and it

involves the transmission of a message to all mobile phones that are within range of a given cell; although effective, it requires prior arrangements with network operators.

Other solutions proposed are more targeted to specific situations. In [4] the authors highlight the need for such systems from a medical perspective concentrating on controlling the spreading of diseases. Other researchers [6] concentrated on handling situations where regional communication infrastructures have failed and proposed the use of geographic regions as rendezvous points for information seekers and providers; nodes obtain their localization information and use wireless communication to exchange information in their region. Such applications can be complementary to our work; they essentially concentrate on building a challenging underlying communication infrastructure which is highly applicable and desirable in certain situations.

Targeting specific areas and user groups has also been an objective and Georgia Tech [1] has installed a system that uses e-mail to notify all students and staff when an event occurs within the university campus; users can also opt in to receive text notifications on their mobile phones. Malizia et al. [3] have suggested an ontology-based alert dissemination system for assisting more vulnerable citizens. Web-based platform Ushahidi [10] was specifically designed for event reporting via text messaging or on-line and also enables the study of historical event data.

A certain characteristic of the systems just mentioned as well as the various other commercial offerings is that they often follow a one-size-fits-all approach without necessarily allowing any form of user preferences or personalization. Moreover, they assume that event data already exists in a way ignoring crowdsourcing which is a highly popular [11] information gathering tool in a multitude of applications. We view the ability to collect data from the public as highly crucial in emergency situations and the more accurate and informative is such data, the better the assessment and response on behalf of the authorities. In [8] it was shown how effective crowdsourcing can be after a disaster and in [9] we suggested how processing caller location information can provide useful indications on the geographical scale of an event.

In our work, we focus on integrating modern mobile devices in emergency event reporting as well as information dissemination to users based on their own preferences. Even though a centralized architecture may not be appropriate in certain situations (e.g. failure of core infrastructures) it can be useful in creating the 'bigger picture' of an event or disruption. In turn, this can assist in estimating the effect of an event outside its immediate geographical area and allow the authorities to deploy mechanisms to reduce its immediate and potential impact. Reverse 911 [5] is an indicative example of what we are trying to achieve from an information dissemination perspective; the system calls a list of predefined phone numbers when an emergency occurs in the area.

2. Incident Information System

Handling emergency event data is certainly a complex task. Considering the fact that there is a multitude of information sources as well as many parties interested in such information, certain processing actions as well as informed decisions are necessary.

2.1. Information flow

Information on an event is expected to pass through a number of stages before it is actually disseminated to any entities. Keeping those stages distinct allows for greater

flexibility and future enhancements; in figure 2 we see the information flow and some of the entities involved in creating and receiving the information during the process.

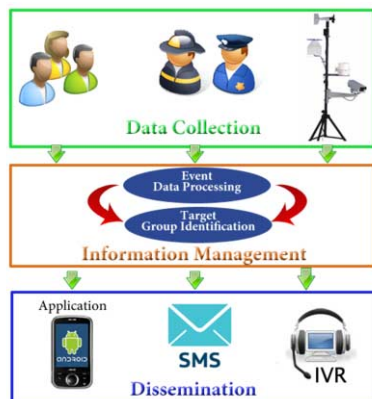

Figure 2. Layered Information Flow

At the first stage ('Data Collection'), event information is expected to be gathered from a variety of sources: a) the general public, who report incidents primarily through their phones (e.g. via a normal call, a text message, a special application), b) the competent public services, who report incidents that they detected or verify those that citizens reported to them, and c) any automated detection mechanisms and sensors, such as a weather station, that can detect adverse weather conditions in an area, a vehicle collision detection system and a forest fire detection system.

All data gathered is processed at the incident "Information Management" stage. Initially, information collected from the various aforementioned sources, is analysed; as a result, a new event may be added or an existing event removed or altered (e.g. change of location, description etc.). At this stage, various algorithms may be introduced to evaluate current incidents or to calculate a variety of attributes such as the extent of a fire based on the reports received from various geographic locations [12].

Note that the accuracy of the information gathered with respect to an event is expected to vary and is highly dependent on the event type and the source of the information. Some events (e.g. fire) are visible from larger distances compared to others (e.g. accident) hence the location of the reporting user (as obtained by the mobile device) may differ; enhancing the event location accuracy may be achieved through verbal communication or other technical means but this is outside the scope of this paper. Moreover, the reporting of an event by multiple users has a number of implications: it first increases the credibility of such reports but quite importantly it helps the authorities assess the severity of the event and decide on further actions to be taken. Among such actions is the decision making process that defines who should receive information concerning the event. This again depends upon a number of factors which include the type of the event, its expected duration and its potential impact to the general public. Thus, this stage concludes with the entities that must be notified.

Finally, at the 'Dissemination' stage, event information is distributed to the selected parties (e.g. members of the general public, other authorities etc.) in a multi-modal fashion. We emphasize here on methods that are expected to notify users immediately i.e. an application on their mobile device, a text message (SMS), and IVR

(Interactive Voice Response) systems which automatically call a telephone number and when the call is answered play out a pre-recorded message with event information.

2.2. Implementation

For the purposes of our implementation, we concentrated on a subset of the system which we believe poses particular challenges but at the same time can introduce significant enhancements in existing services; particularly, we implemented the so called ‘crowdsourcing’ part for event reporting, the processing of the information obtained by the end users and the information dissemination to them via an application running on their phones. The client side of the system was implemented on the Android platform and the server side was based upon a Java program and a MySQL database.

Users running the client application can opt to register on the system which allows them to define some preferences (e.g. for which types of events to be notified); for obvious reasons, reporting of new events (as shown in Figure 3) is only possible for registered users but any user can receive event notifications.

Once an event is in the system its information dissemination process begins. We implemented both a push and pull approach; in pushing event information we use an Android service that generates notifications to the phone whereas in the pulling approach the application polls the server for new events at regular intervals. Of course, the actual dissemination method depends on user preferences and device capabilities; to increase receivers, text messages and IVR can be easily implemented via other means.

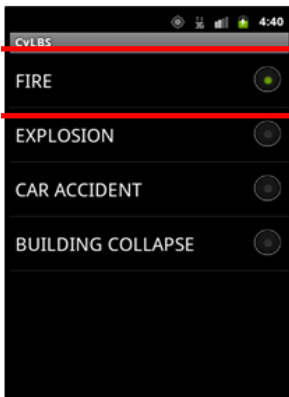

Figure 3. Reporting a new event

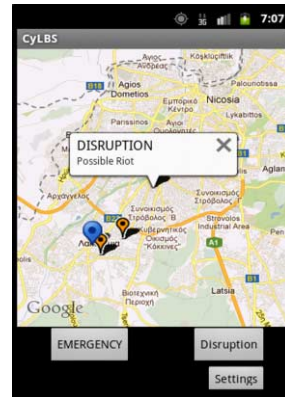

Figure 4. Displaying event information

In figure 4 we see an instance of the application running and a number of events shown on the map; the user has opted to get more information on a particular event and the relevant popup has appeared. It is important to note the word ‘possible’ in the event description which has a dual purpose: to warn users that the information may be inaccurate but at the same time encourage them in a way to also report the event (if they have observed it) and thus enable the system algorithms to verify it and assess its impact. In the opposite case, users may indicate that an unverified event does not exist. Also note that users have the option to notify the system that an event is no longer valid and it should be removed to avoid sending any false notifications to users approaching its area; this can be particularly useful in periodic disruptions e.g. heavy traffic.

One issue of concern in Location Based Services involves user privacy. To alleviate such an issue, users have the ability to select the level of personal location information they provide to the service. Inevitably service personalisation, which in our case entails the ability to receive only the events from the geographical area around a user, implies that the location of the user is provided to the system. On the other hand, users not willing to reveal their location to the system will receive information on all events irrespective of geographical area. This comes at the expense of additional network data traffic as well as extra data and map processing on the mobile device.

3. Conclusion and future work

In this paper we presented the main aspects behind the implementation of a system for emergency event information gathering and dissemination through the use of smartphones. The main purpose is to facilitate fast and accurate reporting of events from members of the public and decisions as to who and when to notify concerning those events. Warning people approaching an area of an incident can prevent further dangers and inconvenience. During the implementation we paid particular attention to user preferences as well as privacy concerns; event filtering can take place at the service provider or locally at the end user's device.

Note that we are purposefully concentrating on emergencies and disruptions; the system can be easily extended to cover other forms of location-based notifications. In some situations our system may act as complementary and exchange data with other systems (e.g. traffic monitoring). Within future work we will attempt to identify the best methodologies for event verification detection of event termination.

References

- [1] Georgia Tech Emergency Notification System. Online: <http://www.gatech.edu/emergency/>
- [2] M.Labrador, K.Michael and A.Kupper. Advanced Location-Based Services. In *Computer Communications*, 31(6), 2008, 1053-1054.
- [3] A.Malizia et al. An emergency notification system for all. In *Proceedings of the 6th ISCRAM conference*, Gothenburg, Sweden, May 2009.
- [4] B.Raynolds and M.Seeger. Crisis and emergency risk communication as an integrative model. In *Journal of Health Communication*, 2005, DOI: 10.1080/10810730590904571
- [5] Reverse 911: Interactive Community Notification Online: <http://www.reverse911.com>
- [6] K.Seada and A.Helmy. Geographic rendezvous-based architectures for emergency data dissemination. In *Wireless Communications and Mobile Computing*, Wiley InterScience, 2008.
- [7] N.Shiode et al. The Impact and Penetration of Location-Based Services. In: Karma H. & Hammad A. (eds.), *Telegeoinformatics: Location Based Computing and Services*. CRC Press. 2004, 349-366.
- [8] K.Starbird. Digital Volunteerism During Disaster: Crowdsourcing Information Processing. In *Proceedings of the ACM Conference on Human Factors in Computing Syst.*, Vancouver, Canada, 2011.
- [9] L.Lambrinos and C.Djouvas. "Using location information for sophisticated emergency call management." *Wireless Mobile Communication and Healthcare*. Springer Berlin Heidelberg, 2011.
- [10] The Ushahidi platform. Online: <http://www.ushahidi.com>
- [11] K.Boulos et al.: Crowdsourcing, citizen sensing and sensor web technologies for public and environmental health surveillance and crisis management: trends, OGC standards and application examples. *International Journal of Health Geographics* 2011
- [12] Goodchild, Michael F. and Glennon, J. Alan(2010) 'Crowdsourcing geographic information for disaster response: a research frontier', *International Journal of Digital Earth*, 3: 3, 231 — 241, 2010

‘Soundwalk’: An embodied auditory experience in the urban environment

Katerina Talianni^a, and Dimitris Charitos^{b1}

^a*National and Kapodistrian University of Athens, Greece*

^b*Department of Communication and Media Studies
National and Kapodistrian University of Athens
Athens, Greece*

Abstract. Mobile and locative media are systems of technologically mediated communication providing the opportunity to relate physical environments with digital information in order to create “hybrid” spatial experiences, which may function as the context for cultural activities. This has led to new ways of creating, representing and communicating meaning in relation to space and consequently to emergent artistic practices. At the same time, the emerging field of urban informatics addresses novel ways of interacting with our cities and their digital content. Mobile sound art, at the intersection of these technological innovations, deals with the urban environment as a musical interface and employs mobile devices that offer new possibilities for artists to actively involve their audiences. This paper focuses on the soundwalk, as a subspecies of mobile sound art, and attempts to shed light on the relationship between sonic artistic practices and the everyday mobile communication experience by investigating specific examples of this art form.

Keywords. Mobile sound art, soundwalk, urban computing, hybrid spaces.

Introduction

The emergence of web 2.0 tools, such as social networking sites, blogs, wikis, podcasts and web applications has introduced a more collaborative and interactive Internet experience, where the role of creating and publishing content is no longer the privilege of the few but potentially of any web user. Nowadays, this technology is also available for mobile phones, which are evolving from devices for one-to-one communication to powerful (wirelessly) networked computers, supporting social interaction while being mobile.

Advanced sensing systems and location-detection technologies are providing personal mobile communication devices with the ability to gather contextual information which may subsequently affect the course of the content presentation and in general the act of communication that these systems support. The use of mobile computing, wireless networks, and digital media for the purpose of associating information and meaning with geographic locations via location-detection technologies, has led to the concept of locative media [32]. Mobile and locative media (LM) are therefore systems of technologically mediated communication providing the

¹ Corresponding Author: Dimitris Charitos, Department of Communication and Media Studies, National and Kapodistrian University of Athens. Email: vedesign@otenet.gr

opportunity to relate physical environments to digital information in order to create “hybrid”² spatial experiences, which may function as the context for social and cultural activities. The use of these media has already resulted in new ways of creating, representing and communicating meaning in relation to space and consequently to emergent artistic practices.

New media theorists are currently discussing the nature and characteristics of the emergent ‘pervasive’ media environment, in which all media may become available on a variety of wireless platforms and devices ([21], p.32). This technological infrastructure supports advanced interaction, the potential of collaboration amongst users, personalization and most importantly affords the possibility of new forms of social interaction which may take place in the urban context. Indeed, mobile and location-based systems are seen as supporting novel and revolutionary new ways of inhabiting urban spaces and therefore their emergence and their potential impact on social interaction in the urban context suggests that new conceptual models regarding the design of such hybrid, dynamically evolving environmental experiences are needed. Consequently, the resurgent field of urban informatics addresses novel ways of interacting with our cities and the layers of digital content with which these cities are augmented and investigates the transformation of everyday life as a result of the introduction of the aforementioned techno-social systems.

This paper, discusses one type of emergent artistic practice supported by the aforementioned media, mobile sound art, and attempts to understand “how the power of social technologies can be harnessed for social engagement in urban areas” [14]. For this purpose, it explores the soundwalk, as a subspecies of mobile sound art at the intersection of sound art, mobile communication and artistic practice. The soundwalk is perceived by sound artists and musicians as an auditory experience which may mobilize urban space. The purpose of this paper therefore is to shed light on the relationship between sonic artistic practices and the everyday mobile communication experience, by investigating how sonic artists and mobile audio application developers have implemented their vision of a ‘sociable smart city.’

1. Emergent artistic practices using mobile and locative media

Location-based systems and media provide the ability to situate information, as well as the mediated interpersonal communication process, onto physical space. By supporting synchronous or asynchronous communication amongst multiple remotely situated participants, this form of mediated communication potentially affords physical proximity in real space. The combination of these elements provides participants with a new hybrid spatial experience [12]. Souza e Silva defines a hybrid space as “a conceptual space created by the merging of borders between digital and physical spaces, because of the use of mobile technologies as social devices. Nevertheless, a hybrid place is not constructed by technology. It is built by the connection of mobility and communication and materialized by social networks developed simultaneously in physical and digital spaces ([27], pp. 265-266).”

² The paper discusses systems which afford a hybrid (virtual as well as physical) spatial experience. For a more complete definition of the term “hybrid space” see Kluitenberg (2006) [19] and Souza e Silva (2006) [27].

Augmented and mixed-reality technologies merge the physical and the digital sphere making them coexistent in the same environment. Layers of physical and digital space give rise to researchers' visions about the cities of tomorrow, described in different ways as 'Networked Cities' [23], 'Mediascapes' [24], 'Hybrid Space' [27] or 'Hybrid Spaces' [26], 'Sentient Cities' [13], 'Augmented Cities' [1], 'Real-Time City' [31], 'Network Landscapes' [25], or 'Wikicities' [11], in relation to the fields of ubiquitous computing and urban informatics [14].

The resulting communicative experience may enable the diversion and re-appropriation of social space, thus serving the emerging needs of city dwellers and affording novel ways of public activity. However, the manner in which communication via LM may enrich the ways we interact with other people and the environment is not yet fully understood. The use of LM in emergent artistic practices may reveal ways of using these media not only as services and commodities but also as systems mainly geared towards supporting communication, spatial awareness and collaborative location-specific activities. LM systems are shaped and evolve within the urban spatial context. Thus, they may result in the creation of digital representations of the city that are continuously augmented with the lived experience of its inhabitants, as indicated by the digital "traces" of their movement and action.

Location-based technologies and services may differ significantly in the way they are designed and structured. They can have a hierarchical top-down structure or they can be bottom-up frameworks and open systems for exchanging content. Artists use location-aware and ubiquitous technologies to create artistic interventions which aim to reconfigure our understanding of their use and to question the way they may affect everyday life in the city. Apart from their aesthetic value, LM artworks may also result in raising public awareness on various issues such as surveillance, the tracking of human bodies and objects, location detection, the process of map making and the ability to form social networks in the city.

Bourriaud ([8], p. 28) notes that artistic activities since the early 1990s indicate a shift of focus of artistic practice towards the sphere of inter-human relations. Indeed many artists have focused on creating artworks which provide novel social experiences ([8], pp.14-18). In his discussion of contemporary art practice, Bourriaud suggests that "art is the place that produces a specific sociability...Over and above its mercantile nature and its semantic value, the work of art represents a social interstice...a space of human relations...the contemporary art exhibition creates free areas and time spans, whose rhythm contrasts with those structuring everyday life, and it encourages an inter-human commerce that differs from the "communication zones" that are imposed upon us...Art is a state of encounter" ([8], pp.16-18).

However, Kraan ([20], p. 46) suggests that artists have so far made limited use of LM to bring about location-specific social activities that focus on initiating inter-human relations. This has so far been achieved mostly by commercial applications of location-based services. These services rely on a user/consumer model and are meant to satisfy the users' needs or even create new ones, resulting in increased profit for private telecommunication providers. On the other end, artistic approaches of LM are primarily motivated by a more creative and open vision for these techno-social systems and by the prospect of illustrating the complexity and richness of culturally constructed space [30].

2. Brave New Mobile World

Mobile (phone) music belongs to the tradition of sound and media art. Sound art, positioned between fine arts and music, has 'displaced' music from the traditional performance space, marking the end of the distinction between active artist and passive audience. However, mobile music goes a step further, as developments in technology, which brought the ubiquitous networking in everyday life, have changed the technological, social and geographical context. Therefore, it may be regarded as a new art form that positions the presentation of and the interaction with musical content in any physical space (urban or landscape), with the support of mobile communication technology, thus escaping the traditional context where performances occur, such as concert halls, and 'spills out' in the streets [4].

Mobile music emerges at the intersection of ubiquitous computing, mobile audio technology and NIME (New Interfaces for Musical Expression) [16]. The term mobile music includes every musical activity using portable devices that are not affiliated with a fixed unit, and it extends in creating, editing and sharing music on the move [6]. Mobility, the main characteristic of mobile music, "allows NIME concepts to occupy exterior urban space and exploit people's movement through it, as well as the heterogeneous space and social dynamics found in those environments" [16]. Moreover, the introduction of mobility reveals a need to re-examine the role of space in mobile music and sound art in general, since it involves users into acting and thus dynamically exploring the mobile audio environment, thereby increasing the power of new forms of musical experience.

From a technological perspective, the convergence of networked digital technology on mobile devices still poses many challenges and its implementation is in need of improvement. However, this study focuses more on the geographical and social aspects of creating such artistic interventions, than the supporting technological framework, since physical presence in a specific place is not necessarily needed because the mobile telephone is located in the pocket of the user. This fact may potentially disconnect the act of perceiving the artwork from the performance space. Nevertheless, as we can see in the majority of mobile music works, artists render locality a crucial element of the work [4]. The majority of mobile music and sound art works are "concerned with the urban environment as a musical interface. Location-aware sound art, audio annotation of physical space, and other creative applications" [18] echo the traditions of locative, sound and public art, three relevant art forms which consider site-specificity as a central parameter of the creative process.

Behrendt³ has proposed a classification of mobile music works into four main categories: 'Placed Sounds', 'Sound Platforms', 'Sonified Mobility' and 'Musical Instruments' [4]. She focuses on the relationship of the geographical, social and technological context of mobility as a framework for the development of the methodology she employs and attempts to classify the particularities of mobile sound and multimedia experiences. In the first category of 'Placed Sounds', the projects involve specific sites that are selected by the artist and the participants experience in situ their own versions or remixes of tracks depending on the route they choose to follow and the time they spend on the track. The second category of 'Sound Platforms' comprises mobile music works where the audience, using a special platform, must

³ Behrendt has published various papers on the topic of mobile sound art [5, 6, 7] and has completed her PhD thesis on the subject, under the title: "*Mobile Sound: Media Art in Hybrid Spaces*".

choose and edit sounds and connect them with locations. The 'Sonified Mobility' category includes projects that use the movement of the participants within space and translate it to sound, creating a dialogue between movement and the urban landscape. The fourth category, 'Musical Instruments', includes applications developed for mobile phones and comprises works that reuse existing mobile media - especially mobile phones - like musical instruments.

A common feature of mobile sound art works is the exploitation of the mobile nature of these technologies as a key part of the project. All four categories, 'Placed Sounds', 'Sound Platforms', 'Sonified Mobility' and 'Musical Instruments', have in common the engagement with a mobile communicative experience in the urban, networked public space. Mobile music and sound art works propose a use of sound in public space which is neither commercialized (eg Muzak), nor individualistic (eg iPod) [9].

3. Soundwalks and the City

The variety of already implemented mobile music projects offers valuable insights into the auditory dimensions of public spaces. A popular mobile sound art subspecies of the first category of 'Placed Sounds', which deals with the relationship between listeners and their surrounding sonic environment, is the soundwalk. The term was used by the Canadian composer R. Murray Schafer⁴: "Soundwalking is a creative and research practice that involves listening and sometimes recording while moving through a place at a walking pace. Soundwalks take the everyday action of walking, and everyday sounds, and bring the attention of the audience to these often ignored event practices and processes [22]." In recent years, there has been an increase in soundwalk projects by urban sonic research groups probably due to the fact that the creation of such an activity is significantly aided by the aforementioned mobile audio technologies. Taking into account the characteristics and the dimensions chosen to be brought forward by the artist, this paper proposes the following categorization of soundwalks, according to the role that sound plays in the overall experience:

- 'Sonic Memorial Soundwalks',
- 'Music Routes' and
- 'Augmented Sound Games'.

The projects of the first category, 'Sonic Memorial Soundwalks' are dealing with cultural heritage and aural history as they invite participants to listen to places and people that don't exist anymore, therefore we can describe them as historic or mnemonic listening. Memory has long been intimately related to topography and place ([10], p.894), and by adding a layer of aural information participants can make imaginative associations to the history of the place, in an embodied, active and multisensory way. An example of this category, is the project 'Sidney Sidetracks' (2008) by Australian Broadcasting Operation (ABC), which draws on the ABC's sound archives, recorded on location during different moments of a site's history, in order to generate different ways of experiencing contemporary spaces in central Sydney. These past auditory traces, available on mobile platforms, are used to frame a particular auditory encounter with the same sites today [2]. This 'auditory turn', shifting the

⁴ R. Murray Schafer and his colleagues of the World Soundscape Project in the 1970s at Simon Frith University initiated the study of Acoustic Ecology.

attention from the visual to the aural dimension serves as an alternative methodology for approaching the cultural walk.

In the category of 'Music Routes', recordings of specific places in a city are used to create a musical composition intended to be listened to with the help of a mobile device. While users move in a specific route, they associate the sounds that they hear in their headphones with the sounds coming from the external environment. The 'Music Route' is adding a layer of sonic experience as a means of increasing participants' engagement with their environment, provoking a dialogue between them. As an example of this category, the project titled "There to Hear: Reimagining Mobile Music and the Soundscape in Montreal" by Samuel Thulin, imaginatively reframes the city's soundscape. Field recordings of a specific route in the city of Montreal are used for the musical composition, intended to be listened to while moving in the specific route [28]." Thulin's approach to the use of mobile music devices contends Bull's work stating that: "the iPod user struggles to achieve a level of autonomy over time and place through the creation of a privatized auditory bubble ([9], 344)." In Thulin's mobile music, listeners, instead of being disconnected and separated in their 'bubble', they remain connected to their environment. His research is inspired by the work of David Beer, who notes the persistence of sounds of the city even while someone is listening to headphones, stating: "This may even form new and distinct experiences of the music as it intermingles with the hum of the city and the places the listener moves through ([3], 859)."

In the third category, 'Augmented Sound Games', the soundwalk is constructed in a playful way and guided by a mobile phone application. An emerging trend among mobile audio apps is the exploration of how audio content can be connected in various ways to aspects of place. These applications operate with sounds picked up by a microphone, for instance, which are processed in real-time with effects such as echo or reverb and mixed with the music in the headphones. As a result, the user is immersed in an augmented acoustic experience provided by a variety of ways in which the audio content might change, depending on the physical environment surrounding her. As an example of the third category, 'Dimensions: Adventures in the Multiverse' app, by Reality Jockey Ltd., is a "sonic adventure game" that invites users to explore an audio landscape with the purpose of collecting artifacts. 'Dimensions'⁵ is "a mind bending game that uses Augmented Sound" for a "unique immersive gaming experience [33]." The developer and RjDj's founder Michael Breidenbrucker, describes it as "a highly crafted, artistic piece" [34]. Although the game doesn't allow user's participation in the production of the scenes, by recording and uploading their own audio mixes, it engages users into interacting with the scenes, thus affording an immersive experience [29].

4. Conclusions

With the aid of mobile pervasive and locative media, space is being hybridized as the mediated spatial experience that is mapped onto the physical urban environment, allows for new kinds of collaborative activities and social interaction. Thus, the experience of urban space may be augmented by multiple layers of multisensory stimuli and information. The application of the aforementioned media to the development of city network infrastructures that reform and enhance citizen's relation

⁵ According to the description of 'Dimensions' on the iTunes store.

to urban space is potentially accessible to all participating mobile users. However, apart from designing and constructing digital, smart cities affording artifacts and services as commodities, it is also important to ensure that the available technological infrastructures are also used for building social interactions between them and the people that inhabit them. Social media and digital communication technologies have so far enabled people to interact with their cities in novel ways and have made new cultural experiences possible.

This paper presented and discussed works of mobile sound art in an effort to analyze how artists and mobile audio applications developers have so far realized the "sociable smart city". Their works resonate their perception of the city and afford potential users with a hybrid spatial experience. In the beginning of the paper, the genre of mobile music and its characteristics was briefly discussed, highlighting the fact that mobile sound art works explore sonic interactions with urban spaces with the shift from visual to aural experience, augmenting urban spaces. Then, a more specific subspecies of sound art, the soundwalk has been discussed. Soundwalks deal with the idea of "the city as interface and mobility as musical interaction, allowing everyday experience to become aesthetic practice [4]." The paper has proposed a categorization of soundwalks into three categories and has attempted to use few specific examples of such artworks for the purpose of explaining how people interact with their environment while experiencing these mobile artistic interventions.

A key feature of the works discussed above, and also of all works of mobile music and sound art is immersion. The listener-participant enters a new augmented dimension immersed in sound and media, while at the same time navigating within the urban environment, which is "increasingly conceptualized as a complex techno-social network" [15], and thus experiencing it in new ways. One central issue in the process of creating these artistic interventions is the quality of the immersive experience they afford. The use of mobile media such as cell phones as platforms for artistic creation [17] is the key to the transfiguration of the everyday experience into an embodied aesthetic practice, performed in a 'hybrid space'.

Finally, a common factor in all works of mobile sound art is interaction, the active participation of the user that takes place in everyday life contexts. Interaction is a central element of mobile sound art works and available technologies may allow the audience, to a greater or lesser extent, to affect and shape the presentation of the audio content, through interacting with it, with the urban space and with other members of the audience. Mobile music and sound art works and audio applications for smartphones are exploring sonic aspects of spatial perception, providing an alternative approach to the linear understanding of time and the Cartesian conception of space. This embodied active and multisensory experience that renders audience participation a crucial element of an artwork or a mediated activity, could be seen as the main impact of urban computing on cultural citizenship in the case of these artistic activities. How audience interaction will affect and co-produce mobile music and sound art works, is yet to be explored.

References

- [1] A. Aurigi, F. De Cindio, eds, *Augmented urban spaces: articulating the physical and electronic city*, Ashgate Publishing, Hampshire, 2008.

- [2] S. Barns, Sydney Sidetracks: Listening in to 'history where it happened' using the ABC's television and radio archives, *Australia and New Zealand Communications Association conference Communication, Creativity and Global Citizenship, Brisbane, July 2009*, Retrieved April 20, 2013, from http://www.dev.internet-thinking.com.au/anzca_x/images/stories/past_conferences/ANZCA09/barns_anzca09.pdf.
- [3] D. Beer, Tune out: Music, soundscapes and the urban mise-en-scene, *Information, Communication & Society* 10, 6 (2007), 846-866.
- [4] F. Behrendt, "Mobile sound: media art in hybrid spaces", PhD diss., University of Sussex, 2010.
- [5] F. Behrendt, Texting and Calling Public Spheres: Mobile Phones, Sound Art, and Habermas, *After the Mobile Phone? Social Changes and the Development of Mobile Communication*, 2008, pp. 35-54.
- [6] F. Behrendt, *Sound Art on the Move*, Paper presented at SoundAsArt :: Blurring of the Boundaries, University of Aberdeen, Aberdeen, Scotland, UK, November, 2006, Retrieved April 20, 2013, from <http://www.soundartarchive.net/articles/Aberdeen%20-%20Frauke.pdf>.
- [7] F. Behrendt, From calling a cloud to finding the missing track: Artistic approaches to mobile music, *Proceedings of the 2nd International Workshop on Mobile Music Technology*, 2005.
- [8] N. Bourriaud, *Relational aesthetics*, Dijon-Quetigny: Les presses du réel, 2002.
- [9] M. Bull, No dead air! The iPod and the culture of mobile listening, *Leisure Studies* 24, 4 (2005), 343-355
- [10] T. Butler, A walk of art: the potential of the sound walk as practice in cultural geography, *Social & Cultural Geography* 7, 6 (2006), 889-908.
- [11] F. Calabrese, K. Kloeckl, and C. Ratti, Wikicity: Real-time location-sensitive tools for the city, *Handbook of research on urban informatics: The practice and promise of the real-time city* (2008), 390-413.
- [12] D. Charitos, Precedents for the design of Locative Media, *Future Interaction Design II*, eds. Saariluoma, P. & Isomäki, H, Springer Verlag, London, 2008.
- [13] M. Crang, S. Graham, SENTIENT CITIES Ambient intelligence and the politics of urban space, *Information, Communication & Society* 10, 6 (2007), 789-817.
- [14] M. Foth, *From social butterfly to engaged citizen: urban informatics, social media, ubiquitous computing, and mobile technology to support citizen engagement*, MIT Press, USA, 2011.
- [15] M. Foth, J. Choi, C. Satchell, Urban informatics, *Proceedings of the ACM 2011 conference on Computer supported cooperative work*, pp. 1-8. ACM, 2011.
- [16] L. Gaye, L.E. Holmquist, F. Behrendt, A. Tanaka, Mobile music technology: report on an emerging community, *Proceedings of the 2006 conference on New interfaces for musical expression*, pp. 22-25. IRCAM—Centre Pompidou, 2006.
- [17] L. Kaye, *YOU ARE HERE: Binaural Audio, Mobile Media and the Sonic Exploration of Urban Space*, Retrieved April, 20, 2013, from <http://wi.mobilities.ca/you-are-here-binaural-audio-mobile-media-and-the-sonic-exploration-of-urban-space/>
- [18] N. Kirisits, F. Behrendt, L. Gaye, A. Tanaka, *Creative Interactions-The Mobile Music Workshops 2004-2008*, University of Applied Arts Vienna, Vienna, Austria, 2008.
- [19] E. Kluitenberg, The Network of Waves: Living and Acting in a Hybrid Space, *Open* 11 6 (2006), 6-16.
- [20] A. Kraan, To Act in Public through Geo-Annotation: Social encounters through Locative Media Art in Hybrid Space: How wireless media mobilize public space, *Open* 11, 6 (2006), 38-47.
- [21] M. Lister, *New media: A critical introduction*. Taylor & Francis, US, 2009.
- [22] A. McCartney, Soundwalking: creating moving environmental sound narratives, *Viitattu*, 20 (2010), Retrieved April 20, 2013, from <http://soundwalkinginteractions.wordpress.com/2010/09/27/soundwalking-creating-moving-environmental-sound-narratives/>
- [23] W.J. Mitchell, *Me++: The cyborg self and the networked city*, MIT Press, USA, 2003.
- [24] J. Reid, K. Cater, C. Fleuriot, R. Hull, Experience design guidelines for creating situated mediascapes, *Mobile and Media Systems Laboratory, HP Laboratories Bristol* (2005).
- [25] T. Rueb, Network Landscape, *ISEA 2011 Istanbul-Portal*, 2011.
- [26] J. Seijdel, Hybrid space: How wireless media mobilize public space, *Open 11, NAi Publishers, Rotterdam*, 2006.
- [27] A. de Souza e Silva, From Cyber to Hybrid, *Space and Culture* 9, 3 (2006), 261-278.
- [28] S. Thulin, 'There to Hear': Reimagining Mobile Music and the Soundscape in Montreal, Retrieved April 20, 2013, from <http://www.inter-disciplinary.net/wp-content/uploads/2011/04/thulinpaper.pdf>
- [29] S. Thulin, *Mobile Audio Apps, Place and Life Beyond Immersive Interactivity*, Retrieved April 20, 2013, from <http://wi.mobilities.ca/mobile-audio-apps-place-and-life-beyond-immersive-interactivity/>
- [30] A. Townsend, Locative-Media Artists in the Contested-Aware City, *Leonardo* Vol.39, 4, (2006), 345-347.
- [31] A. Townsend, (foreword) in Foth, Marcus, *Handbook of research on urban informatics: The practice and promise of the real-time city*, Information Science Reference, IGI Global, 2009.

- [32] M. Tuters, *The locative commons: Situating location-based media in urban public space*. Paper presented at the 2004 Futuresonic Conference. Manchester, UK, 2004, Retrieved May 10, 2005, from http://www.futuresonic.com/futuresonic/pdf/Locative_Commons.pdf
- [33] https://itunes.apple.com/us/app/dimensions-game-new_experience/id473626010?mt=8
- [34] <http://www.wired.com/underwire/2011/12/rjdj-dimensions-app/>

Keynote: Open UBI Oulu

Timo OJALA¹

Department of Computer Science and Engineering, University of Oulu, Finland

Contemporary urban landscape is being pervaded by various forms of ubiquitous computing ('ubicomp') technologies. They provide new opportunities and challenges for the interaction with their inhabitants -essentially turning urban spaces into smart environments. However, cities as smart environments remain largely unexplored research wise, with smart cities' impact on people's daily lives much less prevalent than that of mobile and personal devices [1]. A smart city can be regarded as a highly complex, orchestrated, co-operative and coordinated "ensemble of digital artifacts". Their research is moving away from single user or small user group systems towards complex sociotechnical systems as large-scale deployments of pervasive computing infrastructure for larger populations [2].

Despite 20 years of well-resourced ubicomp research, few visible and lasting contributions to the urban digital fabric have emerged. This lack of progress has triggered criticism on how research is conducted. Due to the high cost and efforts involved in setting up and maintaining real world installations for real people, ubicomp research has been mostly lab-based. Emerging real world ubicomp system studies dubbed as "in the wild" are still predominantly short-term and small-scale. Thus, they fail to establish the technical and cultural readiness and the critical mass of real users that are required before a system can be evaluated (un)successful [3].

Current "in the wild" ubicomp studies face also a number of methodological and theoretical challenges. First, the role of ubicomp systems as integral elements of urban landscape is not well understood [4]. Second, the current understanding of "wild practices" is seriously lacking [5]. Third, we do not have working approaches for reliably evaluating ubicomp systems in real-world settings. To address these gaps and to study the big effects of ubicomp technologies, we need a much wider and longitudinal access to large-scale real-world ubicomp installations, in order to significantly advance our understanding of the design, practices, and evaluation of ubiquitous interactions in city-scale smart environments.

For this purpose the multidisciplinary UBI (UrBan Interactions) research program (<http://www.ubioulu.fi/en/>) coordinated by the University of Oulu has invested, together with the City of Oulu, several millions of euros into pervasive computing infrastructure deployed around downtown Oulu [6]. The infrastructure includes for example a municipal WiFi network providing open and free Internet access to the general public [7], a network of large interactive public displays at pivotal indoor and outdoor locations around Oulu [8], and an emerging collaborative 3D virtual model of downtown Oulu. The resulting Open UBI Oulu civic laboratory facilitates both

¹ Corresponding Author: Timo Ojala, Department of Computer Science and Engineering, University of Oulu, Finland. Email: timo.ojala@ee.oulu.fi

controlled small-scale short-term research experiments and a longitudinal provisioning of a wide range of novel ubicomp services to the general public in authentic urban setting, thus establishing the needed technical and cultural readiness and the critical mass of real users. By monitoring the usage of services and people's interaction with them we obtain high quality research data on ubiquitous interactions, generated by real people using services at their own out of their own will. Thus, the data is not contaminated by staging, observer effects and demand characteristics so typical for lab studies conducted with recruited test users. The City of Oulu is our civic laboratory, and vice versa, our civic laboratory is an indistinguishable part of the urban fabric of the City of Oulu.

The talk discusses the infrastructure deployment, describes selected research case studies such as employing interactive displays to bootstrap the civic engagement of the young [9], configuring Bluetooth access points around Oulu to conduct unsolicited proximity marketing for the purpose of recruiting blood donors [10] and sensing the city [11], and concludes with outreach activities making the infrastructure available to other researchers [12] and the challenges of this type of "in the wild" research.

Bio

Timo Ojala is a Professor of Computer Science and Engineering and the Director of the MediaTeam Oulu research group at the University of Oulu, Finland. He leads the multidisciplinary UBI (UrBan Interactions) research program that together with the City of Oulu has deployed the Open UBI Oulu civic laboratory at downtown Oulu for studying ubiquitous computing and urban informatics in authentic urban setting with real users. He has authored about 130 papers on ubiquitous computing, urban informatics, HCI, networking, multimedia and pattern recognition, including the most cited ICT related paper in Finland since 2002. He is the founding co-chair of the International Conference on Mobile and Ubiquitous Multimedia (MUM) and served as the General Chair of MUM 2007. He obtained his M.Sc. and Dr.Tech. degrees from the University of Oulu in 1992 and 1997, respectively. He is a member of the ACM and the IEEE.

References

- [1] Schmidt A (2010) Ubiquitous Computing: Are We There Yet? *Computer* 43(2):95-97.
- [2] Ferscha A (2012) 20 Years Past Weiser: What's next? *IEEE Pervasive Computing* 11(1): 52-60.
- [3] Greenberg S & Buxton B (2008) Usability evaluation considered harmful (some of the time). *Proc. CHI 2008, Florence, Italy*, 111-120.
- [4] Kostakos V, O'Neill E & Penn A (2006) Designing urban pervasive systems. *Computer* 39(9):52-59.
- [5] Rogers Y (2011) Interaction Design Gone Wild: Striving for Wild Theory. *Interactions* 18(4): 58-62.
- [6] Ojala T, Kukka H, Heikkinen T, Linden T, Jurmu M, Kruger F, Sasin S, Hosio S & Narhi P (2010) Open urban computing testbed. *Proc. TridentCom 2010, Berlin, Germany*, 457-468.
- [7] Ojala T, Orajarvi J, Puhakka K, Heikkinen I & Heikka J (2011) panOULU: Triple helix driven municipal wireless network providing open and free Internet access. *Proc. 5th International Conference on Communities & Technologies (C&T 2011), Brisbane, Australia*, 118-127.
- [8] Ojala T, Kostakos V, Kukka H, Heikkinen T, Linden T, Jurmu M, Hosio S, Kruger F & Zanni D (2012) Multipurpose interactive public displays in the wild: Three years later. *Computer* 45(5):42-49.
- [9] Hosio S, Kostakos V, Kukka H, Jurmu M, Riekkii J & Ojala T (2012) From school food to skate parks in a few clicks: Using public displays to bootstrap civic engagement of the young. *Proc. Pervasive 2012, Newcastle, UK*, 425-442.
- [10] Ojala T, Kruger F, Kostakos K & Valkama V (2012) Two field trials on the efficiency of unsolicited Bluetooth proximity marketing. *Proc. MUM 2012*, article no. 38.
- [11] Kostakos V, Juntunen T, Goncalves J, Hosio S, Ojala T (2013) Where am I? Location archetype keyword extraction from urban mobility patterns. *PLoS ONE* 8(5): e63980.
- [12] Ojala T & Kostakos V (2011) UBI Challenge: Research cooperation on real-world urban computing. *Proc. MUM 2011*, 205-208.

Keynote: Multiplayer Sensor-Based Games Used in Public Spaces

Irene MAVROMMATI¹

School of Applied Arts, Hellenic Open University, Greece

Abstract. A new social form of play is been formed that involves large number of participants as players engaged simultaneously in public areas. A software/hardware platform that allows for the creation of interactive installations in public spaces is The FinN platform, that provides high accuracy in detecting and localizing people, by requiring players to carry identifying devices; facilitated by the sensor-bouquet of the devices offer possibilities for rich gesture interaction. Several games are developed with the FInN platform using open source technologies and presented in a series of public events, thus providing a source for several observations regarding the games characteristics.

¹ Corresponding Author: Irene Mavrommati, Hellenic Open University, Patras, Greece, Email: mavrommati@cap.gr

This page intentionally left blank

1st International Workshop on Intelligent Users, Intelligent Cities (IU/IC'13)

Efpraxia D. Zamani (Athens University of Economics and Business,
Greece)

Eleni N. Mitakou (National Technical University of Athens, Greece)

Paraskevi G. Fanou (National Technical University of Athens, Greece)

Dimitris M. Hatzopoulos (Architects Association of Thessaloniki,
Greece)

This page intentionally left blank

Introduction to the proceedings of IU/IC 2013

The ‘Intelligent Users/Intelligent Cities’ workshop focuses on user behavior and familiarization with intelligent systems, as well as the latter’s integration within the urban space. In particular, it tries to identify techniques, which, through the examination of the characteristics of the user of the smart city, will make relevant and interpretable the way the city is transformed into the smart and augmented city of the future. As such, the main goal is to examine how computing is weaved together with the urban environment and the everyday life of habitants.

Several studies to date have investigated these aspects; yet the main question regarding the role of the man of the networks era, remains. Using as the main methodological instrument the screen of cinematography, we investigate the shift of the city user behavior, from viewer to act(or). The user of the intelligent city does not only observe but also reacts and interacts, receives and transmits information. This selection of papers, that will complement the discussion of this workshop, place at the center of attention the citizen and through her/his characteristics attempt to ‘read’ the city. The main issues under investigation are the interaction between the designer and the scripting environments, the shift of focus from subject to object thanks to Computer-Assisted Conception and Fabrication systems (CFAO). In a world of ubiquitous computing technologies, the authors embark upon exploring how critical design research may inform the process of designing intelligent objects. In addition, another issue approached within the context of the workshop is the non-linearity of ‘reading’, i.e., the concept of cyberspace and how it is projected onto the ‘reading’ of the real city, as well as how the existence of a new digital layer, added on top of the urban reality, which is nowadays common place and self-evident, dictates its close examination. On the other hand, some authors discuss the evolution of the ‘digital city’ concept and the emersion of intelligent environments. Finally, the workshop is enriched by two, quite different, approaches; the first proposes the provision of innovative, personalized services to citizens that enhance everyday life through modeling context and fuzzy personas, while the second focuses on the formation of a network of spaces, contributing to the activation of public space and its transformations.

We believe that the selected studies will spark the interest of the participants and the academia at large, and that the Workshop as a whole will generate thought-provoking discussions, giving everyone inspiration for further research.

We would like to thank all the members of the Program Committee, who supported us throughout the period of organizing the Workshop, by helping us select the papers and proving insightful comments to help authors improve their contributions.

Efpraxia D. Zamani, Eleni N. Mitakou, Paraskevi G. Fanou and Dimitris M.
Hatzopoulos,
Co-chairs IU/IC’13

From Spectator to User, From Viewer to (Act)or

Eleni N. MITAKOU ^{a,1}, Paraskevi G. FANOUE ^a and Efpraxia D. ZAMANI ^b

^a *School of Architecture, National Technical University of Athens*

^b *Department of Management Science & Technology, Athens University of Economics and Business*

Abstract. Stephen Hawking, when introducing Krauss' 'The Physics of Star Trek', wrote that "[s]cience fiction (...) is not only good fun but it also serves a serious purpose, that of expanding the human imagination." In this paper, following a retrospective juxtaposition of the two last centuries' filmic production, we show how imaginary worlds have become conventional and familiar, while viewers have transformed from mere spectators to users of intelligent technologies. We also exhibit how this led to the emergence of a new generation of users, that of intelligent users, who are now both transmitters and receivers of information, and who perceive urban reality very differently from previous generations.

Keywords. Cinema, city, narrative, technology, information technology, intelligent user

Introduction

The city may be described by its physical parts (i.e., places) as well as by the human activities (e.g., going to work, to eat, out), the public events (e.g., festivals, demonstrations) and the intelligent systems (e.g., smartphones, sensors, antennas) informing and being informed by the activities taking place within the urban web/landscape.

Movies, as well as architecture, create a narrative, introduce sets of rules [2], which, when taken together, develop a paradigm. Documenting and analyzing these elements, we as architects are provided with a new vocabulary and set of tools for reinventing the physical space. The result is not an architectural object or a new movie but the narrative itself; a way of thinking on intelligent environments and a way of thinking on architecture.

This paper focuses on the similarities and differences of the various filmic eras, their impact on the everyday of cinema viewers and the adoption of intelligent technologies by contemporary city users as facilitated by the movies. Within this context, we narrate the progressive shift from the city user, the viewer and perceiver of urban representations of the beginnings of the previous century, to the intelligent user who acts and interacts with the urban context of today. Following a historical-based approach, we illustrate the affective impact of cinema onto the filmic audience and the latter's relationship to the technological achievements of each era. Our main objective is to approach contemporary city users and the way they adopt and assimilate the reality of the cinematic world, which, according to Baudrillard has already occurred: "cinema attempting to abolish itself in the absolute of reality, the real already long absorbed in cinematographic (or televised) hyperreality." [3].

¹ Corresponding Author, elenimitakou@yahoo.gr

1. Into the Movies

The big (cinema) screen is a medium through which one may understand and perceive the physical space and the built environment. Therefore, movies, regardless the genre they belong to or the audience they are addressed to, can always be seen as documents that reveal the spatial reality and the social structure of the time they were filmed.

Nevertheless, reality is always captured through the subjective eye of the camera, while, equally so, the viewer may freely interpret the ‘framed’ reality. As viewers, we have been trained for many years to perceive the cinematic reality as our own, trying to find or imagine our role in the story. We do so by substituting the protagonist, reliving the events, occasionally ignoring vague questions or even disregarding any unrealistic representations.

According to Schweinitz [4], cinema tends to create globally widespread visual imaginations, forms of expression and tendencies. Yet, the purpose of this study is not to examine the ways or the methods cinema achieves this. Instead, our hypothesis is, and whose validity we manage to exhibit, that the filmic production of a specific era, concerning a specific place, generates and transforms urban conscience and at the same time familiarizes the city user with technological advances; ultimately, the city user becomes accustomed to today’s intelligent environment with the help of the big screen.

An examination into user familiarization and urban conscience through the filmic production brings the focus of our attention to the ‘screen’ as a medium. The screen-based interaction, which computers and cinema both share, offers an important starting point for our reflection upon the embodied relationship between screen, spectator, and the onscreen computer user [5].

1.1. *The Train Effect*

Cinema has not been invented by the Lumiere brothers. A lot of memorable or forgotten, and sometimes even unappreciated people worked in order to create what the two brothers later named as cinematographer or cinématographe, i.e., the machine that records movement. Following the usual convention we will begin our story with them.

It is difficult for us, today, to understand the reactions and the emotions of those few, first, viewers of the films made by the Lumiere brothers. The two brothers photographed the world around them, creating their firsts ‘actuality’ films, in a way presenting a view of their life and their environment. Their first public screening is documented to have taken place on December 28th in 1895 at the Grand Cafe on Paris’ Boulevard de Capuchines, and the programme of short films included ‘La Sortie de usines Lumière’ (1894), ‘La Voltige’ (1895), ‘La Peche aux poissons rouges’ (1895), ‘La Debarquement du congres de photographie a Lyons’ (1895), ‘Les Forgerons’ (1895), ‘L’ Arroseur arrose’ (1895), ‘Repas de bebe’ (1895), ‘Place des Cordeliers a Lyon’ (1895), and ‘La Mer’ (1895). The number of invited guests was limited to 35 and among them was George Mellies. The reactions of those first spectators are not documented [6].

The next year, according to Loiperdinger [7], another Lumieres’ film, ‘L’Arrivée d’un Train en Gare de La Ciotat’ (1895), gave birth to the documentary film. The film shows, in only fifty seconds, a familiar experience for spectators: a train pulls into a station while the passengers go back and forth on the platform.

The reactions this time were recorded. Journalists of the time described the experience as “excitement bordering on terror”, which sometimes became panic [8].

The German Railway's customer magazine wrote that "[t]he spectators ran out of the hall in terror because the locomotive headed right for them. They feared that it could plunge off the screen and onto them", while Bernard Chardère noted in a succinct fashion that "[t]he locomotive frightened the spectators" [7]. Furthermore, Loiperdinger notes that Emmanuelle Toulet, in his book 'Birth of the Motion Picture' discusses that "[t]he amazement at seeing windswept trees and stormy seas is followed by naked horror when the train approaching the station of La Ciotat appears to move toward them" [9], while they highlight Noël Burch's, an American film critic, statement that, in 1896, the spectators "jumped up from their chairs in shock" [7].

In his study, 'Cinema's Founding Myth', Martin Loiperdinger highlights several interesting points, which caused the aforementioned reactions. For example, the cinematographic train was dashing towards its audience, in flickering black and white rather than in natural colors, neither in natural dimensions. In addition, the only sound present was the repetitive and monotonous clatter of the projector's sprockets engaging into short film's perforation. These elements lead the viewers to feel physically threatened, panicked and as a result, the short film had a particularly lasting impact [7]. The train effect quickly transformed into a myth, or a well spread story, and one may argue that it presents the basic force of cinema itself; when the lights turn off, the audience gets quiet and the projection begins, we, as viewers, enter the world of illusions.

1.2. Fear of Technology and Modernism: the Era of Optimism

Since the beginning of the previous century, architecture, as well as the other representative arts, started wondering about the then emerging proliferation of technology and the form of the city and the building in a technologically developed world (e.g., 'La Citta Nuova' in 1914 by Antonio Sant'Elia, 'Metropolis' in 1927 by Fritz Lang).

Gradually, the representative arts became a battleground for the new laws of urban perception, and the rising uncanny visions of a world, dealing with future problems, gave the reins of humanity to an unknown technologically driven force. The chaotic experience of spatial incoherence and disorientation – characteristics of the new technological metropolis – seemed to be the favorite subject of all the auteurs and creators.

In 'Metropolis', the director provides the viewer with a vision of the urban future, commenting on the relationship between the industrialization, the changes on the urban landscape and the social relations. This imaginary city is organized vertically, celebrating the modernist design and architecture as aesthetic possibilities [10].

The film begins with the two worlds, separated from each other, and where the working class inhabits the underground, degraded city, while the rich industrialists keep for themselves the garden city of the upper world [11]. However, the power of love is able to connect the two worlds (the ultimate intertitle reads "The heart connects the mind and the hand"). At the same time it resolves the problem of class exploitation [12].

Admittedly, the film offers a dystopic imagery of scientists and their laboratories, which was in any case the popular viewpoint of science and its creators at the particular period [13]. Nevertheless, the cityscape negotiates future possibilities, and its happy ending brings forth the era's optimistic vision towards the pressing questions imposed

by the technological achievements of the time and the masses' hope for a better tomorrow.

1.3. Seduced by the Modern City: the Screen as the Place You Want to Be

Eisenstein, the Soviet filmmaker and theorist, in his essay 'Montage and Architecture', first published in 1937, posited that there is a genealogical relation between architecture and cinema [14]. In more detail, the film spectator moves along an imaginary filmic path, travelling both in time and space. This opens up a possibility to perceive the filmic experience in a similar fashion to that of the consumer of architectural space, who wonders within a building or a site, absorbing and connecting the spaces in apposition, thus obliging us to investigate into cinema's creative force to produce space [15].

Recognizable cities have been very important for the development of cinema as they constitute places for filmic representation and filmic production at the same time [12]. As such, the cinema acquires a double role, being both a "product of urban modernity" and the "producer of urban culture" [16]; Berlin of the 1920s (i.e., Weimar city films), Los Angeles in the 1940s (i.e., Film Noir), Paris of the 1960s (i.e., New Wave), are the cities the viewer wants to live in and inhabit, and the movies of each specific period capture fragments of the alluring modern life.

In the Weimar city films, the fascination with technological advances (e.g., diffusion of electricity, public transportation), the architectural infrastructures, the benefits of urban living, and the emerging urban space, all were the center of attention. The enlightenment of the city gave birth to the city's nightlife and new stereotypes and social trends were born. In other words, the cinematic vision of the modern metropolis focuses on its public spaces [12] and the street is now the center of social encounters. However, as social classes mix, the division of space is rising. On the one hand, the female actresses are mainly underprivileged housewives or 'ladies of the evening'. On the other hand, the male characters are flâneurs and are either criminals or the complete opposite, i.e., law enforcements.

Film noir continues the traditions and adopts the aesthetics of the Weimar city films as many German directors immigrated to the USA at the time due to the war. Notable examples of such films are Fritz Lang's 'Scarlet Street' (1945) and 'The Big Heat' (1953). The division of urban space remains, but the roles of genders change; the woman transforms into a femme fatale, i.e., a mysterious, seductive and dangerous existence, incarnating the city, and the private detective becomes the new flâneur, revealing their secrets, i.e., the woman's and the city's. The alienation of the characters finds its expression throughout the lonesome wandering of the protagonists around the city and the uncanny urban space. Another dipole that develops is that of the urban and the rural landscape, representing seduction and safety and seduction, the promise land and the end of the road.

The French New Wave (or *nouvelle vague*) clearly comprised a juxtaposition to the extant studio system in France, shifting in the 1960s the studio production to an *auterism* movement [12], illustrating the Parisian streets [17]. The *nouvelle vague*, as a film movement, lasted officially for just two years, between 1959 and 1960; yet it had a long-term effect on French and international films to come [12]. The male-female, sexuality-innocence, success-failure, rural-urban dipoles continue to exist and the characters continue to be vulnerable and lonesome, while the underlining story remains that of the lead male character with the city and the woman. An additional common

element is the depiction of urban conditions, an archetype that the cinema has been promoting as the new way of ideal living. In essence, one could argue that the emerging urbanization and the large cities' need for working population used cinema as a lever so as to prepare rural populations towards becoming busy citizens.

1.4. Fear of Technology and Dystopian Approaches of the Nearby Future: the Era of Pessimism

The more we move towards the future and approach today's filmic production, we see that concerns regarding humanity's next days as introduced in 'Metropolis' shift considerably. To begin with, it appears that the images of the future come directly from the past, enhanced with a number of technological additions and/or modifications. For instance, a familiar city can be depicted in an unfamiliar way [18], as for example 'Superman' (1978), 'Blade Runner' (1982), 'Dick Tracy' (1990), 'The Truman Show' (1998), 'The Thirteenth Floor' (1999) to name only a few. In addition, technological advancements have allowed movies' introduction into the virtual world ['The Matrix' (1999), 'Dark City' (1998)]; an environment entirely different from the one viewers were familiar with until that point.

However, a paradox comes into being; technological fears materialize themselves and pose questions with regards to the end of the world as machines and alien species in the big screen threaten humanity [19]. In more detail, such fears further intensify as the representation of future cities rely more and more on the use of advanced technologies. While city representations differ from movie to movie, the common denominator of pessimism regarding humanity's future prevails; as Mennel highlights, only the conditions of "human slavery" change and now the underground workers of Metropolis are trapped "in a virtual prison of their own minds" [12].

Within this context, it is interesting to examine these concepts from an architectural perspective, while adopting the time's viewpoint. Deamer posits that the work of visionary European architects of the '60s (e.g., Archigram, Hans Hollein, Coop Himmelblau, Raimund Abraham), who criticized modernism for getting absorbed by the same bureaucratic system it initially hoped to transform, inspired a new generation of architects [20], who, as put by Hollein, begun debating "whether the building was worthwhile discussing" [21], and thus "[t]he object of architecture became the subject himself²" [20]. She further argues that the 'new man', as envisaged by architects in the 1970s, begun rejecting the machine age, mass production, standardization, repetition and the 'machine aesthetic' as a whole.

1.5. Familiarization with Intelligent Technologies

During the last decades, we have been introduced with the virtual space. Its main characteristic is that it is limitless, while it is very different from what we, as viewers, got used to perceive as real space. Since, as a space, it dissolves and reappears every time one uses it, it is interesting to examine how users approach the new concepts of virtuality and digital space, often coupled with internet-enhanced capabilities, using a movie as our analytical tool.

² The male handle is used because this is how specific architects "referred to themselves and reflects the fact that they were indeed all men" [5].

'Terminator 2: Judgment Day' is an example of the dualism generated between digital and analog, in the beginnings of the digital age. James Cameron, the movie's director, takes advantage of the virtual space, whose fluidity and easy transformations allow him to build the storyline based on this dualism. In the movie, the analog - and familiar - machine joins its forces with the people against the evil - and unknown - digital man, who is sent to Earth by a self-aware artificial intelligence system. The analog machine is heavy cyborg, palpable, and fragile compared to its digital counterpart; its gear moves with a pace similar to that of a human heart. In contrast, the digital, shape-shifting, featureless silver man, who represents evil, is fluid; its pulse is its algorithm which helps it regenerate and whose mathematical structure remains enigmatic [22].

'Terminator 2: Judgment Day' illustrates how viewers, by being familiar with a specific technological image, may change their attitude towards technology in general. In more detail, the audience begins now regarding the analog machine, which they used to be afraid of, as their friend and with whom they join forces in order to win a war against the new, unknown digital world. In other words, the filmmaker succeeds in using viewers' familiarization with the machine and their fear to further engage them and build his narrative.

Moving further along into the present, during the 1990s and beyond, the cultural role of the computer changed; from being a mere tool, it became a medium. As the computer became a universal media machine, users interact mainly with data, such as texts, pictures, films, music or even virtual environments, all of which encapsulate bits of culture. Therefore, "we are no longer interfacing to [sic] a computer but to [sic] culture encoded in digital form" [23].

Such interfaces, and one may argue even more advanced, can be seen throughout Steven Spielberg's 'Minority Report' (2002). The director envisaged the world of 2054 and materialized it through cutting-edge technologies, such as automated vehicles, criminal-identifying spiderbots and large retina displays among others. Undoubtedly however, the most influential technology used in this futuristic film is the gesture-controlled panels [24]. Gesture control is certainly not new, with the first projects having been developed in the early 80s [25]. As such, the 'inventions' appearing in 'Minority Report' are not completely new, but rather extensions of extant technologies. Within this context, it should be highlighted that the particular movie illustrates vividly the uses and abuses of scientific and technological knowledge in cinematographic discourse.

Yet, such concepts and representations are present and discernible in many other movies. As a result, the city, urbanity and architecture itself, as cultural foundations, did not remain insensitive to the influence of this cultural and digital new world that has now transformed into an interface. To be more precise, the architectural quest has shifted from being an endeavor in the formalistic expression (quest of form) to a different one, seeking city branding. Modernity's perception that even the habitat is a machine to live in [26] is taken to the extreme with the proliferation of technology, transfiguring ubiquitous computing and connectivity into a ubiquitous sense of habitat.

2. Discussion

Several studies to date have investigated the technological enactments and urban representations as depicted in the cinema, as for example futuristic city landscapes and

advanced technologies [e.g., 1; 27], the human self [e.g., 28; 29], or scenes of catastrophe [e.g., 30]. However, little has been said about the way the cinema has managed to familiarize viewers with technological advancements and transform them into actors and users of advanced information systems.

As shown from our retrospective into cinematic imaginary worlds, these have now become conventional and are being used in a rather automated manner. Schweinitz posits that this was made possible partly through the use of coherent representations, regularity and repetition, which, on the one hand made reception easier, while on the other hand, familiarized viewers with these worlds. Indeed, the audience is warned by music when danger approaches, recognizes Paris from partial views of picturesque cafés, unconsciously knows that it is difficult to hail a taxi in New York. Gradually, the stereotypes presented in popular films, and generally in all other genres, have become cultural signs [4].

We see that, getting familiar with the big screen and what it broadcasts may result in one getting familiar with technology and smaller, smart screens. Ultimately, this suggests that the spectator may transform into the user of intelligent screens and environments, thus controlling the action.

As suggested by Manovich [23], today, some hundred years after cinema's birth, cinematic ways of viewing the world, telling a story and linking experiences to each other, are being augmented and have become avenues for users to gain access into and interact with cultural data. Our society - self-defined as technologically advanced - has been significantly transformed during the past years thanks to smart information systems and intelligent technologies. City users themselves become more and more familiar with touch-focused interfaces, interactive screens and rich media, thus their role within the urban space, toward the built environment and the society at large changes as well, and shift from mere viewers-perceivers to actors. One could argue that users became intelligent within and through the intelligent systems they themselves created and as they became more and more involved with the production of technology and media.

At the same time technology evolved, and so did the films and humanity. The screen of cinematography in the beginnings of the medium scared its first viewers, but as the familiarization process begun and while even interactive screens permeated our lives, people managed to adopt the new imageries and technologies and evolve with them.

As a result, a new generation of users emerged; intelligent users, who perceive urban context and reality very differently from previous generations. City users live in a mixed reality, a reality found in between the real world and that reflected on the various screens populating urban environments. Regardless if this screen is a photograph, an animated screen or the interactive screen of a mobile device, it transmits a sign that seeks to be interpreted so that the user receives its message, and which may be local-dependent or independent. We thus posit that, this mixed space of real and virtual information, within which intelligent users navigate themselves, has transformed the way people perceive architecture and space in general.

All the while, this new intelligent user is connected to the urban environment. As such, (s)he finds her/himself living in a transformed urban environment, the intelligent city, as the two transform each other through technology. Smart screens, smartphones, and interactive technologies among others, enjoy a ubiquitous presence and as they navigate users within traditional urban environments, reveal multiple realities hidden within them. For example, as the user views a landscape through the

smartphone's camera, (s)he can read superimposed information on the device's screen. Such mixed realities create new ways of perceiving the city and, as in the case of the Situationist's Naked City [31], new maps for the traditional city begin to emerge. The city is interpreted on the screens through the help of arrows, pointing to destinations, addresses, restaurants or social events. Users' everyday paths are documented in smart devices, whose miniaturization begun years decades ago [32], while people consult more often the screens that accompany them than the city's analog signs. Furthermore, even city signs have been digitally enhanced (e.g., QR codes, barcodes) and can now be read through the camera of a smart device [33].

It is in such cases that the user doesn't found her/himself solely within the city's reality, nor within that of the smart device's, but (s)he is in between both. This new reality, known as augmented reality [34], offers different spatial experiences to users.

3. Conclusions

Adopting Baudrillard's viewpoint, "[w]e are all, from a global and interactive point of view, actors in [a] total world event" [35], in which the users can create and interact through their avatars within a virtual world. The proliferation of online social networks, hybrid realities and virtual spaces, among others, have accelerated the transformation of users' perceptions regarding their real and virtual social presence, as they can create, manipulate and share their digital personas online in a similar fashion to offline. Therefore, such technologically enabled realities have altered the way we, today, perceive image, self and space. While the screen is still the medium, it is so solely in an indirect manner, constituting merely the interface of our interactions.

Revisiting once more Baudrillard's writings, it is interesting to pay particular attention in his viewpoint that "[t]he immense majority of present day photographic, cinematic, and television images are thought to bear witness to the world...we have spontaneous confidence in their realism" [3]. He further argues that modern masses' behavior is characterized by conformity, as people tend to comply with the paradigms offered – in our case through the big screen - and while they reflect "the objectives imposed on them", they eventually manage to absorb them. Most importantly however, Baudrillard explores the way cinema manages to advertise not only e.g., products, but a way of life in general [3].

In the past, the big screen was the medium transmitting the action to the viewer, while the latter used to be the receiver. Yet, the medium has now shifted. Today, the viewer controls the action, by both transmitting and receiving information, thus becoming the medium her/himself and transforming into an intelligent user. At the same time, the city, as envisaged in the big screen and, consequently, the city people imagined living in, has transformed into the intelligent city of today.

References

- [1] L.M. Krauss, *The Physics of Star Trek*, Flamingo, Harper Collings Publishers, Great Britain, 1997.
- [2] J.N. Schmidt, Narration in Film, in: *The Living Handbook of Narratology*, P. Hühn, J. Pier, W. Schmid, and J. Schönert, eds., Hamburg University Press, Hamburg, 2009, pp. 212-227.
- [3] J. Baudrillard, *The Evil Demon of Images*, Power Institute of Fine Arts, Sydney, 1987.
- [4] J. Schweinitz, *Film and stereotype: A challenge for cinema and theory*, Columbia University Press, 2011.

- [5] J. Andersen, The Body of the Machine: Computer Interfaces in American Popular Cinema since 1982, *Projections* **5** (2011), 75-95.
- [6] L. Lumiègre, The Lumiègre Cinematograph, *Journal of the Society of Motion Picture Engineers* **27** (1936), 640-647.
- [7] M. Loiperdinger, Lumiere's Arrival of the Train: Cinema's Founding Myth, *The Moving Image* **4** (2004), 89-113.
- [8] V. Lebeau, *Psychoanalysis and cinema: the play of shadows*, Wallflower Press/Columbia UP, London, 2001.
- [9] E. Toulet, *Birth of the Motion Picture*, Harry N. Abrams, New York, 1995.
- [10] A. Notaro, Futurist Cinematic Visions and Architectural Dreams in the American Modern(ist) Metropolis, *Irish Journal of American Studies* **9** (2000), 161-183.
- [11] S. Kracauer, *From Caligari to Hitler: A Psychological History of the German Film* Princeton University Press, Princeton, Oxford, 2004.
- [12] B. Mennel, *Cities and Cinema*, Routledge, London, New York, 2008.
- [13] C. Frayling, *Mad, Bad and Dangerous? The Scientist and the Cinema*, Reaktion Books, London, 2005.
- [14] S.M. Eisenstein, Montage and Architecture (with an introduction by Yve-Alain Bois, translated by Michael Glenny), *Assemblage* **10** (1937, 1989), 110-131.
- [15] G. Bruno, Motion and Emotion: Film and the Urban Fabric in: *Cities in Transition: The Moving Image and the Modern Metropolis*, A. Webber and E. Wilson, eds., Wallflower Press, 2008, pp. 14-28.
- [16] H. Weihsmann, The City in Twilight: Charting the Genre of the 'City Film' 1900-1930, in: *Cinema & Architecture: Méliès, Mallet-Stevens, Multimedia*, F. Penz and M. Thomas, eds., British Film Institute, London, 1997, pp. 8-27.
- [17] S.D. Chrostowska, Vis-à-vis the glaneuse, *Angelaki: Journal of the Theoretical Humanities* **12** (2007), 119-133.
- [18] Y. Chevrier, "Blade Runner"; Or, the Sociology of Anticipation, *Science Fiction Studies* **11** (1984), 50-60.
- [19] A. Milner, Darker Cities: Urban Dystopia and Science Fiction Cinema, *International Journal of Cultural Studies* **7** (2004), 259-279.
- [20] P. Deamer, The Everyday and The Utopian, in: *Architecture of the Everyday*, S. Harris and D. Berke, eds., Princeton Architectural Press, New York, 1997, pp. 195-216.
- [21] H. Hollein, A Comment from Hans Hollein, in: *Archigram*, P. Cook, ed., Princeton Architectural Press, New York, 1999.
- [22] P. Mantziou and D. Polihronopoulos, TERMINATOR II: Final Judgment, in: *Architects*, SADAS-PEA, 2006, pp. 75-77.
- [23] L. Manovich, *The Language of new media*, MIT Press, MA, USA, 2001.
- [24] C. Brown, How 'Minority Report' Trapped Us In A World Of Bad Interfaces, in: *The Awl*, The Awl, 2013.
- [25] R. Watson, A Survey of Gesture Recognition Techniques in, Department of Computer Science, Trinity College, 1993.
- [26] Le_Corbusier, *Toward a New Architecture* Getty Research Institute, Los Angeles, 2007.
- [27] A.J. Huebner, Lost in Space: Technology and Turbulence in Futuristic Cinema of the 1950s, *Film & History* **40** (2010), 6-26.
- [28] S. Holland, Descartes Goes to Hollywood: Mind, Body and Gender in contemporary Cyborg Cinema, in: *Cyberspace, Cyberbodies, Cyberpunk: Cultures of Technological Embodiment*, M. Featherstone and R. Burrows, eds., Sage Publications, London, 1996.
- [29] B.L. Ott and E. Aoki, Counter-Imagination as Interpretive Practice: Futuristic Fantasy and The Fifth Element, *Women's Studies in Communication* **27** (2004), 149-176.
- [30] S. Keane, *Disaster Movies: The Cinema of Catastrophe*, Wallflower, London, 2001.
- [31] S. Sadler, *The Situationist City*, The MIT Press, 1999.
- [32] M. Weiser, The computer for the 21st century, *Scientific American. Special Issue on Communications, Computers and Networks* **265** (1991), 94-104.
- [33] Q. Chen, Y. Du, R. Lin, and Y. Tian, Fast QR Code Image Process and Detection, in: *Internet of Things*, Y. Wang and X. Zhang, eds., Springer Berlin Heidelberg, 2012, pp. 305-312.
- [34] R. Azuma, Y. Baillet, R. Behringer, S. Feiner, S. Julier, and B. MacIntyre, Recent advances in augmented reality, *IEEE Computer Graphics and Applications* **21** (2001), 34-47.
- [35] J. Baudrillard, *The Intelligence of Evil or the Lucidity Pact*, Bloomsbury Academic, 2005.

Neo-Nomad: the man of the networks revolution era

Melina PHILIPPOU¹
Architect Engineer

Abstract. The purpose of this paper is to present the nascent man of the networks revolution within the framework of increasing mobility through analytical and synthetic tools firstly, by defining the impact of mobility in physical space, digital space and the identity and secondly, through the taxonomy of the emerging communities of the neo-nomads.

Keywords. Mobility, neo-nomad, digital nomad, cyborg, connectivity, de-localization, networks

Introduction

The objective of this paper is to study the nascent man of the networks revolution. It aims to present the social unit, born within the frame of “connectivity as the defining characteristic of the 21st century urban condition” [18] resulting from the increasing mobility to all fields. It is this man to whom Marshall McLuhan first referred, as the contemporary nomad-the information gatherer², and Mitchell defined as the digital nomad³. The neo-nomadic figure of our time is going to be analyzed according to its origins, needs and practices of everyday life.

In order to prioritize the neo-nomad’s multiple properties we are going to follow a double categorization procedure both analytical and synthetic. The analytical procedure includes the division of mobility to its constituent fields of digital, physical and mental mobility⁴. Through that, the revolution of networks framework and the neo-nomads configuration forces are going to be presented in detail.

The synthetic procedure involves the categorization of emerging neo-nomadic communities by defining their relation to the mobility components, firstly according to the criterion of work and secondly to the criterion of political action. Concurrently their everyday life patterns, problems and perspectives are going to be analyzed in order to be used as a tool toward the better understanding of architecture’s current user.

¹ Corresponding author: melinaphilippou@hotmail.com

² “The food-gatherer reappears incongruously as information-gatherer. In this role, electronic man is no less a nomad than his Paleolithic ancestors” (M. McLuhan, *Understanding Media: The Extensions of Man*, 1st edition, Canada, Sphere Books, 1964).

³ For a complete analysis up on this matter see W. J. Mitchell, *Me ++ The cyborg self and the networked city*, Cambridge-Massachusetts, MIT press, 2004.

⁴ As suggested by Yasmin Abbas to her lecture neo-nomadism, <http://videos.liftconference.com/video/1169165/yasmine-abbas-neo-nomadism>, Geneve, lift conference, 2011

1. Fields of mobility

In the following section the constituent fields of mobility are going to be presented in connection with wirelessness, hyper-miniaturization, digitation and de-materialization, and in relation to their impact on man.

Digital and physical mobility, as extensions of the senses and the central nervous system, are going to be presented based on *Me++: The city of bits and the cyborg self*, 2004, William Mitchell [18]. Mental mobility as a fluid structure is going to be presented mainly through, *Digital Technologies of the Self* 2009, co-edited by Yasmin Abbas and Fred Dervin [3].

1.1. Digital mobility

Digital nomadism describes actions taking place on-line by individuals and their alter-egos. “It is the navigation in digital platforms and spaces.” [18].

This kind of mobility results from the instant transmission of information and the extension of our nervous systems from a fixed physical space. Digital mobility is a result of the Internet’s growth in global scale within the new rules it implies: Asynchronous communication and de-localization of functions.

1.1.1. Extension of the nervous system

“We have extended our nervous systems to wherever there are sensors with network connections.” [17]

The actions of individuals through networks can extend to different ranges, from millimeters to thousand of kilometers. If the industrial revolution brought evolution to transportation resulting to the extension of the human body in space, the technological revolution led to the extension of the nervous system.

Marshall McLuhan was the first who referred to media as extensions of the human body to his homonymous book “*Understanding media: the extension of man*”. He considered media as extensions of the senses and extensions of information processing on the central nervous system. In addition he predicted the extension of consciousness as the final stage.

“Rapidly, we approach the final phase of the extensions of man—the technological simulation of consciousness, when the creative process of knowing will be collectively and corporately extended to the whole of human society.” [17]

The extension of the senses refers to the extension of our perceptual ability, especially hearing and sight, by means like radio and television, and others provided by the internet like Skype.

The extension of our nervous system was achieved through material and immaterial tools increasing our cognitive skills (e.g. electronic devices, data processing software, scripting languages), as well as memory extension tools which code, store and retrieve memory anytime (e.g. usb, hard disks, drop box). Human experience is now stored in Giga, stories in word, images in jpeg, sounds in mp3, procedures in exe.

Even our consciousness is extended. Unlike media such as radio and television in which the division between transmitters and receivers is evident, the internet provides the potential to be a transmitter, receiver, or both. Interactive communication media in contrast to one-way communication media give the opportunity to present and negotiate a subject in a much larger range than that of the adjoining environment. The

above according to McLuhan gives no excuse to the detachment towards social processes anymore.

“Western man acquired from the technology of literacy the power to act without reacting... But our detachment was a posture of noninvolvement. In the electric age, when our central nervous system is technologically extended to involve us in the whole of mankind and to incorporate the whole of mankind in us, we necessarily participate, in depth, in the consequences of our every action. It is no longer possible to adopt the aloof and dissociated role of the literate Westerner.” [17]

1.1.2. Communication in the age of digital mobility

Digital space has a great impact on the way we interact. It provides the possibility to interact while being at different spaces and at different times. Simultaneity, a sufficient condition for the realization of human practices, during the past, is not valid anymore. In digital space simultaneity is NOT dependent on vicinity [7].

As a result communication has become delocalized and asynchronous. With basic devices we can pay bills anytime without going to the bank, we can organize a demonstration, and we have the ability to communicate with people living in another continent directly (e.g. Skype), or with phase difference (e.g. mail).

The above has extended to the way we do things in everyday life, and as we are going to see below has changed the way we use physical space.

1.2. Physical Mobility

Increasing physical mobility today is not so much a result of the evolution in transportation, as it is a result of “free location practice”⁵ due to the delocalization of functions and the emergence of context aware systems.

1.2.1. Fields of presence

Access to services, documents, systems, communication devices and the internet have become disengaged from space. Man is no more bound to relations of vicinity and has become more flexible.

Mitchell attributes the phenomenon of delocalization, to the transition of the location of resources, from points of presence to fields of presence [18]. For a better understanding he gives the example of water supply through time.

During the formation of the first communities, access to water was possible usually from one point, the well. Anyone in need for water had to visit that specific geographical spot to satisfy it. Through the evolution of mechanics the point of presence was replaced by the water network, a dense grid of infrastructure. There was no need to move in order to find water any more. Each house, public building or private business constitutes a node in the water network. However, when someone has difficulties in reaching the nodes of water infrastructure or is constantly on the move, he can carry a bottle of water. In this case the field of presence is possible through the portability of the resource. In conclusion network infrastructure and portability are the means which ensure fields of presence.

⁵ The ability according to Yasmin Abbas to be independent from space, due to de-localization and dematerialization of functions, Neo-nomadism, <http://videos.liftconference.com/video/1169165/yasmine-abbas-neo-nomadism>, Geneva, lift conference, 2011

The resource, which we are most interested in, is information because it provides the possibility of free location practice. It is a result of hyper-connected wireless networks from the range of millimeters to the range of kilometers and the miniaturization of devices to the level of being extensions and part of the human body.

1.2.2. Context aware systems

Furthermore, the emergence of context aware systems, assist mobility by increasing the awareness about the users current location.

Context aware computing refers to ambient intelligence technological devices which *“exploit emerging technologies to infer the current activity state of the user and the characteristics of their environment. These applications can intelligently manage both the information content and the means of information distribution.”* [8]

Some of their applications concern logical location recognition, location search and recommendation and lastly traffic prediction.

1.3. Mental Mobility

Mental mobility is affected both by digital and by physical mobility. The impact of digital mobility to identity mainly concerns the division of one’s self to multiple identities whereas the influence of physical mobility concerns the configuration of identity through the procedure of negotiation and choice.

1.3.1. Mental mobility resulting from digital mobility

Sherry Turkle since 1995 in *“Life on the Screen Identity in the Age of the Internet”*, quoted, *“digital technologies represent objects-to-think-with for thinking about postmodern selves”* [23] or as set by Zygmunt Bauman digital technologies are objects with which we can explore and discover our multiple identities [6].

The Internet in its creative turn through personal and collective media gives the opportunity to publicly present aspects of identity. These means of presentation and eventually configuration of one’s self enrich everyday life and give a person the opportunity to be appreciated beyond the range of ambient environment.

Everyone has the opportunity to express themselves to a large audience as writers (blog), curators (Scoop it, Pinterest, Tumblr), directors (YouTube –Vimeo) and image-makers (Facebook, Twitter, forums) or collect influential information as a readers, listeners, viewers, friends and followers.

Internet emerges as the utopia where change is possible without a pause .In communication with unlimited contacts the person has the ability to help others construct new identities as well as be influenced to change his self.

This and other perspectives about the issue of contemporary identity are going to be presented below.

1.3.1.1. Nodular subjectivity - Peer to peer identity

Identity nowadays, tends to disconnect from the context of the physical community we leave in and increasingly depend on the delocalized communities we decide to digitally participate. Mark C. Taylor refers to this phenomenon:

“In emerging network culture, subjectivity is nodular, I am plugged into other objects and subjects in such a way that I become myself in and through them, even as they become themselves in and through me.” [22]

The individual is inseparable from the ever-expanding networks it is a part of. The sum of the networks is going to define an important part of the individual's perception, like ways of learning and acting, as well as the individual through its avatar is going to influence the rest of the network's nodes.

"I construct and I'm constructed, in a mutually recursive process that continually engages my fluid, permeable boundaries and my endlessly ramifying networks. I am a spatially extended cyborg." [18]

A few years later, Yasmin Abbas in her essay "Mobilization: an investigation of Barack Obama's Presidential Campaign and Peer-to-peer Identity" [16], refers to the analog of peer to peer procedures⁶, in order to describe the mutual identity formation via digital networks.

Using the paradigm of Barack Obama's first presidential campaign, Abbas argues that distributed networks through the supporters and their skills led to the co-creation of the candidate's identity as well as the identity of each other.

The supporters participation on the procedure, mentally, physically and digitally motivated them to the level of exceeding the boundaries of their everyday life. At the same time the contribution of each supporter to a common cause using different ways of expression became a tool to achieve visibility and strengthen one's own identity. *"Mobilization today is identity-sharing or about peer to peer identity."* [2]

1.3.1.2. Avatar

An avatar is the representation of one's self in videogames and virtual worlds. The properties of an avatar are restrained by the rules of the game and influenced by the culture, habits and knowledge of the individual. The avatar can be pre-defined as in video games with famous characters, or can have larger freedom to its formation as in second life, or in social media. In the second case the subject can accentuate specific characteristics of the avatar, visualize inner desires or construct a completely fictional hero.

As Turkle points out, the Internet *"provides ample room for individuals to express unexplored parts of themselves"*. [23] In this way it operates as a medium for a better understanding of one's self.

The number of avatars corresponds to the number of networks someone is a part of. The subject can move from one identity to another as it moves from network to network or from digital to physical space. In conclusion, identity is a liquid, continuously altered formation of which we can only take snapshots.

1.3.1.3. Digital reality

According to Olivier Maucó *"Ideology is produced not only by words, but also by acts performed within a predetermined framework"*. [16]

From this point of view digital realities and video games can be seen as systems in which the player is invited to act within a predetermined framework. The avatar of the subject exists and is defined not through being (as in physical space) but through the decision for actions taking place to the specific digital space. As it can be concluded from the above, digital realities and video games are ludic ideological systems, forming the player's identity and because of that can be considered as *"machines producing subjectivity"* [12].

⁶ P2P procedures use distributed networks. Participants interact contributing according to their skills in order to create common value (e.g. open source software).

1.3.1.4. *The data collector:*

The collector gathers objects of his interest. Through them the past continues to merely exist via recollection.

The collector of the digital era through social media and other communication platforms is a collector of people. Additionally through platforms like Pinterest, Scoop it and Tumblr the collector can gather and categorize his digital collection of objects. Furthermore, collecting is nowadays facilitated by increasing capacity of storage devices.

The memorabilia of a lifetime, people, images, video, can all be stored in a small portable device the size of a palm. According to Leopoldina Fortunati in her essay “The mobile phone: Towards new categories and social relations” [10], the possibility of retrieving all this information has the powerful effect to reduce uncertainty from the neo-nomad’s liquid way of living⁷. The fragmented self of digital and physical mobility can recompose by having the possibility to access at any moment to the sum of its own communicative network and collection of the past employing portable devices. The collector holds his identity in his own hands and it has the form of data.

1.3.2. *Mental mobility resulting from physical mobility*

Crossing borders can sometimes mean to pass through different ethics and social status. It might be necessary to readjust every time in order to survive in different cultural environments. As a result the neo-nomad has developed adaptation techniques.

On one hand, the nomad wants to adapt to the new environment on the other hand he needs to sustain his own identity of transition and flow. As a result there is a part of him that resists temporary adaptation. According to Yasmin Abbas [1], he maps the new territory in order to understand it, and then negotiates and chooses which of the territory’s characteristics he is going to embody.

Identity becomes an eclectic structure made of cultural fragments chosen through the procedure of negotiation and choice.

1.4. *Conclusions*

Through the description of the three components of mobility we come to the conclusion that neo-nomadism concerns mainly the influence of digital mobility -as an outcome of the networks revolution- to physical and mental mobility. Free location practice and the emergence of ambient intelligence were necessary conditions towards increasing physical mobility, whereas the new conditions in digital and physical mobility influenced the formation of contemporary liquid identity.

2. **Nomads taxonomy**

The three components of mobility are going to be placed to a three axis system (Fig. 1), in order to create a tool for defining the emerging neo-nomadic communities.

⁷ “This modal personality strengthened by the mobile phone is a personality that manages to reduce uncertainty. (...) It is the possibility of contacting its own communicative network at any moment that has the powerful effect of reducing the uncertainty that mobility brings with it.” (L. Fortunati, *The mobile phone: Towards new categories and social relations*, *Information, Communication & Society* 5 (2002), 513-528.)

The first criterion of categorization is work. Immaterial labor and the delocalization of work created the framework for a generation of workers directly correlated to the level of physical mobility. The transition from material to immaterial labor is going to be presented through Petros Linardos Rilmon [19] and Paul Saffo [21] writings, whereas the evolution of technology which led to the delocalization of work through William J. Mitchell's, *Me++: the cyborg self and the networked city*, [18]. Finally, the problems and practices of urban and global nomad's everyday life are going to be presented in order to achieve a better understanding of their needs.

The second criterion of categorization in order to define the emerging nomadic communities is the way to exploit digital mobility in order to serve different strategies. In the beginning of the World Wide Web, according to Bauman [5], the group in charge of the information flow was the global elite. However the recent example of the Arab spring as described by Gastón R. Gordillo [11] and reinforced by the theory of Deleuze and Guattari [9] proves that the internet can compose the smooth space of nomads and turn against the State's machine.

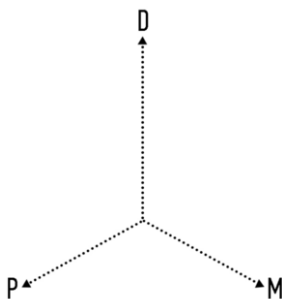

Figure 1. The 3 axis of mobility system for the taxonomy of nomads.

2.1. Dematerialization of work

Industrial revolution was a promise for abundance through increased production. Mechanical evolution aimed to satisfy the material needs of the working class and the emerging middle class.

Productive economy is based on the factory as the basic production unit, and the division between material and immaterial labor. The worker is expected to enthusiastically participate in specialized production line work, through the development of the ideological construct of work ethics.

Work ethics dictate that a man is useful only when he contributes to progress, and progress is possible by contributing to the industrial revolution as a specialized worker. From this point of view unemployment is seen as a denial to evolution [5].

However, not long afterwards the problem of increased production shifted to the problem of increased demand, from production to sales and marketing. Mass media are the basic tool of this era. Informational and cultural context of products become the main activity of labor. Informative content concerns increasingly computing applications while the cultural content concerns the kind of activities including the definition and determination of cultural and artistic rules like taste and consumer patterns. According to Petros Linardos Rilmon the activities above, used to employ an elite, but since the 70's converted to the field of mass intellectuality [11].

The worker of our era is the mental- immaterial worker and has moved from the factory to the iconic office buildings. Not for much though...

2.1.1. De-localization of work

At the beginning of 2000 the wide spread use of wireless networks and mobile devices made access to information and people possible, wherever connectivity existed. Simultaneously the compression of storage, the transformation of information products (e.g. texts, images) to reproducible data without loss of cost or quality and the possibility to employ computer intelligence to manage complex flow and delivery processes automatically, have delocalized work.

A worker equipped with basic infrastructure can be productive at home, on vacation, on the train, on the waiting room. Any place is a possible office. *“Electronically engaged, ad hoc meeting places dominate fixed locations and inflexible schedules that had once been necessary to enable interaction and coordination”* [18].

The emerging work pattern of the 21st century is that of the mobile-worker who appropriates multiple environments as work spaces. The immaterial worker of the 21st century is neither closed into a monastery library where knowledge was kept at the 14th century, nor closed in an office cubicle connected to a p.c. He is a hybrid, a cyborg moving wherever connectivity is possible.

2.1.2. Problems and emerging practices of the mobile –workers

When it comes to the range of mobility in physical space, there are two kinds of mobile workers, the Urban -nomads and the Global-nomads.

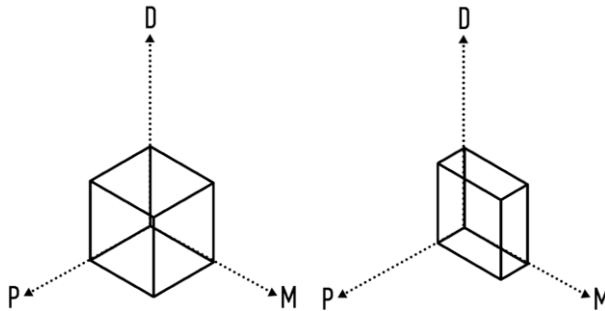

Figure 2. The Urban-nomad and the Global-nomad.

Urban nomads can be free-lancers in the creative field or field of services being able to have a flexible schedule, change work environments, work for a client in distance (Fig. 2). Global nomads travel big distances in order to work. They can be scientists with presence to several institutions, workers at global institutions like the UN and NGO's, or free lancers as described above. Urban and Global nomads share common characteristics and practices in everyday life, however to a different level dependent on their range of mobility. These shared characteristics are going to be presented below.

2.1.2.1. *Neo-minimalism*

Like the Bedouin carries only the necessary supplies in the desert because he knows where the oasis is located in his route, the mobile worker travels light having awareness about what he can find to his ambient space.

Fleura Bardhi (Northeastern University), Giana M. Eckhardt (Suffolk University), and Eric J. Arnould (Bath University) in their study about the consuming patterns of mobile workers at 2012, came up with some interesting conclusions:

Neo nomads tend to have situational attachments to objects and appreciate objects firstly for their function, especially those ensuring connectivity. Furthermore, products for them are disposable and they have no emotionality attached to them [4].

The above explains the emerging trend of neo-minimalism, the rejection of all unnecessary products in order to facilitate nomadic life.

Writer, Sean Bonner in his web page "*neo-minimalism and the rise of the techno-nomad*" [14; 15] highlights ownership as stressful while travelling, whereas writer and designer Graham Hill in his lecture "*Less things more happiness*" [13] suggests ways to facilitate everyday life by disposing unnecessary objects and by using smaller and multifunctional objects and spaces.

2.1.2.2. *Co-working*

The facilitation of work through network platforms and joint professional space is rapidly increasing.

In digital space the online communication and data exchange platforms enhance cooperation with a large professional network, while promotion platforms facilitate new collaborations.

In physical space, co-working gains ground. Even when it is possible to work wherever there is infrastructure for connectivity, the need for company, the value of exchanging opinion and tips with other professionals, and the need to separate work hours from leisure were probably the reasons leading to it.

Urban and global nomads can nowadays temporarily rent workspace for which they share expenses for consumables and infrastructure [20]. In this case physical space functions as an office for multiple and from different fields, passengers. The fixed vessel of function receives the continuing flow of users. Given how space consuming the exclusive use of a space would be for a nomad, considering his ephemeral stay in each stop, the idea of shared use of spaces gets increasingly popular.

2.1.2.3. *The fusion of work and leisure*

In the beginning of de-territorialization of work, flexibility in the schedule and location was accepted as freedom. However collaboration with people living in different time zones, the possibility to be reached 24/7 through different media and lastly the personal tyranny of productivity created ambiguity between working hours and personal time.

In a more optimistic point of view Marshal McLuhan connected the abolition of division between work and leisure to the return to a primitive way of living, where the whole man is involved with his work in order to satisfy the needs of his tribe.⁸

⁸ "Work however, does not exist in a non-literate world. The primitive hunter or fisherman did no work, any more than does the poet, painter, or thinker of today... Work begins with the division of labor and the specialization of functions and tasks in sedentary, agricultural communities. In the computer age we are once more totally involved in our roles. In the electric age the "job of work" yields to dedication and commitment, as in the tribe." (M. McLuhan, *Understanding Media: The Extensions of Man*, 1st edition, Canada, Sphere Books, 1964).

Partly McLuhan's vision has come true through Peer to Peer production communities (P2P). P2P uses distributed networks. The participants are volunteers who contribute according to their skills and needs towards the creation of a common e.g. software. The commitment to a procedure in which work and leisure are combined in order to create a useful product for the whole community has similarities to McLuhan's perspective up on work in the computer age. However peer to peer production does not provide income to its participants so until today it is a part time activity.

2.2. *The emerging neo-nomadic communities according to the categorization criterion of political thought*

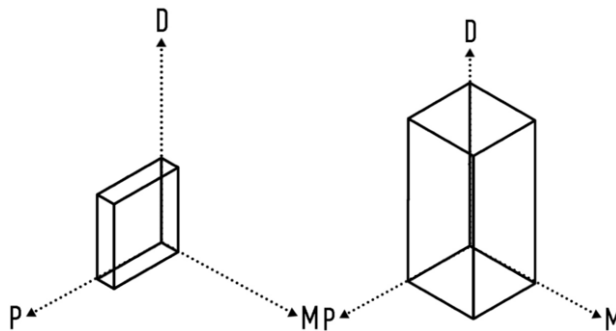

Figure 3. The Global-elite and the Digital-activist.

2.2.1. *The global- elite and Castells space of flows*

During the 80', mobile workers were perceived as a privileged de-territorialized elite. Jacques Attali in "*L'homme nomad*", named them hyper nomads.

According to Manuels Castells they are the people representing the space of flows. "*The network of places that are connected around one common simultaneous social practice via electronic circuits and their ancillary systems*" [7].

Until the beginning of the 90' the space of flows was connected to the dominant financial activities [the financial business centers and their communication network via internet] and consequently the space of the elites managing them.

According to Zygmunt Bauman, the Global elite contemporary sovereignty is similar to the old-style pattern of absentee landlords⁹ meaning it concerns control over a space, without any social and cultural involvement.

Mobility is connected with the multinational company yuppie, the frequent flyer with his cell-phone that lands at different locations always connected to networks but never connecting to space (Fig. 3).

2.2.2. *Digital activists and Deleuze & Guattari smooth space*

The connection of contemporary nomadism to the global elite ceased during the late 90' when the World Wide Web spread widely and the vision of a human centric computer

⁹ Absentee landlord is an economic term for a person who owns and rents out a profit-earning property, but does not live within the property's local economic region. This practice is problematic for that region because absentee landlords drain local wealth into their home country, particularly that of rural areas and the Third World. The term "absentee ownership" was popularized by economist Thorstein Veblen's book of the same name, *Absentee ownership* (http://en.wikipedia.org/wiki/Absentee_landlord)

interaction design emerged via the development of ambient intelligence. As a result of the above the space of flows was not restricted any more to the dominant financial activities and opened up to actions concerning communication and every day human experience. Furthermore, the space of flows as a materially based system consisted of devices we mostly have access to, can be exploited by different groups of people for their own strategies.¹⁰

An affirmation of the above is the recent example of Arab spring. In this case Castells space of flows, once considered the space of an elite of workers is muted to the smooth space of Deleuze and Guattari nomads [9] (Fig. 3).

The internet simulates Deleuze and Guattari smooth space. It distributes to its infinite and ambiguous space without boundaries and enclosures. It is fluid and non-hierarchical. It resembles more a continuing procedure of being, rather than the formation of a whole. Additionally, navigating through the internet resembles the nomadic thought which uses continuing relocations and associations. However the most important of all is that the internet has the largest speed of transmitting a message, the basic constituent of the war machine against the state machine.

The speed of social media gave the opportunity to Tunis, Libya, Bahrain, Yemen and Oman to stand up to the sovereignty of the state machine and raise the awareness about their problems to the globe. On the other hand the state machine exercises its forces in order to striate-territorialize the nomadic smooth space. According to Gastón R. Gordillo [11], the Mubarak regime attempted to re-territorialize smooth space first, by controlling the flow of information through the famous “internet switch” to key buildings of Cairo (e.g. Telecom) and afterwards by hunting online activists to physical space and imposing them to the laws of the striated space (boundaries and enclosures).

3. Epilogue

The neo-nomad is the promising man of the 21st century. Through digital technologies, he has extended his senses, nervous system and consciousness in a way he can be actively involved to the whole mankind abolishing the detachment of the old one-way media. Due to miniaturization and hyper-extended wireless networks, he has the ability to enjoy free location practice and under the influence of local and global networks, he is continually configuring his personal identity.

His problems and everyday life practices emerge within the frame of the cross-linkage of physical and digital space. His main problem is the fusion of work and leisure at the expense of free time, a side effect of de-localization and dematerialization of work. An optimistic point of view about the above can be found to Marshall McLuhan's writings and through the paradigm of P2P production. It is the emergence of a socio-economic model resembling the organization of primitive communities where the whole man is involved to the procedures contributing to the prosperity of a community.

According to the taxonomy based on the criterion of work, urban and global nomads are heading towards a way of living where consuming and ownership are surpassed by multi-functionality and occasional use. Simultaneously the trend of co-

¹⁰ Since 1999 Castells revoked his writings about the space of flows pertaining only the dominant financial activities, to his paper ‘Grass rooting the Space of flows’ (M. Castells, Grassrooting the space of flows, *Urban Geography* 20 (1999), 294-302.)

working rises, giving the opportunity to meet a network of possible associates. Additionally and important enough, co-working in physical space is an answer to the question of space management in the era of mobility. The fixed vessel of function receives the continuing flow of users.

According to the taxonomy of nomads based on political action we realize that the global-elite that used to control the flow of information during the beginning of the World Wide Web has found an opposing force resembling the Deleuze and Guattari nomad who uses the features of digital mobility in order to open the flow of information to channels that the global –elite kept closed. The man of our time has in the center of his existence mobility and as his basic pursuit connectivity.

References

- [1] Y. Abbas, *Embodiment: Mental and Physical Geographies of the Neo-nomad*, Master of Science in Architecture Studies, 2001.
- [2] Y. Abbas, Mobilization: an investigation of Barack Obama Presidential Campaign and Peer-to-peer Identity, in: *Digital Technologies of the Self*, F. Dervin and Y. Abbas, eds., Cambridge Scholars Publishing, Cambridge, 2009, pp. 85-106.
- [3] Y. Abbas and F. Dervin, eds., *Digital Technologies of the Self*, Cambridge Scholars Publishing, Newcastle, 2009.
- [4] F. Bardhi, G.M. Eckhardt, and E.J. Arnould, Liquid Relationship to Possessions, *Journal of Consumer Research* **39** (2012), 510-529.
- [5] Z. Bauman, *Liquid Modernity* (Trans. Originally published: Polity Press, 2000).
- [6] Z. Bauman, *Identity: Conversations with Benedetto Vecchi* (Trans. Originally published: Polity Press, 2004).
- [7] M. Castells and M. Ince, *Conversations with Manuel Castells* (Trans. Originally published: Polity Press, 2003).
- [8] D.J. Cook, J.C. Augusto, and V.R. Jakkula, Ambient intelligence: Technologies, applications, and opportunities, *Pervasive and Mobile Computing* **5** (2009), 277-298.
- [9] G. Deleuze and F. Guattari, *Nomadology: The war machine* (Trans. B. Massumi, Originally published: Semiotext (e), New York, 1986).
- [10] L. Fortunati, The mobile phone: Towards new categories and social relations, *Information, Communication & Society* **5** (2002), 513-528.
- [11] R. Gordillo, The Speed of Revolutionary Resonance, <http://www.re-public.gr/?p=4362> (2011)
- [12] F. Guattari, *Chaosmosis: An Ethico-Aesthetic Paradigm* (Trans. P. Bains and J. Pefanis, Originally published: Indiana UP, Bloomington and Indianapolis, 1992).
- [13] G. Hill, Less stuff, more happiness, TED, http://www.ted.com/talks/graham_hill_less_stuff_more_happiness.html (2011)
- [14] <http://boingboing.net/2010/09/10/technomads.html>,
- [15] <http://guynameddave.com/2010/11/the-minimal-challenge/>.
- [16] O. Mauco, The ideology of self in ludic digital worlds, in: F. Dervin and Y. Abbas, eds., Cambridge Scholars Publishing, Newcastle, 2009, pp. 109-125.
- [17] M. McLuhan, *Understanding Media: The Extensions of Man* (Trans. Originally published: McGraw-Hill, Canada, 1964).
- [18] W.J. Mitchell, *Me ++ and the networked city* (Trans. Originally published: MIT press, Cambridge, Massachusetts, 2004).
- [19] P.L. Rilmon, Knowledge and work, http://withinthemultitude.blogspot.gr/p/blog-page_4815.html (2010)
- [20] M.S. Rosenwald, Telecommuters cut the cord, *Journal* (2009, July 29), <http://business.time.com/2009/07/29/the-new-work-environment-from-office-drones-to-co-working-with-digital-nomads/-ixzz2J0YICrsj>
- [21] P. Saffo, Get ready for a new economic era, What Matters <http://www.saffo.com/essays/> (2009, February 26)
- [22] M.C. Taylor, *The moment of complexity: Emerging network culture* (Trans. Originally published: University of Chicago press, Chicago, 2002).

- [23] S. Turkle, *Life on the Screen: identity in the age of the internet* (Trans. Originally published: Touchstone, New York, 1997).

Precedents for Critically Designing Interaction with Computational Artifacts and Spaces

Efrosini Avrami and Dimitris Charitos¹

*New Technologies Laboratory in Education, Communication and the Mass Media
Department of Communication and Media Studies, National and Kapodistrian
University of Athens
5 Stadiou str., 105 62 Athens, Greece*

Abstract. In this paper we explore the intersection between technology, design and culture in the context of computational artifacts and intelligent environments. The experience of space is discussed from the perspective of phenomenology and relevant writings of architectural theory. We then outline the role of theoretical and practical knowledge from the area of design studies in emerging technological environments by examining theories and approaches that help designers and researchers shape and support the process of interaction. We examine the role of cultural theories for informing the context within which we design interaction, while exploring the possibilities for enhancing users' engagement. In particular, we investigate critical theory as an approach to interaction design that provokes a reciprocal communication between users and artifacts. By artifacts in this paper we mean everyday objects embedded with computational technology, electronic devices and emerging technologies. To embrace this approach, we examine the relevance of aesthetics in interaction and we take into account emerging design theories such as speculative design for experimenting with computational artifacts and consequently raise awareness on the implications of future networked environments. In a world of pervasive computing, we explore how critical design research can inform the process of designing intelligent objects.

Keywords. Interaction design, critical design, design theory, HCI, speculative design, phenomenology of space, ubiquitous computing

1. Introduction

How do people relate to and interact with intelligent environments and with the computational artifacts situated within them? In the context of the great expansion of the ubiquitous computing and the emergence of large-scale networked and intelligent environments, how is interaction transformed and what kind of theoretical approaches apply to the design process? As the physical world is increasingly integrated with digital content, the way we perceive the large amounts of information changes in response to this technological development. As we find computation more often embedded into everyday objects and the environment we inhabit is increasingly becoming digitally networked, interaction with computation expands into physical

¹ Corresponding Author: Dimitris Charitos, Email: vedesign@otenet.gr

spaces and consequently the need for integrating new approaches into the design of such spaces emerges. The focus of attention is on the interaction with the artifacts integrated with computational technology, by exploring the ways into which this reciprocal relationship moves beyond the task performance to a more meaningful expression and interaction. Norman [27] explores interaction with computational artifacts within our daily context through a series of elements and conceptual models, creating the framework for further investigating the relationship between people and those objects. The role of design practice, as described in this paper, is to produce the framework for exploring our interaction with emerging future technologies through design methods and theories. Critical theories are exploited into the design process in order to create those conceptual scenarios that enable designers and users to participate in a mutual exchange of expressions. The role of Ambiguity [16] in users' interpretation and the relevance of Aesthetics [4] as an essential factor for establishing this interpretation may become new approaches into design. Attention is placed on how interaction can bring new forms of engagement and experience different from those associated with traditional methods of Human Computer Interaction (HCI). In addition, Interaction Criticism [3] as an emerging approach into the design field aims at informing the design process as well as interaction design research.

The challenge for designers and researchers is to place the process of designing intelligent objects and spaces into a cultural context beyond the functional, material and ergonomic aspects of an artifact. At the time of significant technological changes, the ultimate goal is to not just use the computational objects to perform tasks but rather to engage and create meaningful experiences, as derived from interaction into the complex intelligent environments. In this regard, the purpose of design research is to create the context into which interaction is taking place, to consider how users interpret that interaction and consequently to enrich design theory with new cultural approaches.

2. Investigating the spatial experience in intelligent environments

In this section an attempt is made to discuss the spatial experience afforded to users of intelligent environments. This attempt adopts a phenomenological approach, as opposed to the traditional empirical approach, on the understanding that such an approach may be more appropriate when aiming to study the essence of the spatial experience in any environment, physical, virtual or hybrid. Ultimately, the aim of this discussion is to begin to comprehend the nature of the spatial experience in intelligent environments.

Lefebvre [22] and Merleau-Ponty [25] have made a distinction between two conceptions of space, two possible ways in which a subject may relate to space:

- The representational space, which is bound by media - paper, computer - and methods of representation -plan, elevation, perspective, etc.; this is a geometrical, abstract and objective kind of space that a subject may reflect about, in other words think about the relationships that underlie this world, while realising that they live only through the medium of a subject who traces out and sustains them. This type of spatial conception is a medium for objects and an object itself and as such it is an appropriate perspective through which to view the design process of any type of spatial experience.

- The lived space which is not represented - or conceived -but subjectively experienced by each individual user; the concrete space of the user's everyday activities. In this case, the subject does not think - or reflect - about space but lives in it, 'lives among things' and experiences them - and consequently experiences space - in an egocentric manner: "*my body and things, their concrete relationships expressed in such (relative) terms as top and bottom, right and left, near and far may appear to me as an irreducible manifold variety*". [25].

Thiel [33] defines the spatial experience, in the broadest sense, as "*a biological function, necessary for the continual adaptation of any organism to its environment, for the purposes of survival*." Experiencing space does not only involve the perception of visual sensory input but of auditory, olfactory, thermal and tactile input, along with the sense of proprioception - as defined in Gibson [19] - all of which play their part in the establishment of a sense of space.

Norberg-Schulz [26] explains the orientational aspect of the spatial experience: "*Most of man's actions comprise a spatial character, in a sense that objects of orientation are distributed according to spatial relations.Man orients to objects; he adapts physiologically and technologically to physical things...(and) his cognitive or affective orientation to different objects aims at establishing a dynamic equilibrium between him and his environment*." But these objects, which are distributed in space, actually allow for space and the spatial experience as such. Perceptual images are generated by the perceptual systems of the human as a result of phenomena. Piaget [28] defines an object as "*a system of perceptual images endowed with a constant spatial form throughout its sequential displacements and constituting an item which can be isolated in the causal series unfolding in time*". It may be therefore suggested that our world consists of phenomena and the most permanent relations between phenomena constitute an object. We survive in our environment by orienting ourselves to objects, which are being manifested to us through the psychological and cognitive processes involved in the perception of phenomena.

Space is, therefore, defined by objects, or elements of form which bind it. Merleau-Ponty [25] argues that: "*there is no question of a relationship of container to content (between space and the objects that define it), since this relationship exists only between objects, nor even a relationship of logical inclusion.....since space is anterior to its alleged parts, which are always carved out of it. Space is not the setting (real or logical) in which things are arranged, but the means whereby the position of things becomes possible, This means that instead of imagining it as a sort of ether in which all things float,we must think of it as the universal power enabling them to be connected*."

If we project Merleau-Ponty's above mentioned argument to the essence of the spatial experience afforded by an intelligent environment, which comprises physical elements as well as computational artifacts, we could argue that this experience is not only determined by the material properties of those objects but mostly by the complex network of relations amongst the physical and mediated objects that this environment consists of, rather than the setting within which these objects are arranged. We could then suggest that when considering the design of intelligent environments, one has to focus particularly on the connections amongst physical and computational objects and on the way that these may be transformed as a result of interaction with the participant.

These connections as well as their potential to dynamically evolve in time have to be systematically understood and orchestrated accordingly. The above considerations are equally important with the design of each of the physical objects, the computational artifacts, the representations that objects may display and their distribution within the overall spatial arrangement of this environment.

3. Theories that form design practice

Design has changed considerably during the last decades with regard to its purpose and the methods that it incorporates. Today the practice of design is considered primarily as a process [9] and is associated with a series of activities [2] with ultimate goal the provision of a product, infrastructure or service with specific purpose and functionality. In the most common sense the notion of design is associated with the definition of problem-solving and interaction design in many cases is considered as the execution of a series of activities for the accomplishment of a task. In particular, design involves the creation of prototypes, the visual representation of the information, the creation of scenarios as well as the investigation of material, human and ergonomic constraints and is associated with many disciplines such as Architecture, Visual Design, Industrial Design, Computer Science, Psychology, Ergonomics, Interaction Design etc. In many cases the term is associated with artistic expression, or it is related to creative thinking by means of producing innovation. As technology is significantly integrated into our environment in an intelligent manner, the term is blended with cultural [2] and social factors and therefore design is used for creating imaginary products, functionalities and interactions with intelligent objects and spaces. Antonelli [1], asserts that the designer is changing from form giver to fundamental interpreter of an extraordinary dynamic reality, while she outlines the convergence of design practice and computer science.

In the same context, Friedman and Stolterman [9] suggest that a series of challenges in design practice require new approaches for design thinking, while DiSalvo [9] indicates an alternative practice of design, that of producing experimental forms—artifacts, systems, events—to shape beliefs and courses of action. It is essential for researchers and designers to understand this new framework within which the design practice is conducted and to try to acquire the multidisciplinary knowledge which is necessary for them to function effectively in this process from their own perspective.

4. Designing for interaction in technological environments

According to McCullough [24] interaction takes place “Everyware” in the context of computational artifacts and intelligent spaces. In order to investigate and design interaction, Winograd [34] argues that the research focus won’t be in traditional areas of hardware and software but rather he claims, at enhancing our ability to understand, analyze and create interaction spaces. Crang and Graham [7] outline the significant expansion of pervasive technology and the embedding of digital information within our environment, suggesting conceptual approaches for examining the emerging implications and challenges. The implication for designing and evaluating those interaction environments is outlined [29] while social interaction and mediated communication within urban context is explored [8]. Designing systems and

technological infrastructures within these techno-social environments enable people to interact and engage with them. McCullough [24] outlines the value of embodied affordance as the way we perceive the designed objects and we interpret the interaction, suggesting that it is a significant cognitive factor in the build environments.

In addition, many researchers have become interested in exploring the interaction with computational artifacts in domestic environments [5], [14], or for health purposes [15]. The great interest in examining the interaction with technological artifacts in domestic settings is based on the relationship we have developed with the systems and objects we interact on a daily basis, a relationship which is characterized by “Intimacy”.

Due to the great expansion of technology, the role of interactive artifacts has changed considerably during the last decades. By computational artifact, we refer to the designed objects inhabited within our daily life integrated with computational technology. In particular we are talking about physical artifacts since we act in physical space. As technology is shifted from the desktop into the everyday objects, it is no longer sensible or ergonomic to interact with computational artifacts by using a mouse, the keyboard and the screen. Instead we need novel forms of interaction such as tangible [20] and embodied interaction to be able to efficiently use those artifacts. From electronic devices, to everyday objects and technological devices that enhance intimacy [21], any form of infrastructure in the build environment or object that contains digital content should be taken into consideration for the purpose of creating rich engaging experiences. In the case of these objects, information may exceed the limits of the interface and be manifested via interaction with the object as an entity. It is therefore not only the interface in the form of a screen² that matters in the interaction process but rather the object, as a whole, with all its properties.

The intersection of computational artifacts such as electronic devices and machines with practices from cultural theory has created hybrid forms of objects. Those computational artifacts can serve as cultural artifacts that encourage experimentation and increase users’ participation and engagement. In this regard, the form of the computational artifact as well as the notion of affordances [16] should be taken into account in order to provide ways for interpreting the interaction.

5. Towards a critical approach into interaction design research

The notion of ludic design has emerged as a new situation where people experience the devices, inhabiting in their environment in a more meaningful way [15]. Research studies in this field are based on cultural approaches in design methods such as Cultural Probes [17].

In an effort to integrate certain cultural methods and perspectives with the process of design, the notion of Ambiguity, as an essential factor of interaction interpretation, is explored. The relevance of ambiguity in interaction design research gives designers the ability to suggest issues and perspectives for consideration without making clear the functionality of the artifact or without necessarily imposing solutions to the users [16]. In this regard, design can be used as a critical medium which can provoke participation and increase knowledge. Design Fiction [32], Speculative Design [9], [10] as emerging approaches to design, resulting from the intersection of art, culture, design and computer science, may also be understood as using design as a means of political and

² Or projection or any other form of visual or sensory display in general.

social expression. Speculative design projects explore the situation of imaginary products in future environments and prompt questions about the implications of the technological environments where computation is integrated in our daily life. Its purpose is to provoke discussion among the designers, researchers and users and to question any assumptions regarding the interaction process [9]. In many cases, speculative design is used for exploring future-oriented concepts and scenarios of using technology and for understanding the possible effects, consequences as well as constraints of that use [10]. DiSalvo and Lukens [10] explore the use of speculative design in the development of *technological fluency*, illustrating the term as the capability to understand, use and access technology beyond its application.

Finally, Dunne and Raby [12] have coined the term critical design, to describe a design practice that utilizes artifacts in order to prompt questions and raise awareness about cultural issues, to rethink assumptions about the role of products in our lives. In critical design practice, the result is not the production of 'useful' objects or 'usable' interfaces, but rather the creation of artifacts that raise awareness, provoke action and expose assumptions [13].

6. Design theory as a medium for exploring emergent future technologies

As objects and environments are fully integrated with computational technology, it is highly important to prepare the research framework for exploring our relationship with the computational artifacts embedded within the environment we inhabit. Theories from cultural studies into design practices may help designers and researchers in the field to create conceptual scenarios in order to explore the challenges from this new technological area as well as to adapt to the technological and social changes.

Several architectural practices in the past [10] (i.e. Superstudio), have maintained a critical approach while exploring and producing prototypes and scenarios for possible future structures and buildings. Similarly, we need to investigate relevant scenarios in order to acquire the knowledge for building a sustainable relationship between people and computation artifacts. In this regard, we need to create the framework within which we may design the interaction with those systems and environments. The design process will not be driven only by the human needs or the functionality of the artifact but rather it will aim to create an engaging experience, while ultimately maintaining a critical approach towards the sociopolitical impact of the actions of creating and using these artifacts. In addition, designing interaction exceeds the notion of making the artifacts usable and efficient by presenting their functionality in a clear manner to the users [16]. Instead it aims at provoking assumptions regarding the way we may interpret their functionality, increasing our knowledge and raising awareness on the elements that constitute this relationship. This existing knowledge can be retrieved in similar situations and provide solutions to emerging issues [10] [12].

A series of projects related to critical theory and speculative design examine possible scenarios for the emerging future environments, exploring the way people interact with computational artifacts. A notable work in this field is the project Technological Dreams Series: No.1, Robots that Dunne and Raby [11] developed in order to create a conceptual scenario on how the computational artifacts, such as robots will relate to us in the future. In this work, the designers provide insights and identify issues and challenges raised by the technological expansion into our life.

Such cultural approaches into creating visionary concepts and designing user interaction with computational artifacts can inform and provide a framework for further investigation. In particular the intersection of interaction design research with cultural theories can contribute to:

- **Identify future technological challenges and implications:** In response to the large amount of data aggregation and the digitization of the information, what kind of identification mechanisms will be developed for accessing this information? What form will the interaction between people and those mechanisms take? In addition, in which form will data be presented to users? These are some examples of the issues that may be raised due to the abundance of the information. Design research and practices can identify those challenges and set the framework for further investigation.
- **Re-imagine usage and functionality:** Critical design can help us imagine new potential uses for already designed objects with established functionalities. Providing alternative usage for an object which has been designed to support a different function may transform our conception of the object and may also encourage alternative forms of interaction. (i.e. see Fig. 1) Significant research and artistic work has been done in domestic settings [5] [14] exploring new uses beyond the established functionalities for everyday objects, devices and home furniture.
- **Encourage experimentation:** Experimenting with the computational artifacts in the form of re-thinking uses and interpreting alternative functionalities is essential in critical design as it enhances users' engagement as well as fosters participation and expression.
- **Raise awareness and increase our knowledge:** one of the main contributions of cultural theory to interaction design is the fact that it may increase our knowledge about interaction and substantially about the artifact which we interact with. This knowledge can inform our interpretation, can raise awareness on issues and implications of the artifact's use and ultimately can create the context which will help designers and users to adapt to these technological changes.

The interaction design process is associated with the identification of the problem and of the constraints and involves the implementation of a series of tasks for the development of solution(s). Evaluation methods for measuring the efficiency and the task performance are utilized within the design process. Rather than achieving rationalization of the design process, at a time of continuous expansion of digital information, it is essential to approach design research as a cross-disciplinary practice, involving theories from different scientific fields.

Critical design is primarily considered as a design research model the ultimate goal of which is the creation of artifacts that provoke critical judgment instead of usable and functional products. In particular, both designers and users may participate in the process in an attempt to find not a single solution to the problem but rather many possible solutions to this problem. Ambiguity in the users' interpretation enhances experimentation leading to an iterative process where the problem is reformed, and where new concepts and alternative scenarios of usage are created.

Research through design [35] characterizes the process into which designers critically explore the interaction with the computational artifacts in order to increase the required knowledge and make the necessary assumptions for adapting to the technological changes. The artifact in the form of a product, device or prototype is the means for producing concepts of interaction and for addressing issues for further investigation.



Fig.1: View of an installation which was a part of a group exhibition titled «Tone Home», by Coti K., Dimitris Charitos, Voltnoi and T. Evgeniou³.

³ In this multiple installation which was first presented at a the Cheap Art gallery in Athens (2003), certain found objects (a stove, a washing machine and other kitchen white goods) are transformed into interactive audio making mechanisms supporting user involvement of visitors into the way the auditory

7. Conclusion

As we are witnessing a gradual integration of computational technology with elements of our daily urban space, we need to find new ways of designing meaningful interaction of users with these technological artifacts and the environments that they determine, by virtue of their location and form. This paper provides an overview of the main aspects and issues that constitute the integration of cultural theories and approaches into the design practice of computational objects and spaces. Moreover, the experience of being and acting in the world is discussed from a phenomenological perspective. Theories and practices concerned with critical theory can help researchers, designers and users to think about how they may utilise the knowledge they acquire from interacting with artifacts, in order to create meaningful engagements.

Design research focusing on interaction with computational artifacts and spaces can benefit from the engagement of criticism in provoking action and raising awareness regarding the interaction process and ultimately for proposing new ways of designing, building and living in our environment. Critical design can provide the framework for further exploring the possible challenges of new emerging technological environments, setting in this regard the debate among researchers, encouraging experimentation on the interaction design process and transforming the way we conceptualise of and experience interaction with computational artifacts and within the spaces they determine.

References

- [1] P. Antonelli, *Design and the elastic mind*, NewYork: The Museum of Modern Art, ed. 2008.
- [2] A. Balsamo, *Design*, *International Journal of Learning and Media*, vol. 1, no. 4, 1-10.
- [3] J. Bardzell, J. Bolter, and J. Löwgren, Interaction criticism: three readings of an interaction design, and what they get us, *Interactions*, vol.17, issue 2, (2010) 32-37.
- [4] J. Bardzell, Interaction criticism and aesthetics, Proceedings of the SIGCHI Conference on *Human Factors in Computing Systems*, 2357-2366, 2009.
- [5] G. Bell, M. Blythe, and P. Sengers, Making by Making Strange: Defamiliarization and the Design of Domestic Technologies, *ACM Transactions on Computer-Human Interaction*, vol. 12, no. 2, June 2005, 149-173.
- [6] F. D. K Ching,. (1979) *Architecture: Form, Space and Order*. Van Nostrand Rheinhold: London. p.108
- [7] M. Crang, and S. Graham, Sentient cities : ambient intelligence and the politics of urban space, *Information, communication society.*, vol.10 no.6, 789-817, 2007.
- [8] K. Diamantaki, C. Rizopoulos, D. Charitos, N. Tsianos, Theoretical and methodological implications of designing and implementing multiuser location-based games, *Personal and Ubiquitous Computing*, vol. 15, no. 1, 37-49, Springer, 2011.
- [9] C. DiSalvo, *Adversarial Design*, The MIT Press, 2012.
- [10] J. Lukens, and C. DiSalvo, Speculative Design and Technological Fluency, *International Journal of Learning and Media*, vol. 3, no. 4, 23-40, 2012.
- [11] A. Dunne, and F. Raby, *Technological Dreams Series: No.1, Robots*, 2007, [<http://www.dunneandraby.co.uk/content/projects/10/0>]
- [12] A. Dunne, *Hertzian Tales: Electronic Products, Aesthetic Experience and Critical Design*, RCA Press, London, UK, 2005.
- [13] A. Dunne, and F. Raby, *Design Noir: The Secret Life of Electronic Objects*, Birkh`auser, Baseil, Switzerland, 2001.

composition evolves in real time. Sensors are appropriately positioned in all of these devices and the production of the auditory composition is partly affected by user interaction with these objects. For more info see: <http://www2.media.uoa.gr/~charitos/artworks/tonhome.html>

- [14] W. Gaver, J. Bowers, A. Boucher, A. Law, S. Pennington and B. Walker, Electronic Furniture for the Curious Home: Assessing Ludic Designs in the Field, *International Journal of Human-Computer Interaction*, vol. 22 issue 1-2, 119-152.
- [15] W. Gaver, P. Sengers, T. Kerridge, J. Kaye, and J. Bowers, Enhancing Ubiquitous Computing with User Interpretation: Field Testing the Home Health Horoscope, Proceedings of the *SIGCHI conference on Human factors in computing systems*, April 05-10, 2003, Ft. Lauderdale, Florida, USA.
- [16] W. Gaver, J. Beaver, and S. Benford, Ambiguity as a resource for design, In Proceedings of *Computer Human Interaction*, 2003, 233-240.
- [17] W. Gaver, T. Dunne, and E. Pacenti, Cultural probes, *Interactions*, vol. 1, 1999.
- [18] W. Gaver, Affordances for interaction: The social is material for design, *Ecological Psychology* vol.8 no. 2, 111-129, 1996.
- [19] J. J. Gibson, *The Ecological Approach to Visual Perception*, Lawrence Erlbaum Associates, London, (1986) first published in 1979, p.111
- [20] E. Hornecker, and J. Buur, Getting a grip on tangible interaction: a framework on physical space and social interaction, In: Proceedings of ACM CHI 2006 *Conference on Human Factors in Computing Systems*, 437-446, 2006.
- [21] J. 'J' Kaye, and L. Goulding, Intimate Objects, Proceedings of DIS'04, ACM Press, 2004.
- [22] Lefebvre, H. (1997), Extracts from "The Production of Space", in Leach, N. (1997), *Rethinking Architecture: A Reader in Cultural Theory*, pp.138-146.
- [23] J. Lukens, and C. DiSalvo, Speculative Design and Technological Fluency, *International Journal of Learning and Media*, vol. 3, no. 4, 23-40.
- [24] M. McCullough. On attention to surroundings, *Interactions*, vol. 19 issue 6, pp. 40-49, 2012.
- [25] Merleau-Ponty, M. (1962) *The Phenomenology of Perception*, Routledge: London, pp.243-4.
- [26] Norberg-Schulz, C. (1971) *Existence, Space and Architecture*, Praeger Ltd, New York.
- [27] D. Norman, *The Design of Everyday Things*, MIT Press, London, UK, 1998.
- [28] Piaget, J. (1954) *The child's construction of reality*, Routledge & Kegan Paul, London. , p.92.
- [29] C. Rizopoulos, D. Charitos, Implications of Theories of Communication and Spatial Behavior for the Design of Interactive Environments, IE '11 Proceedings of the 2011 *Seventh International Conference on Intelligent Environments*, 92-99, 2011.
- [30] P. Sengers, Practices for machine culture: A case study of integrating artificial intelligence and cultural theory, *Surfaces*. Vol. VIII, 1999.
- [31] P. Sengers, and W. Gaver, Staying Open to Interpretation: Engaging Multiple Meanings in Design and Evaluation, In Proceedings of the *Sixth Conference on designing Interactive Systems*, University Park, PA, 99-108, 2006.
- [32] B. Sterling, Design Fiction, *Interactions*, vol. 16, no. 3, pp. 20-24.
- [33] Thiel, P. (1961) "A sequence-experience notation", *Town Planning Review*, vol. 32, April 1961.
- [34] T. Winograd, From Computing Machinery to Interaction Design, *Beyond Calculation: The Next Fifty Years of Computing*. Eds. Peter Denning nad Robert Metcalf. SpringerVerlag, 149-162, 1997.
- [35] J. Zimmerman, J. Forlizzi and S. Evenson, Research through design as a method for interaction design research in HCI, Proceedings of the SIGCHI conference on Human factors in computing systems, April 28-May 03, 2007, San Jose, California, USA.

Modeling context and fuzzy personas towards an intelligent Future Internet smart home paradigm

Phivos MYLONAS¹, Giorgos SIOLAS, George CARIDAKIS, Stefanos KOLLIAS
and Andreas-Georgios STAFYLOPATIS

*Intelligent Systems, Content and Interaction Laboratory
National Technical University of Athens, Greece
Iroon Polytechneïou 9, Zographou Campus, Athens, Greece
<http://www.image.ntua.gr>*

Abstract. It is rather true that the advent and wide proliferation of ubiquitous computing in the recent years has promoted the concept of intelligent computational social interaction as an important influencing factor of the way end-users, organizations and devices interact with each other within the new digital era. Among fields influenced is that of “smart cities” or the so-called “cities of tomorrow”, where the increase and maintenance of citizens’ active participation in the organization’s knowledge management activities is pursued through the adoption of social computing approaches. Since cities are composed by people that inhabit them, their memories, stories, concerns and culture developing through their social interaction is of great research interest. In this paper we discuss our early efforts on designing, modeling and providing a prominent and applied knowledge modeling personalization approach, in order to achieve an ultimate goal, that of providing innovative personalized services to citizens and enhancing their everyday life within the above framework. Thus, herein we propose a novel representation way to exploit its knowledge generation and sharing capabilities in order to effectively capture and formalize corresponding knowledge information.

Keywords. knowledge management, user modeling, fuzziness, Future Internet, smart cities

Introduction

In an effort to summarize the main goal of our research work, one would agree that this paper discusses a user-centered perspective within the Internet of Things (IoT) framework. More specifically, a complete ecosystem of users within a social network is exploited and adopted within the European FP7 project “Social&Smart” in order to develop a so-called collective intelligence and adapt its operation through appropriately processed feedback. The ultimate aim is for the user to collectively (via the social network) and intelligently (via the adaptive network intelligence) interface, and finally control, her/his household appliances, contributing to the smart home/city paradigm. The

¹Corresponding Author: Phivos Mylonas; E-mail: fmylonas@image.ntua.gr

central role of users is reflected on all aspects of such an ecosystem, from the family of Things that are socially governed, to the household appliances that affect our everyday life, and up to the employed hardware and software.

If we were to follow traditional user modeling researches that would have ranged from exploring reasoning approaches to different propositions towards building user models, both through establishment of meaningful user interfaces, as well as through machine learning techniques and exploration of user modeling systems. The main principle behind the notion of user modeling is the fact that having a good list of users may help us understand the functional scope of an ecosystem. For instance, questions such as "how many different types of users will use this software/hardware?", "what goals will they be in pursuit of?", "what tasks will they need to perform?", "which of those tasks will the software support?", etc. may be well answered through a well-defined user modeling scheme.

The latter stresses the fact that it is really important for user-based smart ecosystems, such as the one under examination herein, to collect and provide information about its users. Lacking information about users, such an ecosystem will not be able to adapt itself to the users' characteristics and preferences, failing to evolve and provide meaningful services. Typically, such types of required information are stored and managed in form of user models. Thus, in principle a user model represents the ecosystem's viewpoint about users. One of the fundamental questions still to be answered during the construction and content identification process of user models is *how do we go about describing users in the most semantically-relevant way?* Again, within typical use case modeling scenarios, actors are people who interact with a system; they're often described using job titles or a common name for the type of user. A user role refers, in general, to a user's responsibility when using a piece of software or participating in a business process. This relationship may be between a person and their organization, a business process, a software/hardware tool or any other entity. It should be noted at this point that there are three important dimensions that characterize user models and have been identified as early as 1979 by Rich [1], namely:

- One model of a single canonical user vs. a collection of models of individual users.
- Models specified explicitly vs. models inferred by the system on the basis of user behavior.
- Long-term user models that represent demographics or general interests of users vs. short-term user models that are suitable for a specific session or task.

Moreover, according to one of the very first user model definitions, a user model is composed by information specific to each individual user, which describes specific user features [2]. Through the user model, the system may distinguish between different users and adapt itself to the particular user needs. In order to identify a meaningful way of describing the inherent uncertainty of the latter observation, we propose a *fuzzy* user model to deal with vagueness in users' needs and knowledge descriptions. Without such information deriving from the user model, all users would be treated equally [3]. A perfect user model would include all real-life features of users' behavior and knowledge that affect their performance and efficiency. However, because the construction of such complex model is typically considered to be a very difficult task, simplified models are used in practice. Keeping in mind the three aspects that have to be considered regarding

a user model [4], namely: a) what type of information about the user is included in the model and how it is obtained, b) the representation of this information within the particular ecosystem, and c) the process of forming and updating the model, in the following we 'll attempt to tackle the first two of them.

The remaining of this paper is organized as follows: in Section 1 we provide a summary of related research works. In Section 2 we give a brief overview of the architectural framework of "Social&Smart" endorsed herein, whereas in Section 3 we discuss the users' real-life perspective and how users may be modeled through a number of fuzzy user profiles. Finally the role of context and how it influences the overall process is discussed in Section 4, where our concluding remarks and ideas on future works are contained in Section 5.

1. Related works

Although, by definition the tasks of user and task modeling and analysis are not heavily related, it is not unusual for one modeling study to influence the other, especially during advanced iterative design cycles and usability analysis of systems that are being used. Within the exploited "Social&Smart" framework, both approaches will be considered during both its social network design and small scale mock-up phases for users and usage design approaches, respectively. In many cases, we are not interested in user modeling in a general sense, but only in user performance (task) and background knowledge with respect to tasks in a certain domain (context). In this case, an adequate user model may be restricted to a small set of user attributes related to a specific task. Kobsa revised generic user modeling systems in [5], in terms of their design approach and implementation into adaptive and personalized systems. This survey discusses approaches varying from definition of hierarchically ordered user stereotypes (e.g., "personas") and rules (using first order logic) for user model inferences to generalizing and extrapolating data collected from unobtrusive online user input.

Introduced by Cooper [6] early *personas* were rough sketches, but over time his method evolved to include interviews or ethnography to create more detailed characters. This initial methodology was extended and applied to popular operation systems and software such as MSN Explorer and Windows [7] or even EuropeanaConnect, a Best Practice Network funded by the European Commission ². A totally different approach attempts to model extreme characters, rather than users sharing common characteristics, considering radical personalities [8].

Furthermore, [9] discusses a number of challenges for machine learning that have hindered its application in user modeling and reviews approaches to resolving them, namely, the requirement for large and labeled data sets of high dimensionality as well as computational complexity restrictions for online applications and capability of adjusting to highly dynamic interaction environments, to name a few. World Wide Web and Social Networks are by definition such interaction environments. The usage modeling approach [10] attempts to tackle this aspect of user modeling. Whereas user-centered design makes users per se the center of attention and seeks to promote user satisfaction with the entire user experience, usage-centered design is more narrowly focused on user performance.

²EuropeanaConnect, <http://www.europeanaconnect.eu/>, last retrieved: April 2013

In usage-centered design the models are in the foreground with user studies and user involvement in the background.

With respect to the inherit contextual information available, authors of [11] reviewed an impressive 423 (out of 1419) articles related to context-aware approaches in literature and compiled a survey of the research area also proposing a classification framework. Their research also indicates the increasing amount of attention, corresponding to both its importance and dynamics, the area has received from the academic community. The authors concluded that most of the research performed in the area is focused on the Application and Concept layers, although Application and Interface layers tend to converge.

Most of the above context-aware systems focus on the external context, called physical context. External context means context data collected by physical sensors. It involves context data of the physical environment, location data, distance, function on to other objects, temperature, sound, air pressure, time, lighting levels surrounding users, and so on. However, a few authors have addressed utilizing the cognitive elements of a user's context. Various algorithms used in context-aware systems are classified into two parts. First, algorithm is utilized to infer high-level context of user. According to levels of abstraction, context is divided into low-level context and high-level context. Low-level context is raw data collected directly from physical sensors, while high-level context is inferred from low-level context. Although context awareness is important, context management and its integration is also crucial to achieving optimal user experience. There is no sense gathering and analyzing all the input representing the context without utilizing it appropriately. This can be accomplished by fusing the context and user modeling for personalized services and systems [12]. The authors study the integration and fusion of contextualization which complements personalization, based on user modeling, so that environmental states or the context of use can also be taken into account

In [13] authors propose an agent-based framework for providing the personalized services on context-aware computing, utilizing the extracted users' preferences and association rules. Data gathering layer collects and processes the users' profiles such as sex, age, job and hobby, the raw contexts (sensed data) such as time, location and temperature, and the selected services by the users such as destination. Context management layer infers the current high-level context processing the raw context and classifies the users' profile and services according to the reasoned high-level context using the filtering agent. Finally, in [14] the authors designed and developed ContextPhone, a software platform consisting of interconnected modules provided as a set of open source libraries for Symbian OS, residing between the application and device layer.

2. Basic ecosystem architecture

Within the framework of "Social&Smart", a *Networked Intelligence* module collects feedback from users regarding their satisfaction from recipes from one side, and responses from appliances themselves, on the other side, thus forming a permanent recipe optimization loop with offline advices and suggestions from the part of appliance manufacturers. In principle, the architecture of "Social&Smart" may be divided into three layers 1, namely: *lower*, *middle* and *top*. The lower layer is formed by all actual devices such as a fridge, a washing machine, a microwave oven etc., where each one is abstracted by what we call a Unified-Node (UN). The UN is the first level of device abstraction. Its

role is to: i) uniquely identify a device, ii) represent the device in terms of its properties, and iii) constitute a bidirectional gateway for all communication between devices and middleware.

The middle layer is constituted by a set of modules, variously interconnected to interpret and control the commands issued by the users. To this aim, the latter must interface with any device found in the home, i.e. any UN representing an actual device. It must be capable both of managing and interfacing with devices gathered in logical clusters, such as all the devices located in a certain room, and of processing logical rules for adapting optimally the instructions to the devices specifications and limitations. The above modules will support these functionalities in two different modes, instantaneous commands, and recipe execution. The appliances' interface will be enhanced in terms of semantics via processing of recipes and rules by the knowledge base; the latter serves also as an intelligent conflict resolution mechanism that decides on future actions, thus resolving a conflict of resource/appliance allocation, which could lead to potential resource deadlocks. Recipes are transformed into explicit instructions to appliances, implementing a richer – compared to the one provided by the UN appliance abstraction – description for all domestic devices.

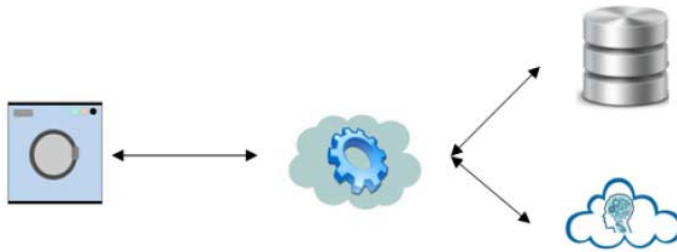

Figure 1. Abstract depiction of layers.

At the top layer, users interact with the middleware through a proper front-end either individually, e.g., a user sending recipes to his home, or through the users' community social network. From the "Social&Smart" point of view, a social network is a large database, i.e. the users' database, with an inquiry system based on advanced clustering algorithms. Exploiting this basis, one may build a series of services, such as automatic friend finding, proposal of interest groups, forums, etc.. The two elements that set apart the community social network are the way it fills the database and the main service it offers.

In principle, subscribing to a common social network, such as Facebook, requires to enter a series of personal data that form the user profile. Providing this information is in general optional for the user. The user may want to enrich his profile both to give other users means for discovering him as a friend and to increase his appeal (for instance by publishing interests, activities etc.). Quite on the contrary, a user registers into the "Social&Smart" community social network almost automatically. Once he contacts the social network he receives an ID and is roughly geo-localized. The same occurs in the case of a single appliance, thanks to smart appliance self-discovery facilities. To these basic data, additional ones may be optionally added, which mainly concern practical aspects of the homes, for example the floor plan indicating where the appliances are

located (to rule the appliances noise) or the maximum power supplied by the electrical meter (to avoid overloads). Each time the user asks for a recipe, she/he enriches her/his profile; the same holds for user feedbacks. Of course, a recipe request must be entered by the user. But this is neither burdensome (because it is rewarded by the recipe), nor arbitrary (because only valuable and exact information needs to be entered). Finally, there is no need for strict personal identification of users. On the other hand, appliances must be completely identified through technical sheets supplied by their manufacturers (or every available documentation in the early implementations), as they constitute a part of the database which will be inquired during the creation of the recipes. Finally, typical social network services will be provided, initiating various forms of information exchanges such as friendship, files, forums etc. Of course, in such an environment, the main (possibly, sole) service provided to users will be recipe generation.

3. Fuzzy user models

Towards a rather simplified user model to be used in practice, an efficient user model representation formalism, such as ontologies ([15]), presents a number of advantages. In the context of the current work, ontologies are suitable for expressing user modeling semantics in a formal, machine-processable representation. As an ontology is considered to be "a formal specification of a shared understanding of a domain", this formal specification is usually carried out using a subclass hierarchy with relationships among classes, where one can define complex class descriptions (e.g. in Description Logics (DLs) [16] or Web Ontology Language (OWL) in [17]). Amongst all possible ways to describe ontologies, one may be formalized as:

$$O = \{C, \{r_{ab}\}\}, \text{ where } r_{ab} : C \times C \rightarrow \{0, 1\} \quad (1)$$

In equation (1), O is an ontology, a and b are two concepts (i.e., user models) belonging to the set C of concepts described by the ontology and r_{ab} is the semantic relation amongst these concepts. The proposed knowledge model is based on a set of concepts and semantic relations between them, that form the basic elements towards semantic interpretation of user models. Although almost any type of relation may be included to construct such knowledge representation, the two categories commonly used are taxonomic (i.e., ordering) and compatibility (i.e., symmetric) relations. However, as extensively discussed in the literature (e.g., in [17]), compatibility relations fail to assist in the determination of the context and the use of ordering relations is considered a necessity for context-aware user modeling tasks.

A last important point to consider when designing such a knowledge user model is the fact that real-life data often differ from research data. Real-life information is in principal governed by notions, such as *uncertainty* and *fuzziness*, thus its modeling should be based on *fuzzy* relations, as well. To tackle this observation and as a means to take into account the approximative nature and the inherent uncertainty involved in the interpretation of user needs and user wishes in a formal way, we propose the introduction of fuzzy representations, based on fuzzy theory ([18], [19]), as a formal grounding for the development of our user model. Thus, we propose a fuzzification of the previous ontology definition, as follows:

$$O_F = \{C, \{R_{ab}\}\}, \text{ where } R_{ab} = F(r_{ab}) : C \times C \rightarrow [0, 1] \quad (2)$$

In equation (2), O_F defines a fuzzified ontology, C is again the set of all possible concepts (i.e., user models) it describes and R_{ab} denotes a fuzzy semantic relation amongst the two concepts a and b . The latter depicts the fact, that, even when the meaning is clear, relations among real-life concepts are often a matter of degree, and one way to efficiently represent and model them is by the use of fuzzy relations.

Given a universe \mathcal{V} of users \mathcal{U} , a crisp (i.e., non fuzzy) set S of concepts on \mathcal{V} is described by a membership function $\mu_S : \mathcal{V} \rightarrow \{0, 1\}$. The crisp set S may be defined as $S = \{s_i\}$, $i = 1, \dots, N$. A fuzzy set F on S may be described by a membership function $\mu_F : S \rightarrow [0, 1]$. We may describe the fuzzy set F using the well-known sum notation for fuzzy sets [20] as:

$$F = \sum_i s_i/w_i = \{s_1/w_1, s_2/w_2, \dots, s_n/w_n\} \quad (3)$$

where:

- $i \in N_n$, $n = |S|$ is the cardinality of the crisp set S ,
- $w_i = \mu_F(s_i)$ or, more simply $w_i = F(s_i)$, is the membership degree of concept $s_i \in S$.

Consequently, equation (3) for a concept $s \in S$ may be transformed equivalently as:

$$F = \sum_{s \in S} s/\mu_F(s) = \sum_{s \in S} s/F(s) \quad (4)$$

Let now \mathcal{R} be the crisp set of fuzzy relations defined as:

$$\mathcal{R} = \{R_i\}, R_i : S \times S \rightarrow [0, 1], \quad i = 1, \dots, M \quad (5)$$

Then the proposed fuzzy ontology contains concepts and relations and may be formalized as follows:

$$\mathcal{O} = \{S, \mathcal{R}\} \quad (6)$$

In equation (6), \mathcal{O} is a fuzzy ontology, S is the crisp set of concepts described by the ontology and \mathcal{R} is the crisp set of fuzzy semantic relations amongst these concepts.

Given the set of all fuzzy sets on S , \mathcal{F}_S , then $F \in \mathcal{F}_S$. Let \mathcal{U} be the set of all users \hat{u} in our framework, i.e. a user $\hat{u} \in \mathcal{U}$. Let \mathcal{P} be the set of all user meanings and $\mathcal{P}_\mathcal{O}$ be the set of all user meanings on \mathcal{O} . Then $\mathcal{P}_\mathcal{O} \subset \mathcal{F}_S$ and $\mathcal{P}_\mathcal{O} = \mathcal{F}_Z \subset \mathcal{F}_S$, whereas $P_{\hat{u}} \in \mathcal{P}_\mathcal{O}$ depicts a specific user model.

3.1. Fuzzy semantic relations

At this point, where tolerance to imprecise descriptions is an assumed given, the relations between model concepts take on a key role in harnessing the degree of fuzziness involved in the discussed framework and help us handle this uncertainty. As a novel contribution, we propose an enhancement based on the exploitation of fuzzy ontological information as a source of semantic information and/or an aid to relate different parts of the user modeling process. The extra semantics (precise classification, explicit fuzzy relations between concepts) supply a rich source of additional knowledge, enabling significant

improvements with respect to the results that can be achieved by the use of unrelated or crisp plain concepts. Under this interpretation, in order to define, extract and use both a set of concepts, we rely on the semantics of their fuzzy semantic relations. As discussed in the previous subsection, a *fuzzy binary relation* on S is defined as a function $R_i : S \times S \rightarrow [0, 1], i = 1, \dots, M$. The inverse relation of relation $R_i(x, y), x, y \in S$ is defined as $R_i^{-1}(x, y) = R_i(y, x)$. We use the prefix notation $R_i(x, y)$ for fuzzy relations, rather than the infix notation xR_iy , since the reader is considered to be more familiarized to the former. The *intersection*, *union* and *sup- t composition* of any two fuzzy relations R_1 and R_2 defined on the same set of concepts S are given by:

$$(R_1 \cap R_2)(x, y) = t(R_1(x, y), R_2(x, y)) \tag{7}$$

$$(R_1 \cup R_2)(x, y) = u(R_1(x, y), R_2(x, y)) \tag{8}$$

$$(R_1 \circ R_2)(x, y) = \sup_{w \in S} t(R_1(x, w), R_2(w, y)) \tag{9}$$

where t and u are a fuzzy t -norm and a fuzzy t -conorm, respectively. The standard t -norm and t -conorm are the *min* and *max* functions, respectively, but others may be used if appropriate. The operation of the union of fuzzy relations can be generalized to a number of M relations. If R_1, R_2, \dots, R_M are fuzzy relations in $S \times S$ then their union R^u is a relation defined in $S \times S$ such that for all $(x, y) \in S \times S, R^u(x, y) = u(R_i(x, y))$. A transitive closure of a relation R_i is the smallest transitive relation that contains the original relation and has the fewest possible members. In general, the closure of a relation is the smallest extension of the relation that has a certain specific property, such as the reflexivity, symmetry or transitivity, as the latter are defined in [19]. The sup- t transitive closure $Tr^t(R_i)$ of a fuzzy relation R_i is formally given by:

$$Tr^t(R_i) = \bigcup_{j=1}^{\infty} R_i^{(j)} \tag{10}$$

where $R_i^{(j)} = R_i \circ R_i^{(j-1)}$ and $R_i^{(1)} = R_i$. It is proved that if R_i is reflexive, then its transitive closure is given by $Tr^t(R_i) = R_i^{(n-1)}$, where $n = |S|$ [19].

Based on the relations R_i we first construct the following combined relation T , to be further utilized in the definition of context C :

$$T = Tr^t(\bigcup_i R_i^{p_i}), \quad p_i \in \{-1, 0, 1\}, \quad i = 1 \dots M \tag{11}$$

where the value of p_i is determined by the semantics of each relation R_i used in the construction of T . More specifically:

- $p_i = 1$, if the semantics of R_i imply it should be considered as is,
- $p_i = -1$, if the semantics of R_i imply its inverse should be considered,
- $p_i = 0$, if the semantics of R_i do not allow its participation in the construction of the combined relation T .

The transitive closure in equation (11) is required in order for T to be taxonomic, as the union of transitive relations is not necessarily transitive, independently of the fuzzy t -conorm used. In the above context, a fuzzy semantic relation defines, for each element $s \in S$, the fuzzy set of its ancestors and its descendants. For instance, if our knowledge

states that "JFK assassination" is before "Bosnia war" and "Bosnia war" is before "9/11 attack", it is not certain that it also states that "JFK assassination is before "9/11 attack". A transitive closure would correct this inconsistency. Similarly, by performing the respective closures on relations that correlate pair of concepts of the same set, we enforce their consistency.

For the purpose of analyzing textual descriptions, relation T has been generated with the use of a small set of fuzzy taxonomic relations, whose semantics are derived primarily both from the MPEG-7 standard and specific "Social&Smart" user requirements and are summarized in Table 1. This approach is ideal for the user modeling interpretation followed herein; when dealing with generic user information, focus is given on the semantics of high level abstract concepts.

Table 1. Fuzzy semantic relations used for generation of combined relation T .

Name	Inverse	Symbol	Meaning	Example	
				a	b
Specialization	Generalization	$Sp(a, b)$	b is a specialization of a	appliance	fridge
Part	PartOf	$P(a, b)$	b is a part of a	house	bathroom
Example	ExampleOf	$Ex(a, b)$	b is an example of a	fridge	Siemens
Instrument	InstrumentOf	$Ins(a, b)$	b is employed by a	clean	vacuum cleaner
Location	LocationOf	$Loc(a, b)$	b is the location of a	cooking	kitchen
Patient	PatientOf	$Pat(a, b)$	b undergoes the action of a	give	dust-buster
Property	PropertyOf	$Pr(a, b)$	b is a property of a	washing machine	rpm program

The aforementioned relations are traditionally defined as crisp relations. However, in this work we consider them to be fuzzy, where fuzziness has the following meaning: high values of $Sp(a, b)$, for instance, imply that the meaning of b approaches the meaning of a , while as $Sp(a, b)$ decreases, the meaning of b becomes narrower than the meaning of a . A similar meaning is given to fuzziness of the rest semantic relations of Table 1, as well. Based on the fuzzy roles and semantic interpretations of R_i , it is easy to see that aforementioned relation (11) combines them in a straightforward and meaningful way, utilizing inverse functionality where it is semantically appropriate:

$$T = Tr^l (Sp \cup P^{-1} \cup Ex \cup Ins \cup Loc^{-1} \cup Pat \cup Pr) \quad (12)$$

Relation T is of great importance, as it allows us to define, extract and use contextual aspects of a set of concepts. All relations used for its generation are partial taxonomic relations, thus abandoning properties like synonymity. Still, this does not entail that their union is also antisymmetric. Quite the contrary, T may vary from being a partial taxonomic to being an equivalence relation. This is an important observation, as true semantic relations also fit in this range (total symmetricity, as well as total antisymmetricity often have to be abandoned when modeling real-life relationships). Still, the taxonomic assumption and the semantics of the used individual relations, as well as our experiments, indicate that T is "almost" antisymmetric and we may refer to it as ("almost") taxonomic. Relying on its semantics, one may define the context C of a single concept $s \in S$ as the set of its antecedents provided by relation T in the ontology. Considering the semantics of the T relation, it is easy to realize that when the concepts in a set are highly related to a common meaning, the context will have high degrees of membership for the concepts that represent this common meaning. Understanding the great importance of

latter observation, we plan to further investigate and integrate such contextual aspects of user models in our future work.

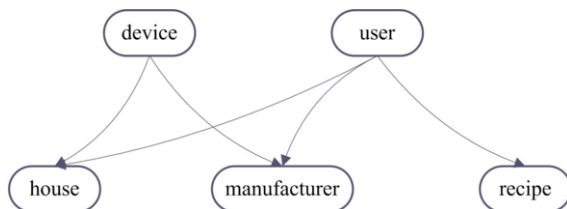

Figure 2. Concepts and relations example; concepts *device* and *user* are the antecedents of concepts *house* and *manufacturer* in relation *T*, whereas concept *user* is the only antecedent of concept *recipe*.

4. The role of context

The notion of context in our framework consists of a fuzzy region of an ontology, and is used to help focus or extend the ecosystem interpretation of user interests to a specific semantic area. In the profiling phase, which takes place off-line, the ecosystem detects user preference patterns by analyzing a large set of recorded user actions and requests. The ecosystem analyzes the semantic relations to find common thematic ground for different subsets of the usage history, e.g., in a clustering-based approach. The contextual notion implied here is taxonomic and of restrictive nature, and is used to reduce noise and uncertainty, by ignoring irrelevant user actions, and focusing on the most cohesive ones, from which it is safer to predict user interests. The context refers to whatever is semantically common among a set of elements, which may refer to the common meaning of a set of concepts, or to the overall topic of a document, respectively. When using an ontological knowledge representation, as the one proposed herein, to interpret the meaning of an information object, it is this type of context of a concept that provides its truly intended meaning. In other words, the true source of information is the semantic commonalities of certain concepts and not each one independently. The common meaning of concepts is thus used to best determine either their topics, or the associated user preferences to which they should be mapped.

Given the set of all fuzzy sets on S , \mathcal{F}_S , then $F \in \mathcal{F}_S$. Let \mathcal{U} be the set of all users \hat{u} in our personalization framework, i.e. a user $\hat{u} \in \mathcal{U}$. Let \mathcal{P} be the set of all user preferences and \mathcal{P}_θ be the set of all user preferences on θ . Then $\mathcal{P}_\theta \subset \mathcal{F}_S$ and $\mathcal{P}_\theta = \mathcal{F}_Z \subset \mathcal{F}_S$, whereas $P_{\hat{u}} \in \mathcal{P}_\theta$ depicts a specific user preference and is described as a fuzzy set. Since the fact that a user preference is relative to a user is clear, in the following we shall omit \hat{u} as the index variable and use just P for short, as long as the meaning is clear.

Furthermore, let \mathcal{C}_θ denote the set of all contexts on θ , $\mathcal{C}_\theta \subseteq \mathcal{F}_S$. Let us also denote the crisp set of concepts characterizing the crisp (taxonomic) context as C , whereas its fuzzy counterpart C provides the context in the form of a fuzzy set of concepts on S , $C \in \mathcal{C}_\theta$. As the last step, we define the contextualization of user preferences as a mapping $\Phi : \mathcal{P} \times \hat{C} \rightarrow \mathcal{P}$ so that for all $p \in \mathcal{P}$ and $c \in \hat{C}$, $p \models \Phi(p, c)$. In this context the entailment $p \models q$ means that any consequence that could be inferred from q could also be inferred from p . For instance, given a user $\hat{u} \in \mathcal{U}$, if $P_{\hat{u}} = q$ implies that \hat{u} "likes x " (whatever this means), then \hat{u} would also "like x " if his/her preference was p .

5. Conclusions and discussion

In this paper we attempted to discuss the “Social&Smart” paradigm of the pervasive Future Internet, as seen from the user-centered perspective. The research questions investigated were how users may be modeled through a number of fuzzy knowledge formalisms and how context may be modeled and integrated successfully in the process of, and especially within, the “Social&Smart” intelligent users/homes paradigm. In addition, this formal, machine-processable representation is used in order to define, extract and use both a set of concepts and their fuzzy semantic relations. We further plan to enhance and progress our research efforts on issues raised in Section 4: our scheduled future work includes incorporation of user and context information through a unified semantic representation, forming an adaptation mechanism that aims to provide real-life, intelligent personalized services and optimize the overall “Social&Smart” user experience.

Acknowledgments

This work is supported by the European Commission under contract FP7-317947, Future Internet Research and Experimentation (FIRE) project, “Social&Smart”.

References

- [1] E. Rich, User Modeling via Stereotypes, *Cognitive Science* 3 (1979), 329–354.
- [2] E. Wenger, *Artificial Intelligence and Tutoring Systems*, Morgan Kaufmann, Los Altos, CA 94022, 1987.
- [3] P. Brusilovsky, *Intelligent Tutoring Systems for World-Wide Web*, In *WWW'95 Posters and Demonstrations*, Darmstadt, 1995.
- [4] A. Jameson, Modeling Both the Context and the User, *Personal Technologies* 5(1) (2001), 29–33.
- [5] A. Kobsa, Generic user modeling systems, *User modeling and user-adapted interaction*, 11 (1) (2001), 49–63.
- [6] A. Cooper, *The Inmates are Running the Asylum*, SAMS, 2004.
- [7] J. Pruitt, J. Grudin, Personas: practice and theory, *Proceedings of the 2003 conference on Designing for user experiences*, ACM (2003), 1–15.
- [8] J. P. Djajadiningrat, W. W. Gaver, J. W. Fres, Interaction relabelling and extreme characters: methods for exploring aesthetic interactions, *Proceedings of the 3rd conference on Designing interactive systems: processes, practices, methods, and techniques (DIS '00)*, New York City, New York, USA, (2000), 66–71.
- [9] G. I. Webb, M. J. Pazzani, D. Billsus, Machine Learning for User Modeling, *User Modeling and User-Adapted Interaction* 11 (1-2) (2001), 19–29.
- [10] L. L. Constantine, L. A. D. Lockwood, *Usage-Centered Engineering for Web Applications*, *IEEE Software* 19 (2) (2013), 42–50.
- [11] J. Hong, E. Suh, S. J. Kim, Context-aware systems: A literature review and classification, *Expert Systems with Applications* 36 (4) (2009), 8509–8522.
- [12] J. Zimmerman, *Exploring Social Relationships Between Smart Homes and Their Occupants*, CHI 2005, W15: Social Implications of Ubiquitous Computing, 2005.
- [13] J. Hong, E.-H. Suh, J. Kim, S. Kim, Context-aware system for proactive personalized service based on context history, *Expert Systems with Applications* 36 (2009).
- [14] M. Raento, A. Oulasvirta, R. Petit, H. Toivonen, *ContextPhone: A Prototyping Platform for Context-Aware Mobile Applications*, IEEE, 2005.
- [15] T. R. Gruber, A translation approach to portable ontology specifications, *Knowledge acquisition* 5(2) (1993), 199–220.
- [16] F. Baader, *The description logic handbook: theory, implementation, and applications*, Cambridge University Press, 2003.

- [17] G. Akrivas, G. B. Stamou, S. Kollias, Semantic association of multimedia document descriptions through fuzzy relational algebra and fuzzy reasoning, *IEEE Transactions on Systems, Man and Cybernetics, Part A*, 34 (2) (2004), 190–196.
- [18] L. Zadeh, *Fuzzy Sets*, *Information and control* 8 (1965), 338–353.
- [19] G. Klir, Y. Bo, *Fuzzy Sets and Fuzzy Logic, Theory and Applications*, Prentice Hall, New Jersey, 1995.
- [20] S. Miyamoto, *Fuzzy Sets in Information Retrieval and Cluster Analysis*, Kluwer Academic Publishers, Dordrecht Boston London, 1990.

Open Design Continuum (ODC)

Christos Gourdoukis^a, Spyros Efthymiou^a

^a Faculty of Architecture, National Technical University of Athens

Abstract - OpenDesignContinuum is a research project carried out in the context of our diploma thesis at the School of Architecture, N.T.U.A. It is a digital platform for the emergence of a collective design process. In particular, research focuses on the formation of a network of spaces, sited at the Municipality of Athens that will contribute to the activation of public space and its transformation to a receptor of social collective expressions. Therefore, there is an attempt to orchestrate a design model that encourages citizens to participate in it. In other words, a process of design, construction and management of a network of sites capable of hosting and promoting social events is promoted by the ODC platform. In this direction, necessary and sufficient condition is the involvement of citizens in all phases of the design process.

Keywords - network, collective design, complex hierarchy

1. Model of Design

1.1. Participation

We tried to organize a different model of design, with particular emphasis on the participation of users in the design process and the element of time. An “open collective model” with a design approach of complex hierarchy, as will be described later on. We refer to this model, using terms from General Systems Theory of von Bertalanffy [6]. Thus, we imagine the design process as an open dynamic system [4]. Man as an element -user- of the broader system, required to interact with it. The process which includes user in the decision-making, addresses the property of citizen, thus emphasizing the political characteristics of design. As a result, the insertion of the human element not only as a variable, but also as a sufficient condition to alter the process -open design- causes the system not only to increase its complexity, but also to surpass the predictability of the design outcome. This raises further questions, such as the representation of the unplanned and the unpredictable, to which we will return later on.

1.2. Time

Besides the participation of users in the design process, we stated that the main axis of this model is time. In particular we examined three aspects of time: duration, succession and synchrony [1]. These will help us in the organization of the design model. Succession refers to a linear view of time, associated with the process of implementing an architectural object. The notion of duration is applied to the timeframe given to each step involved in the architectural process. Synchrony refers to aspects of architectural design and the interactions between architects and people that participate in the design process that may occur in parallel.

1.3. Architect

As far as the role of the architect in this model is concerned, there are some changes. The architect needs to act as the orchestrator of the process [3]. The architectural expertise does not disappear; on the contrary, it is organized by defining the framework and margins of interaction with users in the design. This creates a complex hierarchy, a mixture of both a top-down and a bottom up approach that is; as an approach to design, as the architect defines the stages of participation and interaction with the users, but leaves space for the growth of unforeseen events [7].

As a result, we reach the question of definition - representation of this unpredictability. A closed algorithmic process is unable to describe these conditions. How can someone describe an unpredictable changing process? Our research led us to the fact that the only way to understand this uncertainty is through a narrative of a process that has already gone through the phases described. Using terms from systems theory, we apply a developmental approach to the study of the system [4], which means that we keep track of changes occurring to the system in relation to time. Thus we move on to the next stage of the study.

2. Network for housing the collectives in the municipality of Athens

The general model of design proposed above, needs to be addressed to a more specific subject for the continuation of this research and towards reaching its goal, that of interacting with users interested in the design process. The subject we decided to work with, is the city of Athens, because a subject as broad and complex as this, would unravel the obstacles of such an approach to the greatest extent, whereas at the same time, the notion of participatory processes regarding public space is considered of great importance. In particular, a network of constructions-spaces located in the municipality of Athens is proposed and addressed to all its citizens.

2.1. Space

Before we describe the system at the city-network scale, we need to clarify the function of each space-node. (Figure 1.) These nodes aim at activating the potential of the city - human and urban- to address its problems. We could summarize the use of these units as spaces housing collectives. Collectives though, not in terms of closed groups with prescribed goals. On the contrary, recipients of this project are all residents of the municipality of Athens interested in their city. Collectives formed from the common definition of problems that they recognize in their city. The structures-nodes that form the larger network act therefore, as catalysts of social relations, thereby obtaining dual role` both to house and to produce these collectives. The function-behavior takes place around the circle` information / awareness / participation. The units will consist of a framework of certain uses necessary for the operation of the node, and other uses that might arise in the course of the (co) design with the participants. The fixed frame of uses will include ancillary areas, electrical / mechanical installations, and one (or more) space (s) able to accommodate many different uses (screenings, performances, lectures, seminars, debates, etc.).

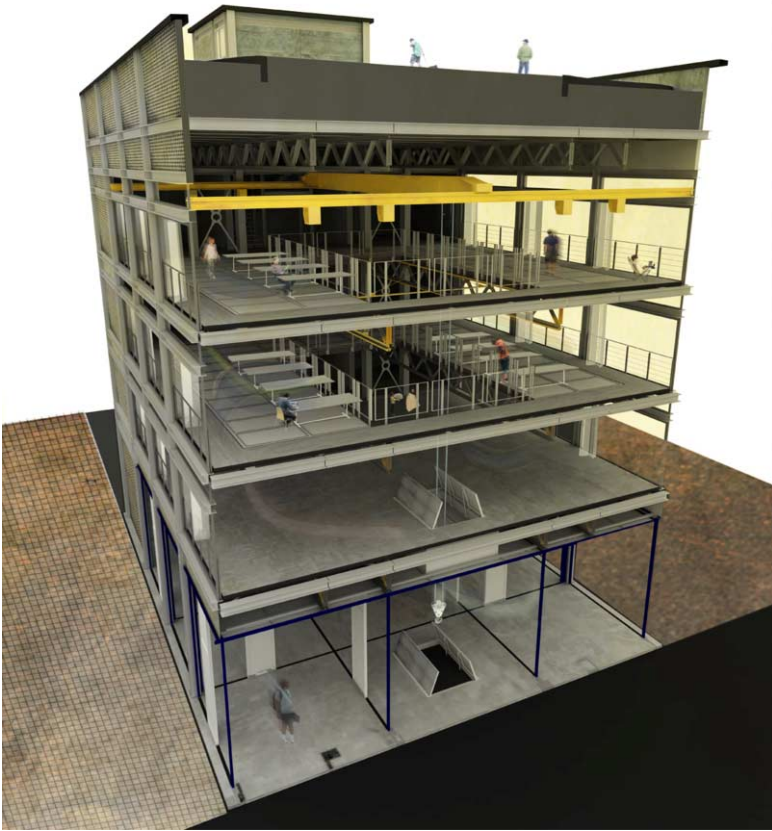

Figure 1. Pilot Node-space

2.2. Network

As already mentioned, spaces as a whole are considered as a network. Networks refer to correlations of entities -material or immaterial-, and are characterized by a set of nodes and the connections between them (Figure 2). The abstract approach of networks, allows us to overcome the limitation of scale and place. This allows the study of heterogeneous elements, regardless of their spatial arrangement, so it is the most widely used tool for scales like that of the city but also for the study of augmented entities [2].

All social sites under the banner of ODC, need to have certain more characteristics for them to work as a network. Specifically, we refer to the links between nodes-spaces. These links are performed through Internet technologies (eg video conferencing) (Figure 3). In this way each node can be connected to any other in order to exchange views, organizing activities etc. This feature leads to the consideration of all nodes as a distributed network. The inherent extendability of the network allows the overcoming of locality and the limited radius of influence of each node-space. A set of sites may deal that way with problems of hyper local character.

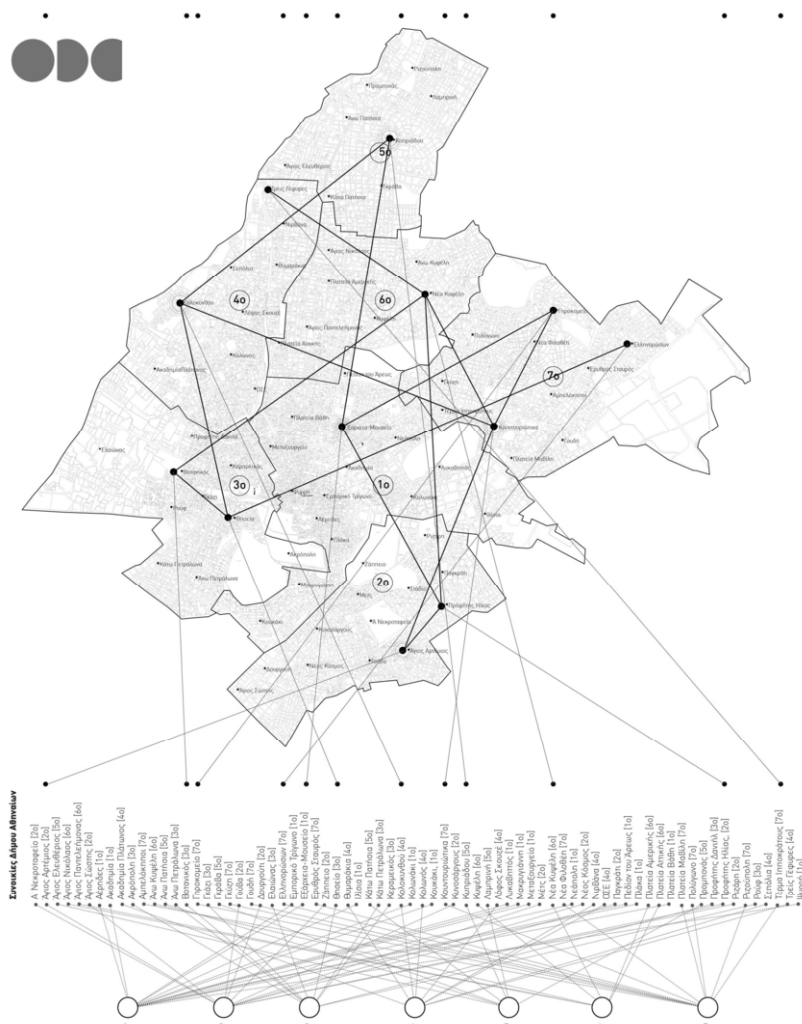

Figure 2. The network

Nodes are the spatial expression of the system, acting as an interface unit between the locality and the overall network. Each node has thereby dual status, both an actual, and a quasi space [5]. The flow of information between the intangible system thus acquires greater significance than the physical structures of this, highlighting the key role played by the internet in similar structures [8].

2.3. Digital Platform

The site OpenDesignContinuum (<http://iktinos3.arch.ntua.gr/odc/>) (Figure 4) is the orchestrator of the overall system. The digital does not replace the real, it only

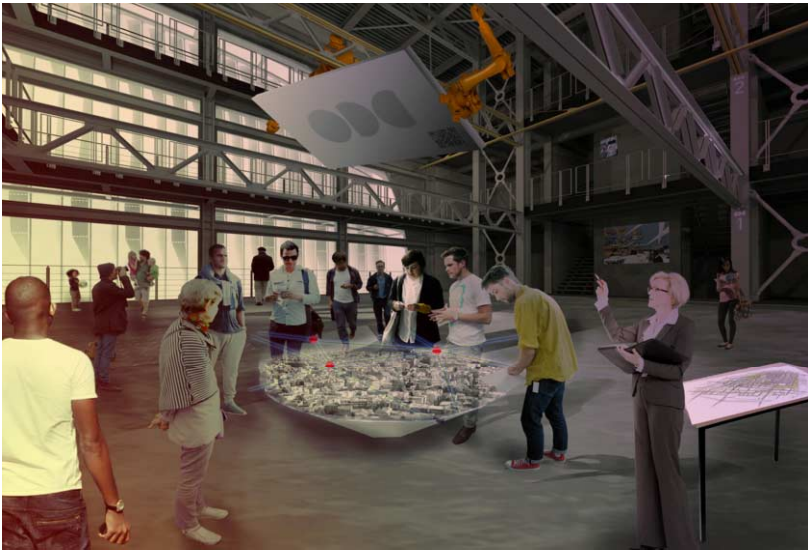

Figure 3. Teleconference between nodes

complements it [5]. The role of the digital platform is summarized in the following two functions. Firstly, it is the means for the realization of collaborative planning. Secondly, it provides the operational context of the overall network, communication between nodes, but also the organization of the behavior of each node separately. These two functions can be separated on the basis of the temporal evolution in the design of each node. Specifically, the boundary point is the time of construction-implementation of each node. Design naturally precedes construction, but does not stop at that stage. Rather, we assume a digital continuum that progresses upon the completion of construction and the management of the structure by the participants involved in it. These two functions at the network level may be performed in parallel as a node can be still at the planning stage, while others may have already been completed.

Users' participation takes place at several stages, which relate to different scales and aspects of design. The first level of separation of the phases of participation, is the division of the process into three categories (location, program and composition). (Figure 5) The division of planning at various stages of interaction allows us to define the scope of interaction between the architect and the users in every one of them. The separation in three independent categories, allows the research team to refine each part separately, while also giving participants the opportunity to interact simultaneously in three categories. This process ensures that the necessary time is given to the system to interact with the participants.

The design process and the results are made available to interested parties through publication on the website. This enhances the openness of the whole enterprise we would like to endow to the page, hoping to work on encouraging the participation of the people in it.

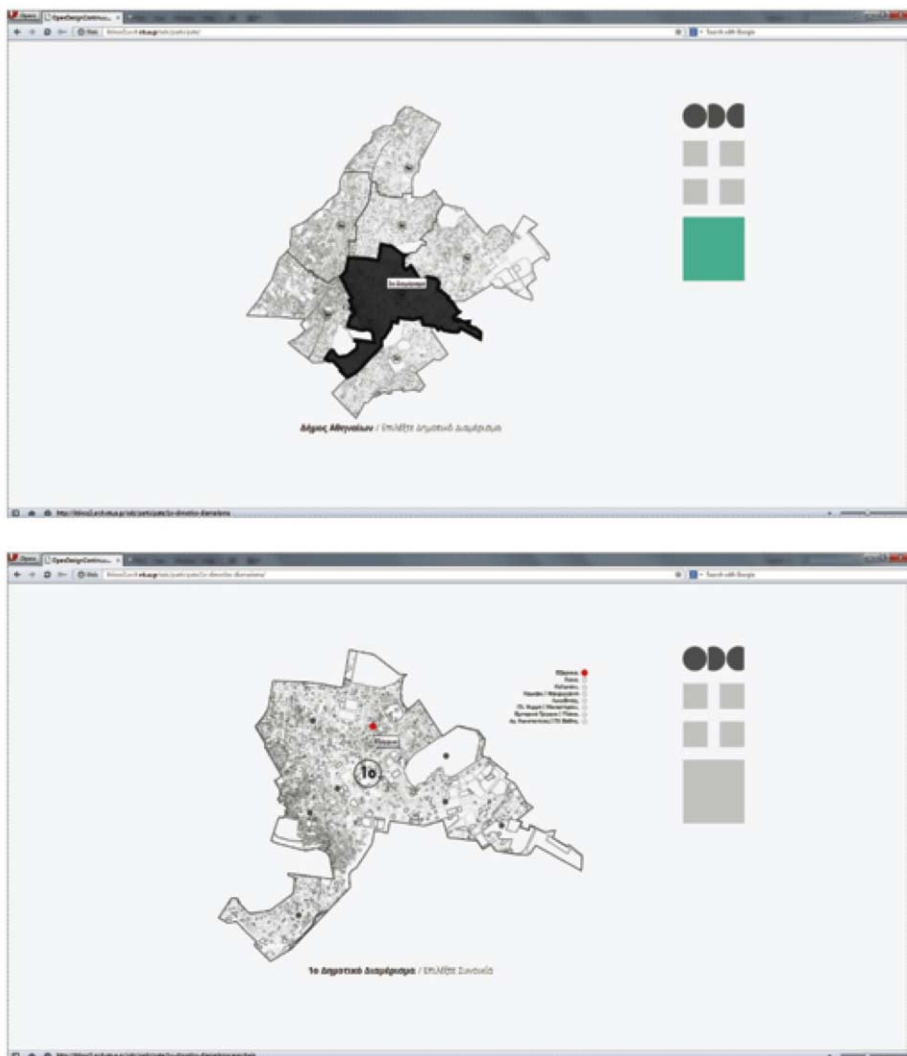

Figure 4. The ODC webpage

3. Conclusions

Having applied the proposed model of design to a specific project, that of ODC, and through the design of a pilot node of the ODC network, we reach to certain conclusions about both attempts.

The first step in the design process is defining the limits inside which the design continuum is allowed to operate. In others words, finding the affordances and constraints on each occasion. These are defined using both a holistic and reductive

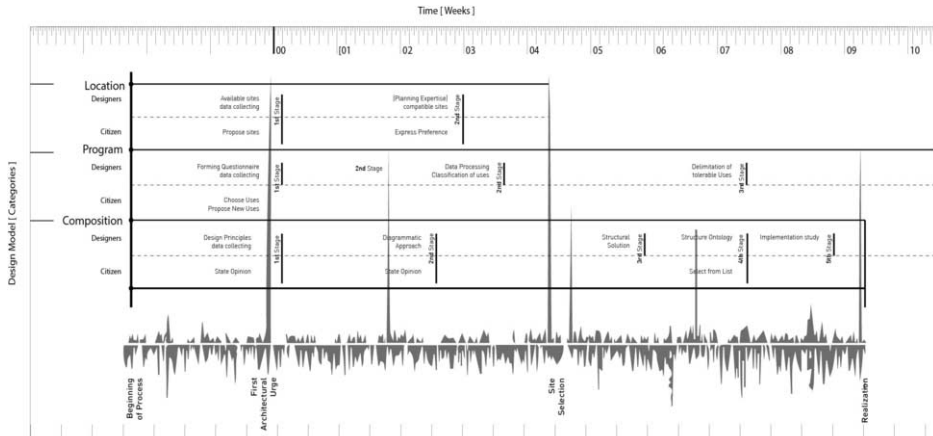

Figure 5. Diagram of the three categories and the interactions with users in relation to time

approach, thus taking into consideration both the general rules and the local demands. In the case of designing a building that needs to be able to host different uses throughout its lifespan we ended up with the idea of designing from the start the maximum allowed by the site iteration of it. As a consequence, the variability wanted was translated into the ability to alter the buildings' interior layout. This in fact solved various technical aspects of the design (statics, networks etc).

The solution proposed was driven towards a system that incorporates change. Therefore, we design the system through which the constant iterations of interior layouts are performed. Variability was defined as an important design principle after the study of the various uses proposed throughout the pilot design process, as well as the will to have a building that is able to transform even after the realization of the project. However, the variability imparted by the specific design should not be confused with the element of open design, which gives the greatest possible interaction with citizens during the design process and refers to the general design model.

The development of an ontology, supports a systemic approach of architecture and creating an architectural vocabulary that enables collaboration and interaction between the architecture team and other disciplines as well as with the people involved in the design process. At the same time, it is also the expression of architectural expertise in the construction phase (Figure 6). Moving towards a direction of objectification of design and architecture driven away from the paternalism of the architect. Creating an ontology in the design, can help improve individual parts, or add new ones, placing them in a broader, shared framework.

In conclusion, the role of architecture and the architect is changing under the pressure of social and economic changes, along with the proliferation of new technologies and the internet. This paper tries to shift the attention towards the reestablishment of participatory processes that deal with the connection between the city and its users.

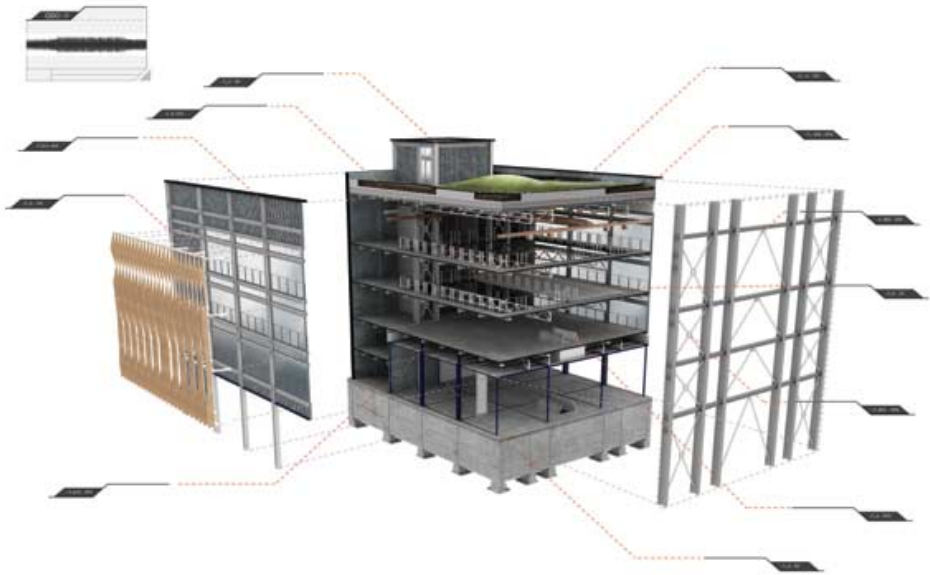

Figure 6. The ontology of the construction

References

- [1] R.A. Block, Models of Psychological Time, in: *Cognitive models of psychological time*, R.A. Block, ed., Lawrence Erlbaum Associates, NJ, 1990, pp. 1-35.
- [2] A. Burke and T. Tierney, eds., *Network practices: new strategies in architecture and design*, Princeton Architectural Press, New York, 2007.
- [3] M. DeLanda, Space: Extensive and Intensive, Actual and Virtual, in: *Deleuze and Space*, I. Buchanan and G. Lambert, eds., University of Toronto Press, 2005.
- [4] A. Kuhn, *The Logic of Social Systems* (Trans. Originally published: Jossey-Bass, San Francisco, 1974.
- [5] L. Pierre, *Becoming Virtual: Reality in the Digital Age* (Trans. Originally published: Perseus Books, 1998.
- [6] L. von Bertalanffy, *General System Theory: Foundations, Developments, Applications* (Trans. Originally published: Braziller, New York, 1968.
- [7] F. von Borries, S.P. Walz, and M. Böttger, eds., *Space time play : computer games, architecture and urbanism : the next level*, Birkhauser, 2007.
- [8] M. William, *E-topia* (Trans. Originally published: MIT Press, 1999.

Spatiality of Athens' digital footprint: Limitations and opportunities for “intelligent” urban planning

Iro BALA^{a,1} and Eirini MOSCHOUTI^a

^a*MSc Urban & Regional Planning, National Technical University of Athens*

Abstract. The existence of a new digital layer added to urban reality is a common place for various approaches which discuss the evolution of the “digital city” concept, as well as the emersion of intelligent environments. Considering that every city embeds new technologies with a unique- either strictly constructed or even unplanned- manner, one could actually presume that the penetration of ICT reveals multileveled opportunities as well as limitations for urban planning in each case. Focusing on the city of Athens as a case study of an unplanned version of a digital city, we examine its spatiality through its digital footprint and discuss the potential of new planning practices driven by the availability of urban data.

Keywords. digital cities, digital footprint, urban planning

Introduction

At the time being, academic and policy concepts are dealing with the dynamics of ICT regarding the city development as well as city perception. Among them, the evolution of the digital city from the “introduction of city metaphors” [1] to the establishment of contemporary informational, intelligent landscapes [2] could be characterized as an ongoing procedure of conceptualization and public understanding, which is highly differentiated geographically (and at every city case).

What is supported is that the “digital footprint” of the contemporary city seems to result either from innovative, coherent ICT policies, coordinated by formal initiatives of public and private sector, or emerge as a patchwork of individual -as well as collective- action in digital space regarding the city [3]. In this context, various types of interaction between groups, individuals and ICT use in everyday life in the city could momentarily reveal a reflection of the city in digital space.

The above assumption has driven a research regarding the dynamics of the informal way in which the digital space of a city is constantly being shaped, as a product of different means of interaction. The city of Athens is used as a case study, where the everyday use of ICT for different purposes and in different places within the city reveals a first set of challenges both for the city and urban planning. Assuming that the spatiality of choices illustrated digitally in urban space shed light on opportunities and limitations, we examine the potential for the transformation of user's urban perception along with urban planning.

¹ Corresponding Author: irobala@hotmail.com

1. Towards a “Digitalized” Urban Experience and Planning

1.1. Transformative effects regarding urban experience

From the city as a “construction in space” to the city’s multilevel representation in cyberspace, we are nowadays motivated to assume that the city’s sense, with regards to urban experiences, has been affected more than ever before. The constant advances in technology, the digital evolution of Web 2.0 and social networking seem to cause a shift in urban life within digital environments or informational landscapes, where individuals and groups voluntarily participate and interact, receiving and transmitting information about localities. The shift towards a “digitalized” urban experience is globally intensified in highly developed cities, adding meaning and value to the existing notion of collective experience, easily obtained or accessed through urban information/data-using different kinds of representations for the urban dweller/user. [3]

Approaching the transformative effect of ICT, in the context of a broad array of network embedded technologies –or the so called urban computing [4]- on both individual and collective urban experience of the user, together with an alteration in his behavioral patterns, we acknowledge that little or zero is the effect on physical form of the city. Wachter argues that “the spatial repercussions of virtual relations inevitably involve the mediation of individuals, organizations and social practices. It is, in fact, the use – not the material presence- of networks and their associated services that exert spatial effect” [4]. The central argument here is that the digital space adds another dimension to the physical space. Yet, this seems to be a reciprocal process, given that the advent of ICT in physical space (especially location- based services and local positioning systems) adds another spatial dimension to virtual technologies. [3]

According to Greenfield and Slavin [4], in the era of urban computing, the city’s users are no longer bound to passively experience the territory; they move around but they have been empowered to inscribe their subjectivities in the city itself. Those subjectivities can be linked with spaces and responded to by those who are to come after. Locations have their digital footprint in cyberspace- through “digital traces”, such as “tagging” or “checking in” by those who visit them, or even through digital pictures, comments and impressions- so much that it intervenes with and sometimes defines the way we experience the physical space. [3] This process –which is described by the term “read/write urbanism” [4] – is considered to cause the loss of the immediacy together with the distortion of user’s subjectivity on space. The physical space gets imprinted on the digital space and the user can constantly and repeatedly experience it, through the physical experience of other users, or through his computing device, without actually being in it. [3]

1.2. Reforming the Urban Perception: Data and Augmented Reality

Probably, the most current aspect of the shifting of the urban experience through the digital space refers to the concept of Augmented Reality (AR). The use of AR adds a new perspective to the data-enabled experience of the urban context, due to the merging of the virtual and the actual realm. AR applications, within the urban environment and the public space, indicate points of interest or navigation routes within the city just by “scanning” them by means of a computing device, integrating different types of digital projected information from various sources to the physical object/view. The urban environment, as an aggregate of both the physical space and part of the

virtual space, blurs the limits between the virtual and the actual and it is perceived as a continuity or gradient. [5].

The physical space is structured and is meaningful to the dweller in terms of the relationship established in a variety of infrastructures, of action and interpretation [7]. Yet this spatial relationship forms the individual and collective experience within the urban context. The ever-growing array of embedded networked systems and practices is a moving target with constantly emerging trends, tools and platforms. Participation is often unnoticeable, membership is mandated and in most of the cases effective refusal is impossible [8]. Within this framework, the urban environment is enriched with a new established “digital” layer, followed by the transformation or- as alleged here - “digitalization” of the ways that the dweller experiences the urban environment.

1.3. Urban(e-)planning or intelligent urban planning?

The conceptualization of “intelligent” urban planning practices could be seen in the context described as an immediate outcome of the above transformations. Two indicative approaches are discussed in order to track the central aspects of the potential role of urban planning in the digital era.

Research for the role of urban planning in “smart” or “intelligent” city concepts and projects indicates that urban planning can be an integral part of a layer between the physical space and the digital spatiality over the city [9]. Including institutions, planning and governance, this layer coordinates the two-way processes between digital and physical space, contributing into the creation of intelligent environments. Consequently, urban planning can be seen as a significant factor for the provision of new services and the promotion of various forms of intelligence (artificial, human etc) [9]

From another perspective, the “e-planning paradigm” is often discussed not only as a provision of better planning in terms of efficiency in urban management through ICT use, but also as an opportunity for the reform of planning procedures. According to this, a more inventive, creative and socially inclusive planning could be possible, given that a key component is substantial change in the nature of planning processes and methods. Including various e-tools, (such as data modeling, virtual reality technologies, internet interactive mapping, social media tools etc.) data collection and public participation are considered as core-transformative procedures within the creation of “e-planning systems” [10].

Each approach reveals an emerging, differentiated role of urban planning, despite the fact that its implementation depends on a broad array of factors (existent planning system, diffusion of ICT). As a result, specific opportunities and limitations for urban planning seem to be outlined while we approach every city-case, fact which is taken into consideration regarding the research in the case of Athens.

2. Spatiality of Athens' Digital Footprint: An approach through different Spatial Visualizations

2.1. The case of Athens: Research Context

The omnipresence and the implications of digital technologies within the urban context establish a new (digital) layer. Consequently, we recognize the current “digitalized”

urban experience as the “digital traces”, left behind by the use of digital technologies. Through the processing of the elements that consist “digital traces” the digital layer can be spatially reflected, similarly to the digital footprint of the city. In this context, the issue of the digital inclusion rises as a challenge, concerning the study of the Athenian case.

Therefore, in terms of digital inclusion, the metropolitan region of Athens seems to present a gradual progress, compared to other Greek regions, although it is highlighted that this progress is heavily dependent on education and age factors [1, 11]. At the same time and at a national level, the divergence from the European average for digital literacy and skills is getting wider [11].

In this framework of challenges, a focus on the case of Athens enables insight into the everyday interaction among the digital technology, the urban dweller/user and the city. This is achieved through an indirect approach of the components that synthesize the urban experience, thus the digital footprint of the city- in digital space for the urban dweller and the ICT user. To define the spatiality of what we assume as the digital footprint in the case of Athens, we employ different spatial visualizations, encompassing the social network realm, mobile applications (city apps) with direct spatial reference to the city of Athens and a web survey among internet users who live in Athens.

2.2. Visualization A: Spatiality of Athens' digital footprint within the social network realm

Based on the concept of “read/write urbanism” analyzed above, a spatial visualization of Athens' digital footprint can be derived from check-ins or tagging of physical spaces within the digital realm. The tagging of Athenian locations using the data from Foursquare [Figure 1] highlights the major leisure (Gazi, Monastiraki Panormou), commerce (Ermou Str., Panepistimiou Str., Stadiou Str., Akadimias Str., The Mall Athens) and business poles (Kifissias Str., Sigrou Str.) or axes, situated in the region of Athens. Additionally, public places, cultural or touristic locations, academic facilities and transportation terminals, are illustrated with a smaller intensity. On the other hand, this process indicates parts of the city, which have zero or little digital footprint. We could draw conclusions about the reasons that the certain spaces have strong spatial representation but it remains to investigate them further in depth.

An approach, in order to extract more direct conclusions is drawn from the locations, which the web-survey participants have recently “tag” (Figure 2). The spatiality of the digital footprint of Athens –in this case- is also proven to be solid with almost none variation. In this framework, we acknowledge the spatiality of the digital footprint in the case of Athens, as a fragmented representation of the individual and collective urban experience, which the urban dweller chooses to share within the digital realm. The representation of the “digitalized” urban experience is primarily associated with spaces related to lifestyle and therefore market-driven initiatives.

However to better understand the spatiality of this new type of urban experience- the connection between the spatial reference and the concerning type of activity should be considered. This is achieved by analyzing groups and pages with spatial reference to Athens across Facebook and Twitter.

We observe that the majority of the activities, especially Leisure, Business, Education, Collectivities, Sports and Culture, have spatial reference within the digital

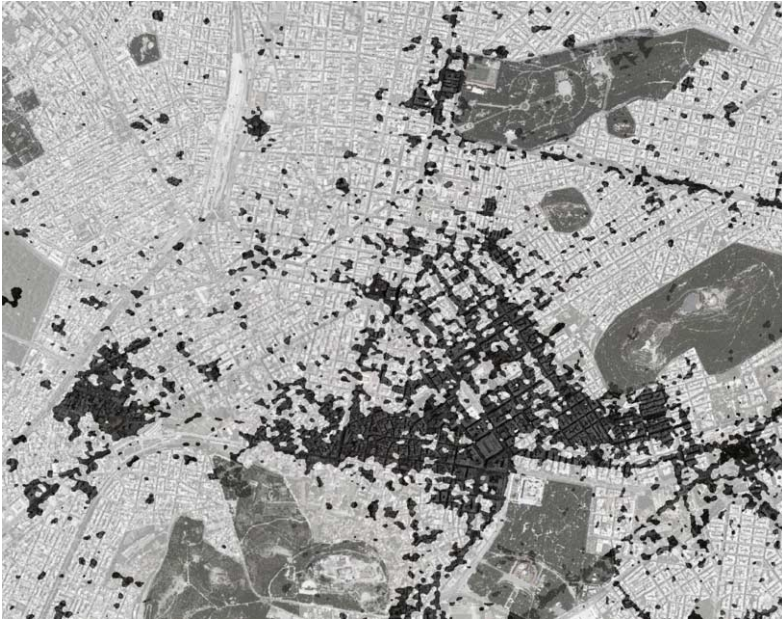

Figure 1. Foursquare: Map of 5.000.000 check-ins, visualization of the center of Athens

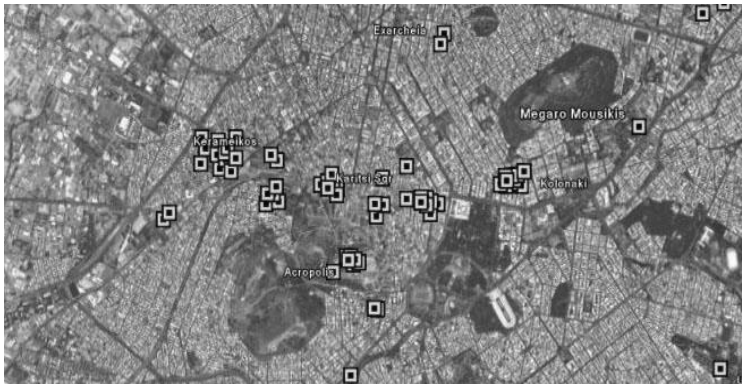

Figure 2. Athens city center: places, where the participants of the web-survey have recently checked in.

space (Figure 3, black line). However, when measuring the “popularity” of the activity we detect the dominance of Business, which mainly relates to leisure or commerce, and Leisure (Figure 3, gray line).

2.3. Visualization B: Spatiality of Athens' digital footprint through mobile applications

On the premises that mobile applications appear to be a more accessible and portable way for city dwellers and visitors to access and share information in real time, a secondary approach towards the identification of spatiality of the digital footprint in the case of Athens- in terms of linking the activity with its spatial reference within the digital realm- is attempted through mobile applications. The latter exemplify a direct reference to the city of Athens. There are three areas in which the mobile applications

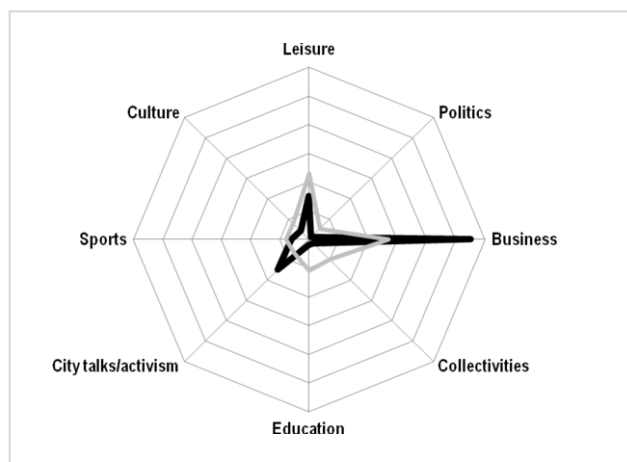

Figure 3. Groups' and pages' distribution with direct reference to Athens across Facebook (black line) and popularity of the specific thematic areas (gray line)

are aggregated, referring to the connection between the spatial distribution and the concerning activity: (a) tourism, in terms of city guides or city maps and thematic city walks, which mainly refer to the city center (b) business in terms of location's designation within the city, and (c) transport / navigation.

At this point, it should be noted that the above approaches reveal trends directly dependent upon the nature of the tool and the way it is used. However, the trends indicate spatial distribution which bares elements within the context of attractiveness and branding approaches, which penetrate into several aspects of the urban experience. The spatial distribution, which is presented through the certain experimental methods, forms a fragmented digital footprint of the city in the case of Athens. This process, due to the significant participation of marketing tools (associated with leisure, business etc.), leaves outside of the visualization several parts of the city. In this context, we conclude, that the digital footprint, a concept that seems to have a non-spatial character, presents strong distribution within the urban environment.

2.4. Visualization C: The "digitized" urban experience of the Athenian dweller

Seeking common ground between the urban experience and its mutations caused from the embedment of ICT in everyday life, we encounter a variety of tendencies and limitations, as regards the penetration of new digital services employed to satisfy urban needs. In an attempt to simulate the process that can be described as the "digitalized" urban experience, we examine main aspects of city's function within the web space, viewed from the dweller's side.

Firstly, research conducted among users and their everyday habits indicate an uneven distribution of web use within the urban fabric. Internet access from public and educational spaces, along with the typical places of work and residence, can be related to a gradual spread of internet use in open spaces, often reaching the 50% of the cases. The differentiation on the concept that the digital footprint excludes places within the city, is related to the concerning activity. Within this context, the everyday use of internet is highly related to communication, social networking, and working purposes, while the use of the internet is also frequent for transport, locating new places and

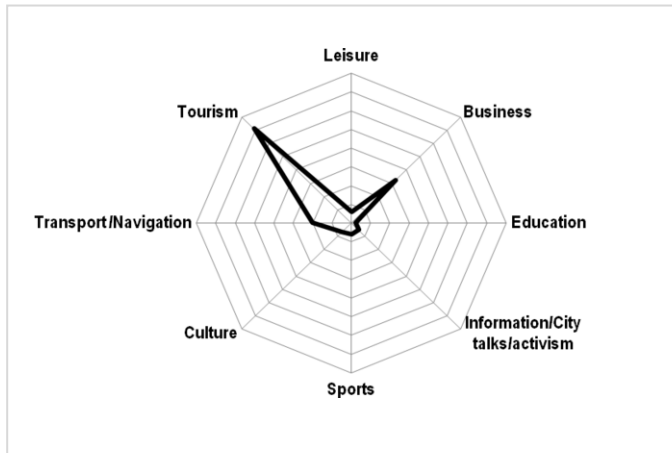

Figure 4. Mobile applications' (IOS) distribution with direct reference to Athens –across specific thematic areas

navigation reasons. Using a variety of online navigation tools and city-guides, we observe a frequent access to digital space for leisure, a fact already confirmed [Figure 1, 2, 3].

The use of ICT for working purposes yet concerns everyday life in the city, as the use of internet is mainly related to communication and information purposes and less to advanced applications of ICT in business activities (networking, promotion, marketing practices, commerce etc.)

Focusing on urban governance and the more specific ways in which individuals perceive the city as a digital community, we observe a better understanding of the concept and use of e-government applications. Experiencing limited participation and city-related initiatives via digital space, social networks and online journalism constitute the main resources of information and discussion about the city.

In the case of Athens, the relationship between the urban environment, new technologies and the human interaction is yet to be defined. The penetration of the ICT within the city's function is achieved in a conventional manner. As a conclusion, the mutations towards a "digitalized" individual and collective urban experience is a process in progress, as a significant number of aspects of everyday life in the city remain a matter of individual choice for the urban dweller.

3. Limitations and Opportunities Regarding Urban Planning

The previous notes regarding the spatiality of Athens' digital footprint can be seen as a context of challenges, in which urban planning could have a major role in terms of deriving data, trends and various types of information about urban space, as well as its digital layer.

The main argument here is that location-based information- traced in multiple types- can be derived from the user/urban dweller in order to collect and maintain data, identifying urban flows and networks. This procedure seems to happen in a spontaneous way, as individuals and groups are prone to map their places of work, living and leisure, adding with this way value and meaning to places digitally. Even if

it is not yet a product of standardization, it seems that interactive mapping within the social network realm can offer dynamic, digital representations of alternative “land uses”. In other words, the above visualizations can be transformed into useful tools of communication between urban dweller and the planning process, which could be rendered open, receiving a great deal of information flows.

Apart from the value of information which could be derived, a wide field of research is identified with the possibility of the diffusion of urban information. While an increased interest for “city talks” is observed, urban planning can keep track of place marketing and place branding procedures that are actually happening informally. In this way, public involvement and further interaction between experts and urban dwellers could be possible, in terms of constant feedback and collaboration.

From the other hand, a significant limitation in order to seize the above opportunities is the existence of digital divide between groups and places. As it was previously noticed, disparities which concern physical as well as digital space seem to be reproduced, leaving open issues regarding digital inclusion. Moreover, already limited availability and access to public/urban data create a low potential for a better understanding of urban planning as well as participatory procedures. In this, it should be also added the observation of a low interest and uncertainty regarding formal forms of public participation via internet.

Finally, the process of “raw data” and the linking of digital and physical space might be proved a laborious procedure of verification and identification, since there is a need of valid sources of information among users and groups. In the same context, abundance of information regarding certain urban issues compared to other less popular –but also important for urban planning– issues results to a severe lack of representativeness which concerns people and places. As a result, the existence of over-promoted places and activities as well as “blind spots” of physical space, often create a distorted image in the digital space, making certain sources of information still rare and invisible.

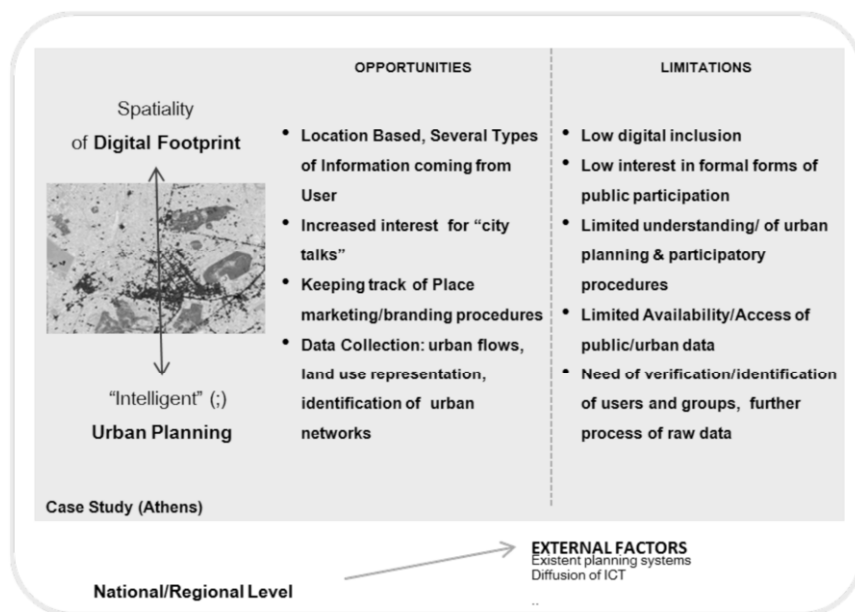

Figure 5. Opportunities and Limitations for “Intelligent” Urban Planning

4. Conclusions and Future Research

The spatiality of a city's digital footprint, in the way it is so far approached, seems able to contribute to a better understanding and thus planning of the contemporary city and its digital layer. In the case study, the various challenges- outlined in the form of opportunities and limitations- highlight for the spatiality of Athens' digital footprint the reproduction of existent relationships, densities and disparities in urban space.

Further research in the various linkages between the physical and digital space in Athens could guide to a consistent methodology of a "tactical" urbanism, where opportunities and limitations would be placed equally, contributing to gradual transformation of urban planning procedures.

The reinforcement and encouragement of information flows among formal and informal spaces, which provide data of various type and scale, are considered core objectives concerning tactical urban strategies. The elaboration of linkages among social networking, voluntary mapping and formal e-planning platforms would create and enhance information flows, encouraging and maintaining participation. In addition, the conception and establishment of adaptable mechanisms (new software, applications, platforms), able to filter, process, verify and validate information and raw data, could be orientated to statistic and spatial analysis, in terms of a targeted geocoding of information. In this context, urban planning could evolve towards a more intelligent discourse, under the basic conditions of augmented digital inclusion and creative restructure of planning procedures.

References

- [1] T. Ishida, K. Isbister, *Digital Cities: Experiences, Technologies and Future Perspectives*, Springer-Verlag, Heidelberg, 2000
- [2] L. Hui-Ting, C. Mao-Lin, From urban landscape to information landscape: Digital Tainan as an example, *Automation in Construction*, 5 (12) (2003), 473-480.
- [3] I. Bala I., E. Moschouti, "Approaching the contemporary digital dimension of the city: Notes and challenges regarding Athens' digital image". In the *Proceedings of the International Conference on "Changing Cities"*, Skiathos, Greece, 2013 (forthcoming).
- [4] A. Greenfield , M. Shepard, *Situated Technologies Pamphlet 1: Urban Computing and its Discontents*, The Architectural League of New York , New York, 2007
- [5] S. Wachter, *The digital city: challenges for the future* (translated by Oliver Waine), *Metropolitiques*, <http://www.metropolitiques.eu/The-digital-city-challenges-for.html>, 2012
- [6] P. Barrie, A. Komninos, O. Mandtychenko, A Pervasive gesture-driven augmented reality prototype using wireless sensor body area networks. In the *Proceedings of the 6th International Conference on Mobile Technology, Application & Systems*, Nice, France (2009),1-4
- [7] P. Dourish, Meaning and Practice in Encounters with Urban Space: Notes for presentation at the *Urban Talk workshop*, Intel Research, Berkeley, USA, 2004
- [8] C. Nold, R. Van Kranenburg, *Situated Technologies Pamphlets 8: The Internet of People for a Post-Oil World*, The Architectural League of New York, New York, 2011
- [9] N. Komninos, Intelligent cities: towards interactive and global innovation environments. *Journal of Innovation and Regional Development* 4 (1) (2009), 337-355.
- [10] C.N.Silva, The E-Planning Paradigm- Theory, Methods and Tools: An overview, *Handbook of research on E-Planning- ICts for Urban Development and Monitoring*, IGI Global, Hershey PA, 2010, 1-14
- [11] *Observatory for Digital Greece, Digital Literacy in Greece and EU27 2007-2010*, Observatory for Digital Greece, Athens, 2011.

Non Linearity - Text/Cyberspace/City

Ioanna CHEINOPOROU

The Bartlett School of Architecture, UCL

Abstract. Having as a fundamental skeleton the notion of the non linearity, this study will investigate to what extent potential connections might exist between a written text, the cyberspace and the city. Starting by the exploration of the non linearity as met in the reading of a text, this kind of structure will gradually intersect with the non linearity of the 'reading' or the concept of cyberspace and later it will be projected onto the 'reading' of the real city. Acknowledging the data as the invisible 'material' for the perception of an notion, an object or a condition, the non linearity as a distributed and decentralized networking structure is attributed to the crossbreed of the physical and virtual version of space as met in the three aspects of investigation, that is the text, the cyberspace and the city if considered as sets of data. In the era of the cell phone being the digital extension of the individual - functioning as a 'bridge' between the real space and the virtual, this essay will, finally, discuss how this new reality might affect the 'reading' and 'rewriting' of the city or how the city is perceived by the human who is currently able to manipulate both sorts of spaces at the same time.

Keywords. Non linearity, cyberspace, text, psychogeography, urbanism

Introduction: Non Linearity

Non linearity as a structural and organizational system could be defined through a wide range of different fields. Non linearity might be associated, among others, to the non-Euclidean geometries, the Einsteinian universe, the Quantum Physics, the non linear perception of a work of art or even a cybernetic network. What lies underneath the notion of the non linearity is the *indeterminacy* and *discontinuity* [1]. What characterizes a non linear structure is the multiple polarities among its particles/elements and the non existence of an objective centre, the infinite possibilities of it being perceived depending on the point of view and, finally, the fact that it functions within a specific field of relations or else a relativity frame [2].

According to the Einsteinian universe approach, relativity means 'the infinite variability of experience as well as the infinite multiplication of possible ways of measuring things and viewing their position'.¹ This non Euclidean space, which is considered as spatiotemporal, is a space 'transformed' in itself not because it constantly changes in its terms, but because its form is up to the observer's point of view. Consequently, without any doubt, both Einsteinian universe and quantum physics underline that this world they suggest even though it might seem chaotic, is governed by solid and perfectly regulated rules [3]. This chaotic system is an infinite network of nodes and linkages which interact. Even though there is not an objective centre, the point of view of the observer will set the appropriate node as one.

Umberto Eco, in his study '*The Open Work*', encounters this relativity and Einsteinian approach of the non linear or chaotic structure in the perception and function of a work of art. He recognizes within a work of art, an *openness* which expresses the unexpected reading of the network of data which the author or the artist provides, by every different individual observer. The work of art, for Umberto Eco, is a

non linear constellation of data which forms a message solidly structured but liquidly transferred. This multiplicity of possible readings is due to the fact that the field of knowledge of every different reader and the metaphorical point of view are different. This openness, he states, might potentially exist in every work of art because it constitutes a wide network of nodes and linkages of information and implications but it could be also literally observed in an artistic object if the creator wants, intentionally, to express this non linearity of perception of the givens.

More literally, the non linearity and the ‘chaotic’ distributed networking is the underlying structure of the Hyperspace and later of the World Wide Web. According to Silvio Gaggi, in his essay ‘*Hypertexts and Hyperrealities*’ [4], ‘*the postmodern hyperspace is so ubiquitous that it cannot be escaped; one is always in it, disoriented by its organization and by the “logic of the simulacrum.”*’ World Wide Web, as it will be further analyzed, could be said that it represents the more real or tangible version of the Einsteinian universe that the humans can manage and perceive.

To conclude, non linearity will constitute during this study, at first, the organizational structure tying together the network which underlies a text, which will be examined both as a finite written object and as an accumulation of data particles, and the hypertext which is the evident manifestation of the previously hidden non linear structure of information of the text. Thereafter, the non linearity will be analyzed in more spatial terms by the insertion of the notion of the cyberspace which hosts the hypertext and which tends to constitute the digital version of the city as it will be further discussed. The study, finally, suggests the emergence and the perception of the non linear relationship of the city and the information and it analyses methods through which this non linearity could be attributed to the urban transformation and mutation. Even though this research is spinally developed through the different fields of investigation (text, hypertext, cyberspace, city), it constantly highlights their in between relations and folds the argument in itself. Non linearity is considered as a rather interesting organizational structure since it presents a conceptual strategy and a highly spatial and topological configuration at the same time. It can be examined as the medium to connect disembodied elements to a tangible formation. This oscillation between the elaboration of the immaterial classification of components (data) towards a material form traverses the whole argument and seems to be the most crucial property of the non linear networking.

1. The text as a non linear network

Text, in the frames of this study, is perceived as a structured and organized manipulation of language. It constitutes an object which is seemingly linearly developed but it presents an underlying network of inner relations, data, signs and knowledge. It will be examined as another designing structure that relies on a dataset which is fundamentally constructed by the writer-designer but it is re-constructed by the reader under a wide spectrum of possibilities and non linear linkages of its data network.

In literary theory, a text is any object that can be “read,” whether this object is a work of literature, a street sign, an arrangement of buildings on a city block, or styles of clothing. It is a coherent set of signs that transmits some kind of informative message. This set of symbols is considered in terms of the informative message’s content, rather than in terms of its physical form or the medium in which it is represented [5]. It seems

rather interesting the fact that we could comprehend any formal configuration as a text or a message and to build a design method according to this ‘reading’.

More specifically, the written text, an organized accumulation of language elements, situates the words in a certain arrangement in order to produce a message. Hence, language is the tool or the brick for this arrangement to function. Language, according to cognitive linguists such as Lakoff and Johnson, is a wide container of metaphors [data] which function as a solid mechanism or tool for the expression of abstract notions [6]. This abstraction already implicates that the system which governs a text might not be linear as the occidental way of writing initially indicates. Even though a text is read from the left to the right, in occidental cultures, the absorption of the underlying semantic data takes place in a non linear manner. Umberto Eco, in his study the ‘Open Work’ has proposed that a text, as any other piece of art, might be constructed in way that either its structure is intentionally non linear referring to the provision of data or potentially any text is considered as an open network of informational nodes which the reader should translate in his/her own terms, according to their cultural, theoretical, intellectual and cognitive background. We could identify in Eco’s suggestion the non linear manipulation of the disembodied material, information, towards a personal formation of knowledge. This immaterial component which exists in an infinite amount and provides an infinite catalogue of combinatorial possibilities will be delimited to the finite reconstruction by the user in a solid classification of the informational nodes.

Furthermore, in a written text, even though the virtual space that might be described by the author is situated within the Cartesian frame of spatial perception, the textual units which articulate the text have no Cartesian coordinates . They function as links and nodes creating a network of data. This network is considered as a self-contained system, since a text, perceived as a message from the author to the reader, should imply all the knowledge needed in order to be efficiently ‘translated’ [7]. It is interesting to illustrate the topological space which the inner relations of the text form in comparison to the topographical physical space that might be described.

The fact that it is the reader who plays such a crucial role in the final outcome of the text, implies that he ends up being a co-writer as it is the interpretation of the message of the writer that will determine the final form of the text. This fact directly attributes a liquefied form to the written language, if it could be visualized, as it is constantly changing, is emergent and metaphorically generic since it is always interdependent to the unknown reader’s point of view.

From another point of view, and apart from the literally theory which accepts as a text ‘any object that can be “read”, the definition of the written language is ‘the representation of a language by means of a writing system’ [8]. A writing system, in its turn, is founded on certain syntactic structures. These syntactic structures, as encountered by Noam Chomsky and other linguists under the context of Structuralism, evoke a non linear dissemination of the language, which deconstructs the object-text into its grammatical elements and into a generative skeleton. Noam Chomsky perceives language ‘as a set of finite or infinite sentences, each finite in length and constructed out of a finite set of elements.’ [9] He argues that these elements, or else points with a syntactical identity, constitute a universe of combinatory possibilities but only if specific rules are followed, a sentence would be produced. These rules are becoming obvious if a recursive analysis of the syntactical nodes takes place. A derivation which is a sequence of replacement of the syntactical nodes by syntactical points produces a branching structure of the elements of the text. It is necessary to be noted that this non

linear approach of language separates the grammatically correct sentence from the meaningful sentence, as they are the parts of speech that are combined in order the speech to be formed and later they are replaced by the vocabulary.

To conclude, this non linear dissemination of the text expresses the written language as a decentralized network of entities and a topological arrangement emerges. We can observe already a very fruitful field that allows a practical perception of this non linearity and it could be considered as a manual or guide towards a designing procedure or method of our manipulation of the immaterial brick as it will be later discussed. It is not only this generative branching structure that creates a spatial reconstruction of the speech but also the fact that in this branching system there are elements that function as an origin of a regeneration and elements less crucial but necessary as they modify the final outcome of the parse tree [10]. Once again, we can identify a hidden topology of nodes (parts of speech), linkages (combinatory rules) and points (words) which form a network.

2. Non Linearity in Generative Speech Creation

The perception of the written language as a universe of possible combinations of the elements according to their syntactical identity, as Noam Chomsky suggests, could not be more clearly allegorized in Jorge Luis Borges' short story the 'LIBRARY OF BABEL' in 1941 [11]. However, instead of applying a sort of universe spatiality on the written language, Borges, reversely, conceived of the universe itself as a vast library. In his imaginary universe the elements are not syntactical particles but the words themselves. This infinite library is built out of cells that host all the possible words in every possible language. The inhabitants of this universe believe that if every possible combination among the words takes place, then every coherent book ever written, or that might ever be written, and every possible permutation or slightly erroneous version of every one of those books potentially can emerge.

Italo Calvino, in his turn, in his novel 'ON A WINTER'S NIGHT TRAVELER' , a writer, encounters a woman who refuses to read his novels, but instead feeds them as data into a statistical program as she wants to save time[12]

This novel could be considered as a preamble to the non linear reading or writing of a text and as the underlying theoretical predecessor of the creation of the Hypertext as a non Cartesian form of written language. This woman encounters the text as a set of data and lets a programmed computer to re-write the text by producing accumulations of the more frequently used words. The linear structure of the text is transformed into accumulations of data with common properties.

Taking into consideration the above metaphors, we could observe that the text starts to represent an arrangement of data that is revealed or created by an 'early' algorithmic approach. A great topological relation between language and space might arise and endure this non linear chaotic classification of data that can be orthologically form meaningful entities. Once again notions as point (word) and linkage (word connections within a network) can be attributed to the written language. The more important aspect is the spatiality that emerges and the systemical elaboration of the given data regardless of the field of investigation. These analogies reinforce the argument towards the condition of the reality as a hidden non linear configuration of information, support the conceptual notion of the network and thus create the context of the rest of the study which speculates the city as a cross reference between the virtual

and actual reality which provides a new environment for the user to interact with and to translate.

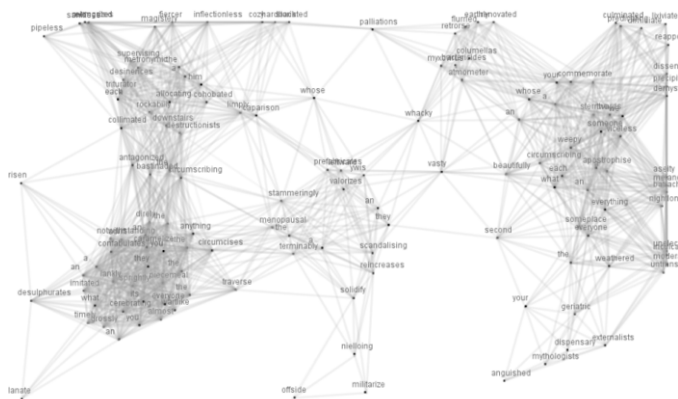

Figure 1. Non linear classification of data, Ioanna Cheinoporou

3. Hypertext: a non linear text

After the dissemination of the written language in an underlying vast network of translations, syntactical nodes and later words, the text is going to constitute itself the node of a wider system. Hypertext is investigated firstly as a form or a catalogue of texts that is non linearly navigated and secondly more literally, as a non linear structure or ‘architecture’ of text. More specifically, hypertext is defined as ‘text displayed on a computer display or other electronic device with references (hyperlinks) to other text that the reader can immediately access, usually by a mouse click, keypress sequence or by touching the screen [13]. Hypertext is an infinite database of text which interconnect in between them. The space that hosts this intangible library is well described by Silvio Gaggi, as a undetermined landscape where the subject cannot orient himself and has to make personal decisions in order to form this chaotic space according to the multiple choices that it provides. Potentially, all the texts connect to each other creating a network of knowledge. This vast meta-library reminds of the Borges’ universe seen as an infinite library.

Furthermore, this hyper textual reading sets the subject as responsible for the final formulation of this undetermined space and the arrangement of data not only metaphorically but also literally as the reader can add information on the network, comment or create new links. The text is not functioning linearly from the author to the writer but as a distributed network of communication between users, authors and texts. This system lacks of a centre, a path or a guidance by the author since it is a self contained network manipulated by the user. The user tries to decodify the message and to attribute meaning to this constellation of data.

From another point of view, hypertext can represent also the format of a digital text. This kind of text is created digitally in a virtual space and reminds more of a textual mapping rather than a written text. This configuration of data which is intentionally fragmented by the author suggests a three dimensional arrangement of the givens of the text but also provides numerous linkages to any contextual elements necessary to the reader to perceive the text. The reader manipulates this non linear map

of information trying to detect the clues, to cross-reference and to produce a potential meaning. The text is transformed into a topological space of nodes and linkages which the subject should navigate himself around.

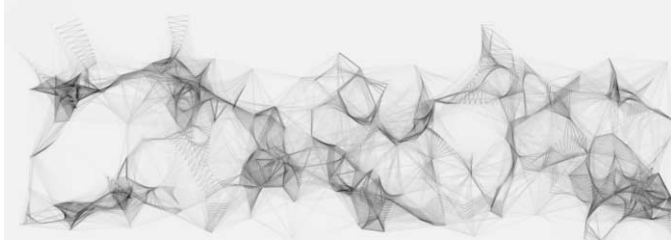

Figure 2. Non linear structure, Ioanna Cheinoporou

4. Hypertext: The underlying concept of the spatiality of the World Wide Web

The notion of Hypertext is another approach to the classification of data in a non linear basis. Apart from text, hypertext is sometimes used to describe tables, images and other presentational content forms with hyperlinks. Hypertext is the underlying concept defining the structure of the World Wide Web. It enables an easy-to-use and flexible connection and sharing of information over the Internet. ”

In other words, hypertext describes the relative relations among data and knowledge that take place within the chaotic ‘cyberspace’. Topologically, the cyberspace is an undetermined non Cartesian arrangement where the notion of distance could be ‘measured’ by the speed of downloading and the movement is taking place by jumps rather than by linear gradual ‘walking’. In this infinite place, the subject meets nodes that lead to other nodes through linkages [14]. These nodes are texts, not only written, but any object that can be ‘read’, as previously has been noted. Eventually, spatial, cultural and textual properties can be recognized within the virtual space of the World Wide Web. Marie Laure Ryan imagines the internet connections as ‘the Rabbit Holes that allow us to slip out of physical reality, and to enter a data Wonderland where everything can undergo unlimited metamorphoses, because everything is made of bits whose value can change with every clock cycle of the machine.’ [15]

At the same time ‘cyberspace’, according to Lev Manovich, is a metaphor that spatialises what happens in computers distributed around the world” [16]. In current usage the term cyberspace refers to the global network of interdependent information technology infrastructures, telecommunications networks and computer processing systems in which online communication takes place.

Even if the cyberspace is the host area of the hypertext and constitutes a network of a wide range of data there are certain analogies to the metaphorical and literal non linearity as met in a written text. At the same time, it is the fact that both the universe of a text and the universe of data of the cyberspace are, as it has been already discussed, a non linear network that the subject reads and forms in its own subjective way and his personal point of view. Another aspect that intensifies the textual characteristics of the WWW is the fact that this chaotic data network is navigated by the individual by the insertion of a word or phrase in a search engine. A wandering within the discontinuous topological landscape of the Internet begins by the point of view –as the relativistic Einsteinian theory would suggest- that the inserted word determines and the evolving form this unknown place is being produced according to

the search engines classification of results relevant to the inserted phrase and reader's choices concerning the websites that he chooses to visit.

5. Cyberspace as a psychogeographical landscape/ flaneurie

Recently, correspondence has been drawn between this variability of manipulation of the hypertext and the cyberspace and the term 'psychogeography' which had been primarily established by the Situationists in the 1950s. Psychogeography in its historical and contemporary versions attempts to find alternative narratives to the 'official ones', according to Hay Duncan.

The psychogeographical wandering around the city by the Situationists suggests an alternative reading and redraws the map according to the individual decisions and the individual outcome. According to Joseph Hart it is just about anything that takes pedestrians off their predictable paths and jolts them into a new awareness of the urban landscape. This approach of the exploration and perception of the geography and the urban landscape was developed under the context of combating 'the false consciousness that Debord argued produces both alienation and impoverished thought under capitalism called for the construction of a new, liberatory urban space' [17]. This movement of the Situationists intended to create a new urban design, to reassemble the pieces of the city system, to append new meanings on this urban text and eventually was opposed to the functional Euclidean values in architecture.

The official map of the city is rejected and the urban landscape is transformed into a labyrinthine universe that the user should translate in his own terms. The 'dérive' is the method that the psychogeographical exploration of a city suggests. It is the unorthodox or unpredictable drifting within the city net without the help of any official navigation means, which provides a new mapping of the urban space according both to the user's choices but also the possible 'algorithmic' instructions which guide the 'flaneur'. It leads to a non linear redrawing of the city, if we perceive as linear any official navigating method that provides the shortest path to a destination.

The technique of the 'dérive', as proposed by the Situationists, might be paralleled to the reader's drift through cyberspace. The notion of psychogeography in the era of the World Wide Web and of the hypertext is redefined. It can now be located in virtual space. Cyberspace, according to Marie Laure Ryan's study, is experienced as much a collection of places to inhabit, as an open space to be explored though aimless flânerie [18]. The internet is thus an ideal medium for navigable spaces to perpetuate the continuous drift. The internet and consequently the cyberspace and the hypertext function as those unpredictable but systemic rules that the original psychogeographical procedures suggested. The reader can be recognized as the 'flaneur' that Charles Baudelaire has described, within the chaotic cyberspace. This new cyber- flaneur tries to find his way through data that are chaotic but systemically organized both by the search word that he/she has set but also by the relativity rules that the search engine follows in order to offer the more appropriate data needed. This strolling is nothing less than a non linear reading of data in an unmapped topological rather than topographical place that after the reconstruction by the reader, creates organized information and knowledge.

6. The phychogeographical Landscape as a ‘text’ to be read

If the real city or the urban net are considered as the ‘text’ to be read by the individual ‘reader’ then this reading would take place in a non linear manner. The city has been encountered by many approaches as a written text and the notions of syntax or vocabulary have been projected on its structure. So the question that emerges is how the city as another organically written text and as an information structure could be understood as a language or a text that offers data and linkages. There could be found, thus, a relation between the network of language, the branching system that analyses it, the hypertext that translates this structure into the spatial perception of the cyberspace and finally the city.

It seems necessary the way a city can be understood as text or language to be at least partially analysed. During Modernism, Kevin Lynch, for instance, in his study ‘The image of the city’, published in 1960, investigates how the city is perceived by the individual and how the data it provides are assimilated. His research manipulates the forms of the city and tries to create a syntax. It reminds of Chomsky’s analytical dissemination of the language in inclusive steps. It could be said that Lynch ‘reads the city’ as a language and tries to produce a syntax. He reveals five elements which according to his empirical investigation the pedestrians perceive and translate in their subjective way. These five elements are the paths, the edges, the districts, the nodes and the landmarks [19].

He suggests that the pedestrian produces ‘mental maps’ by translating those configurations. The user, the flaneur, perceives those syntactical elements and wanders in the three dimensional network of the city. Those syntactical elements constitute the systemic and underlying rules that the urban net sets in order to be able to be navigated efficiently in a non linear way. This non linear way of understanding the city is inevitable. The reader has to develop strategies in order to discover in his personal way the hidden network of data that is projected onto the city. Even the definition ‘mental map’ implies the subjectivity of the translation of the surroundings. The notion of the mental map ‘refers to a person’s personal point-of-view perception of their own world’ [20].

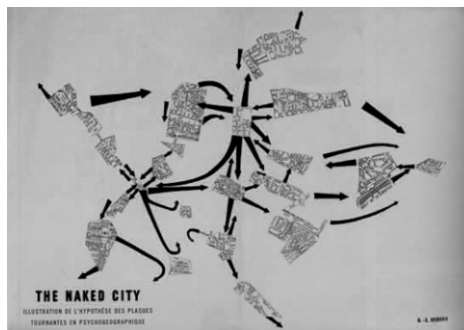

Figure 3. Naked City, Guy Debord

The solid structure of the city and these syntactical configurations which are met in its shapes and form could be paralleled to the text’s underlying skeleton that keeps organized the non linear arrangements of data and potential translations. The user in both ‘texts’, the written and the urban, function as the subjective observers in these constellations of data who metaphorically re-write and re-build them according to their personal intellectual background and the network of data that they carry.

7. Buffer Zone: in between the city and the cyberspace

The city could be imagined as the physical analogue of the cyberspace since the individual while circulating around the urban grid carries his relative network of his knowledge or data with which he interacts with the city. So, if the Situationist ‘derive’ could be paralleled to the real living of the individual and the network of data that he activates within the city, the city map would be distorted or transformed. This transformation would imply a personal mutation of the physical city for every individual that interacts and lives in it. These imaginary transformations could occur if the city was conceived as the physical form of the cyberspace (the ‘Matrix’, the 1999 movie by brothers Wachowski, has already suggested the digital manifestation of the city). Of course, both the real city and the virtual cyberspace guide to a more liquefied version of space since, assuming from the discussed givens, they are both a matrix of data based on a topologically organized skeleton of nodes and linkages that the user organizes. This kind of space is organically developed and gradually formed by the way humans interact with their real and virtual environment. The cross-reading of the reality and the virtual structures by the humans and the projection of data on both spaces opens up a new direction of the space designing and perception.

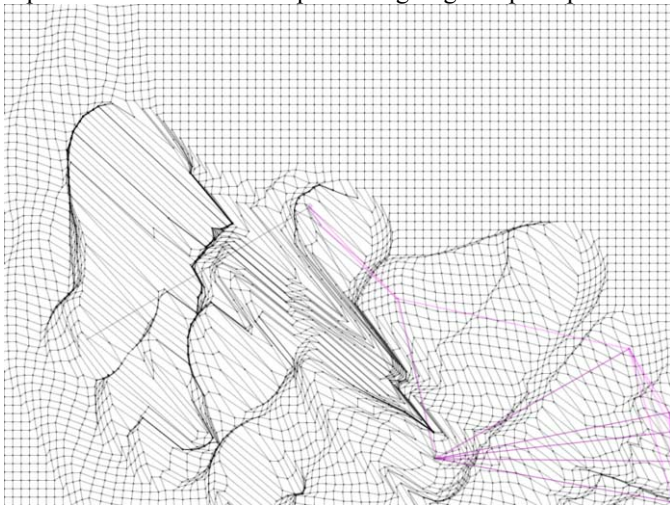

Figure 4. System Mutation, Ioanna Cheinoporou

Regarding to this twofold navigation between the two manifestations of space, the virtual and the real, Ben Cerveny, data visualization designer, speaks of an unprecedented experience for the human, to be able to navigate himself both within the software and real environment. He describes, the city as a platform where the user can act upon and he suggests that it is time for the human rather than using a map, which is just a graphic representation to comprehend the city, to start locating himself within this newly emerged simulation of the city constructed through the continuous flow of data and the visualization techniques and technology [21]. It is fascinating to imagine how the psychogeographical readings that the Situationists had suggested would be reflected on this way of understanding the city that emerges thanks to technological capabilities of the era. Apart from urging the inhabitant to adapt himself on this new medium of reading the city, Ben Cerveny is questioning how the industry of the built environment meets this experience and responds to that. It is obvious, that once again

there is the implication of the flexibility of the city and the need to take advantage of this data flow and accessibility in order to achieve an optimization by urging a shifting of the city condition. In any case, it is an alternative 'reading' of the city which may guide to new territories of designing strategies if we take advantage of the literal and metaphorical re writing of its structure by the inhabitants or users in general.

8. City as a platform

The reading of the real city and of the virtual one could be even more supported by the wide use of the smartphones or the easy-to-carry laptops. So the human is now able to have access on the internet almost wherever he is in the city. The physical urban grid could thus envelop in itself and create a new space in between the real classification of data and the virtual matrix of information in the WWW and manifest this incredibly non linear structure that emerges from this crossbreeding of the two readings in the era that the human lives in an unknown or yet not identified space.

This parallel reading of the digital and physical space could be more emphasized by an existing version of this parallel reading of the physical network of the city and the digital matrix. Applications developed for smart phones suggest a parallel manipulation of physical and digital data. 'Serendipitor' is an application for iPhone that utilizes Google Map's API to "find something by looking for something else." As you navigate your chosen route, the app suggests actions and movements to generate interactive 'flaneries'. In almost the same frame, the 'Derive' is another application that creates unpredictable routes through the use of randomly drawn task cards. Another relevant application is the 'Street Museum' which is launched by the Museum of London. It works by using the geotagging and Google Maps to guide users to several sites in London where, through iPhone screen, various historical images of the city appear and transform the real place into an augmented reality. The American Natural History Museum has also launched an application named ANHM Explorer which not only guides the visitor within the museum by suggesting routes but also it functions as an open library and data provider every time that it recognizes an exhibit.

Furthermore, the city could be imagined as a 'platform' whose materiality is the data. The city as a physical analogue of the cyberspace is transformed into a digital configuration if it is comprehended as a platform where data are constantly added and thus its form starts to be mutated. According to Usman Haque, architect and artist, the society today is the society of the data spectacle. He states that the utilization of data, in terms of urbanity, aims to the optimization of the living conditions, the efficiency of the city structures and the better behavior of the citizens [22]. He suggests that those data can be constantly being produced by the people themselves. A form of interaction emerges. Once again it is the user who controls the data of a given 'text' and rewrites it. This time, the text is the city-platform of interaction and the data are the literal data that the users feed it with and starts writing on it. Those data are uploaded to the cyberspace, on a website which hosts them in real-time. It is obvious that the physical and digital versions of the city are interrelated and the one influences the other implying an unprecedented non linearity in their cross-reference. This non linear networking is now linking not only abstract data between the cyberspace and the city, but real data that the users produce. They could be measurings of the air pollutants or crime data for instance. If the city would change in order to adapt on those data and become more efficient then a new city structure would be revealed and consequently its

psychogeography would be altered; This time not because of the unexpected wandering of the individual but thanks to the individual's contribution, through the cyberspace, to the pursuit of the optimization of the built environment by a real reading that he has undertaken.

9. Conclusion

During this study the notion of the non linearity has been encountered as a systemical network manifested in objects which provide data configurations in order to be perceived. The properties of the "text", as any object that can be comprehended as an arrangement of facts to be read and redefined by the reader has been reflected on wider structures such as the hypertext, the cyberspace and finally the city. At the same time, a sequential deployment and translation of these structures proves that the non linear interconnection of their immaterial material, that is the data, is their common underlying logic.

The city as a 'text' to be read or as the physical analogue of the cyberspace should be encountered as a constantly evolving system of information and not as a static structure. Today, where the technology which allows the parallel navigation of the user in the virtual and the real world at the same time is available and provides numerous visualization techniques, we should perceive the city as a flexible and volatile territory to be translated not only by the user but also by the designer and the built environment industry. The non linear classification of city data should imply the constraints for an algorithmic manipulation of the infinite possibilities that eventually emerge in order this 'text' called 'city' to be read. The imaginary parallel living of the human in the hyperspatial landscape and the real city should imply a new design strategy that will take advantage of this rearrangement of informational particles which build the reality. A bottom-up synthetical direction emerges but under the prism of the design of a rule (algorithm-system) which will organically function and be transformed in itself in order to achieve an equilibrium.

References

- [1] U. Eco, *The Open Work*, trans. Cancogni, A., Harvard University Press, Massachusetts, 1989.
- [2] U. Eco, *The Open Work*, trans. Cancogni, A., Harvard University Press, Massachusetts, 1989.
- [3] U. Eco, *The Open Work*, trans. Cancogni, A., Harvard University Press, Massachusetts, 1989.
- [4] S. Gaggi, *From Text to Hypertext: Decentering the Subject in Fiction, Film, the Visual Arts, and Electronic Media*, University of Pennsylvania, Philadelphia, 1997.
- [5] Y. Lotman, *The Structure of the Artistic Text*, trans. by G. Lenhoff, R. Vroon, Oxon Publishing, Oxford, 1977.
- [6] M. L. Ryan, *Cyberspace, Cybertexts, Cybermaps*, <http://www.dichtung-digital.org/2004/1/Ryan/index.htm>
- [7] D. Hofstadter, *Godel, Escher, Bach: an Eternal Golden Braid. A Metaphorical Fugue On Minds And Machines In The Spirit Of Lewis Carroll*, Penguin Books, London, 1979.
- [8] P. Stockwell (ed.) *Language and Linguistics: The Key Concepts*, 2nd Edition, Routledge, 2007.
- [9] N. Chomsky, *Syntactic Structures*, Mouton de Gruyter, Berlin, 1957.
- [10] T. Berg, *Structure in language: A dynamic perspective*, Routledge, New York, 2009
- [11] M. Gleiser, Borges, *The Universe And The Infinite Library*, NPR: Cosmos & Culture, accessed July 23, 2010, <http://www.npr.org/blogs/13.7/2010/07/23/128716508/the-universe-and-the-infinite-library>
- [12] I. Calvino, *If on a winter's night a traveler*, trans. William Weaver, A Harvest Book, 2004.

- [13] B. Belinda, *Lost In The Archive: Vision, Artefact And Loss In The Evolution of Hypertext* (PhD thesis), University of New South Wales, 2004
- [14] S. Gaggi, *From Text to Hypertext: Decentering the Subject in Fiction, Film, the Visual Arts, and Electronic Media*, University of Pennsylvania, Philadelphia, 1997.
- [15] M. L. Ryan, *Cyberspace, Cybertexts, Cybermaps*, <http://www.dichtung-digital.org/2004/1/Ryan/index.htm>
- [16] L. Manovich, The Poetics of Augmented Space, *Visual Communication* 5 (2006)
- [17] A. J. Elias, *Psychogeography, Détournement, Cyberspace*, http://www.academia.edu/544845/Psychogeography_Detournement_Cyberspace
- [18] M. L. Ryan, *Cyberspace, Cybertexts, Cybermaps*, <http://www.dichtung-digital.org/2004/1/Ryan/index.htm>
- [19] R C. Dalton, S. Bafna, The syntactical image of the city: A reciprocal definition of spatial elements and spatial syntax. In the Proceedings of the *4th International Space Syntax Symposium, London, UK, 2003*
- [20] G. Derek, R. Johnston, and G. Pratt. *Dictionary of Human Geography: Mental maps/Cognitive Maps*, Wiley-Blackwell, Hoboken, 2009
- [21] B. Cerveny, Massively Multiparticipant Adaptive System, presented at the *Smarteometry 2013 Symposium: Constructing for Uncertainty*, The Bartlett, London, April 20, 2013
- [22] Samara Mcilroy, *Urban Drifting*, accessed November 9, 2010, <http://popupcity.net/2010/11/urban-drifting/>
- [23] U. Haque, Constructing data, presented at the *Smarteometry 2013 Symposium: Constructing for Uncertainty*, The Bartlett, London, April 20, 2013

Scripting Cultures, Parametric Urbanism and Adaptive Ecologies

Marianna CHARITONIDOU¹

MSc NTUA Design Space Culture

Abstract. This paper aims to examine how the role of the architect has changed as we shifted to the process of design that Kostas Terzidis calls “Algorithmic Architecture” [1]. The relationships between subjects and objects have changed and thanks to Computer-Assisted Conception and Fabrication (CFAO) systems we are able to manufacture different shapes of each object in the same series. In order to address the problem of global ecological crisis we should investigate how we can create hybrid environments which have characteristics of biological behavior, computational power, behavioral responsiveness, spatial articulation and communication capabilities. I aim to show the potential of the creation of systems that enhance self-organization processes. I encourage the adoption of an approach of responsive architecture based on the combination of material inherent behavior and computational morphogenesis. In order to combine the algorithmic approach to design with the urban planning there is a tendency to map emergent network spaces in real time and to promote urban transformation through the re-coding of urban gaps. In this way the “urban algorithm” is able to operate locally by exploiting constraints and by turning constraints into generative opportunities.

Keywords. simulation, interaction, algorithm, scripting, ecology

Introduction

An issue that is presented in this paper is the interaction between the designer and the scripting environments and the emergence of a different type of relationship between subject and object because of the use of Computer-Assisted Conception and Fabrication (CFAO) systems. The interaction between philosophy and simulation referring to the work of Manuel DeLanda, the interpretation of the work of Gilles Deleuze by John Rajchman, the use of genetic algorithms in architecture, the transferral of information into the production of a spatial and material organization, the simulation of evolution using genetic algorithms, the investigation of mapping patterns of information, the relationships between network science and information visualization are some of the issues that I aim to address in this paper. An important issue that we need to address is the problem of global ecological crisis. In order to address this problem we should investigate how we can create hybrid environments which have characteristics of biological behavior, computational power, behavioral responsiveness, spatial articulation and communication capabilities.

¹ Corresponding author: charitonidou@aaschool.ac.uk

1. Interaction Between the Designer and the Computer Integrated Design

Bernard Cache in the chapter of his book “Earth Moves: The Furnishing of Territories” entitled “Subjectile/Objectile” aims to examine the ways that Computer-Assisted Conception and Fabrication (CFAO) systems have transformed and continue to transform the ways of perception of the relationships between subjects and objects [2]. Cache emphasizes the importance of the fact that the second-generation systems lay the foundation for a nonstandard mode of production [2,3]. He focuses on the fact that the modification of calculation parameters allows the manufacture of a different shape of each object in the same series. The importance of the above statements is based on the fact that unique objects can be produced industrially.

Cache uses the term “subjectiles” to call variable objects created from surfaces and the term “objectiles” to call variable objects created from volumes. He is interested in investigating the question of what is an object. In order to investigate this question he tries to analyze the ways in which industry conceives and fabricates some set of things that we buy because they create use effects. According to Bernard Cache some of the factors that influence each stage in the life of a product are the following: consumption, production, representation, modeling, function and marketing. The use of parametric functions and the use of nonstandard mode of production allow the design of objects that are no longer subordinated to mechanical geometry.

Another relationship that seems to be extremely dominant in the discussion that concern the interaction between computation and architecture is the relationship between the designer and the simulation [4]. The relationship between the designer and the chosen computational design tools and the influence of these tools on the architectural design process is important in an era that the center of attention is shifted from the representation of form to the simulation of space. This relationship is connected to the discussion that concerns the way in which the designer is able or not able to control the result of the process. The investigation of the ways of interaction between the designer and the scripting environments aims to show that another relationship between subject and object has emerged from the moment that the parametric design and the algorithmic architecture has emerged.

Generative methods are procedures that have a liberating design force and can be related to the procedural aspects of the real design. Generative methods are processes that cannot be captured by static drawing. They are based more on procedure than geometric form. In many cases of generative design construction logic is considered with some rigor early on in the process. Manual and automated fabrication depend on tool paths that can be encoded directly in the generating script. The use of genetic algorithms, cellular automata, parametric procedures and other computer-based systems provide the opportunity to shift from an approach based on the representation of form to an approach based on the simulation of space. Digital fabrication in architecture is a recent phenomenon that emerged during the last 15 years. This process has facilitated a greater fluidity between design generation, development, and fabrication than in traditional approaches. The designer can engage with the entire process from concept to final product. A main characteristic of code-based systems is the use of mathematical systems. The script itself does not produce architecture but produces possibilities. Drawing and CAD are modes of representation. Scripting, on the other hand, is based on logical loops and cause-effect relationships and it is not so much a mode of representation as it is a mode of generation.

2. Genetic Algorithms and Virtual Space

In the essay “Philosophy and Simulation: The Emergence of Synthetic Reason” Manuel Delanda analyzes different genres of simulation from cellular automata and genetic algorithms to neural nets and multi-agent systems. He claims that these genres of simulation can be used as a means to conceptualize the possibility spaces associated with causal and other capacities [4]. Manuel DeLanda in “Intensive Science and Virtual Philosophy” focuses on the intersection of philosophy and science and he explains how Deleuze's system of thought is fundamental to a proper understanding of contemporary science that is based on self-organization, non-linear dynamics and complexity theory [5]. The shift from the representation of form to the simulation of space is related to the use of genetic algorithms that aims to simulate the space of all possible automata. The use of genetic algorithms aims to connect the space of possible rules to the space of possible ways of tiling a space. Genetic algorithms are based on the relation between genotype and phenotype [4,5].

Manuel DeLanda in “Deleuze and the use of the Genetic Algorithm in Architecture” refers to Deleuze's terms “abstract diagram” and “virtual multiplicity” and he underlines that Deleuze uses these two terms to refer to entities like the vertebrate body plan [6]. Sanford Kwinter claims that “soft systems evolve by internal regulating mechanisms, yet always in collaboration with forces and effects – that is, information – arriving from an outside source” [7]. According to Brian Massumi “form follows the design process”. It is interesting to think of this slogan in comparison to the slogan “form follows function” of modern movement. According to Brian Massumi architects are no longer just representing forms taken from a preexisting repertory as in postmodernist architecture. The role of the architect is shifted to setting things up so that new forms can evolve. We are confronted with a case in which architects aim to integrate new technologies into their buildings in such a way that their role becomes the design of possibilities of experience. Their role is not limited to trying to build for practical function. Abstract spaces must be actively designed to integrate a measure of indeterminacy. As a consequence, the space of abstraction itself becomes active. Brian Massumi in “Sensing The Virtual, Building The Inesible” supports that “topology deals with continuity of transformation” and “engulfs forms in their own variation”. According to Brian Massumi “approached topologically, the architect's raw material is no longer form but deformation” [8]. Form emerges from the process. Texts, information, images, and sounds are now all the object of numerical manipulation.

One of the aspects that this workshop aims to examine is the way that the viewer perceives digitally enhanced environments. John Rajchman in his book “The Deleuze Connections” refers to Deleuze's question about how information and interaction are “framed” so as to allow for common sense. Deleuze is concerned about this question in his study for cinema, twenty years after “Difference and Repetition” [9,10,11]. Rajchman claims that Deleuze “rejected the computer model of the mind”. According to Rajchman “when form is no longer determined by a prior field or ground given to an independent or overseeing eye, it starts operate in other, less systematic or predictable ways” [9].

Brian Massumi in “Sensing The Virtual, Building The Inesible” notes that “one thing swept away is the popular image of the architect as autonomous creative agent drawing forms from an abstract space of Platonic preexistence to which he or she has inspired access” [8]. He also claims that “the architect must follow the same process that the form follows” and that “the architect's job is in a sense catalytic, no longer

orchestrating” [8]. As far as I am concerned I find interesting the following remark of Brian Massumi: “The design process takes on a certain autonomy, a life of its own” [8].

Manuel DeLanda in “Matter Matters” notes that evolvable materials have the capacity to profit from randomness. He supports that architects and urban planners should focus on using this quality of evolvable materials and he claims that they should try to simulate evolution in computers breeding new designs using Genetic Algorithms [12]. If we conceive matter and form placed in a dynamic rather than a fixed relationship we could refer to a morphogenetic model of urban design. Generative algorithms dissolve the opposition between mathematics and biology and between abstract models and concrete forms.

3. Future Cities and Mapping Patterns of Information

John Rajchman in his book “Constructions” refers to “Future Cities” and he chooses to use this name for the seventh chapter of the book. He begins this chapter questioning about what is the problem of “future cities” or “cities of the future”. He is also interested in the investigation of the role that the architecture or architectural intervention might play in such future cities. He underlines that today there are two problems that should be perceived related the one to each other. According to Rajchman these two problems are the following:

- how to get away from certain utopian or transgressive images of thought - or the “future” of thought - and envisage other modes of critical intervention and critical analysis;
- how to develop a new conception or image of cities, their shapes, their distinctive problems, the ways in which they figure in our being and being-together, the manner in which they acquire their identities, the kinds of movement they introduce within and among us [13].

The focus should shift to the emergence of a model of architectural discourse that is based on the simulation of the evolution. The main idea is that through the deployment of patterns we can advance a new relationship between architecture and nature. The designers should focus to the simultaneous production of architectural objects and the environment surrounding them. The contemporary advanced spatial practices and CAD/CAM are now pushing patterns to encompass a greater range of structural, programmatic, aesthetic and material effects and properties.

Another issue that seems to emerge is the issue of mapping patterns of information. Manuel Lima in the book “Visual Complexity: Mapping Patterns of Information” aims to provide a comprehensive view of the visual representation of networks through the depiction of networks from a practical and functional perspective. Researchers, scientists and designer across the globe portray an increasing number of network structures in innovative ways. Manuel Lima’s focus is to analyze the visualization of these networks. Lima in this book examines the relationships between network science and information visualization [14].

4. Scripting Cultures and Parametric Urbanism

Increasing importance has been given to the role of parametric design and recent developments in algorithmic design processes have opened the way to scripting that

allow complex forms to be grown from simple iterative methods while preserving specified qualities. Mark Burry in “Scripting Cultures: Architectural Design and Programming” investigates the cultural implications of scripting and the computer engagement in practice. He claims that “scripting affords a significantly deeper engagement between the computer and the user by automating routine aspects and repetitive activities thus facilitating a far greater range of potential outcomes for the same investment in time”. Burry in this book enquires into the cultural implications of scripting and asks what are the cultures of scripting as, emerging in myriad ways, they more conspicuously influence the designer’s toolkit [15]. Algorithms have become the objects of a new programming culture.

Nowadays, there is a tendency to focus on the edge of a rapidly expanding city, where the instruments of urbanization are directly applied to the raw landscape. This tendency could be explained by the fact that architects and urbanists try to reframe the study of cities and to understand the economic, social, environmental and political forces that influence urban growth and development. Parametric urbanism is a term used to express the method, the strategy of designing “city systems of infrastructural connections that are not simply preadapted to the environment, but are programmed to construct actual relations between already existing entities” [15]. According to Luciana Parisi “parametric urbanism includes rules for selecting, contrasting, and adopting data from previous sets in the computation of present and future quantities of relations” [16]. Luciana Parisi supports that algorithmic computation is not simply an abstract mathematical tool but constitutes a mode of thought in its own right. She claims that its operation extends into forms of abstraction that lie beyond direct human cognition and control.

The re-conceptualization of architectural function in terms of action-artifact networks and the shift from drawing to scripting contributes to the idea that architecture is not an autonomous discipline. The parametric approach of architecture is related to the realization that an interdisciplinary approach is necessary. Manuel DeLanda in “Philosophy and Simulation: The Emergence of Synthetic Reason” notes that “simulations are partly responsible for the restoration of the legitimacy of the concept of emergence because they can stage interactions between virtual entities from which properties, tendencies, and capacities actually emerge” [4]. He also supports that philosophy could be used in order to synthesize into an emergent materialist world view the powers of matter and energy.

In order to combine the algorithmic approach to design with the urban planning there is a tendency to map emergent network spaces in real time and to promote urban transformation through the re-coding of urban gaps. In this way the “urban algorithm” is able to operate locally by exploiting constraints and by turning constraints into generative opportunities. This kind of operation could contribute to the model of a self-organizing city. The idea that is hidden behind an approach to urban design like this is that the city is never complete or finished. The city is conceived algorithmically as a continuum. Marco Polleto in “Systemic Architecture: Operating Manual for the Self-Organizing City” defines urban space as “the product of processes of co-evolution of multiple agents behaving as a coherent assemblage” [17]. Two of the main issues that Marco Polleto and Claudia Pasquero try to address in this book are the ecology of the self-organizing city and the issue of urban algorithms. The algorithm is characterized by the fact that it is based on the acceptance that the relationship between input and output may not be deterministic or linear and may involve chance.

As far as the urban and architectural context for interaction is concerned there is a tendency to understand buildings as urban interactive artifacts. According to this tendency the role of the architect and the role of the urban designer is to design responsive environments. As far as the interactions of the digital and physical are concerned I would like to underline that the digitization of the design process is related to the incorporation of digital into physical. The potential for applying digital simulation for research in urban planning and development is promising. There is a shift from the use of standard drafting packages to the more experimental use of generative design tools and parametric modeling. The use of generative design tools, parametric modeling and digital technologies have come to play a major role in architectural production. In "Digital Cities" the main theme that the authors aim to address is how generative design tools, parametric modeling and digital technologies help architects to operate at the urban scale [18]. The importance of the use of "urban algorithms" is based on the fact that they are not conceived as complete and finished systems. This means that using "urban algorithms" the design, construction and evolution of a city are conceived as a continuum.

5. Self-organizing City and Performance-based Systems

The concept of the self-organizing city is based on the idea that the bottom-up mechanisms are the core of the way that the cities develop. An important issue that we need to address is the problem of global ecological crisis. In order to address this problem we should investigate how we can create hybrid environments which have characteristics of biological behavior, computational power, behavioral responsiveness, spatial articulation and communication capabilities. This is not far from the idea of performance-based design. The challenge is to design performance-based systems that are informed and tested through scenario based on performance simulations. Adaptive ecologies and homeostatic urbanism are based on the analysis of urban development through an adaptive model of ecology. I could refer to the concept of urban growth simulation. Another aspect that shows the challenges of generative approaches to architectural design and self-organizing computation is the emergence of the possibilities that offer the pattern generation tools.

Nikos Salingaros in "Principles of Urban Structure (Design/science/planning)" explains how cities actually work. In this book he underlines that there is an increasing awareness that a city needs to be understood as a complex interacting system [19]. There is a challenge to map complex interacting systems of the city. Manuel Lima in the forward of "Visual Complexity: Mapping Patterns of Information" notes that visualizations of complex data can make statements and ask "questions about the world by selecting parts in particular ways" [14]. We could use computing and programming in order to incorporate biophysical contingencies and situations that users, participants or environmental factors can make available to programming by adding more variables to intelligent network devices.

In order to examine some of the ways users develop bottom-up systems in order to analyze and investigate the contemporary adaptable city, I could refer to the potential for applying digital simulation for research in urban planning and development. The

designers, the urban planners and, in general, the people involved in the decisions that influence the formation and evolution of cities should adopt a strategy of environmental tinkering versus one of accommodation or balance with an external natural world. Associative design systems can control local dynamic information and should be used in order to reassess and propose alternatives to conventional urban masterplanning. I suggest the use of a parametric approach to urbanism that investigates how associative design systems can control local dynamic information flows through interactive systems, spaces and interfaces. The use of multi-agent simulations provides the opportunity to model a given phenomenon. Before we generate buildings using digital simulations of urban growth we should model the decision-making processes that give rise to them. Models of agent-based behavior can be developed in order to understand the decision-making processes within an actual city. The advantage of bottom-up emergent systems where individual agents respond to one another is that they offer behavioral translations of topology that can have radically varied outputs.

6. Examples of Applications

I could refer to "MIT Senseable City Laboratory" which investigates the emergent possibilities of the increasing deployment of sensors and hand-held electronics in the study of the built environment. I would like to present four examples of applications based on the use of the emergent possibilities of Computer-Assisted Conception and Fabrication (CFAO) systems. The "iSPOTS" project was, also, developed in the "MIT Senseable City Laboratory". The iSPOTS project aims at describing changes in living and working at MIT by mapping the dynamics of the wireless network in real-time. Thus, the complex and dispersed individual movement patterns that make up the daily life of the campus can be revealed, helping TO answer many questions: Which physical spaces are preferred for work in the MIT community? How could future physical planning of the campus suit the community's changing needs? Which location-based services would be most helpful for students and academics? Also, as many cities around the world are launching extensive wireless initiatives, the analysis of the MIT environment could provide valuable insights for the future. The "iSPOTS" project is illustrated in Figure 1.

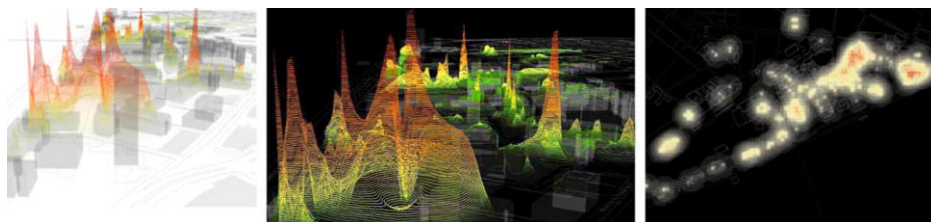

Figure 1. "iSPOTS" project show how wireless Internet is used on the MIT campus in real-time. Log files indicating the number of users connected to each WiFi access point are collected at 15-minute intervals and then interpolated as a color field, providing a visual comparison between different areas of the campus. Red indicates a large number of users per access point. (<http://senseable.mit.edu/ispots/>)

The "WikiCity" project, which was developed in the "MIT Senseable City Laboratory", investigates the scenario of how can a city perform as an open-source real-time system. Events that were occurring around the city are indicated at the corresponding location on the map at the time they occurred. The four key components of a real time control system are entity to be controlled in an environment characterized by uncertainty, sensors able to acquire information about the entity's state in real-time, intelligence capable of evaluating system performance against desired outcomes, physical actuators able to act upon the system to realize the control strategy. The "WikiCity" project is illustrated in Figure 2. The "Serendipitor" project was developed at V2_ Institute for the Unstable Media as part of a joint artist residency with Eyebeam Art and Technology Center. It is part of the Sentient City Survival Kit, a project of Creative Capital. You enter an origin and a destination, and the app maps a route between the two. As you navigate your route, suggestions for possible actions to take at a given location appear within step-by-step directions designed to increase the likelihood that, in the end, you will have encounters you could never have pre-planned. You can take photos along the way and, upon reaching your destination, send an email sharing with friends your route and the steps you took. The "Serendipitor" project is illustrated in Figure 2.

The "HygroScope - Meteorosensitive Morphology" project was developed by the Institute for Computational Design in the University of Stuttgart in the department of Transsolar Climate Engineering. It was developed by Achim Menges in collaboration with Steffen Reichert. It explores a novel mode of responsive architecture based on the combination of material inherent behavior and computational morphogenesis. The dimensional instability of wood in relation to moisture content is employed to construct a climate responsive architectural morphology. Suspended within a humidity controlled glass case the model opens and closes in response to climate changes with no need for any technical equipment or energy. Mere fluctuations in relative humidity trigger the silent movement. The material structure itself is the machine. This project is illustrated in Figure 3.



Figure 2. "Real Time Rome" project and "Serendipitor" project. "Real Time Rome" project uses six different visual software to present real-time information about Rome. "Real-Time Rome" combines different datasets in a single interface: real-time data, GIS data and raster images. In "Serendipitor" you can enter an origin and a destination, and the app maps a route between the two. You can increase or decrease the complexity of this route, depending how much time you have to play with. As you navigate your route, suggestions for possible actions to take at a given location appear within step-by-step directions designed to increase the likelihood that, in the end, you will have encounters you could never have pre-planned.

(<http://senseable.mit.edu/realtimerome/images/gis.jpg> and
<https://itunes.apple.com/us/app/serendipitor/id382597390?mt=8>)



Figure 3. “HygroScope - Meteorosensitive Morphology” project, by Achim Menges & Steffen Reichert, Institute for Computational Design, University of Stuttgart, Transsolar Climate Engineering. (<http://icd.uni-stuttgart.de/?p=7291>)

7. Conclusion

What is the place of the public in the form of parametric urbanism, and how this approach towards design can address the notion of common and collective spaces are two issues that should not be ignored. Another important issue is how to take into consideration the relationships between architecture and nature when we adopt an algorithmic approach towards architectural design and urbanism. As far as I am concerned I think that in order to create adaptive ecologies we should investigate the possibilities that an approach of homeostatic urbanism offers. In order to do that, we should try to construct actual relations between already existing entities in the cities. In addition, we should adopt an approach of responsive architecture based on the combination of material inherent behavior and computational morphogenesis. We should also elaborate on the concept of the self-organizing city which is based on the idea that the bottom-up mechanisms are the core of the way that the cities develop. Finally, we should develop mechanisms and processes in order to analyze the urban development through an adaptive model of ecology. This approach could be combined to the simulation of evolution of different parameters in using genetic algorithms. In this way, we could also investigate not only the evolution of different parameters but their interactions as well.

References

- [1] K. Terzidis, *Algorithmic Architecture*, London, New York: Routledge, 2006.
- [2] B. Cache, *Earth Moves: The Furnishing Territories*, translated by Anne Boyman. Edited by Michael Speaks, Cambridge, Massachusetts: The MIT Press, 1995.
- [3] P. Beaucé and B. Cache, “Towards a Non-Standard Mode of Production,” in *Phylogenesis: foa’s ark foreign office architects*, Barcelona, New York: Actar, 2004, p. 390 – 407.
- [4] M. DeLanda, *Philosophy and Simulation: The Emergence of Synthetic Reason*, London, New York: Continuum International Publishing Group, 2011.
- [5] M. DeLanda, *Intensive Science and Virtual Philosophy*, London, New York: Continuum, 2002.
- [6] M. DeLanda, “Deleuze and the Use of Genetic Algorithm in Architecture”, in *Designing for a Digital World*, N. Leach, Ed. London: Wiley-Academy, 2002.

- [7] S. Kwinter in *Culture Lab 1*, B.Boigon, Eds. New York: Princeton Architectural Press, 1996.
- [8] B. Massumi, "Sensing the Virtual, Building the Inesible", in *Hypersurface Architecture*, S. Perrella, Eds. *Architectural Design* (Profile no. 133), **68** (5/6), May-June 1998, 18.
- [9] J. Rajchman, *Deleuze Connections*, Cambridge, Massachusetts: MIT Press, 2000.
- [10] G. Deleuze, *Difference and Repetition*, translated by P. Patton, London, New York: Continuum, 2004 (1968).
- [11] G. Deleuze, *Cinema 1: The Movement-Image*, Trans. Hugh Tomlinson and Barbara Habberjam. Minneapolis: University of Minnesota Press, 1986.
- [12] M. DeLanda, column #5 "Evolvable Materials," in *Matter Matters*, a series from Domus Magazine from n. 884 to 901 between 2005 and 2007.
- [13] J. Rajchman, *Constructions*, forward by P. Virilio, Cambridge, Massachusetts: MIT Press, 1998.
- [14] M. Lima, *Visual Complexity: Mapping Patterns of Information*, New York: Princeton Architectural Press, 2011.
- [15] M. Burry, *Scripting Cultures: Architectural Design and Programming* (Architectural Design Primer), London: John Wiley & Sons, 2011.
- [16] L. Parisi, *Contagious Architecture: Computation, Aesthetics and Space*, Cambridge, Massachusetts: The MIT Press, 2013.
- [17] M. Polleto and C. Pasquero, *Systemic Architecture: Operating Manual for the Self-Organizing City*, London, New York: Routledge, 2012, p. 14.
- [18] N. Leach, "The Limits of Urban Simulation: An Interview with Manuel DeLanda," in *Digital Cities, Architectural Design*, Volume 79, Issue 4, July/August 2009, London: John Wiley and Sons, pp. 50–55.
- [19] N. Salingaros, *Principles of Urban Structure (Design/science/planning)*, Amsterdam: Tecne Press, 2005.

Subject Index

3D virtual worlds	443	cloud storage	232
abstract argumentation	368	cloud-based 3D repositories	246
accelerometer	403	cloud-of-things	238, 252, 262
ACM-IEEE curricula	454	co-creation	604
activities of daily working	393	coding	579
activity recognition	393	cognitive impairment	116
adaptation	24, 57, 541	collaboration	110
adaptive course sequencing	466	collaborative R&D	190
adaptive educational hypermedia		collective	647
system	466	collective design	744
affective agents	347	collective intelligence	238
affective computing	97, 128	communications	318
affective decision making	347	community capacity	653
agent-based model	386	community informatics	653
agent-based modeling	507	community memory	653
algorithm	773	competency based education	419
Alzheimer	116	complex event processing	12
ambient assisted living	78, 403	complex hierarchy	744
ambient intelligence	172, 338, 377	complexity	24
ami	57	components	57
archaeological museums	541	compressive sensing	4
argumentation	368	computational thinking	579
arrhythmia	36	computer assisted therapy	116
artificial intelligence	443	computer science curriculum	454
assemblage	571	computerized adaptive tests	419
association rules	69	connectivity	709
augmented reality	252, 274, 519	constructionism	190
augmented spaces	555	content metadata	232
automation	330	context-awareness	57
avant-garde	571	context-based information	386
bionic lens	274	cooperative modeling	141
blended learning	443	craft	598
blended reality	190	crafting	579
bots	443	creativity	588
bottom-up culture	604	critical design	722
building management system	393	cross-platform integration and	
business innovation	274	coopetition	201
buzz-boards	252, 454	crowd intelligence	238
cinema	700	crowd simulation	507
city	700	cultural citizenship	653
classifiers	36	cultural heritage	530
cloud computing	238, 274	cyberspace	761
cloud of things (COT)	262	cyborg	709

cyclic instability	222	fabrication	598
data	571	feature reduction	36
data flow	172	fragment	571
data mining	69	future internet	732
decision making	368	fuzziness	732
delocalization	709	game-like urban activities	160
design democratization	604	genetic algorithms	222
design studio	588	GPS	647
design theory	722	graph analysis	90
DfE national curriculum for computing	454	ground-truth data set	128
differential evolution	36, 222	hacker-space	306
digital	598	healthcare	403
digital cities	752	home	330
digital commons	579	home for the aged	262
digital footprint	752	homecare	403
digital interactive storytelling	541	human-centered computing	431
digital memories	653	human-computer interaction (HCI)	262, 356, 722
digital natives	562	human-machine interface (HMI)	190, 284
digital nomad	709	hybrid spaces	684
directional audio	478	immersive environment	274
discrete wavelet transform	4, 97	immersive presence	478
distributed environments	318	immersive reality	478
distributed infrastructures	150	implants	284
DIY	214	information systems	431
do-it-yourself (DIY) approach	262	information technology	700
dual reality	190	informational self-determination	172
dynamic capability	201	intelligent environment (IE)	12, 238, 262, 294, 368, 454
early warning	377	intelligent office	393
ECG	36	intelligent recommendations	507
ecology	773	intelligent tutoring system	419, 466
educational technology	454	intelligent user	700
e-learning	443	interaction	773
electracy	571	interaction design	722
embedded computing	238, 454	interactive urban communication	141
embodied conversational agents	431	interdisciplinarity	24
emergency event reporting and information dissemination	678	interdisciplinary design	579
emotions	97, 128	internet-connected	201
empowerment	653	internet-of-things	190, 214, 238, 252, 454, 635
end-user	150	interreality	190
entbergen	571	iPromotion	246
environmental applications	377	iWorlds	294
environmental sensing	160	KNN	36
evaluation	493	knowledge management	732
event-driven architecture	12	learning activity	252
event-driven model	393	learning by doing	562
evolutionary algorithms	294		
experiment	647		

learning in digital community	562	platform dominance	201
liveability	629	play and learning	588
location based services	160, 678	poiesis	571
long-term data monitoring	78	polycentrism	629
maker-space	306	preference	647
map	647	presence	493
M-commerce	47	preservation of digital content	232
mimicry	294	privacy	172
mixed reality	190, 252	private space	172
mobile applications	318	product innovation	306
mobile augmented reality	252	programming and developing interfaces	356
mobile computing	673	provenance	284
mobile device geolocation	678	proxemic interaction	617
mobile interaction	617	PSO	36
mobile learning	419	psychogeography	761
mobile sensors	403	psychology	443
mobile sound art	684	public screen	617
mobile tour guides	431	public space	172
mobility	709	publish-subscribe	12
MR directional audio	478	quality of experience	507
multi-agent systems	368	question-answering systems	530
multi-agents framework	347	questionnaire	635
multimedia storage	232	random walk	47
multi-modal sensors	12	Raspberry Pi	214
multi-objective genetic algorithms	69	real time computation	178
multi-performativity	24	real time control systems	178
multisensory integration	284	recommender systems	47
Naive Bayes	36	remote rendering	246
narrative	700	robotics	454
natural language processing	530	'rubber hand illusion'	284
neo-nomad	709	science fiction prototype (SFP)	262, 274
network	709, 744	science-fiction	306
neuroengineering	284	scripting	773
nomadic agents	222	search	635
non linearity	761	second life	443
NPC behaviour	294	security	284
older people support	78	self-directed learning environment	562
outdoor spaces	377	semantic analysis	90
panoramic audio	478	sensing space	178
participatory design	579	sensor	284, 330, 635
pedestrian	647	serious games	519
personalization	541	shape grammars	588
personalized interactive services	78	shortest path	647
pervasive computing	110	simulation	386, 773
pervasive sensing	393	smart	330
phenomenology of space	722	smart alarm clock	214
physiological	97		
physiological data	128		
piezoelectric technology	150		

smart application	386	text	761
smart city	160, 617, 629, 635, 673, 732	text mining	90
smart home	338	third industrial revolution	604
smart objects	214, 555	thresholding	4
smart workplace	338	total immersion	274
smart-phones	454	tourism	386, 663
SOA	57	ubiquitous computing	722
sociable smart city	673	ubiquitous maps	663
social	330	urban computing	684
social context	663	urban informatics	673
social design intelligence	604	urban planning	752
social graph	90	urbanism	761
social imprimers	604	user modeling	732
social interaction	555	video gaming	274
social matching	110	virtual hackerspace	190
social networks	90	virtual laboratory	190
soundwalk	684	virtual museum	493
sparsity reduction	4	virtual-appliances	306
speculative design	722	visiting styles	507
surveillance	172	visitor flow	386
survey	635	visualization platform	178
sustainability	629	VR advertising	246
system on a chip	214	wavelet packet transform	4
tacit knowledge	579	Web 3D	246
tangible and embedded interaction	555	wide area sensor networks	377
tangible user interface (TUI)	190	wireless locationing	178
teaching learning innovation	443	work-home integration	338
technology	700	XBEE	214
telepresence	478	xReality objects	190
		young people	519

Author Index

Abdullah, A.	47	Cech, P.	317
Adamopoulos, G.	579	Cesta, A.	78
Aguiar, R.	110	Chalon, R.	617
Aguiñaga, A.R.	97	Charitonidou, M.	773
Alanís-Garza, A.	36, 97	Charitos, D.	v, 160, 684, 722
Alhaddad, M.J.	190	Cheinoporou, I.	761
Ali, S.	128	Chin, J.	187, 214, 238
Almeida, A.	318	Chorianopoulos, K.	647
Alrashidi, M.	252	Christopoulou, E.	615, 673
Alzahrani, A.	466	Cimler, R.	338, 386
Ampanavos, S.	172	Claude, X.	507
Anacleto, R.	318	Cook, D.J.	3
Anagnostopoulos, V.	232	Coraci, L.	78
Ananta, I.	238	Correa, P.	178
Antoniou, A.	507	Cortellessa, G.	78
Antonopoulou, E.	561	Cuesta-Frau, D.	36
Antunes, M.	110	Dafoulas, G.	443
Argyriou, V.	356	Daryanti, S.	238
Armeni, I.	647	David, B.	617
Augusto, J.C.	3, 417	Davies, M.	294
Avenoğlu, B.	12	De Benedictis, R.	78
Avouris, N.	491	de Kreek, M.	653
Avrami, E.	722	Di Loreto, I.	519
Aztiria, A.	3	Diamantaki, K.	160
Bacharidou, M.	579	Didimo, W.	629
Badaracco, M.	419	Divitini, M.	519
Bala, I.	752	Doctor, F.	109, 116
Ball, M.	238	Doulamis, A.	232, 246
Baltazar, R.	97, 116, 222	Doumanis, I.	431, 530
Baltazar-Flores, R.	36	Efthymiou, S.	744
Barrie, P.	663	Eleftheratou, S.	541
Barroso, J.	347	Elliott, J.B.	252
Bechara, K.	678	Eren, P.E.	12
Behan, M.	330	Fanou, P.G.	699, 700
Bermúdez, L.	116	Farshchian, B.A.	90
Bernal, G.	598	Figueiredo, L.	318
Besharat, J.	663	Freitas, C.F.	347
Binucci, C.	629	Gardner, M.	190, 238, 252, 466
Botía, J.A.	v	Garofalakis, J.	615
Bounia, A.	491	Garrido, J.L.	57
Callaghan, V.	187, 190, 222, 238, 252, 294, 306, 417, 454, 466, 478	Gavra, H.	141
Caridakis, G.	732	Gomes, D.	110
		Gourdoukis, C.	744

Gutiérrez, B.	116	Martinez, L.	419
Hagras, H.	478	Mathisen, B.M.	90
Ham, D.	588	Mavrommati, I.	695
Hatzopoulos, D.M.	699	McGovern, J.	90
Herrera-Acuña, R.A.	356	Merreiros, G.	368
Holland, A.	150	Mezura, E.	222
Houghton, R.	128	Mietz, R.	635
Huang, Y.	274	Mikulecky, P.	317, 377
Ioannidis, Y.	541	Mitakou, E.N.	699, 700
Istiyanto, J.E.	238	Mls, K.	338
Jin, H.	617	Mohamadian, H.	4
Johal, J.	128	Montecchiani, F.	629
Kaimakamis, N.	160	Moratori, P.	128
Kapetanakis, K.	246	Moschouti, E.	752
Karakiewicz, J.	150	Moulos, V.	246
Karvounis, M.	541	Mylonas, P.	732
Kasimati, E.	24	Naudet, Y.	507
Katifori, A.	541	Navarro, J.	116
Kay, İ.	562	Noguera, M.	57
Kaya, B.	69	Novais, P.	318
Killintzis, V.	493	Ojala, T.	693
Kofod-Petersen, A.	90	Olševičová, K.	386
Kollias, S.	732	Oosterbroek, M.	653
Komninos, A.	663	Orlandini, A.	78
Kontakis, K.	246	Özkar, M.	562
Kovalchuk, Y.	284	Padilla-Navarro, C.	36
Krejcar, O.	330	Paliokas, I.	493
Kymäläinen, T.	262	Palumbo, F.	78
Kyriakidi, M.	541	Panagoulia, E.	24
Lambrinos, L.	678	Papadopoulou, A.	561
Langensiepen, C.	393	Papanikolaou, D.	139
Lear, M.	454	Papoulias, G.	172
Lepouras, G.	507	Patias, P.	493
Li, X.	47	Peña-Rios, A.	190, 454
Liarokapis, F.	493	Petrelli, D.	555
Lima, C.	110	Philippou, M.	709
Lino, C.	116	Pujol, L.	541
Liotta, G.	629	Puteh, S.	393
Liu, J.	419	Ramos, C.	317, 347
Lopes, N.	368	Ringas, D.	615, 673
López Ramírez, M.	97	Rizopoulos, C.	160
Lotfi, A.	393	Rodríguez, M.J.	57
Luz, N.	318	Rodríguez-Domínguez, C.	57
Lykourantzou, I.	507	Römer, K.	635
Malamos, A.G.	246	Romo, A.	178
Mander, M.	519	Roussou, M.	491, 541
Mania, K.	493	Ruiz-López, T.	57
Marreiros, G.	347	Saleeb, N.	443
Martínez, C.	116	Santos, R.	347, 368

Sardis, E.	232, 246	Vafiadis, G.	246
Sartore, M.	629	Vanz, E.	150
Scott, G.	214	Vardouli, R.	571
Shipp, V.	128	Vardouli, T.	561
Siolas, G.	732	Varvarigou, T.	232
Smith, S.	431, 530	Vasilakis, C.	507
Sosa, A.	222	Vayanou, M.	541
Stafylopatis, A.-G.	732	Velastin, S.A.	356
Stimec, A.	78	Vilarinho, T.	90
Suba, P.	403	Vouliouri, E.	561
Sylaiou, S.	493	Wagner, C.	128
Talianni, K.	684	Wang, M.	417
Theona, I.	160	Welch, P.	128
Tobias, E.	507	Wu, H.-Y.	201, 274
Torrejon, A.	478	Yamada, J.	178
Torres, J.	116	Ye, Z.	4
Trimailovas, I.	519	Yiannoutsou, N.	491
Tsetsos, V.	160	Zamani, E.D.	699, 700
Tucnik, P.	403	Zampoglou, M.	246
Tung, C.-M.	201	Zamudio, V.	97, 109, 116, 222, 454
Turgeman, Y.	604	Zamudio-Rodríguez, V.	36
Türkoğlu, İ.	69	Zheng, P.	454

This page intentionally left blank

This page intentionally left blank

This page intentionally left blank